

5 A, 1200 V, low drop internally clamped IGBT

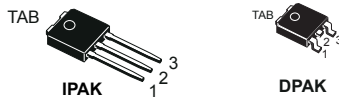

Features

- Low on-voltage drop ($V_{CE(sat)}$)
- High current capability
- Off losses include tail current
- High voltage clamping

Applications

- Switching applications

Description

These devices are low drop internally clamped IGBTs developed using advanced PowerMESH™ technology. This process guarantees an excellent trade-off between switching performance and low on-state behavior.

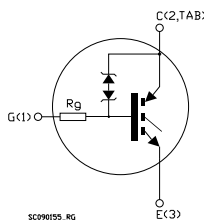

Product status link

[STGD5NB120SZ](#)

1 Electrical ratings

Table 1. Absolute maximum ratings

Symbol	Parameter	Value	Unit
V_{CES}	Collector-emitter voltage ($V_{GE} = 0\text{ V}$)	1200	V
I_C	Continuous collector current at $T_C = 25\text{ °C}$	10	A
	Continuous collector current at $T_C = 100\text{ °C}$	5	
$I_{CP}^{(1)}$	Pulsed collector current	10	A
$I_{CL}^{(2)}$	Turn-off latching current	10	A
V_{GE}	Gate-emitter voltage	± 20	V
V_{ECR}	Emitter-collector voltage	20	V
$E_{AS}^{(3)}$	Single pulse avalanche energy at $T_C = 25\text{ °C}$	10	mJ
	Single pulse avalanche energy at $T_C = 100\text{ °C}$	7	mJ
P_{TOT}	Total power dissipation at $T_C = 25\text{ °C}$	75	W
T_J	Operating junction temperature range	-55 to 150	°C
T_{stg}	Storage temperature range		

1. Pulse width is limited by maximum junction temperature
2. $V_{CLAMP} = 80\% V_{CES}$, $V_{GE} = 15\text{ V}$, $R_G = 10\ \Omega$, $T_J = 150\text{ °C}$
3. $V_{CE} = 50\text{ V}$, $I_{AV} = 3.3\text{ A}$

Table 2. Thermal data

Symbol	Parameter	Value	Unit
$R_{thj-case}$	Thermal resistance junction-case	1.67	°C/W
$R_{thj-amb}$	Thermal resistance junction-ambient	100	°C/W

2 Electrical characteristics

$T_C = 25\text{ °C}$ unless otherwise specified

Table 3. Static characteristics

Symbol	Parameter	Test conditions	Min.	Typ.	Max.	Unit
$V_{(BR)CES}$	Collector-emitter breakdown voltage	$V_{GE} = 0\text{ V}, I_C = 10\text{ mA}$	1200			V
$V_{CE(sat)}$	Collector-emitter saturation voltage	$V_{GE} = 15\text{ V}, I_C = 5\text{ A}$		1.3	2.0	V
		$V_{GE} = 15\text{ V}, I_C = 5\text{ A}, T_C = 125\text{ °C}$		1.2		
$V_{GE(th)}$	Gate threshold voltage	$V_{CE} = V_{GE}, I_C = 250\text{ }\mu\text{A}$	2		5	V
V_{GE}	Gate emitter voltage	$V_{CE} = 2.5\text{ V}, I_C = 2\text{ A},$ $T_C = 25\text{ to }125\text{ °C}$			6.5	V
I_{CES}	Collector cut-off current	$V_{GE} = 0\text{ V}, V_{CE} = 900\text{ V}$			50	μA
		$V_{GE} = 0\text{ V}, V_{CE} = 900\text{ V}, T_C = 125\text{ °C}^{(1)}$			250	μA
I_{GES}	Gate-emitter leakage current	$V_{GE} = \pm 20\text{ V}, V_{CE} = 0\text{ V}$			± 100	nA
R_G	Gate resistance			4		k Ω

1. Defined by design, not subject to production test.

Table 4. Dynamic characteristics

Symbol	Parameter	Test conditions	Min.	Typ.	Max.	Unit
C_{ies}	Input capacitance	$V_{CE} = 25\text{ V}, f = 1\text{ MHz}, V_{GE} = 0\text{ V}$	-	430	-	pF
C_{oes}	Output capacitance		-	40	-	
C_{res}	Reverse transfer capacitance		-	7	-	

Table 5. Switching characteristics (inductive load)

Symbol	Parameter	Test conditions	Min.	Typ.	Max.	Unit
$t_{d(on)}$	Turn-on delay time	$V_{CC} = 960\text{ V}$, $I_C = 5\text{ A}$, $R_G = 1\text{ k}\Omega$, $V_{GE} = 15\text{ V}$ (see Figure 16. Switching waveform)	-	690	-	ns
t_r	Current rise time		-	170	-	
$(di/dt)_{on}$	Turn-on current slope		-	39.6	-	
$t_{d(on)}$	Turn-on delay time	$V_{CC} = 960\text{ V}$, $I_C = 5\text{ A}$, $R_G = 1\text{ k}\Omega$, $V_{GE} = 15\text{ V}$, $T_J = 125\text{ }^\circ\text{C}$ (see Figure 16. Switching waveform)	-	600	-	ns
t_r	Current rise time		-	185	-	
$(di/dt)_{on}$	Turn-on current slope		-	39	-	
t_c	Cross-over time	$V_{CC} = 960\text{ V}$, $I_C = 5\text{ A}$, $R_G = 1\text{ k}\Omega$, $V_{GE} = 15\text{ V}$ (see Figure 16. Switching waveform)	-	4	-	μ s
$t_r(V_{off})$	Off voltage rise time		-	2.2	-	
$t_d(off)$	Turn-off delay time		-	12.1	-	
t_f	Current fall time		-	1.13	-	
t_c	Cross-over time		-	5	-	
$t_r(V_{off})$	Off voltage rise time		-	2.2	-	
$t_d(off)$	Turn-off delay time		-	12.1	-	
t_f	Current fall time		-	2	-	

Table 6. Switching energy (inductive load)

Symbol	Parameter	Test conditions	Min.	Typ.	Max.	Unit
$E_{on}^{(1)}$	Turn-on switching energy	$V_{CC} = 960\text{ V}$, $I_C = 5\text{ A}$, $R_G = 1\text{ k}\Omega$, $V_{GE} = 15\text{ V}$ (see Figure 16. Switching waveform)	-	2.59	-	mJ
$E_{off}^{(2)}$	Turn-off switching energy		-	9	-	
E_{ts}	Total switching energy		-	11.59	-	
$E_{on}^{(1)}$	Turn-on switching energy	$V_{CC} = 960\text{ V}$, $I_C = 5\text{ A}$, $R_G = 1\text{ k}\Omega$, $V_{GE} = 15\text{ V}$, $T_J = 125\text{ }^\circ\text{C}$ (see Figure 16. Switching waveform)	-	2.64	-	mJ
$E_{off}^{(2)}$	Turn-off switching energy		-	10.2	-	
E_{ts}	Total switching energy		-	12.68	-	

1. Including the reverse recovery of the diode.
2. Including the tail of the collector current.

Table 7. Functional test

Symbol	Parameter	Test conditions	Min.	Typ.	Max.	Unit
I_{AS}	Unclamped inductive switching current	$V_{CC} = 50\text{ V}$, $L = 1.8\text{ mH}$ $T_{start} = 25\text{ }^\circ\text{C}$, $R_g = 1\text{ k}\Omega$	3.3			A

2.1 Electrical characteristics curves

Figure 1. Output characteristics

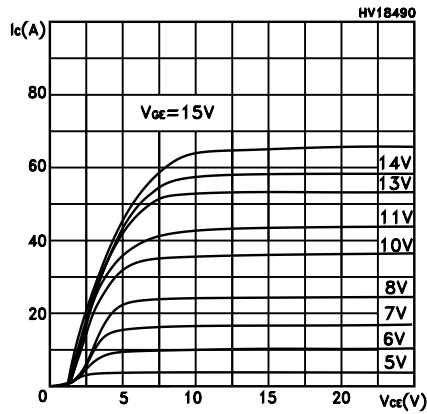

Figure 2. Transfer characteristics

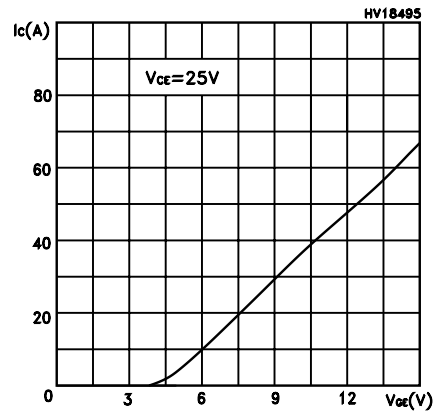

Figure 3. Collector-emitter on voltage vs temperature

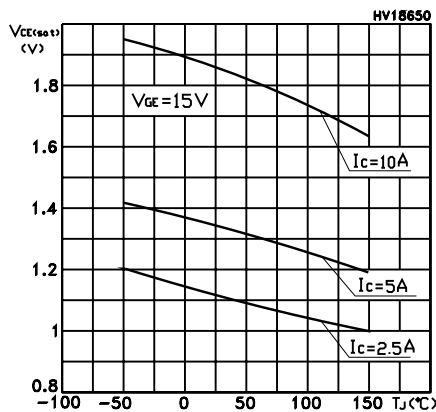

Figure 4. Gate charge vs gate-source voltage

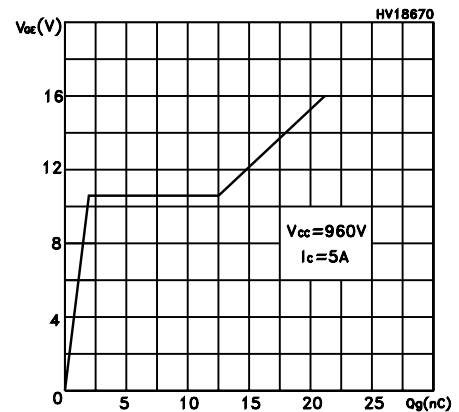

Figure 5. Capacitance variations

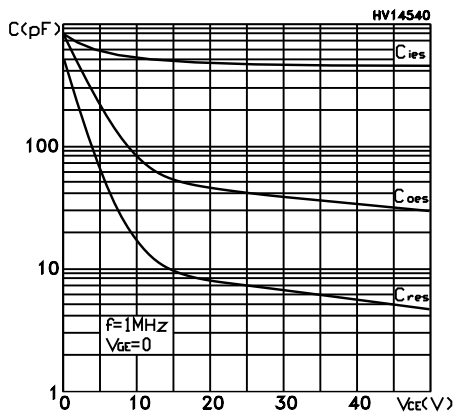

Figure 6. Normalized gate threshold voltage vs temperature

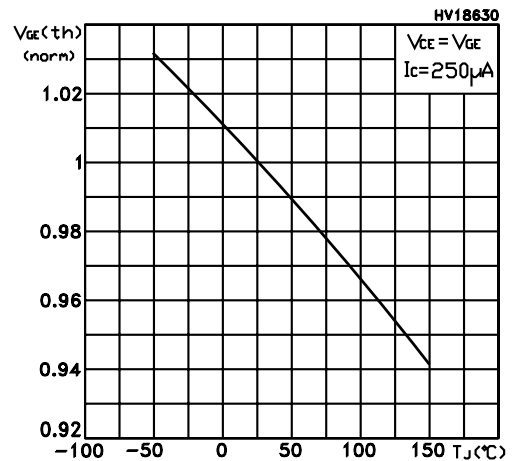

Figure 7. Collector-emitter on voltage vs collector current

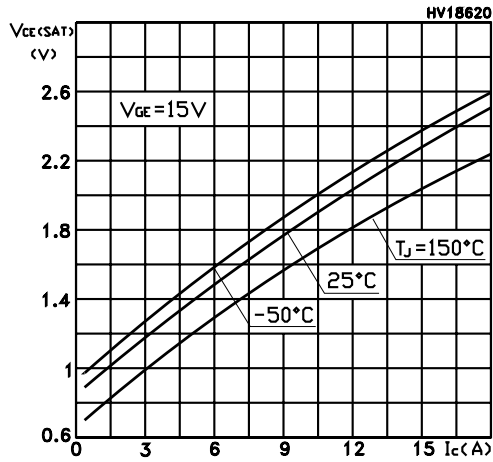

Figure 8. Breakdown voltage vs temperature

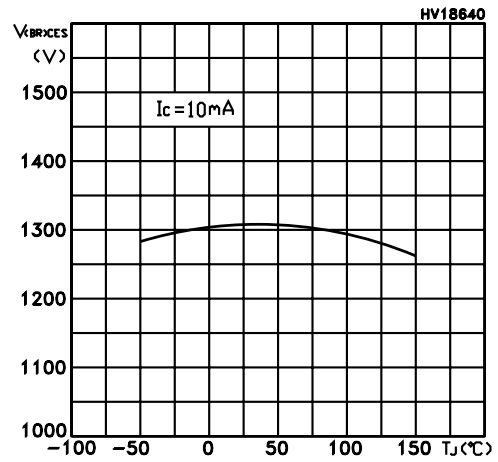

Figure 9. Normalized collector-emitter on voltage vs temperature

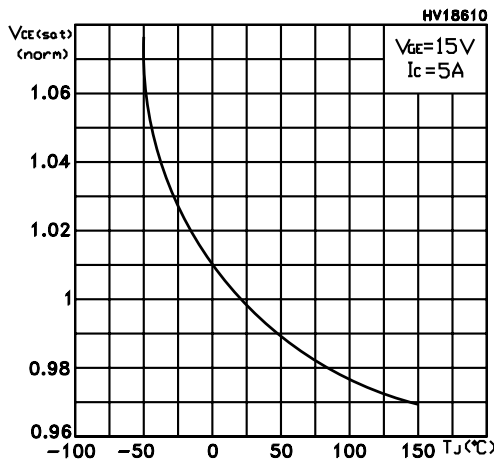

Figure 10. Switching energy vs gate resistance

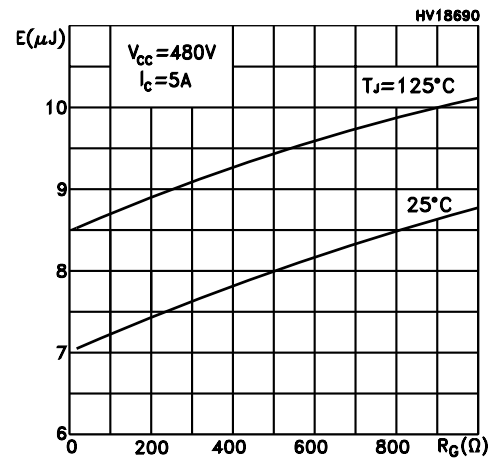

Figure 11. Switching energy vs collector current

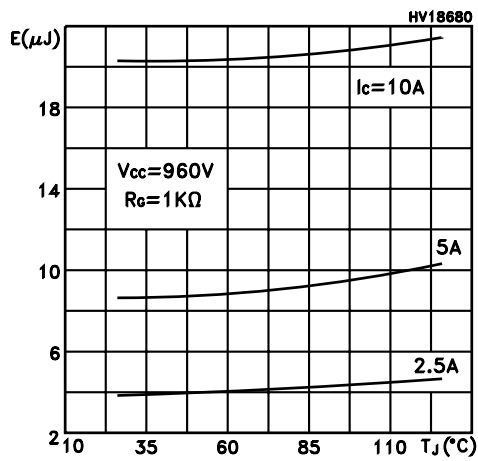

Figure 12. Turn-off SOA

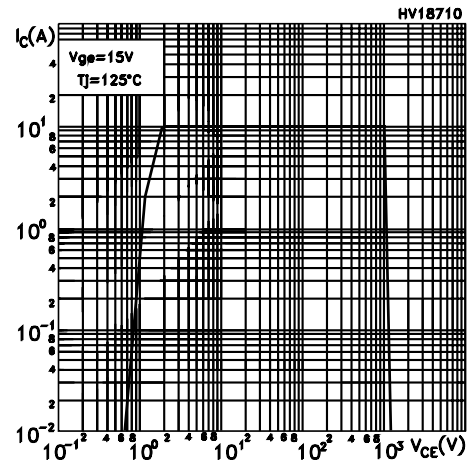
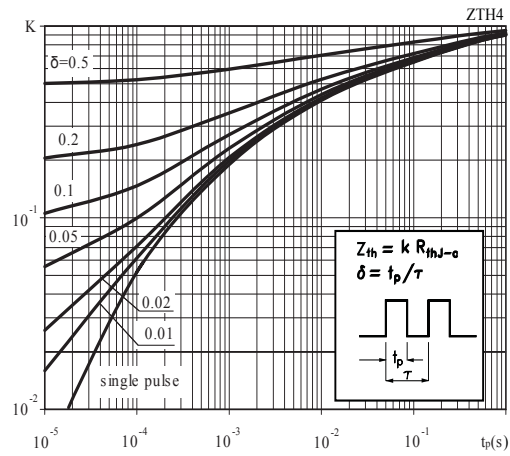
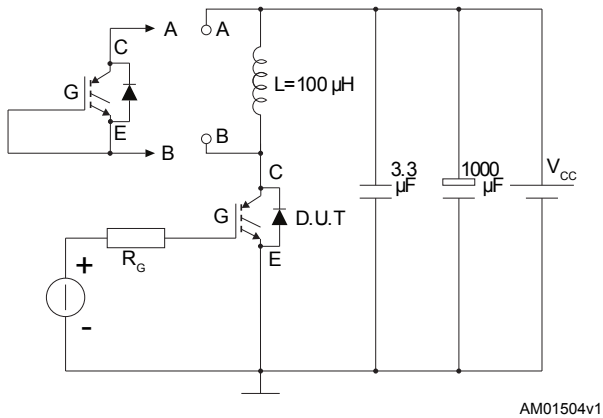
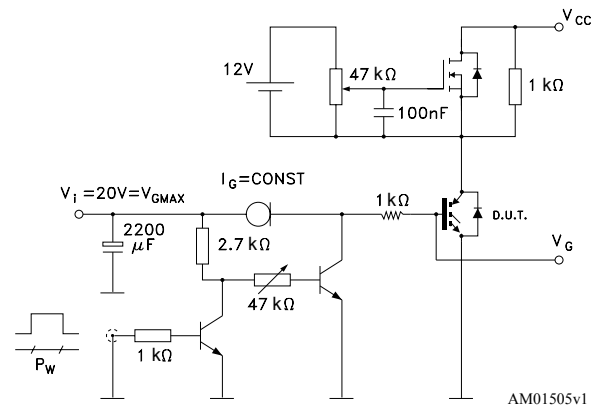
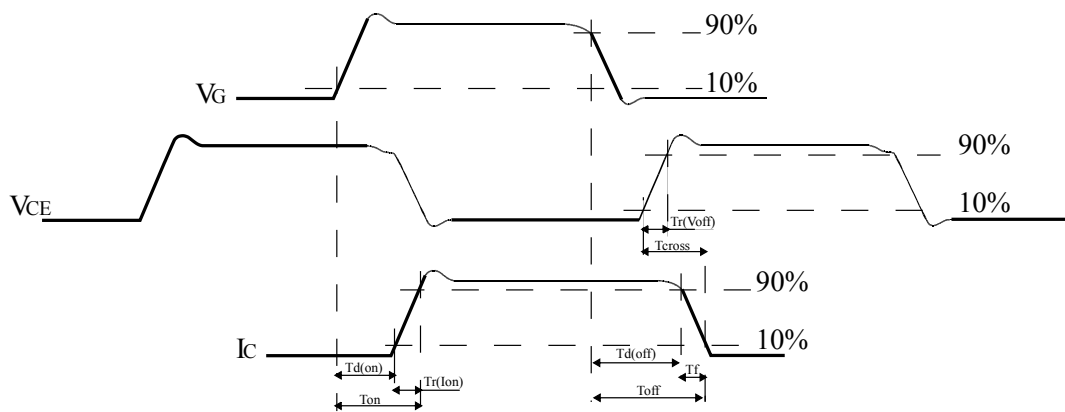

Figure 13. Thermal impedance



3 Test circuits

Figure 14. Test circuit for inductive load switching

Figure 15. Gate charge test circuit

Figure 16. Switching waveform

4 Package information

In order to meet environmental requirements, ST offers these devices in different grades of **ECOPACK®** packages, depending on their level of environmental compliance. ECOPACK® specifications, grade definitions and product status are available at: www.st.com. ECOPACK® is an ST trademark.

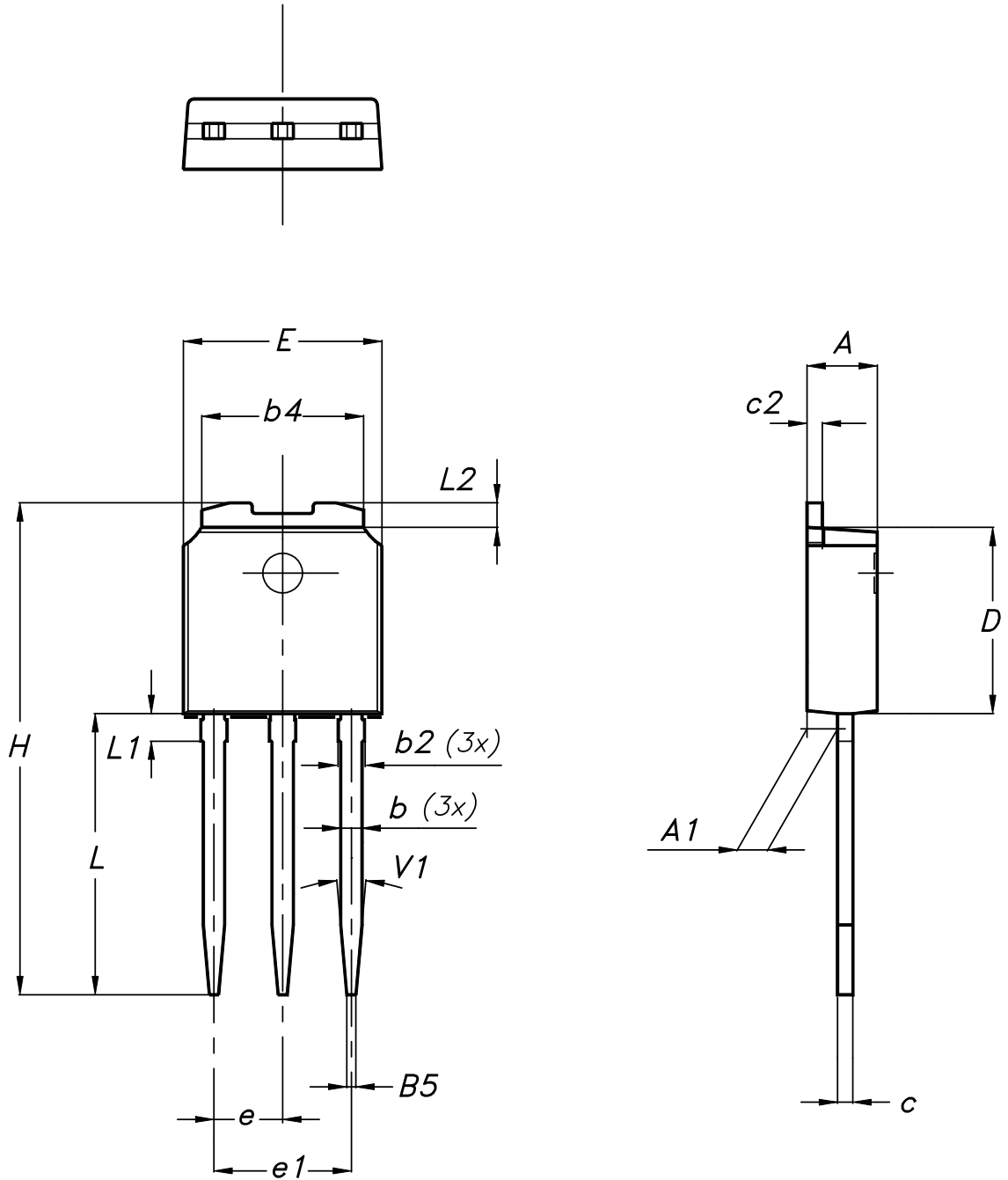
4.1 IPAK (TO-251) type A package information

Figure 17. IPAK (TO-251) type A package outline



0068771_IK_typeA_rev14

Table 8. IPAK (TO-251) type A package mechanical data

Dim.	mm		
	Min.	Typ.	Max.
A	2.20		2.40
A1	0.90		1.10
b	0.64		0.90
b2			0.95
b4	5.20		5.40
B5		0.30	
c	0.45		0.60
c2	0.48		0.60
D	6.00		6.20
E	6.40		6.60
e		2.28	
e1	4.40		4.60
H		16.10	
L	9.00		9.40
L1	0.80		1.20
L2		0.80	1.00
V1		10°	

4.2 DPAK (TO-252) type A2 package information

Figure 18. DPAK (TO-252) type A2 package outline

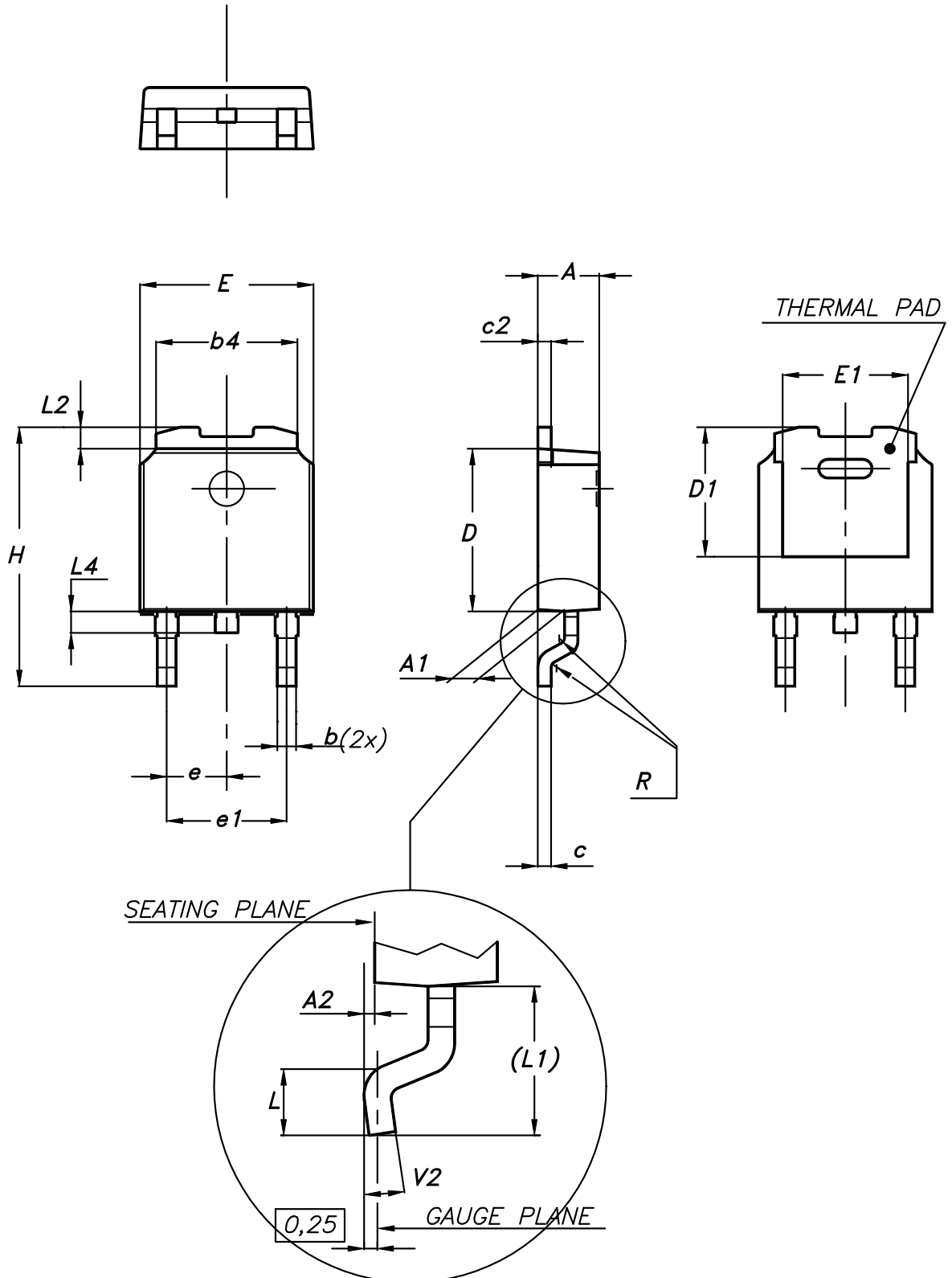

0068772_type-A2_rev26

Table 9. DPAK (TO-252) type A2 mechanical data

Dim.	mm		
	Min.	Typ.	Max.
A	2.20		2.40
A1	0.90		1.10
A2	0.03		0.23
b	0.64		0.90
b4	5.20		5.40
c	0.45		0.60
c2	0.48		0.60
D	6.00		6.20
D1	4.95	5.10	5.25
E	6.40		6.60
E1	5.10	5.20	5.30
e	2.159	2.286	2.413
e1	4.445	4.572	4.699
H	9.35		10.10
L	1.00		1.50
L1	2.60	2.80	3.00
L2	0.65	0.80	0.95
L4	0.60		1.00
R		0.20	
V2	0°		8°

4.3 DPAK (TO-252) type C2 package information

Figure 19. DPAK (TO-252) type C2 package outline

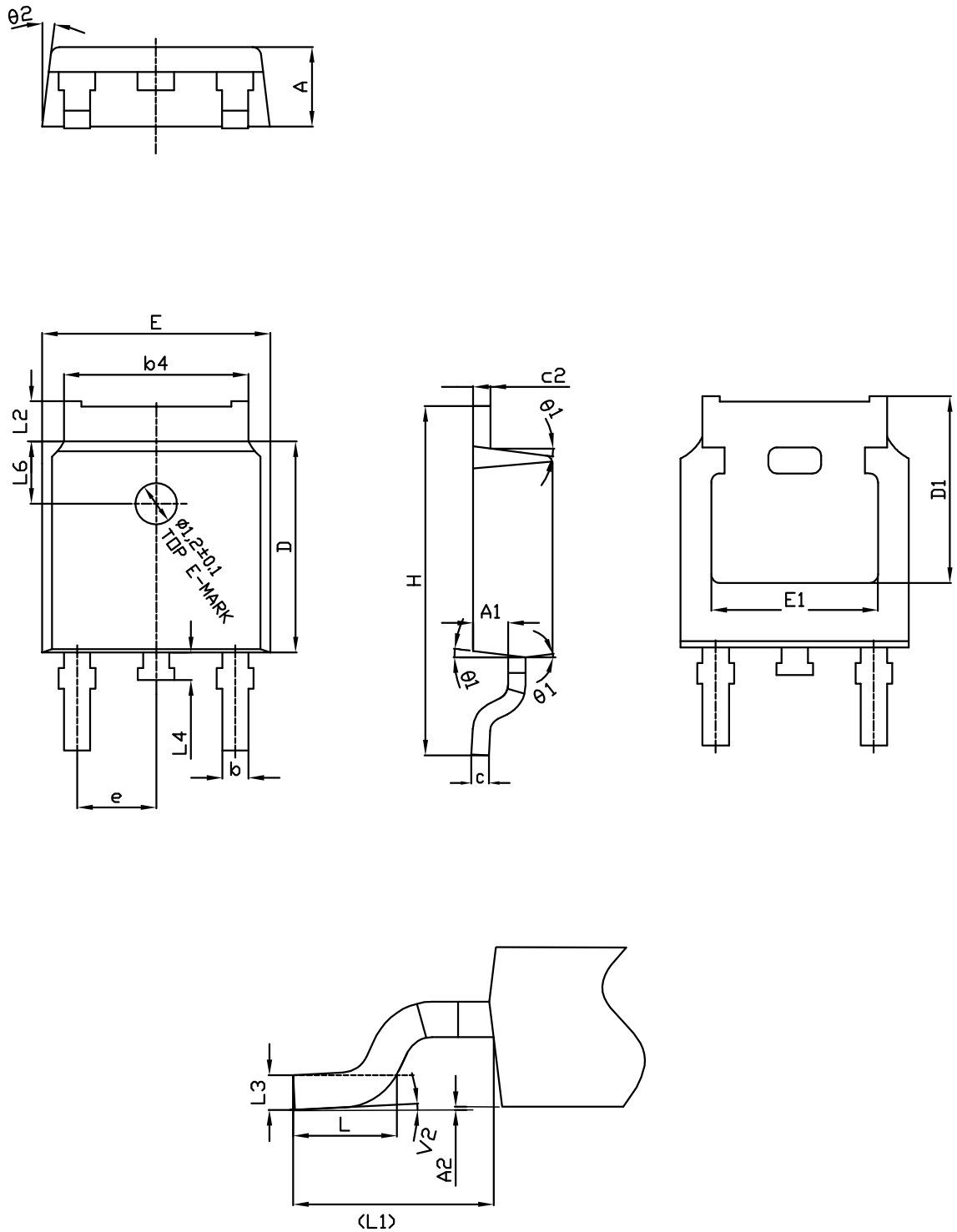
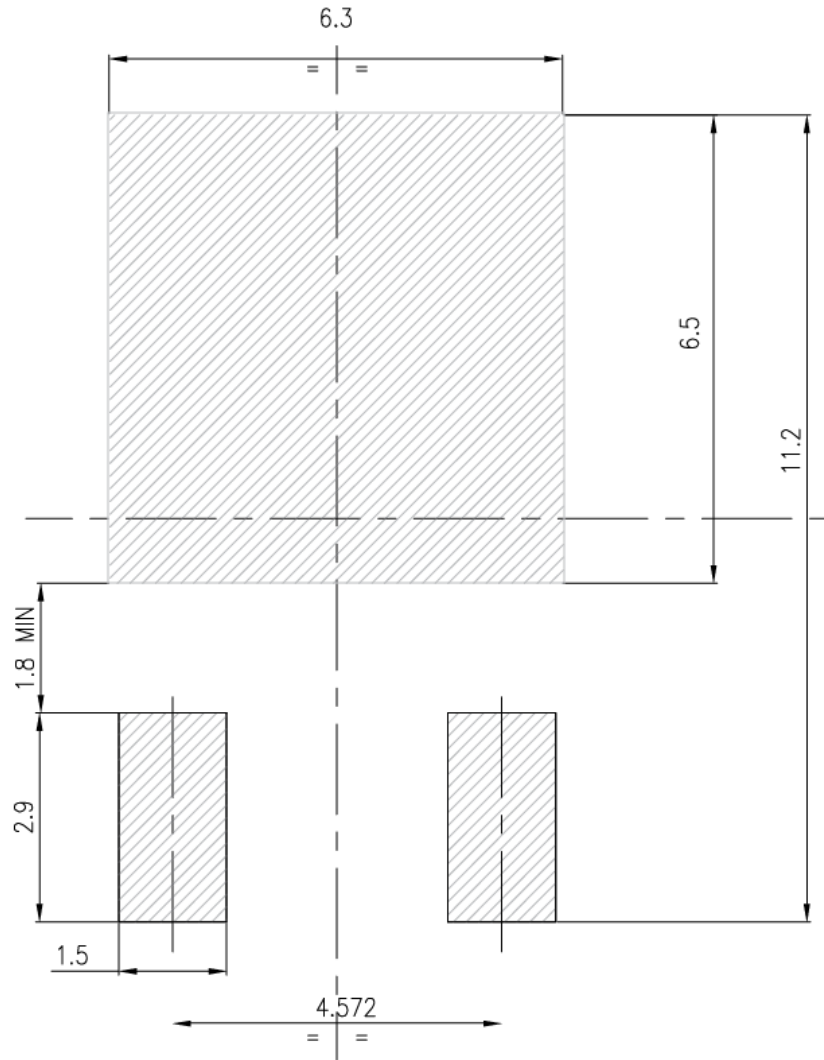

Table 10. DPAK (TO-252) type C2 mechanical data

Dim.	mm		
	Min.	Typ.	Max.
A	2.20	2.30	2.38
A1	0.90	1.01	1.10
A2	0.00		0.10
b	0.72		0.85
b4	5.13	5.33	5.46
c	0.47		0.60
c2	0.47		0.60
D	6.00	6.10	6.20
D1	5.10		5.60
E	6.50	6.60	6.70
E1	5.20		5.50
e	2.186	2.286	2.386
H	9.80	10.10	10.40
L	1.40	1.50	1.70
L1	2.90 REF		
L2	0.90		1.25
L3	0.51 BSC		
L4	0.60	0.80	1.00
L6	1.80 BSC		
θ1	5°	7°	9°
θ2	5°	7°	9°
V2	0°		8°

Figure 20. DPAK (TO-252) recommended footprint (dimensions are in mm)



FP_0068772_rev26

4.4 DPAK (TO-252) packing information

Figure 21. DPAK (TO-252) tape outline

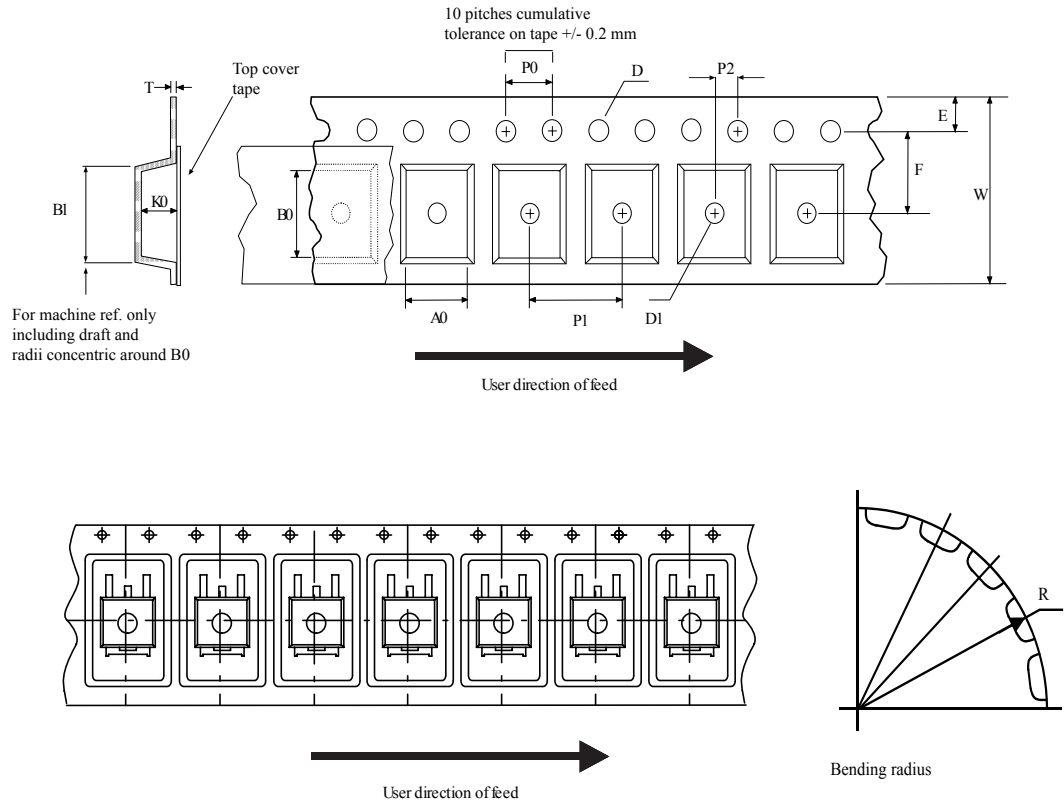

AM08852v1

Figure 22. DPAK (TO-252) reel outline

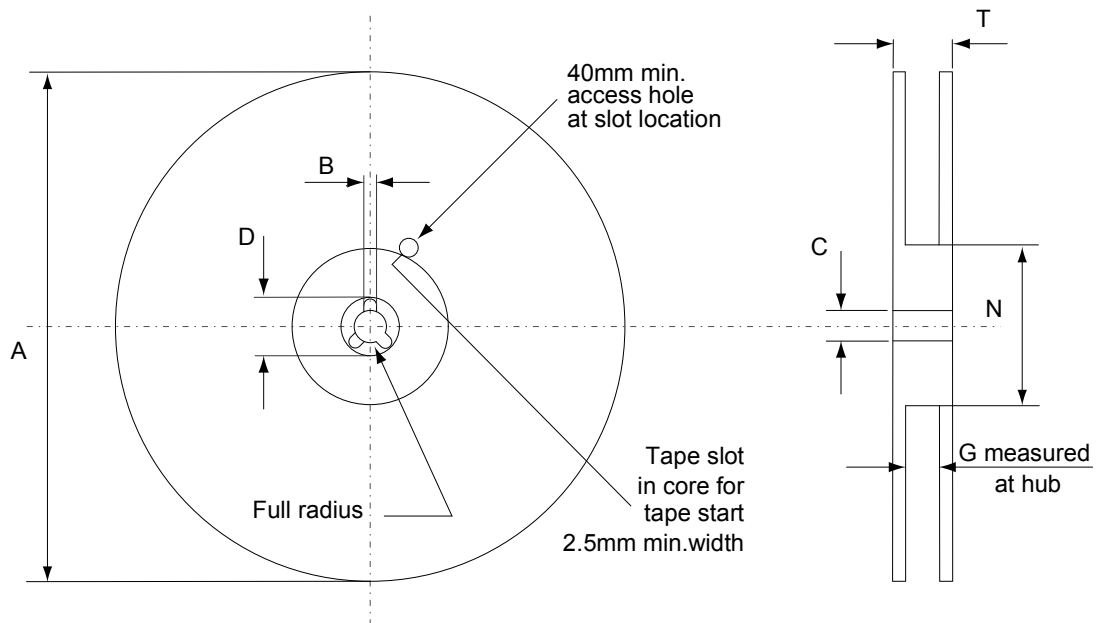

AM06038v1

Table 11. DPAK (TO-252) tape and reel mechanical data

Dim.	Tape		Dim.	Reel	
	mm			mm	
	Min.	Max.		Min.	Max.
A0	6.8	7	A		330
B0	10.4	10.6	B	1.5	
B1		12.1	C	12.8	13.2
D	1.5	1.6	D	20.2	
D1	1.5		G	16.4	18.4
E	1.65	1.85	N	50	
F	7.4	7.6	T		22.4
K0	2.55	2.75			
P0	3.9	4.1		Base qty.	2500
P1	7.9	8.1		Bulk qty.	2500
P2	1.9	2.1			
R	40				
T	0.25	0.35			
W	15.7	16.3			

5 Ordering information

Table 12. Order codes

Order code	Marking	Package	Packing
STGD5NB120SZ-1	GD5NB120SZ	IPAK	Tube
STGD5NB120SZT4	GD5NB120SZ	DPAK	Tape e reel

Revision history

Table 13. Document revision history

Date	Version	Changes
06-Oct-2003	5	No history because migration
18-Jan-2005	6	Final datasheet
13-Nov-2008	7	Insert new value in <i>Table 2: Absolute maximum ratings</i>
08-Jan-2019	8	The document status is production data. Updated Section 4 Package information . Minor text changes.

Contents

1	Electrical ratings	2
2	Electrical characteristics	3
2.1	Electrical characteristics curves	4
3	Test circuits	8
4	Package information	9
4.1	IPAK (TO-251) type A package information	9
4.2	DPAK (TO-252) type A2 package information	11
4.3	DPAK (TO-252) type C2 package information	13
4.4	DPAK (TO-252) packing information	16
5	Ordering information	19
	Revision history	20

IMPORTANT NOTICE – PLEASE READ CAREFULLY

STMicroelectronics NV and its subsidiaries (“ST”) reserve the right to make changes, corrections, enhancements, modifications, and improvements to ST products and/or to this document at any time without notice. Purchasers should obtain the latest relevant information on ST products before placing orders. ST products are sold pursuant to ST’s terms and conditions of sale in place at the time of order acknowledgement.

Purchasers are solely responsible for the choice, selection, and use of ST products and ST assumes no liability for application assistance or the design of Purchasers’ products.

No license, express or implied, to any intellectual property right is granted by ST herein.

Resale of ST products with provisions different from the information set forth herein shall void any warranty granted by ST for such product.

ST and the ST logo are trademarks of ST. All other product or service names are the property of their respective owners.

Information in this document supersedes and replaces information previously supplied in any prior versions of this document.

© 2019 STMicroelectronics – All rights reserved



Компания «ЭлектроПласт» предлагает заключение долгосрочных отношений при поставках импортных электронных компонентов на взаимовыгодных условиях!

Наши преимущества:

- Оперативные поставки широкого спектра электронных компонентов отечественного и импортного производства напрямую от производителей и с крупнейших мировых складов;
- Поставка более 17-ти миллионов наименований электронных компонентов;
- Поставка сложных, дефицитных, либо снятых с производства позиций;
- Оперативные сроки поставки под заказ (от 5 рабочих дней);
- Экспресс доставка в любую точку России;
- Техническая поддержка проекта, помощь в подборе аналогов, поставка прототипов;
- Система менеджмента качества сертифицирована по Международному стандарту ISO 9001;
- Лицензия ФСБ на осуществление работ с использованием сведений, составляющих государственную тайну;
- Поставка специализированных компонентов (Xilinx, Altera, Analog Devices, Intersil, Interpoint, Microsemi, Aeroflex, Peregrine, Syfer, Eurofarad, Texas Instrument, Miteq, Cobham, E2V, MA-COM, Hittite, Mini-Circuits, General Dynamics и др.);

Помимо этого, одним из направлений компании «ЭлектроПласт» является направление «Источники питания». Мы предлагаем Вам помощь Конструкторского отдела:

- Подбор оптимального решения, техническое обоснование при выборе компонента;
- Подбор аналогов;
- Консультации по применению компонента;
- Поставка образцов и прототипов;
- Техническая поддержка проекта;
- Защита от снятия компонента с производства.



Как с нами связаться

Телефон: 8 (812) 309 58 32 (многоканальный)

Факс: 8 (812) 320-02-42

Электронная почта: org@eplast1.ru

Адрес: 198099, г. Санкт-Петербург, ул. Калинина, дом 2, корпус 4, литера А.