

# TREK-550



## Intel® Atom™ In-Vehicle Computing Box

### Features

- Supports Win CE 6.0, WES 2009, XP and Linux (Ubuntu 10.04/2.6.34)
- Automotive grade working temperature range (-30 to 70° C)
- Rich I/O including CAN, LAN, RS-232, RS-485, J1708, 4DI/4DO (isolated), Line out, Mic in, USB, and Video-in
- Built-in communication modules, including GPRS/HSDPA/CDMA, WLAN & Bluetooth
- GPS with AGPS and dead reckoning technology (Gyro & speed line)
- Certifications: CE/FCC/E-mark, MIL-STD-810G, ISO 7637-2, SAE J1455, SAE J1113 regulations
- Dual independent display/audio output for both driver and passenger
- Ignition on/off delay; SW controllable for car power management



## Introduction

The TREK-550 is a dedicated box computer for industrial vehicle fleets, transport trucks, buses and taxis. TREK-550 combined with variety of I/O connectors can be connected to devices like OBD-II or TPMS (Tire Pressure Monitoring Systems). Dual display/dual audio interfaces supporting different resolutions can deliver different applications to different displays; eg: one application to a fleet driver and another to a digital signage application.

Built-in wireless communications (WWAN, WLAN, BT) enable TREK-550 to send important driver/vehicle/location/cargo information back to the control center. TREK-550 can also operate in extreme environments with features like a wide working temperature range (-30 to 70° C). TREK-550 also uses a special design to handle the critical issue of in-vehicle power. Special power protection (ISO7637-2/SAE J1455 Class A/ SAE J1113) and car power management software (Ignition on/off, delay on/off, low battery monitor) prevent electrical noise and surges from impacting the system, guarding against damage from transient car power. TREK-550 also supports a rear view monitor via a video port connection. With this feature, drivers can monitor the environment on both sides of the truck in real-time for driving safety. TREK-550 can also support dead-reckoning, meaning the truck can still be traced even when the driver is driving in a tunnel.

## Specifications

System	CPU	Intel Atom XL Z510PT 1.1 GHz (Z520PT 1.3 GHz is optional) (Industrial grade)
	Chipset	Intel LE82US15EE
	System Memory	1 x 200-pin SODIMM socket; Supports up to 2 GB industrial DDR2 400/533 memory module
Physical	Dimensions (W x H x D)	266 x 149 x 69.7 mm
	Weight	2 kg
Storage	Compact Flash	1x Type II (externally accessible)
Display interface	Smart Display Port	Design compatible with TREK-303H, 7" smart display signal includes: <ul style="list-style-type: none"> <li>18-bit LVDS out</li> <li>2 x RS-232 ports</li> <li>Mono audio out</li> <li>1 x USB host</li> <li>12V DC output @ 1A output</li> </ul>
I/O	CAN	1 x CAN 2.0 A/B (J1939 protocol is ready, 2500Vrms isolation protection) via box header
	Video In	2 x composite video inputs for rear view monitor; bypass to digital display port; doesn't support video recording (NTSC, PAL, SECAM with automatic format detection)
	USB Host	3 x USB host ports type A connectors with cable clip (front I/O panel x1; rear I/O panel x2)
	Mic In	1 x Mic-in jack with cable clip
	Line Out	1 x line out jack with cable clip
	COM Ports	2 x full function RS-232 ports, 5 V @ 500 mA, 12 V @ 250 mA, ping9, jumper selected <ul style="list-style-type: none"> <li>1 x 4-wire RS-232, 1 x RS485, 1 x J1708</li> </ul>
	Isolated DI/DO	4 x isolated dry contact digital inputs via DB9 (2500 Vrms protection) <ul style="list-style-type: none"> <li>4 x relay drivers via DB9</li> </ul>
	VGA Output	1 x VGA output via DB-15 (independent display)
	LAN	1 x 10/100/1000 Ethernet (with LEDs) via RJ-45 with cable clips
	Communication	WWAN
WLAN		Optional, supports 802.11 b/g/n, with SMA connector for external antenna (through internal Mini PCI Express)
Bluetooth		Optional, supports Bluetooth Class II, Version 2.0 + EDR, antenna built-in
GPS	Model	ublox industrial grade LEA 5S
	RF Receiver Type	50 channels GPS L1 frequency, C/A code
	Cold Start	29 s
	Warm Start	29 s
	Hot Start	<1 s
	AGPS	<5 s
	Acquisition	160 dBm
G sensor	Protocol	NMEA (Input/Output, ASCII, 0183.2.3 (compatible to 3.0)) UBX (u-blox proprietary protocol) (Note: Dead Reckoning optional)
		Built-in <ul style="list-style-type: none"> <li>Power (Red)</li> <li>Storage Access (Green)</li> <li>WLAN data transfer (Green)</li> <li>WWAN link (Green)</li> <li>GPS operation (Blue)</li> </ul>
LED	LED Indicator	

# TREK-550

## Specifications Cont.

Car Power Design	DC-input	Supports 12/24 V car power system by ISO7637-2 & SAEJ1113 (6V - 36V wide DC input)
	Power Management	Power on/off delay, <ul style="list-style-type: none"> <li>▪ Power on delay, 2 sec default</li> <li>▪ Power off delay, 5 sec as default</li> <li>▪ Delay time controllable by SW configuration</li> <li>▪ Low voltage protection</li> </ul>
Environment	HW Reset	1 reset button
	IP Rating	IP 31
	Operating Temp.	-30° C ~ +70° C
	Storage Temp.	-40° C ~ +85° C
Certifications	Vibration/Shock	MIL-STD-810G/ 202A, Method 516.5, EN60721-3 (5M3) compliant
	EMC	CE, FCC, IC
Mechanical	Safety	CE, CB
	Vehicle Power Regulation	E-mark, SAE J1455, SAE J1113, ISO7637-2 level IV compliant
Mechanical	Material	Top cover (Aluminum extrusion)
		Side cover (PC)
		Bottom & I/O cover (metal)

## Dimensions

Unit: mm

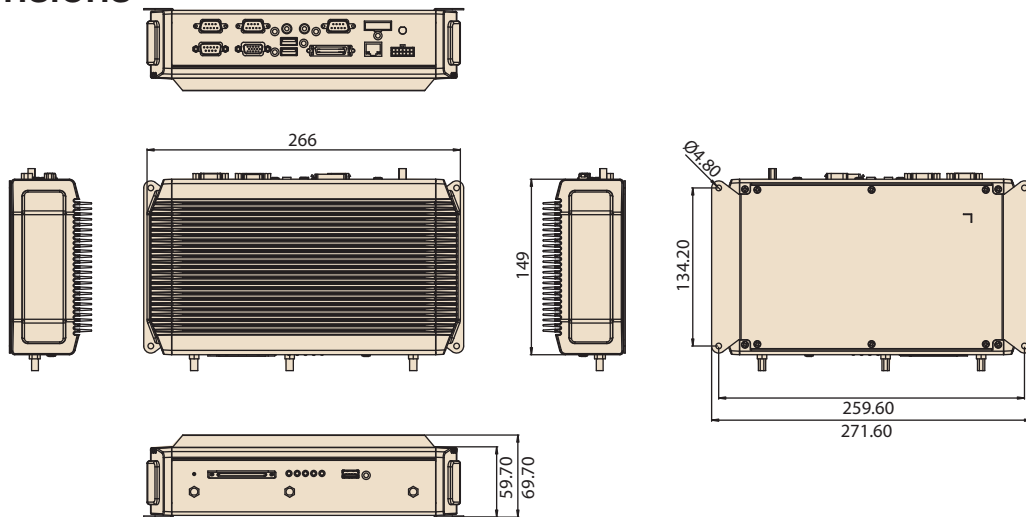

## Ordering Information

Part Number	Description
TREK-550-00A1E	Intel Atom Z510PT 1.1 GHZ GPRS Barebone
TREK-550-01A1E	Intel Atom Z510PT 1.1 GHZ HSXPA CDMA Barebone
TREK-550-10A1E	Intel Atom Z520PT 1.3 GHZ GPRS Barebone
TREK-550-11A1E	Intel Atom Z520PT 1.3 GHZ HSXPA / CDMA Barebone
9668TREK20E	Cinterion MC55i 4 Band GPRS Kit
9668TREK21E	Sierra Wireless 5728V CDMA Module Kit
9668TREK22E	Sierra Wireless 8790V HSUPA Module Kit
9668TREK23E	802.11 B/G/N Module Kit
9668TREK25E	u-blox LEA-5S GPS Module Kit

(Note: Module kits include RF, antenna and internal cable)

## Packing List

Description	Part Number	Quantity
TREK-550		x1
CAN/Video-in cable (15 cm)	1700018743	x1
Power cable (1.8 m)	1700018306	x1
Startup manual CD	2068055000	x1
Cable clip for Mic in, line out, USB host, LAN	1990018848T000	x6

## I/O Connectors

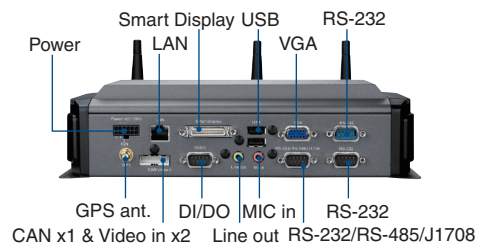
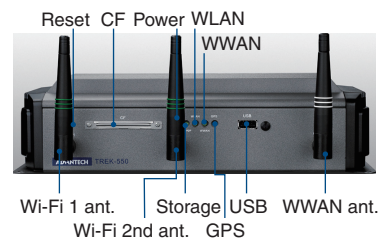



Компания «ЭлектроПласт» предлагает заключение долгосрочных отношений при поставках импортных электронных компонентов на взаимовыгодных условиях!

Наши преимущества:

- Оперативные поставки широкого спектра электронных компонентов отечественного и импортного производства напрямую от производителей и с крупнейших мировых складов;
- Поставка более 17-ти миллионов наименований электронных компонентов;
- Поставка сложных, дефицитных, либо снятых с производства позиций;
- Оперативные сроки поставки под заказ (от 5 рабочих дней);
- Экспресс доставка в любую точку России;
- Техническая поддержка проекта, помощь в подборе аналогов, поставка прототипов;
- Система менеджмента качества сертифицирована по Международному стандарту ISO 9001;
- Лицензия ФСБ на осуществление работ с использованием сведений, составляющих государственную тайну;
- Поставка специализированных компонентов (Xilinx, Altera, Analog Devices, Intersil, Interpoint, Microsemi, Aeroflex, Peregrine, Syfer, Eurofarad, Texas Instrument, Miteq, Cobham, E2V, MA-COM, Hittite, Mini-Circuits, General Dynamics и др.);

Помимо этого, одним из направлений компании «ЭлектроПласт» является направление «Источники питания». Мы предлагаем Вам помощь Конструкторского отдела:

- Подбор оптимального решения, техническое обоснование при выборе компонента;
- Подбор аналогов;
- Консультации по применению компонента;
- Поставка образцов и прототипов;
- Техническая поддержка проекта;
- Защита от снятия компонента с производства.



#### Как с нами связаться

**Телефон:** 8 (812) 309 58 32 (многоканальный)

**Факс:** 8 (812) 320-02-42

**Электронная почта:** [org@eplast1.ru](mailto:org@eplast1.ru)

**Адрес:** 198099, г. Санкт-Петербург, ул. Калинина, дом 2, корпус 4, литера А.