

PLEASE CHECK WWW.MOLEX.COM FOR LATEST PART INFORMATION

Part Number: [0533643671](#)
Status: **Active**
Description: 0.80mm (.031") Pitch Board-to-Board Header, Surface Mount, Dual Row, Vertical, 6.00 and 7.00mm (.236 and .276") Stacking Heights, Lead-free, 36 Circuits

Documents:

[3D Model](#) [Product Specification PS-52465-010 \(PDF\)](#)
[Drawing \(PDF\)](#) [RoHS Certificate of Compliance \(PDF\)](#)

General

Product Family PCB Headers
 Series 53364
 Application Board-to-Board
 Product Name N/A

Physical

Breakaway No
 Circuits (Loaded) 36
 Circuits (maximum) 36
 Color - Resin Natural
 Durability (mating cycles max) 30
 First Mate / Last Break No
 Glow-Wire Compliant No
 Guide to Mating Part No
 Keying to Mating Part None
 Lock to Mating Part Yes
 Mated Height (in) 0.236 In, 0.276 In
 Mated Height (mm) 6.00 mm, 7.00 mm
 Material - Plating Mating Tin
 Material - Resin High Temperature Thermoplastic
 Number of Rows 2
 Orientation Vertical
 PC Tail Length (in) 0.020 In
 PC Tail Length (mm) 0.50 mm
 PCB Locator No
 PCB Retention None
 Packaging Type Embossed Tape on Reel
 Pitch - Mating Interface (in) 0.031 In
 Pitch - Mating Interface (mm) 0.80 mm
 Polarized to Mating Part Yes
 Polarized to PCB No
 Shrouded Fully
 Stackable No
 Temperature Range - Operating -20°C to +105°C
 Termination Interface: Style Surface Mount

Electrical

Current - Maximum per Contact 0.5A
 Voltage - Maximum 50V

Material Info

Reference - Drawing Numbers

Product Specification PS-52465-010, RPS-52465-048
 Sales Drawing SD-53364-**71, SD-53364-003

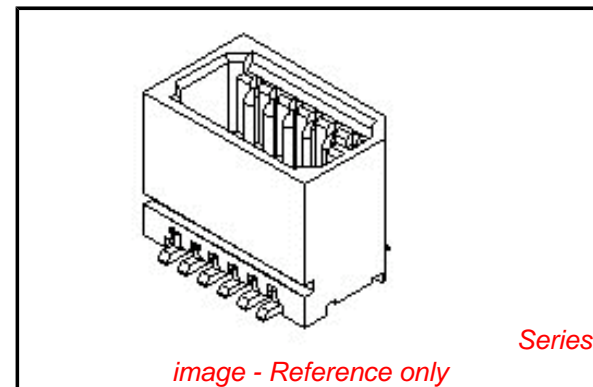

EU RoHS

ELV and RoHS Compliant
REACH SVHC
 Not Reviewed
Halogen-Free Status
Not Reviewed

China RoHS



Need more information on product environmental compliance?

Email productcompliance@molex.com
 For a multiple part number RoHS Certificate of Compliance, [click here](#)

Please visit the [Contact Us](#) section for any non-product compliance questions.

Search Parts in this Series

53364Series

Mates With

52465 PCB Receptacle. 52588 PCB Receptacle Floating Type

This document was generated on 04/21/2010

PLEASE CHECK WWW.MOLEX.COM FOR LATEST PART INFORMATION

DWG. NO. SD-53364-**-71

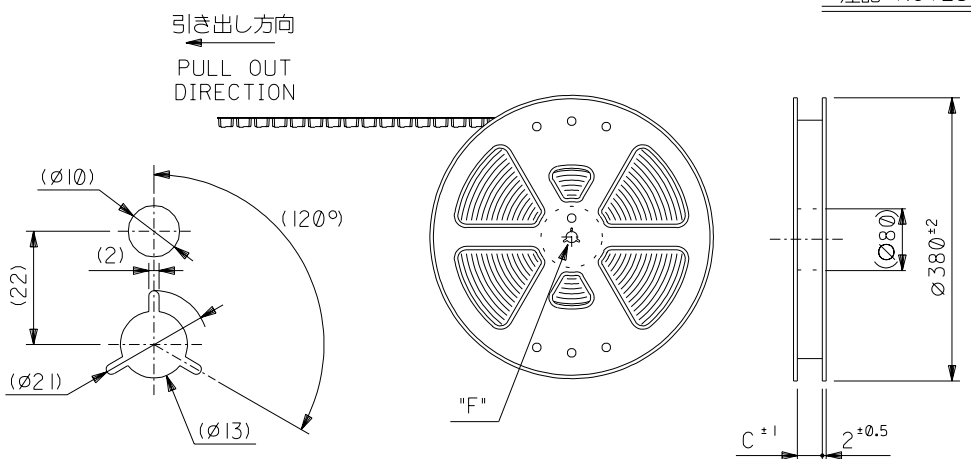

注記 NOTES

1. 梱包数量：1000個/リール NUMBER OF CONNECTORS:1000PCS/REEL
2. リードテープ長さ LEAD TAPE LENGTH

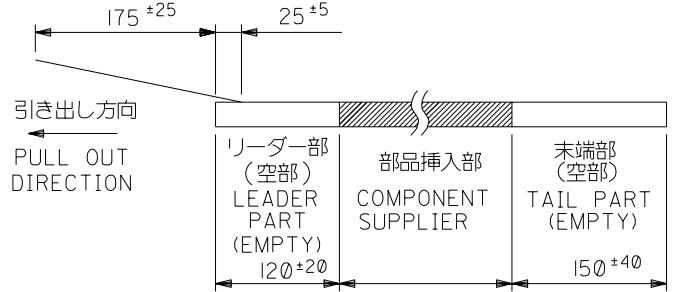

3. トップテープの剥離強度：(剥離方向は下図参照)
0.1N ~ 1.3N(10gf ~ 130gf) 尚、本規格値は、出荷時に適用。
(但し、輸送時に剥離が発生しない事。)
- PEELING OFF FORCE OF TOP TAPE
0.1N ~ 1.3N(10gf ~ 130gf) (PEELING DIRECTION AS SHOWN IN FOLLOWING FIG.)
THIS REQUIREMENT SHOULD BE APPLIED AT SHIPMENT
PEEL OFF SHOULD NOT BE ALLOWED,
DURING TRANSPORTATION

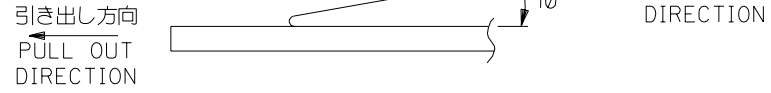

4. 材料 MATERIAL
キャリアテープ：ポリプロピレン (PP) CARRIER TAPE:POLYPROPYLENE
トップテープ：PET, PE, PEF TOP TAPE:PET,PE,PEF
リール：ポリスチレン (PS) REEL:POLYSTYREN(PS)
<リサイクル材を含む> <RECYCLE MATERIAL CONTAINED>
5. 本製品は 53364-**-91 の鉛フリー品である。
THIS PRODUCT IS LEAD FREE OF 53364-**-91.

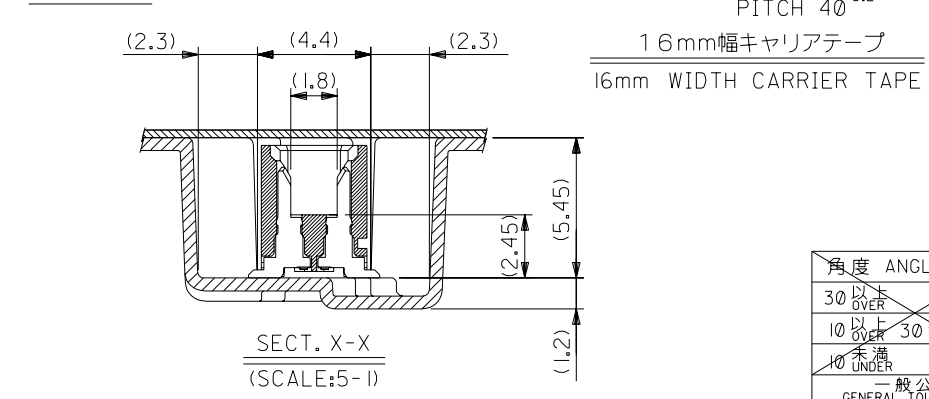
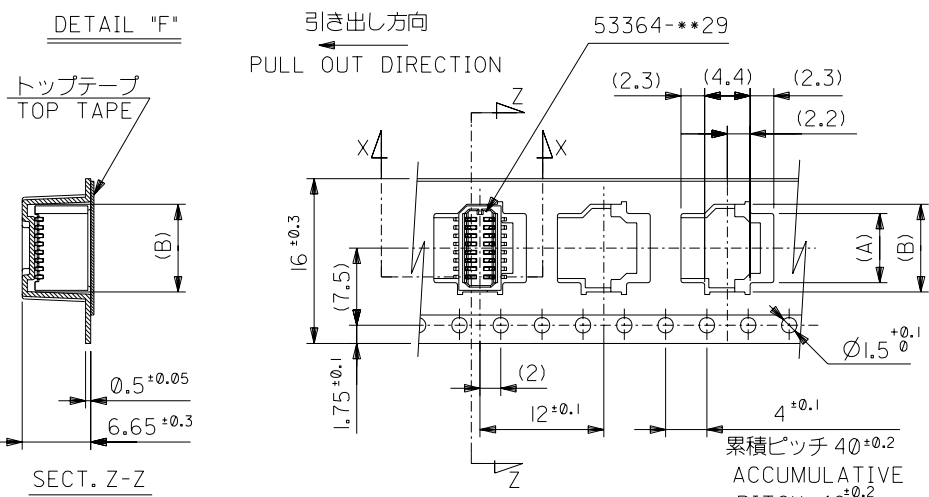

16	17.5	9.3	7.5	53364-1871	18
		6.9	5.1	53364-1271	12
		6.1	4.3	53364-1071	10
キャリアテープ幅 CARRIER TAPE WIDTH	C (B) (A)	MATERIAL. NO.		極数 CIRCUIT	

材料 MATERIAL 注記参照 SEE NOTES		molex MOLEX-JAPAN CO.,LTD. 日本モレックス株式会社	
仕上げ FINISH —		REVISE ONLY ON CAD SYSTEM	
適用電線範囲 WIRE RANGE —		TITLE 名称	
被覆外径 INS. RANGE —		0.8 BtB Conn Wafer Assy ST SMT Without Boss Embstp Pkg -LEAD FREE-	
DRAWN BY '03/12/11 M.NINOMIYA	CHK'D BY '03/12/11 K.TOJO	DWG. NO. (SHEET 1 OF 2)	REV
APP'D BY '03/12/11 M.SASAO	尺度 SCALE —	SD-53364-**-71	0

角度 ANGLE	±3°
30 以上 OVER	±0.3
10 以上 30 未満 UNDER	±0.25
未満 10 UNDER	±0.2
一般公差 GENERAL TOLERANCES	

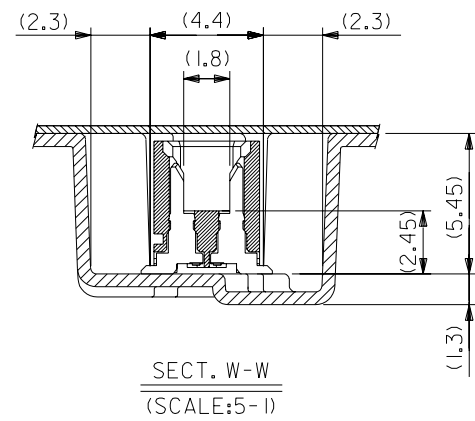
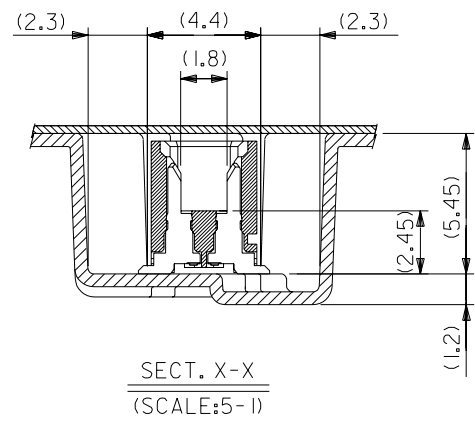
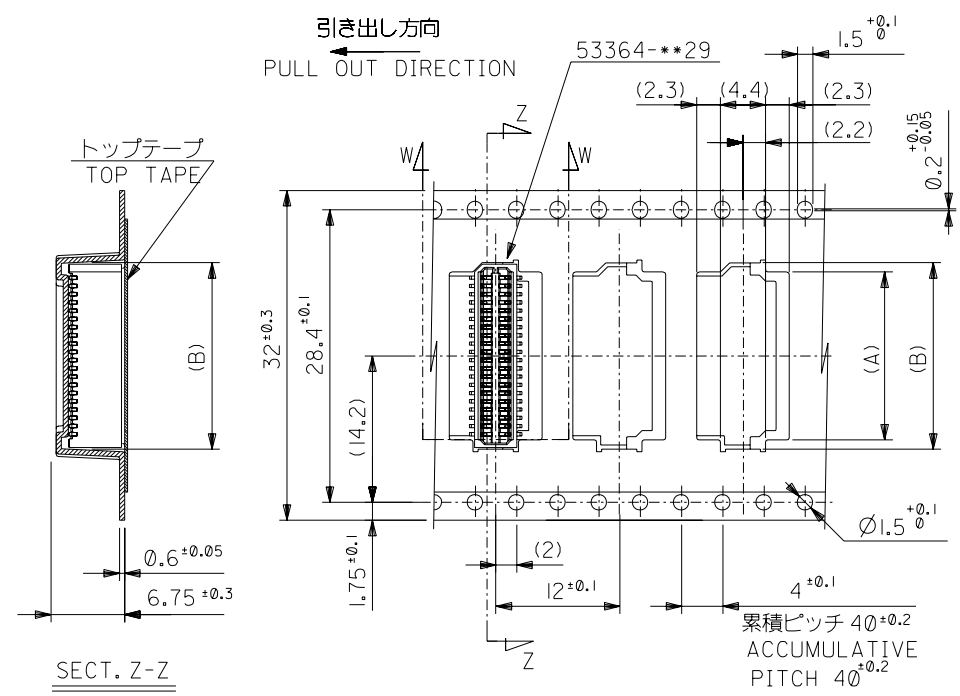
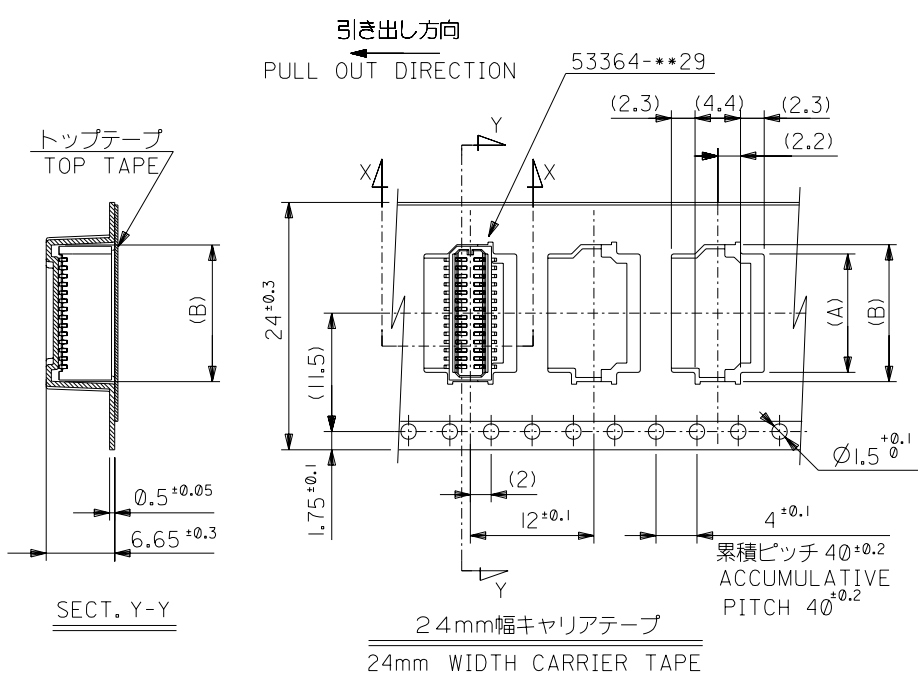

32	33.5	18.9	17.1	53364-4271	42
		18.1	16.3	53364-4071	40
24	25.5	16.5	14.7	53364-3671	36
		14.1	12.3	53364-3071	30
		13.3	11.5	53364-2871	28
		10.1	8.3	53364-2071	20
キャリアテープ幅 CARRIER TAPE WIDTH	C	(B)	(A)	MATERIAL NO.	極数 CIRCUIT

材料 MATERIAL	SHEET 1 OF 2 参照 REFER TO SHEET 1 OF 2		molex MOLEX-JAPAN CO.,LTD. 日本モレックス株式会社	
仕上げ FINISH	—#—		REVISE ONLY ON CAD SYSTEM	
適用電線範囲 WIRE RANGE	—#—		TITLE 名称	
被覆外径 INS. RANGE	—#—		0.8 BtB Conn Wafer Assy ST SMT Without Boss Embstp Pkg -LEAD FREE-	
DRAWN BY '03/12/11 M.NINOMIYA	CHK'D BY '03/12/11 K.TOJO	DR. '03/12/11 M.SASAO	尺度 SCALE	—#—
DWG. NO. (SHEET 2 OF 2) SD-53364-**-71	REV 0			

角度 ANGLE	±30°
30以上 OVER	±0.3
10以上 30未満 UNDER	±0.25
10未満 UNDER	±0.2
一般公差 GENERAL TOLERANCES	

10 9 8 7 6 5 4 3 2 1

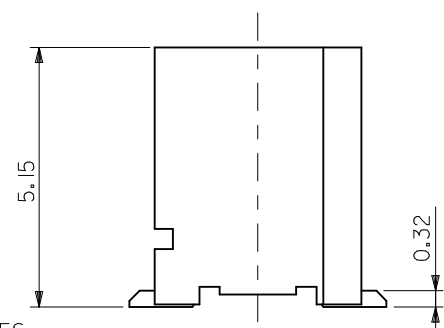
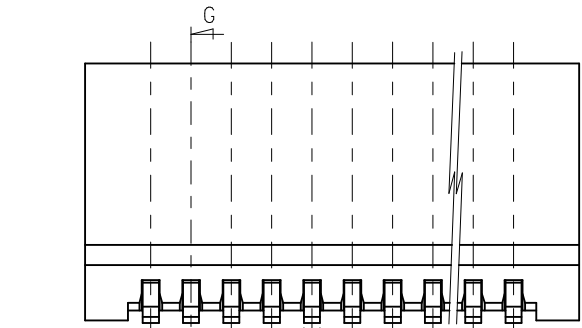
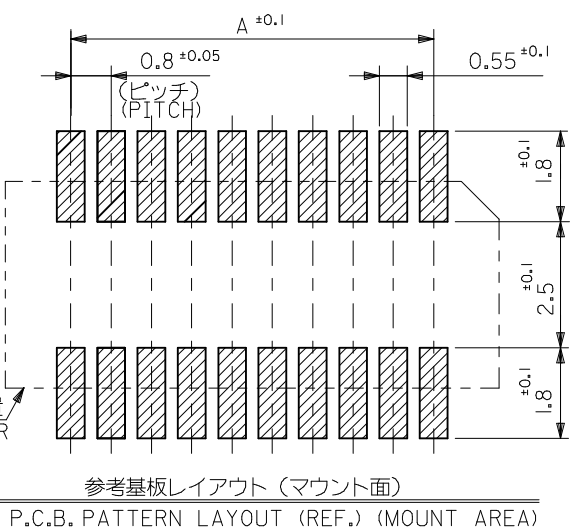
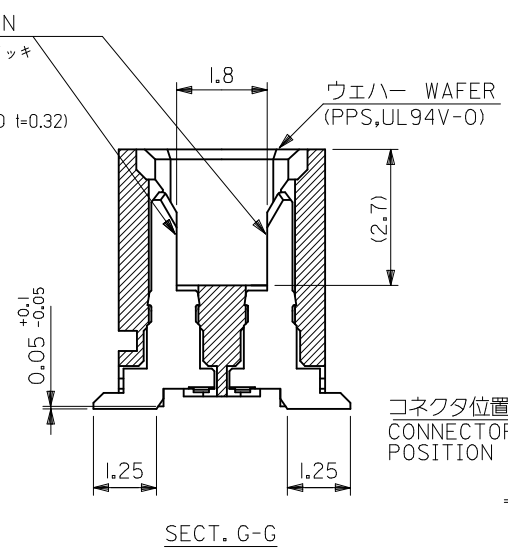
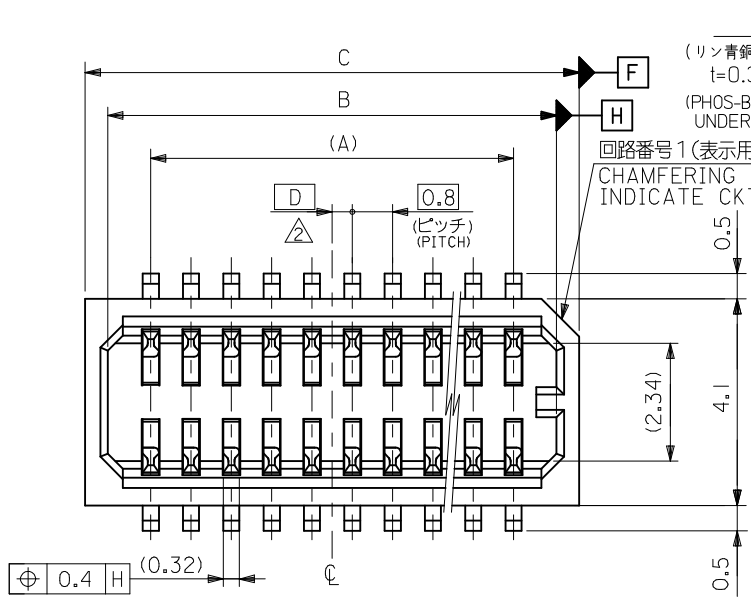

注記 NOTES

1. 嵌合相手 : 52465, 52588 シリーズ
MATES WITH : 52465, 52588 SERIES
2. ウェハーの ϕ から隣接するピンの ϕ 迄の位置を示す。
SHOW POSITION FROM ϕ OF WAFER TO ϕ OF ADJACENT PINS.
3. 本製品は 53364-**-27 の鉛フリー品である。
THIS PRODUCT IS LEAD FREE OF 53364-**-27.

0.4	17.8	16.9	15.2	53364-4029	40
0.4	16.2	15.3	13.6	53364-3629	36
0.8	13.8	12.9	11.2	53364-3029	30
0.4	13.0	12.1	10.4	53364-2829	28
0.4	9.8	8.9	7.2	53364-2029	20
0.8	9.0	8.1	6.4	53364-1829	18
0.4	6.6	5.7	4.0	53364-1229	12
0.8	5.8	4.9	3.2	53364-1029	10
D	C	B	A	MATERIAL. NO.	極数 CKT.

トレードマーク TRADE MARK

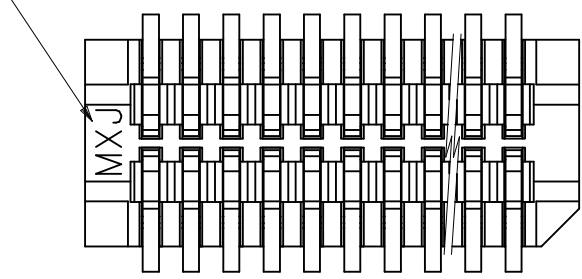

REVISED EC NO: J2009-1121 DRWN: MAKURAA 2008/12/15 CHKD: T. HARUYAMA 2008/12/15 APPR: NUKITA 2009/01/13	DESCRIPTION	GENERAL TOLERANCES (UNLESS SPECIFIED)		DIMENSION STYLE MM ONLY		SCALE ---		DESIGN UNITS METRIC		THIRD ANGLE PROJECTION		
		10 UNDER	±0.2	DRAWN BY M. NINOMIYA		DATE '03/12/11		TITLE 0.8 BOARD TO BOARD CONN. WAFER ASSY ST. SMT -LEAD FREE-				
		10 OVER 30 UNDER	±0.25	CHECKED BY K. TOJO		DATE '03/12/11		MOLEX INCORPORATED DOCUMENT NO. SD-53364-003 SHEET NO. 1 OF 2				
		30 OVER	±0.3	APPROVED BY M. SASAO		DATE '03/12/11						
REV	C	ANGULAR	±3 °	MATERIAL NO.		SEE TABLE		THIS DRAWING CONTAINS INFORMATION THAT IS PROPRIETARY TO MOLEX INCORPORATED AND SHOULD NOT BE USED WITHOUT WRITTEN PERMISSION				
		DRAFT WHERE APPLICABLE MUST REMAIN WITHIN DIMENSIONS		SIZE A3								

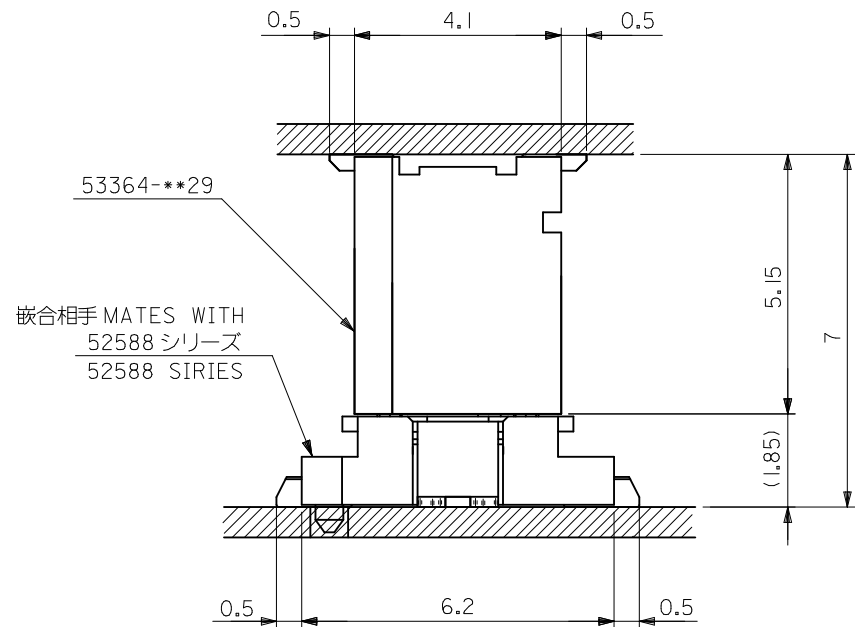
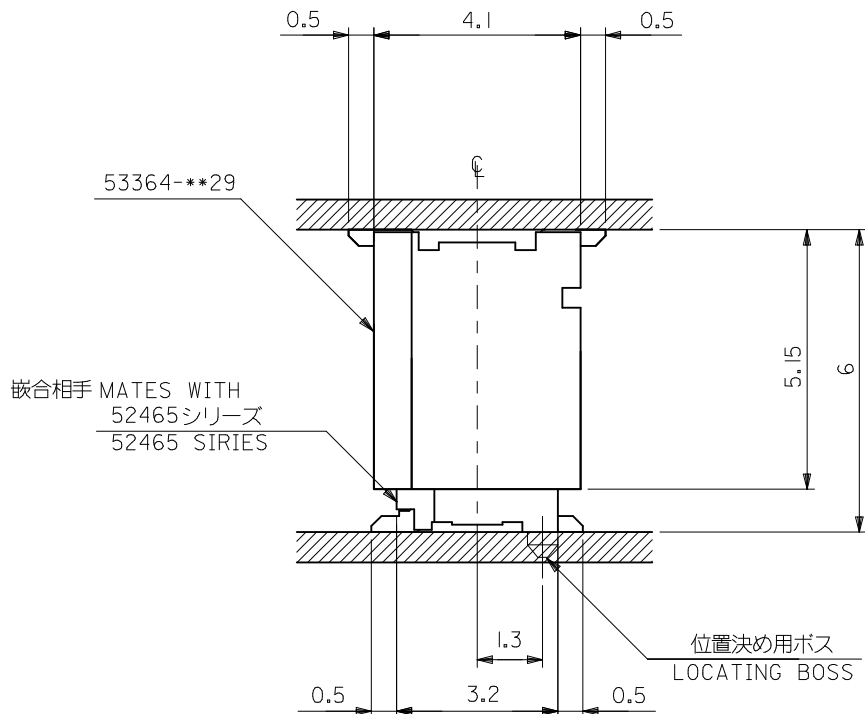

嵌合状態図 (参考)
MATED DRAWING (REF.)

REVISED EC NO: J2009-1121 DRWN: KAKURAA 2008/12/15 CHKD: T. HARUYAMA 2008/12/15 APPR: NUKITA 2009/01/13	GENERAL TOLERANCES (UNLESS SPECIFIED)		DIMENSION STYLE MM ONLY	SCALE ---	DESIGN UNITS METRIC	THIRD ANGLE PROJECTION
	10 UNDER	± ---	DRAWN BY M. NINOMIYA	DATE '03/12/11	TITLE 0.8 BOARD TO BOARD CONN. WAFER ASSY ST. SMT -LEAD FREE-	
	10 OVER 30 UNDER	± ---	CHECKED BY K. TOJO	DATE '03/12/11		
	30 OVER	± ---	APPROVED BY M. SASAO	DATE '03/12/11	MOLEX INCORPORATED	
ANGULAR	± --- °	MATERIAL NO. SEE SHEET 1	DOCUMENT NO. SD-53364-003	SHEET NO. 2 OF 2		
	DRAFT WHERE APPLICABLE MUST REMAIN WITHIN DIMENSIONS		THIS DRAWING CONTAINS INFORMATION THAT IS PROPRIETARY TO MOLEX INCORPORATED AND SHOULD NOT BE USED WITHOUT WRITTEN PERMISSION			



Компания «ЭлектроПласт» предлагает заключение долгосрочных отношений при поставках импортных электронных компонентов на взаимовыгодных условиях!

Наши преимущества:

- Оперативные поставки широкого спектра электронных компонентов отечественного и импортного производства напрямую от производителей и с крупнейших мировых складов;
- Поставка более 17-ти миллионов наименований электронных компонентов;
- Поставка сложных, дефицитных, либо снятых с производства позиций;
- Оперативные сроки поставки под заказ (от 5 рабочих дней);
- Экспресс доставка в любую точку России;
- Техническая поддержка проекта, помощь в подборе аналогов, поставка прототипов;
- Система менеджмента качества сертифицирована по Международному стандарту ISO 9001;
- Лицензия ФСБ на осуществление работ с использованием сведений, составляющих государственную тайну;
- Поставка специализированных компонентов (Xilinx, Altera, Analog Devices, Intersil, Interpoint, Microsemi, Aeroflex, Peregrine, Syfer, Eurofarad, Texas Instrument, Miteq, Cobham, E2V, MA-COM, Hittite, Mini-Circuits, General Dynamics и др.);

Помимо этого, одним из направлений компании «ЭлектроПласт» является направление «Источники питания». Мы предлагаем Вам помощь Конструкторского отдела:

- Подбор оптимального решения, техническое обоснование при выборе компонента;
- Подбор аналогов;
- Консультации по применению компонента;
- Поставка образцов и прототипов;
- Техническая поддержка проекта;
- Защита от снятия компонента с производства.



Как с нами связаться

Телефон: 8 (812) 309 58 32 (многоканальный)

Факс: 8 (812) 320-02-42

Электронная почта: org@eplast1.ru

Адрес: 198099, г. Санкт-Петербург, ул. Калинина, дом 2, корпус 4, литера А.