

## Three Channel, Three Level, High Speed Ultrasound Driver IC

### Features

- ▶ Advanced CMOS technology
- ▶ 4.5 to 12.5V power supply voltage
- ▶ 2.0A output source and sink current
- ▶ 6.5ns rise and fall time with 1.0nF load
- ▶ 10ns propagation delay
- ▶ ±2ns matched delay times
- ▶ 12 matched channels
- ▶ 1.8 to 3.3V CMOS logic interface
- ▶ Smart logic threshold
- ▶ Low inductance package

### Applications

- ▶ Medical ultrasound imaging
- ▶ Piezoelectric transducer drivers
- ▶ Metal flaw detection
- ▶ Non-Destructive Testing (NDT)

### General Description

The Supertex MD1716, paired with the Supertex TC8020, forms a three channel, three level, high voltage, high speed, transmit pulser chip set. The chip set is designed for medical ultrasound imaging applications but can also be used for metal flaw detection, Non-Destructive Testing (NDT), and piezoelectric transducer drivers.

The MD1716 is a three channel logic controller circuit with 12 low impedance MOSFET gate drivers. There are three sets of control logic inputs, one each for channels A, B and C. Each channel consists of two pairs of MOSFET gate drivers. These drivers are designed to match the gate driving requirements of the Supertex TC8020.

The TC8020 is the high voltage output stage of the pulser. It consists of six pairs of MOSFETs. Each pair has both an N- and P-channel MOSFET. They are designed to have the same impedance and can provide typical peak currents of ±3.5 amps.

### Typical Application Circuit

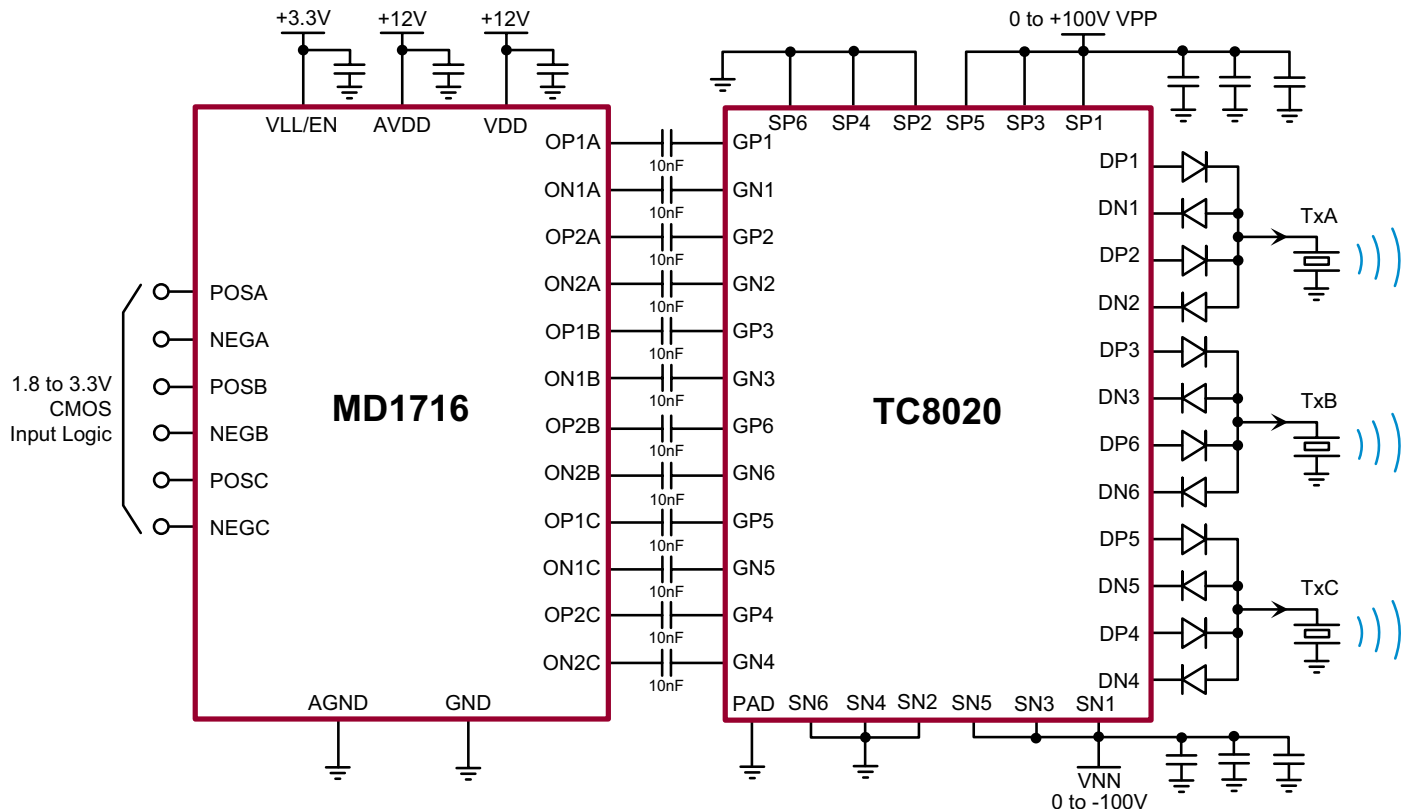

## Ordering Information

Device	Package Option
	<b>40-Lead QFN</b> 6.00x6.00mm body 1.00mm height (max) 0.50mm pitch
MD1716	MD1716K6-G



-G indicates package is RoHS compliant ('Green')

## Absolute Maximum Ratings

Parameter	Value
GND and AGND, Ground	0V
V <sub>LL</sub> logic input pin	-0.5V to +5.5V
AV <sub>DD</sub> 1, V <sub>DD</sub> 1, positive gate drive supply	-0.5V to +14.5V
V <sub>DD</sub> 2, positive gate drive supply	-0.5V to +14.5V
Storage temperature	-65°C to 150°C
Power dissipation	1.3W

Absolute Maximum Ratings are those values beyond which damage to the device may occur. Functional operation under these conditions is not implied. Continuous operation of the device at the absolute rating level may affect device reliability. All voltages are referenced to device ground.

\* 1.0oz 4-layer 3x4" PCB

## Pin Configuration

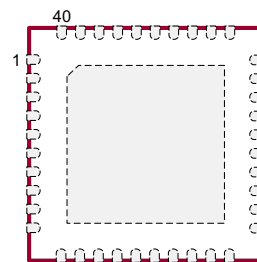

40-Lead QFN (K6)  
(top view)

## Package Marking



L = Lot Number  
 YY = Year Sealed  
 WW = Week Sealed  
 A = Assembler ID  
 C = Country of Origin  
 — = "Green" Packaging

Package may or may not include the following marks: Si or

40-Lead QFN (K6)

## Operating Supply Voltages

Sym	Parameter	Min	Typ	Max	Units	Conditions
V <sub>LL</sub>	Logic supply	1.8	3.3	3.6	V	---
AV <sub>DD</sub>	Positive analog supply	4.75	-	12.9	V	AV <sub>DD</sub> ≥ V <sub>DD</sub>
V <sub>DD</sub>	Positive gate drive supply	4.75	-	12.9	V	---

## Operating Supply Current

(Over operating conditions unless otherwise specified, V<sub>LL</sub> = 3.3V, AV<sub>DD</sub> = V<sub>DD</sub> = +12V, T<sub>A</sub> = 25°C)

Sym	Parameter	Min	Typ	Max	Units	Conditions
I <sub>VLL</sub>	Logic reference current	-	10	-	µA	V <sub>LL</sub> = 3.3V
I <sub>AVDDQ</sub>	AV <sub>DD</sub> power down current	-	400	-	µA	EN = 0, all inputs Low.
I <sub>VDDQ</sub>	V <sub>DD</sub> power down current	-	50	100		
I <sub>AVDDEN</sub>	AV <sub>DD</sub> power up current	-	2.0	3.0	mA	EN = 1, all inputs Low.
I <sub>VDDEN</sub>	V <sub>DD</sub> power up current	-	0.7	1.0		
I <sub>AVDDCW</sub>	AV <sub>DD</sub> CW 5.0MHz current	-	10	-	mA	All channels on at 5.0MHz, No load. V <sub>DD</sub> = 5.0V
I <sub>VDDCW</sub>	V <sub>DD</sub> CW 5.0MHz current	-	33	-		

## AC Electrical Characteristics

(Over operating conditions unless otherwise specified,  $V_{LL} = 3.3V$ ,  $V_{DD} = V_{DD} = +12V$ ,  $T_A = 25^\circ C$ )

Sym	Parameter	Min	Typ	Max	Units	Conditions
$t_{irf}$	Input rise & fall time	-	-	10	ns	Logic input edge speed requirement
$t_r$	Output rise time	-	6.5	-	ns	1.0nF load, see timing diagram, input signal rise/fall time 2.0ns
$t_f$	Output fall time	-	6.5	-	ns	
$t_{dr}$	Output rise delay	-	10	-	ns	1.0nF load, see timing diagram, input signal rise/fall time 2.0ns
$t_{df}$	Output fall delay	-	10	-	ns	
$ t_r - t_f $	Rise and fall time matching	-	1.0	-	-	For each channel
$ t_{dr} - t_{df} $	Propagation delay matching	-	1.0	-	-	
$t_{dm}$	Delay time matching	-	$\pm 2.0$	-	ns	Channel to Channel and Device to Device
$\Delta t_j$	Output jitter	-	20	-	ps	$V_{DD} = 10V$
$t_{EN\_ON}$	IC enable time	-	-	50	$\mu s$	---
$t_{EN\_OFF}$	IC disable time	-	-	2.0	$\mu s$	---

## P-Channel Gate Driver Outputs

Sym	Parameter	Min	Typ	Max	Units	Conditions
$R_{SINK}$	Output sink resistance	-	-	6.0	$\Omega$	$I_{SINK} = 100mA$
$R_{SOURCE}$	Output source resistance	-	-	6.0	$\Omega$	$I_{SOURCE} = 100mA$
$I_{SINK}$	Peak output sink current	1.7	2.0	-	A	---
$I_{SOURCE}$	Peak output source current	1.7	2.0	-	A	---

## N-Channel Gate Driver Outputs

Sym	Parameter	Min	Typ	Max	Units	Conditions
$R_{SINK}$	Output sink resistance	-	3.0	6.0	$\Omega$	$I_{SINK} = 100mA$
$R_{SOURCE}$	Output source resistance	-	4.0	6.0	$\Omega$	$I_{SOURCE} = 100mA$
$I_{SINK}$	Peak output sink current	1.7	2.0	-	A	---
$I_{SOURCE}$	Peak output source current	1.7	2.0	-	A	---

## Logic Inputs

Sym	Parameter	Min	Typ	Max	Units	Conditions
$V_{ENL}$	Chip disable low voltage	0	-	0.3	V	VLL/EN is a dual function pin
$V_{IH}$	Input logic high voltage	$0.8V_{LL}$	-	$V_{LL}$	V	---
$V_{IL}$	Input logic low voltage	0	-	$0.2V_{LL}$	V	---
$I_{IH}$	Input logic high current	-	-	1.0	$\mu A$	---
$I_{IL}$	Input logic low current	-1.0	-	-	$\mu A$	---

Truth Table

EN	Logic Inputs A		SP1 to DP1	SN1 to DN1	SP2 to DP2	SN2 to DN2
	POSA	NEGA				
1	0	0	OFF	OFF	ON	ON
1	0	1	OFF	ON	OFF	OFF
1	1	0	ON	OFF	OFF	OFF
1	1	1	OFF	OFF	OFF	OFF
EN	Logic Inputs B		SP3 to DP3	SN3 to DN3	SP6 to DP6	SN6 to DN6
	POSB	NEGB				
1	0	0	OFF	OFF	ON	ON
1	0	1	OFF	ON	OFF	OFF
1	1	0	ON	OFF	OFF	OFF
1	1	1	OFF	OFF	OFF	OFF
EN	Logic Inputs C		SP5 to DP5	SN5 to DN5	SP4 to DP4	SN4 to DN4
	POSC	NEGC				
1	0	0	OFF	OFF	ON	ON
1	0	1	OFF	ON	OFF	OFF
1	1	0	ON	OFF	OFF	OFF
1	1	1	OFF	OFF	OFF	OFF
0	X	X	OFF	OFF	OFF	OFF
0→1	0	0	EN transitions from low to high or high to low should occur at all logic inputs low.			
1→0	0	0				

Timing Diagram

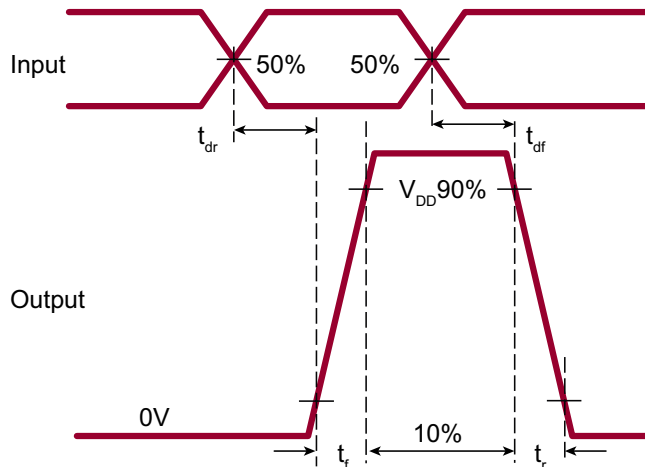

Detail Circuit

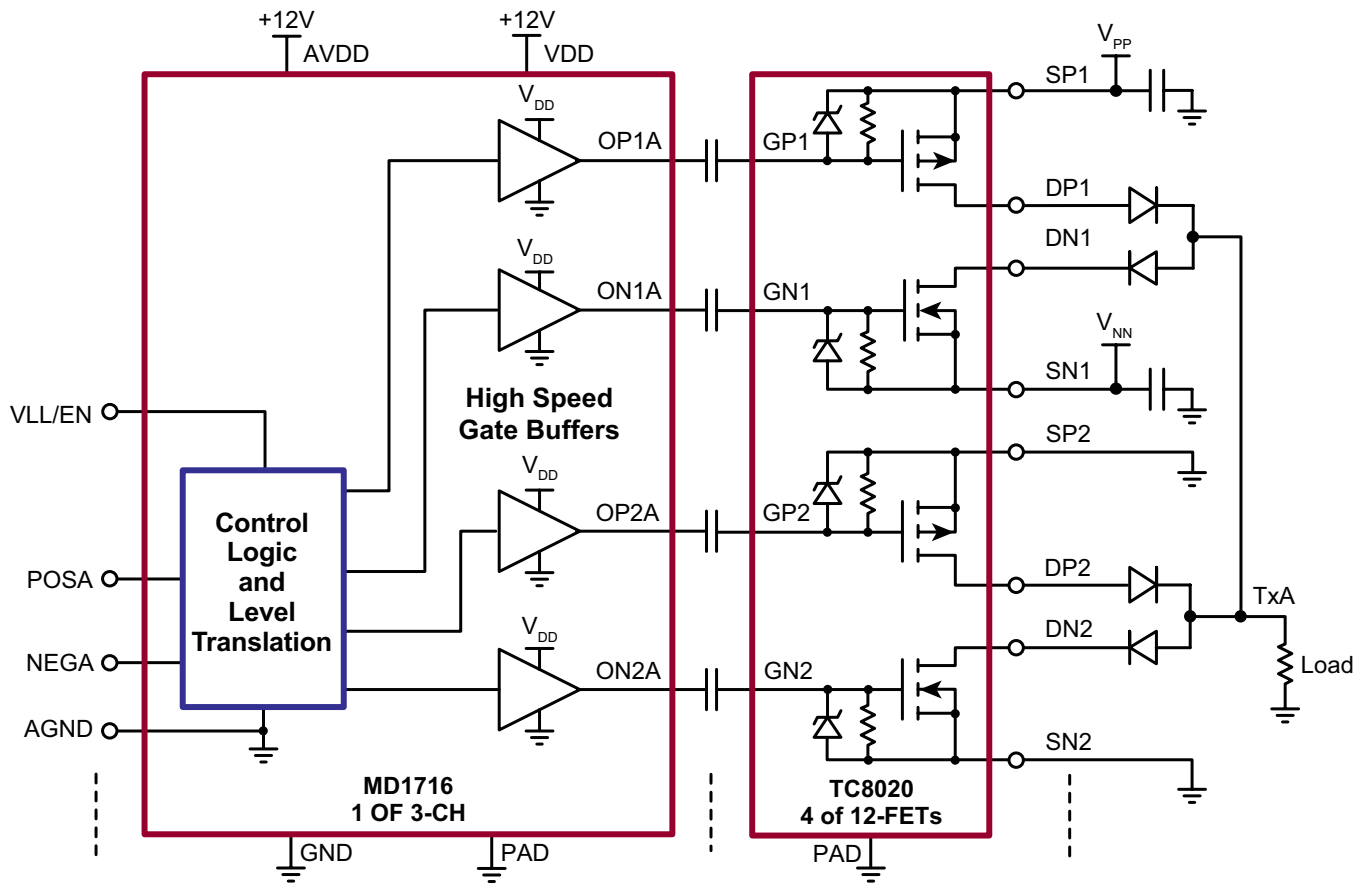

Circuit Pin Layout

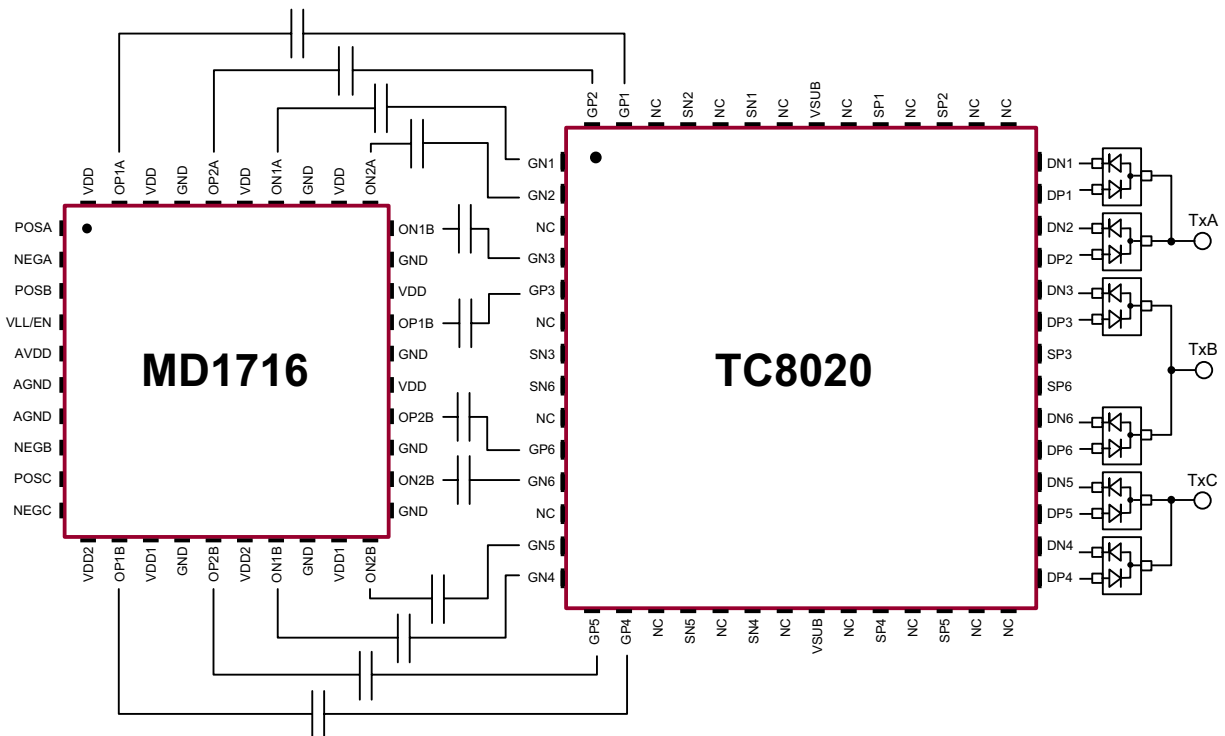

## Pin Description

Pin #	Name	Description
1	POSA	POS input logic control for channel A. See logic truth table for details.
2	NEGA	NEG input logic control for channel A. See logic truth table for details.
3	POSB	POS input logic control for channel B. See logic truth table for details.
4	VLL/EN	Logic Hi reference voltage and chip enable input.
5	AVDD	Positive supply voltage of analog circuitry. AVDD should be same or higher potential than the VDD.
6	AGND	Digital ground, and connection of IC substrate.
7	AGND	
8	NEGB	NEG input logic control for channel B. See logic truth table for details.
9	POSC	POS input logic control for channel C. See logic truth table for details.
10	NEGC	NEG input logic control for channel C. See logic truth table for details.
11	VDD	Positive supply voltage of the gate drivers for the output stage in A, B and C channels.
12	OP2C	Damping P-Channel gate drivers for channel C.
13	VDD	Positive supply voltage of the gate drivers for the output stage in A, B and C channels.
14	GND	Power Ground.
15	OP1C	High Voltage Output P-Channel gate drivers for channel C.
16	VDD	Positive supply voltage of the gate drivers for the output stage in A, B and C channels.
17	ON2C	Damping N-Channel gate drivers for channel C.
18	GND	Power Ground.
19	VDD	Positive supply voltage of the gate drivers for the output stage in A, B and C channels.
20	ON1C	High Voltage Output N-Channel gate drivers for channel C.
21	GND	Power Ground.
22	ON2B	Damping N-Channel gate drivers for channel B.
23	GND	Power Ground.
24	OP2B	Damping P-Channel gate drivers for channel B.
25	VDD	Positive supply voltage of the gate drivers for the output stage in A, B and C channels.
26	GND	Power Ground.
27	OP1B	High Voltage Output P-Channel gate drivers for channel B.
28	VDD	Positive supply voltage of the gate drivers for the output stage in A, B and C channels.
29	GND	Power Ground.
30	ON1B	High Voltage Output N-Channel gate drivers for channel B.
31	ON2A	Damping N-Channel gate drivers for channel A.
32	VDD	Positive supply voltage of the gate drivers for the output stage in A, B and C channels.
33	GND	Power Ground.

**Pin Description** *(cont.)*

Pin #	Name	Description
34	ON1A	High Voltage Output N-Channel gate drivers for channel A.
35	VDD	Positive supply voltage of the gate drivers for the output stage in A, B and C channels.
36	OP2A	Damping P-Channel gate drivers for channel A.
37	GND	Power Ground.
38	VDD	Positive supply voltage of the gate drivers for the output stage in A, B and C channels.
39	OP1A	High Voltage Output P-Channel gate drivers for channel A.
40	VDD	Positive supply voltage of the gate drivers for the output stage in A, B and C channels.
Center Pad	Thermal pad	IC substrate, must connect to GND externally.

# 40-Lead QFN Package Outline (K6)

6.00x6.00mm body, 1.00mm height (max), 0.50mm pitch

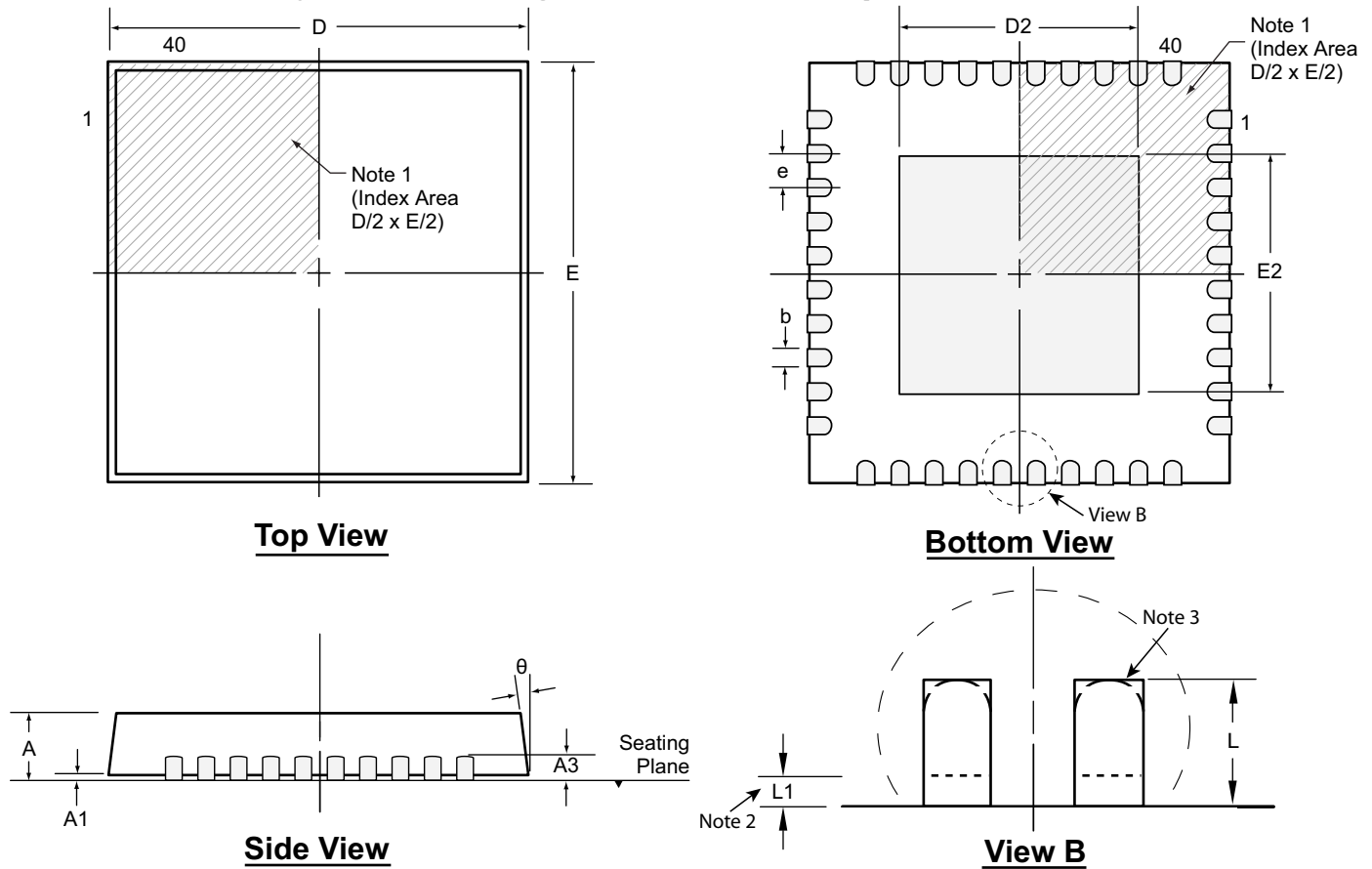

**Notes:**

1. A Pin 1 identifier must be located in the index area indicated. The Pin 1 identifier can be: a molded mark/identifier; an embedded metal marker; or a printed indicator.
2. Depending on the method of manufacturing, a maximum of 0.15mm pullback (L1) may be present.
3. The inner tip of the lead may be either rounded or square.

Symbol	A	A1	A3	b	D	D2	E	E2	e	L	L1	θ°	
Dimension (mm)	MIN	0.80	0.00	0.20 REF	0.18	5.85*	1.05	5.85*	1.05	0.50 BSC	0.30 <sup>†</sup>	0.00	0
	NOM	0.90	0.02		0.25	6.00	-	6.00	-		0.40 <sup>†</sup>	-	-
	MAX	1.00	0.05		0.30	6.15*	4.45	6.15*	4.45		0.50 <sup>†</sup>	0.15	14

JEDEC Registration MO-220, Variation VJJD-6, Issue K, June 2006.

\* This dimension is not specified in the JEDEC drawing.

† This dimension differs from the JEDEC drawing.

Drawings not to scale.

Supertex Doc. #: DSPD-40QFNK66X6P050, Version C041009.

(The package drawing(s) in this data sheet may not reflect the most current specifications. For the latest package outline information go to <http://www.supertex.com/packaging.html>.)

Supertex inc. does not recommend the use of its products in life support applications, and will not knowingly sell them for use in such applications unless it receives an adequate "product liability indemnification insurance agreement." Supertex inc. does not assume responsibility for use of devices described, and limits its liability to the replacement of the devices determined defective due to workmanship. No responsibility is assumed for possible omissions and inaccuracies. Circuitry and specifications are subject to change without notice. For the latest product specifications refer to the Supertex inc. (website: <http://www.supertex.com>)





Компания «ЭлектроПласт» предлагает заключение долгосрочных отношений при поставках импортных электронных компонентов на взаимовыгодных условиях!

Наши преимущества:

- Оперативные поставки широкого спектра электронных компонентов отечественного и импортного производства напрямую от производителей и с крупнейших мировых складов;
- Поставка более 17-ти миллионов наименований электронных компонентов;
- Поставка сложных, дефицитных, либо снятых с производства позиций;
- Оперативные сроки поставки под заказ (от 5 рабочих дней);
- Экспресс доставка в любую точку России;
- Техническая поддержка проекта, помощь в подборе аналогов, поставка прототипов;
- Система менеджмента качества сертифицирована по Международному стандарту ISO 9001;
- Лицензия ФСБ на осуществление работ с использованием сведений, составляющих государственную тайну;
- Поставка специализированных компонентов (Xilinx, Altera, Analog Devices, Intersil, Interpoint, Microsemi, Aeroflex, Peregrine, Syfer, Eurofarad, Texas Instrument, Miteq, Cobham, E2V, MA-COM, Hittite, Mini-Circuits, General Dynamics и др.);

Помимо этого, одним из направлений компании «ЭлектроПласт» является направление «Источники питания». Мы предлагаем Вам помощь Конструкторского отдела:

- Подбор оптимального решения, техническое обоснование при выборе компонента;
- Подбор аналогов;
- Консультации по применению компонента;
- Поставка образцов и прототипов;
- Техническая поддержка проекта;
- Защита от снятия компонента с производства.



#### Как с нами связаться

**Телефон:** 8 (812) 309 58 32 (многоканальный)

**Факс:** 8 (812) 320-02-42

**Электронная почта:** [org@eplast1.ru](mailto:org@eplast1.ru)

**Адрес:** 198099, г. Санкт-Петербург, ул. Калинина, дом 2, корпус 4, литера А.