

Detector Switch General-purpose Type

SPPB Series



A wide variety of detector switches available for various Digital AV devices.

- Detector
- Push
- Slide
- Rotary
- Encoders
- Power



Typical Specifications

Items		Specifications
Rating (max.) (min.) (Resistive load)		0.1A 30V DC/50μA 3V DC
Contact resistance (Initial /After operating life)		1 max./2 max.
Operating force		0.35N max.
Operating life	Without load	50,000cycles
	With load	50,000cycles(0.1A 30V DC)

Product Line

Poles	Positions	Operating part shape	Operating direction	Terminal type	Packaging style	Minimum order unit (pcs)	Product No.	Drawing No.	
1	1	Push	Horizontal	Lead	Bulk	10,000	SPPB110300	1	
							SPPB120200	2	
							SPPB310400	7	
		Actuator A	Horizontal	Lead		Bulk	5,000	SPPB320100	8
								SPPB1A0100	3
								SPPB1A0101	4
		Actuator C	Horizontal	Lead		Bulk	5,000	SPPB2A0100	5
								SPPB2A0101	6
								SPPB512300	9
		Push	Vertical	For PC board (Dip)	Bulk	20,000	SPPB610400	13	
							SPPB620300	14	
							SPPB5A0100	10	
		Actuator A	Horizontal	For PC board (Dip)		Bulk	5,000	SPPB6A0100	15
								SPPB6A0400	16
								SPPB530701	11
		Push	Vertical	For PC board (Reflow)		Taping	6000	SPPB530601	12
								SPPB630101	17
								SPPB640201	18
Push	Horizontal	For PC board (Reflow)	Taping	2400	SPPB630101		17		
					SPPB640201		18		
					SPPB640201		18		

Taping Specifications (Taping Packaging)

Reel Size Unit:mm

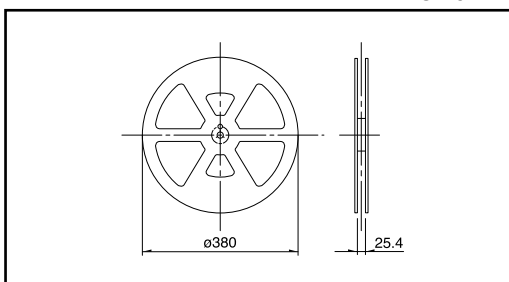

Product No.	Number of packages(pcs.)			Tape width (mm)
	1 reel	1 case /Japan	1 case /export packing	
SPPB530701	1,500	3,000	6,000	24
SPPB530601	600	1,200	2,400	
SPPB630601 SPPB640201	1,300	2,600	5,200	

Note

Please place purchase orders per minimum order unit(integer).

Detector

Push

Slide

Rotary





Encoders

Power

Dual-in-line
 Package Type

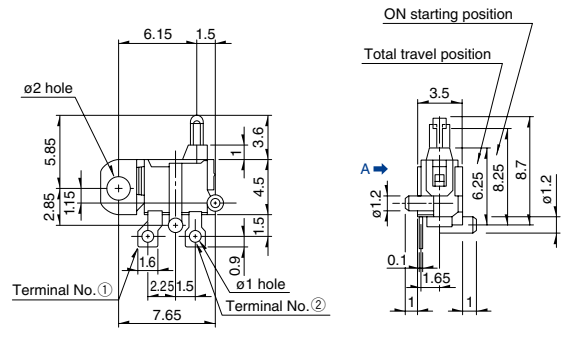
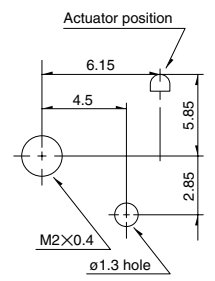
TACT Switch™

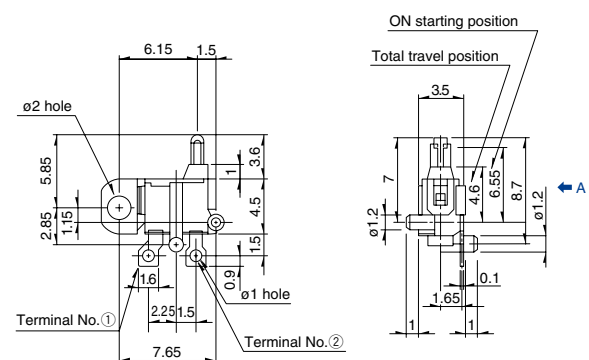
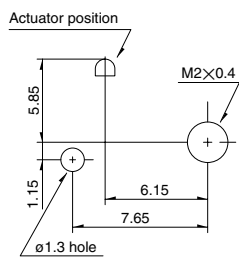
Custom-
 Products

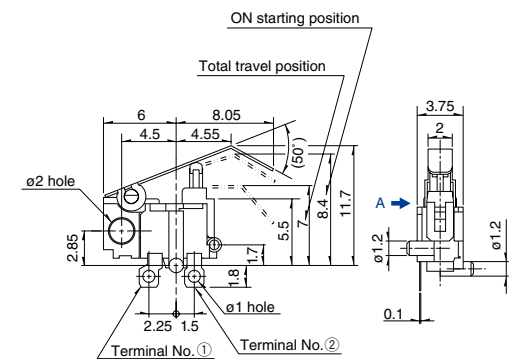
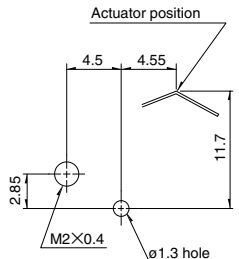
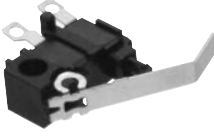
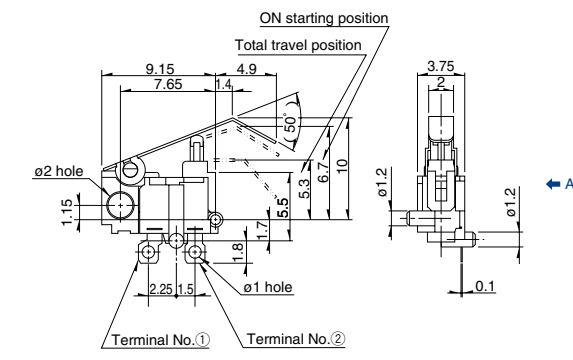
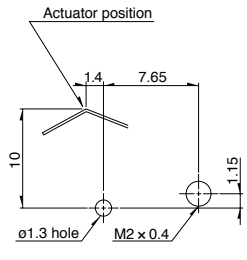
Dimensions		Unit:mm	
No.	Photo	Style	PC board mounting hole dimensions (Viewed from direction A)
1			
2			
3			
4			

Dimensions

Unit:mm

Detector

Push

Slide

Rotary

Encoders

Power

Dual-in-line
 Package Type

TACT Switch™

Custom-
 Products

No.	Photo	Style	PC board mounting hole dimensions (Viewed from direction A)
5		<p>Actuator C</p>	
6		<p>Actuator C</p>	
7		<p>Push</p>	
8		<p>Push</p>	

Dimensions

Unit:mm

No.	Photo	Style	PC board mounting hole and land dimensions (Viewed from direction A)
9	Push		
10	Actuator A		
11	Push		
12	Push		

Detector

Push

Slide

Rotary

Encoders

Power

Dual-in-line
 Package Type

TACT Switch™

Custom-
 Products

Dimensions

Unit:mm

No.	Photo	Style	PC board mounting hole and land dimensions (Viewed from direction A)
13	<p>Push</p>		
14	<p>Push</p>		
15	<p>Actuator A</p>		
16	<p>Actuator A</p>		

Dimensions

Unit:mm

No.	Photo	Style	PC board mounting hole and land dimensions (Viewed from direction A)
17			
18			

Detector

Push

Slide

Rotary

Encoders

Power

Dual-in-line
Package Type

TACT Switch™

Custom-
Products

Circuit Diagram (Viewed from Direction A)

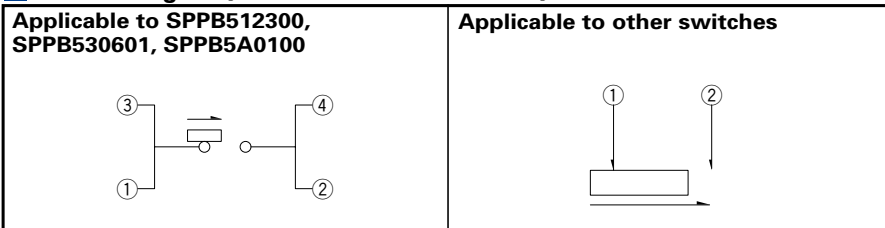

List of Varieties (General-purpose Type)

Series	General-purpose Type								
	SPPB	SPVE	SPPW8	SPVM	SPVR	SPVF	SSCU	SSCT	
Photo									
Operation type	 								
Operating temperature range	-40 to +85	-10 to +60		-40 to +85		-10 to +60	-40 to +85		
Rating (max.) (Resistive load)	0.1A 30V DC			1mA 5V DC			0.1A 12V DC		
Rating (min.) (Resistive load)	50μA 3V DC		100μA 3V DC	50μA 3V DC	100μA 3V DC	50μA 3V DC			
Electrical performance	Initial contact resistance	1 max.	500m max.	1 max.	2 max.	3 max.	500m max.	70m max. 20m max.	
	Insulation resistance	100M min. 100V DC						100M min. 250V DC	
	Voltage proof	100V AC for 1 minute						250V AC for 1 minute	
Mechanical performance	Terminal strength	3N for 1 minute	0.5N for 1 minute	3N for 1 minute	1N for 1 minute	0.5N for 1 minute	3N for 30s	3N for 1 minute	
	Actuator strength	10N	5N	10N	5N	2N	1N	5N 10N	
Durability	Operating life without Load	50,000cycles 2 max.	50,000cycles 1 max.	100,000cycles 2 max.	50,000cycles 5 max.		100,000cycles 1 max.	10,000cycles 100m max. 40m max.	
	Operating life with Load	(0.1A 30V DC) 50,000cycles 2 max.	(0.1A 30V DC) 50,000cycles 1 max.	(0.1A 30V DC) 100,000cycles 2 max.	(1mA 5V DC) 50,000cycles 5 max.		(1mA 5V DC) 100,000cycles 1 max.	(0.1A 12V DC) 10,000cycles 150m max. 60m max.	
Environmental performance	Cold	-20 ± 2 for 96h					-40 ± 2 for 96h	-20 ± 2 for 96h	
	Dry heat	85 ± 2 for 96h							
	Damp heat	40 ± 2 , 90 to 95%RH for 96h							
Dimensions (mm)	W	6.3	3.4	5	2.8	3.6	9	11 12.5	
	D	3		4	3.5	4.2	3.5	5.8 5	
	H	4.9	2.3		1.5	1.2	4.5	7 11.5	
Soldering	Manual soldering	300 ± 5 , 5s max.	350 ± 5 , 3s max.				300 ± 10 , 3 ± 1s	350 ± 5 , 3s max.	
	Dip soldering	260 ± 5 , 5 ± 1s		255 ± 5 , 5 ± 1s			245 ± 5 , 5 ± 1s	260 ± 5 , 5 ± 1s	
	Reflow soldering	Please see P.79							
Number of poles	1					1.2	1		
Operation force	0.35N max.	0.3N max.		0.4N max.	0.35N max.	0.3N max.	0.5N max.	0.7 ± 0.3N	
Page	28	34	36	38	40	41	44	45	

Detector

Push

Slide

Rotary

Encoders

Power

Dual-in-line Package Type

TACT Switch™

Custom-Products

Detector Switches Soldering Conditions79

Detector Switches Cautions80

Soldering Conditions

Example of Reflow Soldering Condition

1. Heating method: Double heating method with infrared heater.
2. Temperature measurement: Thermocouple 0.1 to 0.2 CA (K) or CC (T) at soldering portion (copper foil surface). A heat resisting tape should be used for fixed measurement.
3. Temperature profile

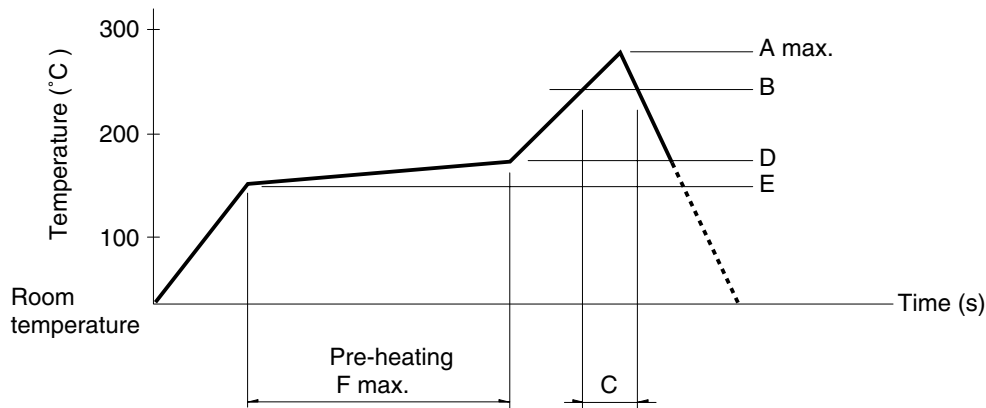

Detector

Push

Slide

Rotary

Encoders

Power

Dual-in-line
Package Type

TACT Switch™

Custom-
Products

Series(Reflow type)	A() 3s max.	B()	C(s)	D()	E()	F(s)
SPPB	250	230	40			
SPPW8		200	20			
SPVE	260	230	40	180	150	120
SPVG						
SPVL						
SPVM						
SPVN						
SPVP						
SPVR						
SPVS						
SSCM						
SPPY5						

Notes

1. The condition mentioned above is the temperature on the mounting surface of a PC board. There are cases where the PC board's temperature greatly differs from that of the switch, depending on the PC board's material, size, thickness, etc. The above-stated conditions shall also apply to switch surface temperatures.
2. Soldering conditions differ depending on reflow soldering machines. Prior verification of soldering condition is highly recommended.



Компания «ЭлектроПласт» предлагает заключение долгосрочных отношений при поставках импортных электронных компонентов на взаимовыгодных условиях!

Наши преимущества:

- Оперативные поставки широкого спектра электронных компонентов отечественного и импортного производства напрямую от производителей и с крупнейших мировых складов;
- Поставка более 17-ти миллионов наименований электронных компонентов;
- Поставка сложных, дефицитных, либо снятых с производства позиций;
- Оперативные сроки поставки под заказ (от 5 рабочих дней);
- Экспресс доставка в любую точку России;
- Техническая поддержка проекта, помощь в подборе аналогов, поставка прототипов;
- Система менеджмента качества сертифицирована по Международному стандарту ISO 9001;
- Лицензия ФСБ на осуществление работ с использованием сведений, составляющих государственную тайну;
- Поставка специализированных компонентов (Xilinx, Altera, Analog Devices, Intersil, Interpoint, Microsemi, Aeroflex, Peregrine, Syfer, Eurofarad, Texas Instrument, Miteq, Cobham, E2V, MA-COM, Hittite, Mini-Circuits, General Dynamics и др.);

Помимо этого, одним из направлений компании «ЭлектроПласт» является направление «Источники питания». Мы предлагаем Вам помощь Конструкторского отдела:

- Подбор оптимального решения, техническое обоснование при выборе компонента;
- Подбор аналогов;
- Консультации по применению компонента;
- Поставка образцов и прототипов;
- Техническая поддержка проекта;
- Защита от снятия компонента с производства.



Как с нами связаться

Телефон: 8 (812) 309 58 32 (многоканальный)

Факс: 8 (812) 320-02-42

Электронная почта: org@eplast1.ru

Адрес: 198099, г. Санкт-Петербург, ул. Калинина, дом 2, корпус 4, литера А.