

GP2AP054A00F

Proximity/Gesture Sensor with Integrated Ambient Light Sensor



■Description

GP2AP054A00F is Gesture and Proximity Sensor with Ambient Light Sensor.

Ambient light sensor detects the brightness.

Proximity sensor detects presence of object.

Gesture sensor detects the movement of a hand without touching the screen.

Three sensors integrated into 1 chip.

Small size (4.0 × 2.1 × 1.25t mm) device is available by the technology.

■Agency approvals/Compliance

1. Compliant with RoHS directive (2002/95/EC)

■Applications

1. Smartphone
2. Tablet
3. Others (Touchless switch etc.)

■Features

1. LED and ambient light sensor combined in a signal package
2. Built-in LEDs for simple optical design
3. Compact package (4.0 × 2.1 × 1.25t mm)
4. I²C output compatible
5. Proximity detection distance *1 : TYP.100mm
*1 : Kodak gray card (white side)
6. Gesture recognition : Directional hand movements detected without touching the screen
7. Illuminance output : digital 16bit output
(Minimum detectable illuminance : 0.02lx)

Notice The content of data sheet is subject to change without prior notice.

In the absence of confirmation by device specification sheets, SHARP takes no responsibility for any defects that may occur in equipment using any SHARP devices shown in catalogs, data books, etc. Contact SHARP in order to obtain the latest device specification sheets before using any SHARP device.

Sheet No.: OP14042EN

■ **Block diagram**

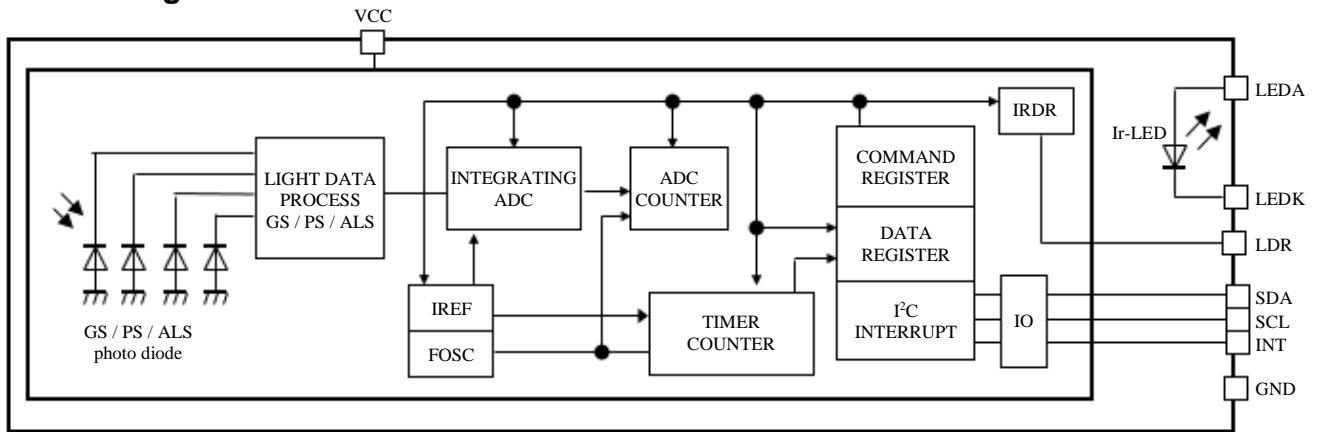

■ Outline Dimensions

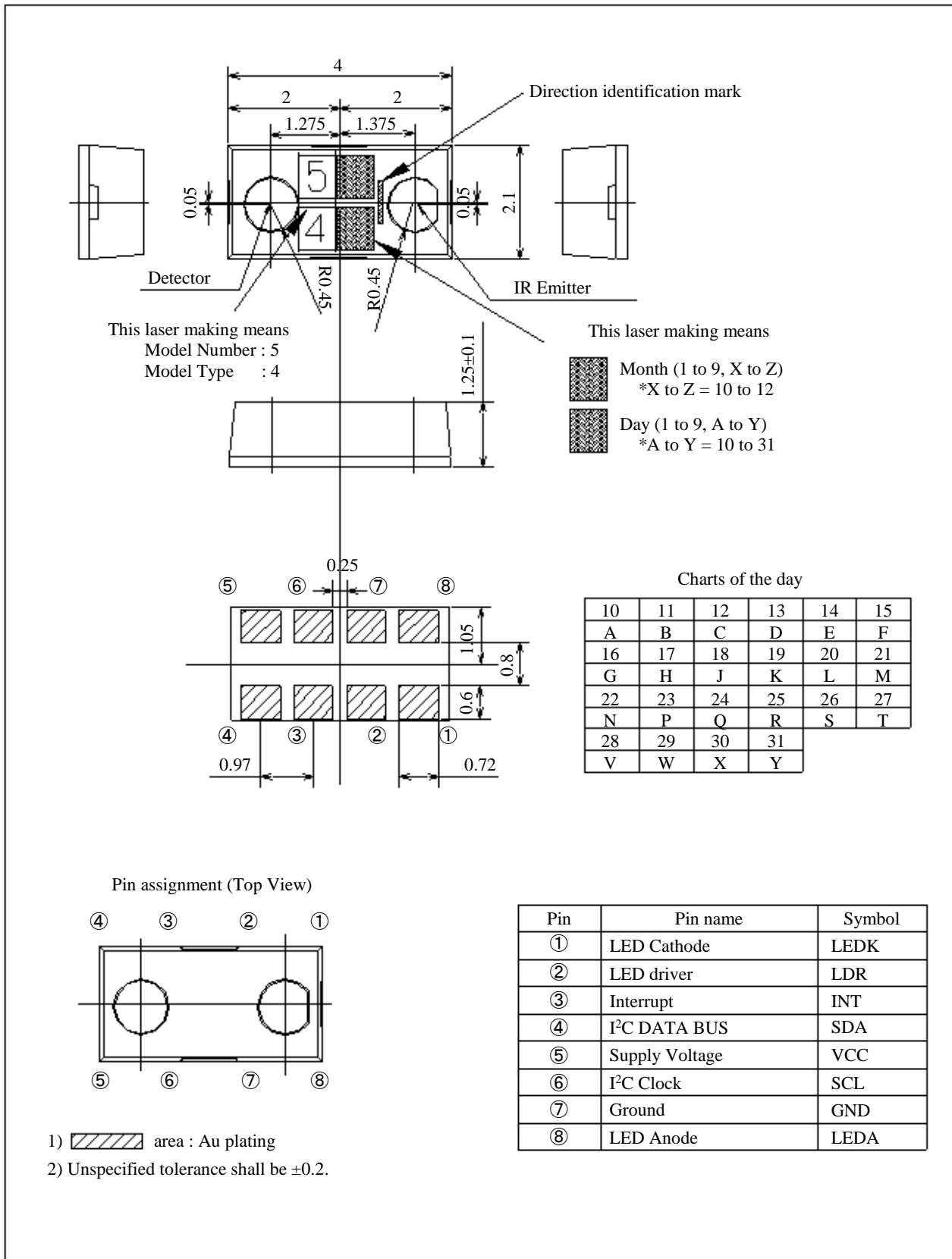

SCALE	MATERIAL	FINISH	Name	GP2AP054A00F Outline dimension									
10/1	Terminal : Cu Package : Epoxy resin	Terminal : Ni, Au											
UNIT			Drawing No.		C	Y	1	5	2	5	0	i	0
1=1/1mm													

■ Absolute Maximum Ratings

Ta=25°C (unless otherwise specified)

Parameter	Symbol	Rating	Unit	Remarks
Power supply voltage	VCC	-0.3 to 5.7	V	
LED voltage	VLED	-0.3 to 5.7	V	
I ² C voltage	VI ² C	-0.3 to 5.7	V	
Operating temperature	Topr	-30 to 85	°C	
Storage temperature	Tstg	-40 to 85	°C	
Soldering temperature	Tsol	250	°C	peak temperature duration : 10s

■ Recommended Operating Conditions

Ta=25°C (unless otherwise specified)

Parameter	Symbol	Operating condition	Unit	Remarks
Power supply voltage	VCC	2.2 to 5.5	V	
LED voltage	VLED	2.2 to 5.5	V	
I ² C voltage	VI ² C	1.7 to 5.5	V	
Operating temperature	Topr	-30 to 85	°C	
SCL, SDA input low level	VIL	-0.3 to 0.54	V	
SCL, SDA input high level	VIH	1.26 to 5.7	V	

■ Electrical and Optical Characteristics

Ta=25°C, VCC=VLED=VI²C=3.0V

(unless otherwise specified. The external circuit constants follow the recommended external circuit of page 8.)

Parameter	Symbol	Min.	Typ.	Max.	Unit	Remarks
Current consumption (GS)	ICC_GS		320	450	μA	OP[1:0]=10
Current consumption (ALS)	ICC_ALS		100	150	μA	OP[1:0]=01, RANGE_A=0000
Current consumption (Power Down)	ICC-s	—	—	8	μA	OP[3]=0
Internal Oscillator Frequency	fosc1	1.70	2.13	2.84	MHz	
I ² C clock frequency	f	1	—	400	kHz	
SDA output low level voltage	V _{OL_SDA}	0	—	0.4	V	I _{OL_SDA} =3mA
INT output low level voltage	V _{OL_INT}	0	—	0.4	V	I _{OL_INT} =3mA
ADC Conversion Time1 (GS)	Tint_G	1.4	1.9	2.4	ms	12bit ADC
ADC Conversion Time1 (ALS)	Tint_A	23	30	38.5	ms	16bit ADC
Full scale ADC code1	Data_FGS	—	—	16383	counts	
Full scale ADC code2	Data_FALS	—	—	65535	counts	
Dark count_ALS	Data_0	—	0	5	counts	at 0 lx, RES_A=01, RANGE_A=0011
ADCCODE_ALS1	Data_A1	800	1000	1200	lux	at 1000 lx, White color LED 5200K *1
Detection distance	Lon	80	100	120	mm	Detection Object : KODAK Gray Card (white side/r=0.9) *2
Typical (amount of) distance for GS operation	Dz_GS	—	100	—	mm	Z-axis direction *3
Minimum (amount of) displacement (required) for GS operation	Dxy_GS	—	120	—	mm	XY-axis direction at Dz_GS=100mm *3

Ta=25°C, VCC=VLED=VI²C=3.0V

(unless otherwise specified. The external circuit constants follow the recommended external circuit of page 8.)

Parameter	Symbol	Min.	Typ.	Max.	Unit	Remarks
LED peak wavelength	λ_{P_PS}	—	940	—	nm	
LED peak current	I_{LED4}		19	—	mA	IS[2:0]=011
	I_{LED5}		38	—	mA	IS[2:0]=100
	I_{LED6}	—	75	—	mA	IS[2:0]=101
	I_{LED7}	—	150	—	mA	IS[2:0]=110
	I_{LED8}	—	280	—	mA	IS[2:0]=111

Typical value is a reference value, there is no guarantee

*1. ALS

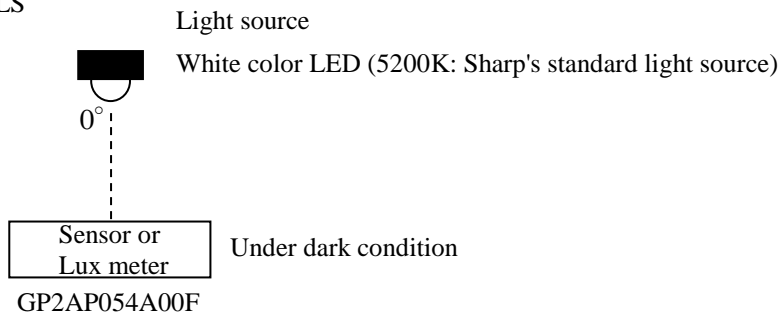

*2. Detection distance (PS part)

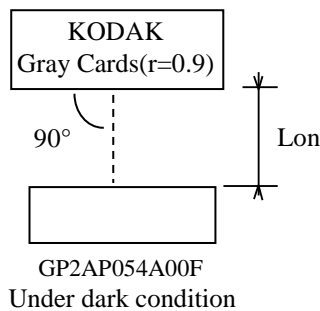

*3. Detecting distance (GS part)

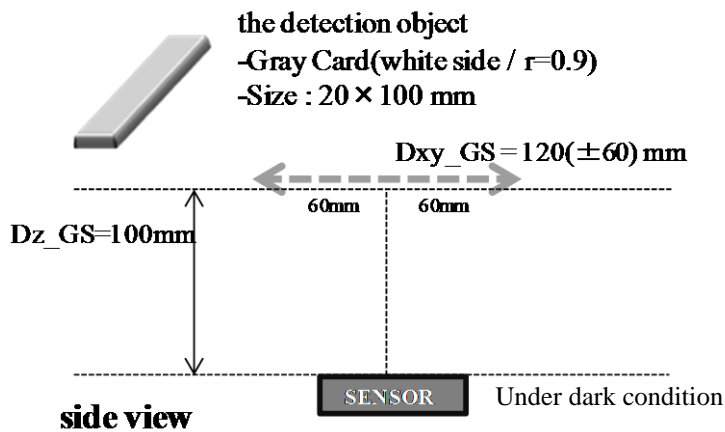

■ **Supplement**

- 1) This product is built-in photodiode.
- 2) Brominated flame retardants
Specific brominated flame retardants such as the PBB and PBDE are not used in this device at all.
- 3) This product shall not contain the following materials.
Also, the following materials shall not be used in the production process for this product.
Materials for ODS : CFCs, Halon, Carbon tetrachloride, 1,1,1-Trichloroethane (Methylchloroform)
- 4) Compliance with each regulation
 - The RoHS directive (2002/95/EC)
This product complies with the RoHS directive (2002/95/EC)
Object substances : mercury, lead, cadmium, hexavalent chromium, polybrominated biphenyls (PBB) and polybrominated diphenyl ethers (PBDE)
 - Content of six substances specified in Management Methods for Control of Pollution Caused by Electronic Information Products Regulation (Chinese : 电子信息产品污染控制管理办法)

Category	Toxic and hazardous substances					
	Lead (Pb)	Mercury (Hg)	Cadmium (Cd)	Hexavalent chromium (Cr ⁶⁺)	Polybrominated biphenyls (PBB)	Polybrominated diphenyl ethers (PBDE)
Gesture/Ambient light sensor	✓	✓	✓	✓	✓	✓

✓ : indicates that the content of the toxic and hazardous substance in all the homogeneous materials of the part is below the concentration limit requirement as described in SJ/T 11363-2006 standard .

- 5) Country of origin : China
- 6) Product mass : Approx. 0.017g
- 7) Packing : Refer to the attached sheet, Page 16.
- 8) The moisture absorption level of this product is MSL.3.

■Notes

- 1) Notes concerning receiver surface
Please note that it is likely to malfunction when a receiver surface is dirty with garbage and dust, etc. enough. Moreover, please do not touch a receiver surface.
- 2) For cleaning
Cleaning shall carry out as the below items to avoid keeping solvent, solder and flux on the device.
 - Solvent cleaning : Solvent temperature 45°C or less, Immersion for 3 min or less
 - Ultrasonic cleaning : Please don't carry out ultrasonic cleaning.
 - The cleaning shall be carried out with solvent below.
 - Solvent : Ethyl alcohol, Methyl alcohol, Isopropyl alcohol
- 3) Please take proper methods to prevent ESD. The IC built in GP2AP054A00F is ESD-sensitive because it is fabricated by submicron CMOS process. For example, in handling GP2AP054A00F, human body and soldering iron etc. should be grounded.
- 4) Before the circuit design
In circuit designing, make allowance for the degradation of the light emitting diode output that results from long continuous operation. (50% degradation/5 years)
- 5) Notes ambient light
Gesture mode when set to avoid malfunctions due to a strong disturbance light, such an arrangement to receive ambient light directly on the detector, please be avoided. Also by placing this product in close proximity to other components, it may be a malfunction with the light reflected from their product, structural arrangement to reduce the amount of light receiving surface of the outer, please consider.
- 6) After being mounted and soldered, if GP2AP054A00F is deformed by external force or impact, e.g. something falls onto the device, it may result in defective implementation such as lift-off of the terminals. Careful handling should be taken.
- 7) For soldering
Refer to Page 10.

8) Recommended external circuit

(Top View)

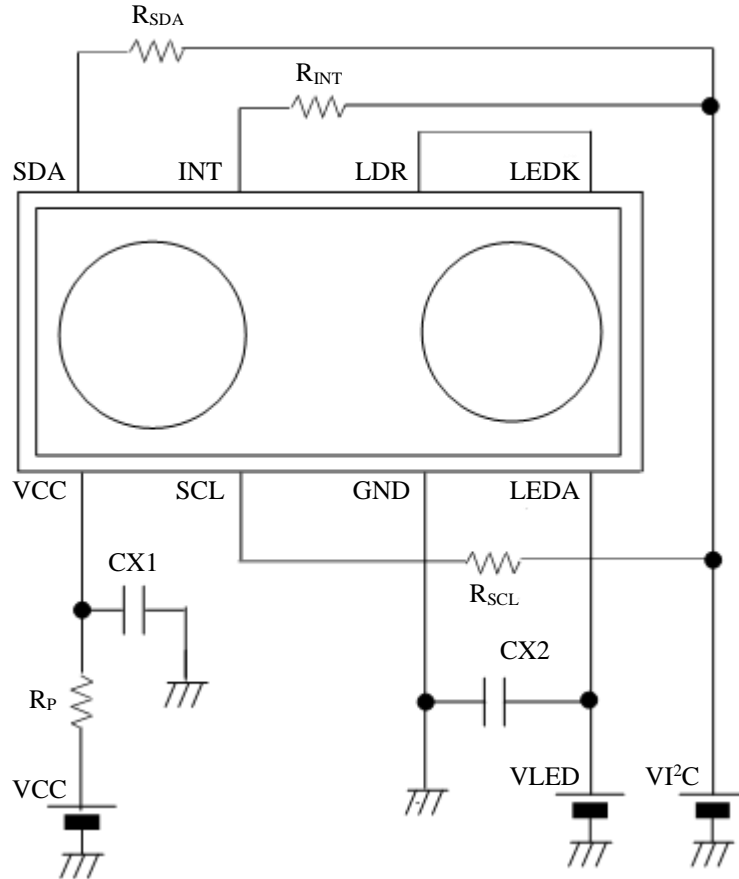

Components	Recommended values
CX1	1μF
CX2	2.2uF
R _P	22Ω
R _{SDA}	10kΩ
R _{SCL}	10kΩ
R _{INT}	100kΩ

There are cases to generate a noise because LED driving current flows LEDA terminal, and to distort a waveform of LED driving current.

To reduce these influences, please arrange CX2 within 5mm from LEDA terminal, and wire between LEDA terminal, CX2 and GND terminal as close as possible. Also, the wiring of VLED is separated from VCC and VPC terminals, and The power source of VLED is separated from VCC is recommended.

And in order to reduce the influence of the power supply noise, please arrange CX1 and R_P within 5mm from VCC terminal.

Please evaluate with the actual electrical implementation, and carefully make sure that there is no problem. SDA terminal (as output) and INT terminal are NMOS open-drain output.

9) Foot pattern of PCB
 (1) Dimensions are shown for reference.

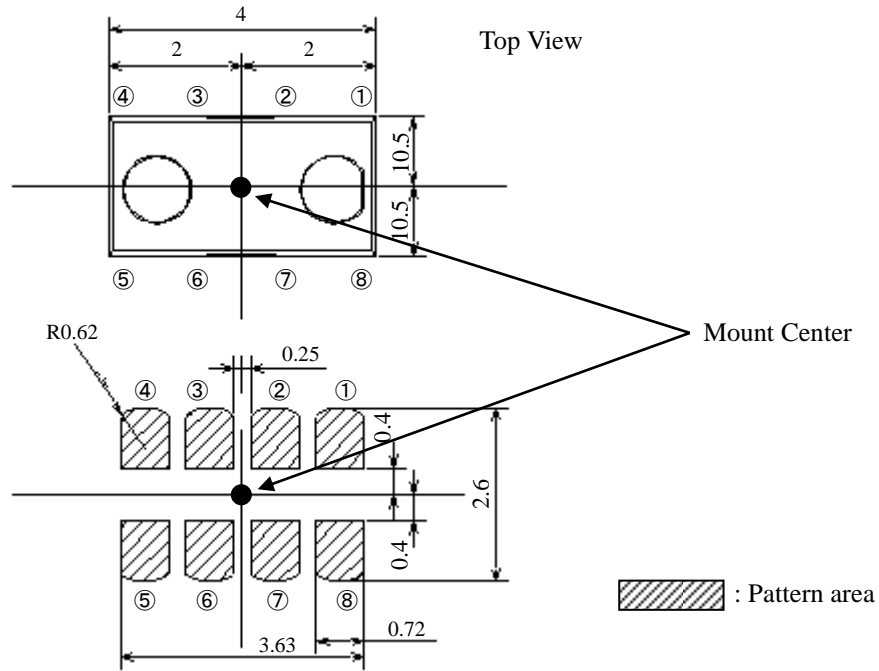

1. Dimension in parenthesis are shown for reference.
 2. Unit : mm

Pin	Pin name	Symbol
①	LED Cathode	LEDK
②	LED driver	LDR
③	Interrupt	INT
④	I ² C Data Bus	SDA
⑤	Supply Voltage	VCC
⑥	I ² C Clock	SCL
⑦	Ground	GND
⑧	LED Anode	LEDA

(2) Recommendable size of solder creamed paste (Reference)

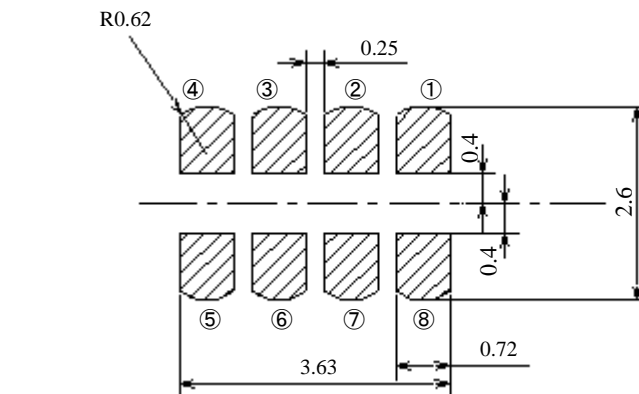

1. Dimensions in parenthesis are shown for reference.
 2. Unit : mm

■ **Precautions for Soldering**

1. In case of solder reflow

Reflow is allowed only three at the temperature and the time within the temperature profile as shown in the figure below.

This Profile temperature is the sensor surface package temperature.

Reflow interval shall be within 7days under conditions, 10 to 30°C, 70%RH or less.

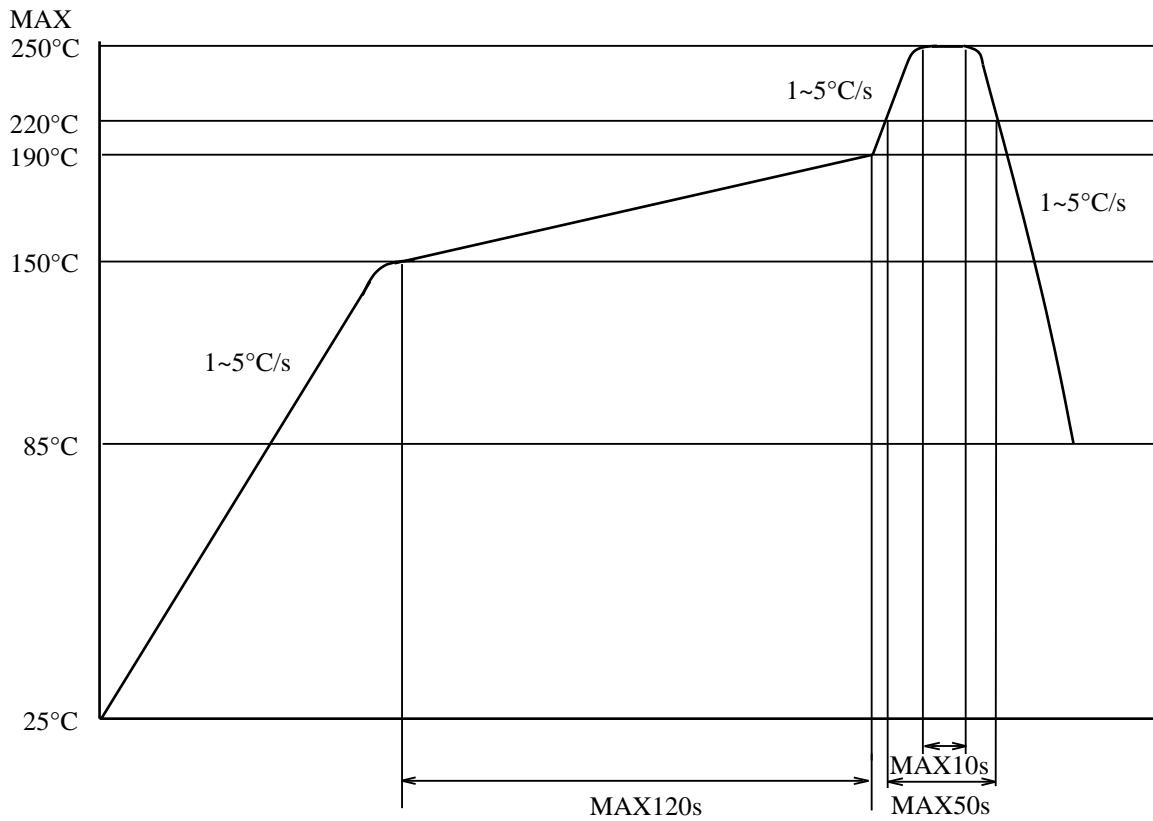

2. Other precautions

An infrared lamp used to heat up for soldering may cause a localized temperature rise in the resin.
 Also avoid immersing the resin part in the soldering.
 Even if within the temperature profile above, there is the possibility that the gold wire in package is broken in case that the deformation of PCB gives the affection to lead pins.
 Please use after confirmation the conditions fully actual solder reflow machine.

■ Taping specifications

1) Application

This packing specification sheets specify the taping specifications for GP2AP054A00F.

2) Taping method

2.1. Tape structure and Dimensions (Refer to page 12.)

The tape shall have a structure in which a cover tape is sealed pressed on the carrier tape of conductive Polycarbonate.

2.2. Reel structure and Dimensions (Refer to page 13.)

The taping reel shall be conductive plastic with its dimensions as shown in the attached drawing.

2.3. Direction of product insertion (Refer to page 13.)

The sensor direction in carrier tape shall be; the emitter of the sensor locates to the feeding hole side of the carrier tape and the detector of sensor faces to the top of the pocket of the carrier tape.

2.4. The way to repair taped failure devices

The way to repair taped failure devices cut a bottom of carrier tape with a cutter, and after replacing to good devices, the cutting portion shall be sealed with adhesive tape.

3) Adhesiveness of cover tape

The exfoliation force between carrier tape cover tape shall be 0.2N to 1.2N for the angle from 160 degrees to 180 degrees.

4) Rolling method and quantity

Wind the tape back on the reel so that the cover tape will be outside the tape.

Attach 16cm or more of blank tape to the trailer and 40cm or more of blank tape to the leader and fix the both ends with adhesive tape.

One reel shall contain 2000pcs. Except for the case that device is removed.

There must not be continuously two or more Stock-Outs.

5) Safety protection during shipping

There shall be no deformation of component or degradation of electrical characteristics due to shipping.

6) Surface resistivity

Name	Material	Surface resistivity (Ω / \square)
Carrier tape	Electroconductive polycarbonate	1×10^4 to 1×10^8
Cover tape	Electroconductive polyester	1×10^4 to 1×10^7
Reel	Poly phenylene ether	Less than 1×10^9

7) Tape and Real structures

7.1 Tape structure and Dimensions

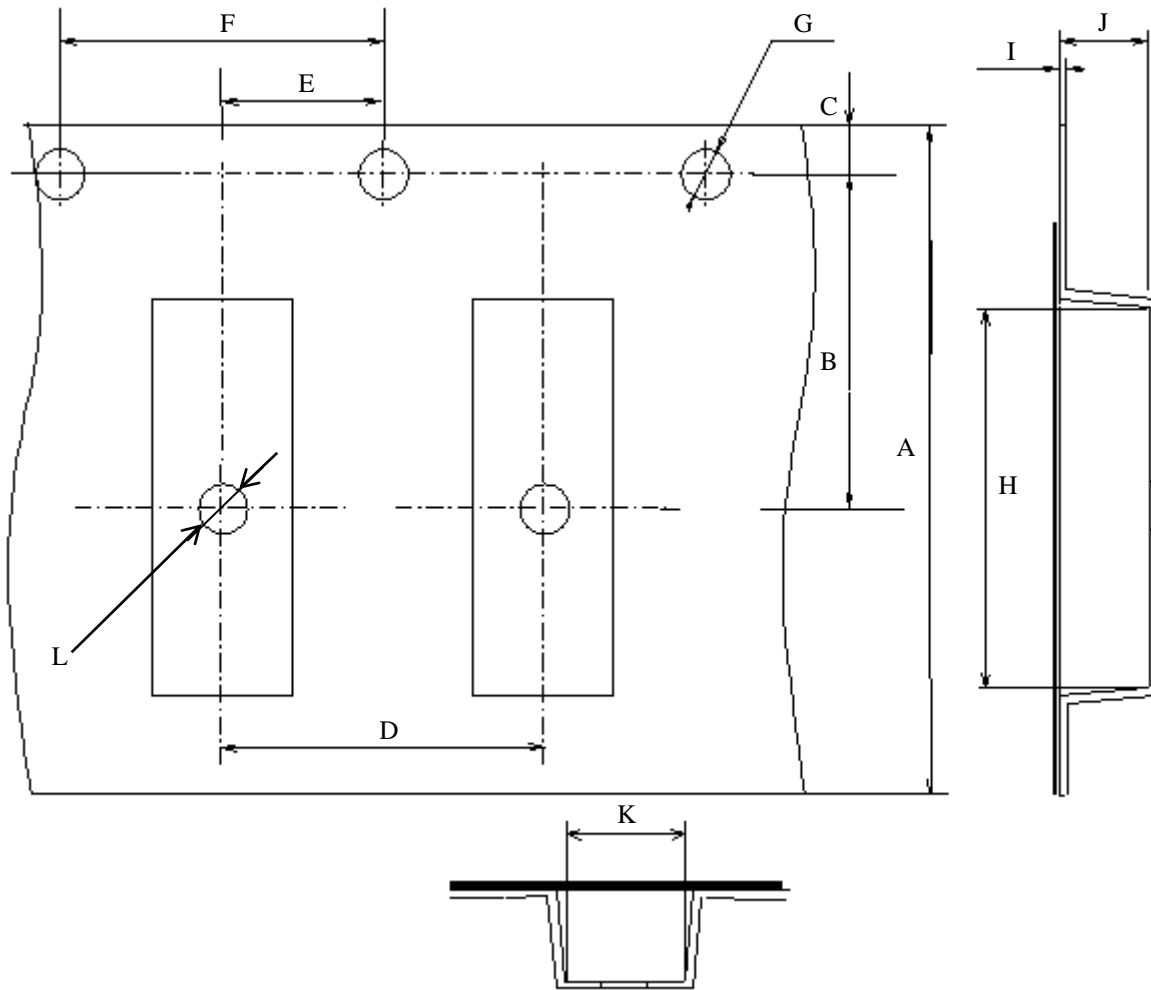

Symbol	A	B	C	D	E	F
Unit						
mm	12.0 ^{±0.3}	5.5 ^{±0.1}	1.75 ^{±0.1}	4.0 ^{±0.1}	2.0 ^{±0.1}	4.0 ^{±0.1}

Symbol	G	H	I	J	K	L
Unit						
mm	φ 1.5 ^{+0.1} _{-0.0}	4.3 ^{±0.1}	0.25 ^{±0.05}	1.4 ^{±0.1}	2.3 ^{±0.1}	φ 1.5 ^{+0.2} _{-0.0}

7.2 Reel structure and Dimensions

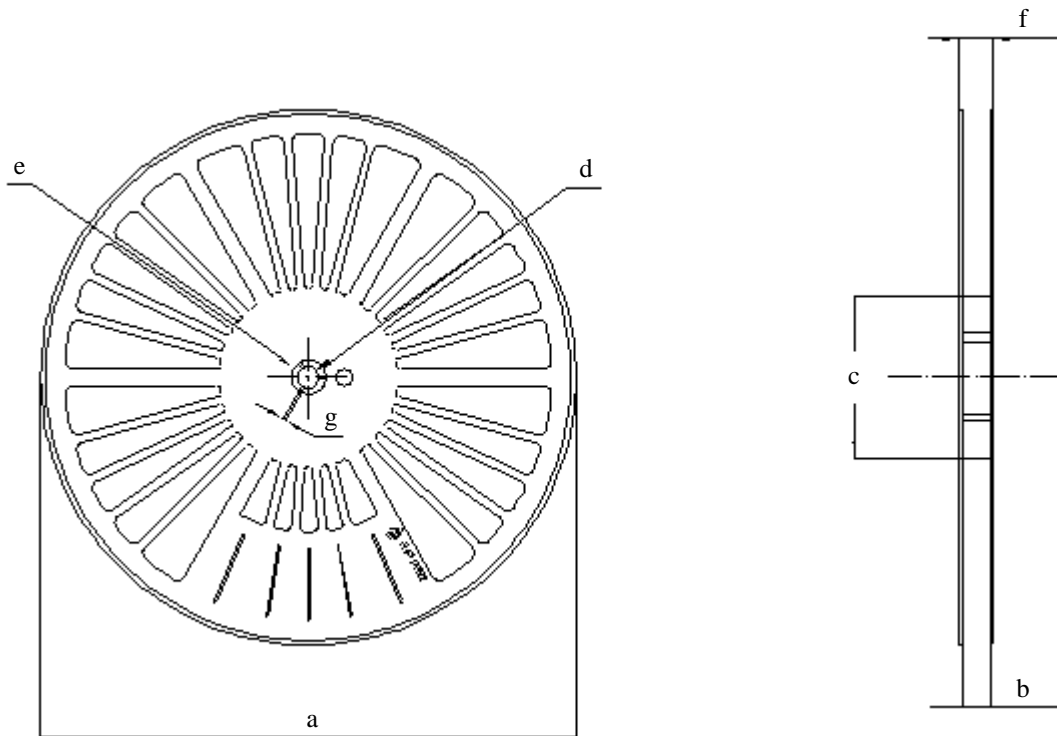

Symbol Unit	Check word						
	a	b	c	d	e	f	g
mm	$\phi 180\pm 2.0$	12 ± 1.0	$\phi 60\pm 1.0$	$\phi 13\pm 0.2$	$\phi 21\pm 0.8$	15.4 ± 1.0	2 ± 0.5

7.3 Direction of product insertion

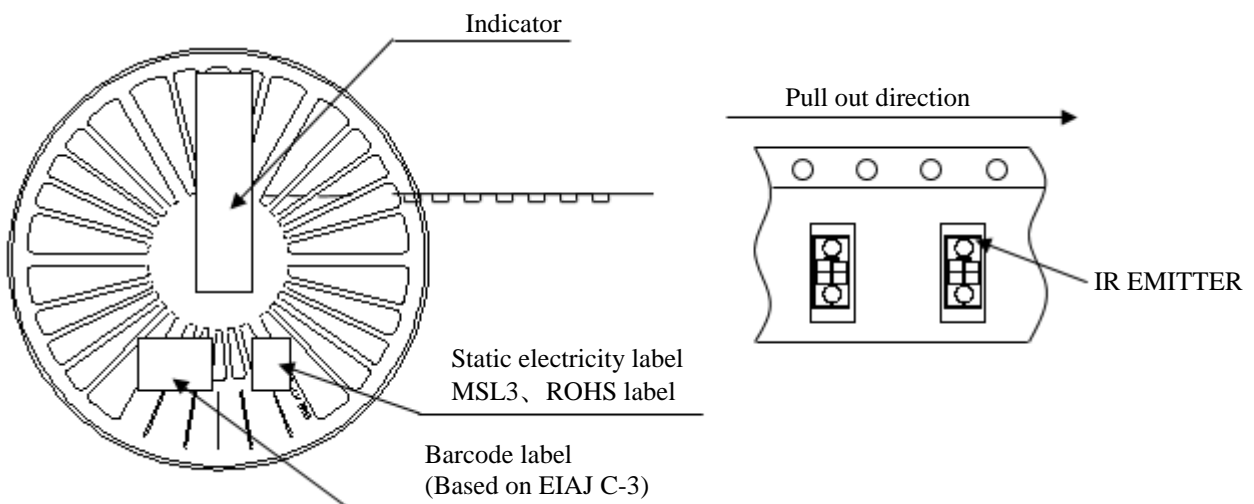

■ **Taping moisture-proof packing**

1) Application

This packing specification sheets apply to the moist-proof packing for the GP2AP054A00F in the taping package.

2) Packaging specifications

2.1. Packaging material

Name	Material	Counter measure for ESD	Quantity
Aluminum laminate bag	Aluminum polyethylene	Conductive type	Refer to 2.2
Label	Paper(-made)	Non	
Siccative	-	Non	
Packing case	Paper	Non	
Cushioning material	Urethane	Non	
Indicator	Paper	Non	

2.2. Packaging method

- (1) Fill necessary information to barcode labels.
- (2) Paste one of the barcode labels and a moisture indicator to a tape reel (contains 2,000 devices per reel).
- (3) Seal the aluminum laminated bag that contains the tape reel and siccative, and paste one of the barcode labels.
- (4) Pack 5 aluminum laminated bags (contains 1 reel each) into the designated packing case, where Urethane cushioning material are placed on the top of the packing case.

Package shape	Product	Quantity	Moisture-proof sack Quantity
Tape reel (φ 180mm)	1 model	2000pcs. / reel *	1reel / laminated bag

Minimum order/shipment quantity should be 1 laminated bag.

- (5) The packing case would be then sealed with the craft tape, with barcode label (based on EIAJ C-3). (Total of 10,000pcs. per carton) * Except for the case that device is removed.

3) Storage and Treatment after Unsealed

3.1. Storage conditions The delivered product should be stored with the conditions shown below;
 Storage temperature : 10 to 30°C
 Humidity : below 70%RH

The warranty term for the shipped product shall be for 1 year after shipping to the designated place by the ordered customer.

3.2. Treatment after open

- (1) After unsealed, devices should be mounted under the temperature condition of 10 to 30°C, at the humidity condition of below 70%RH, within 7days.
- (2) In case that long term storage is needed, devices should either be stored in dry box, or re-sealed to moist-proof bag with siccative and leave them in the environment where the temperature is 10 to 30°C, at the humidity condition of below 70%RH. Devices must be mounted within 2 weeks.

3.3. Baking before mounting

In the event that the devices are not maintained in the storage conditions described above, or the enclosed humidity indicator already turned its color to pink, baking must be applied before devices are to be mounted.

The case that Devices was not mounted under the temperature condition of 10 to 30°C at the humidity condition of below 70%RH or lower within 7 days, Baking process must be applied before devices are to be mounted.: Please also note that baking should only be applied twice.

Recommended condition : ①100 to 110°C, 12 to 24 hours ②125°C, 6 to 24hours

※ Baking will not properly done in packing condition.

To complete the baking properly, devices should be placed to the metal tray.

Recommended condition of reel baking :125°C, 6 to 24hours

※ In the case of reel baking, hung the reel in the oven by passing the shaft in the center hole of reel.
Please avoid laying the reel.

3.4. Placement of reels in an oven

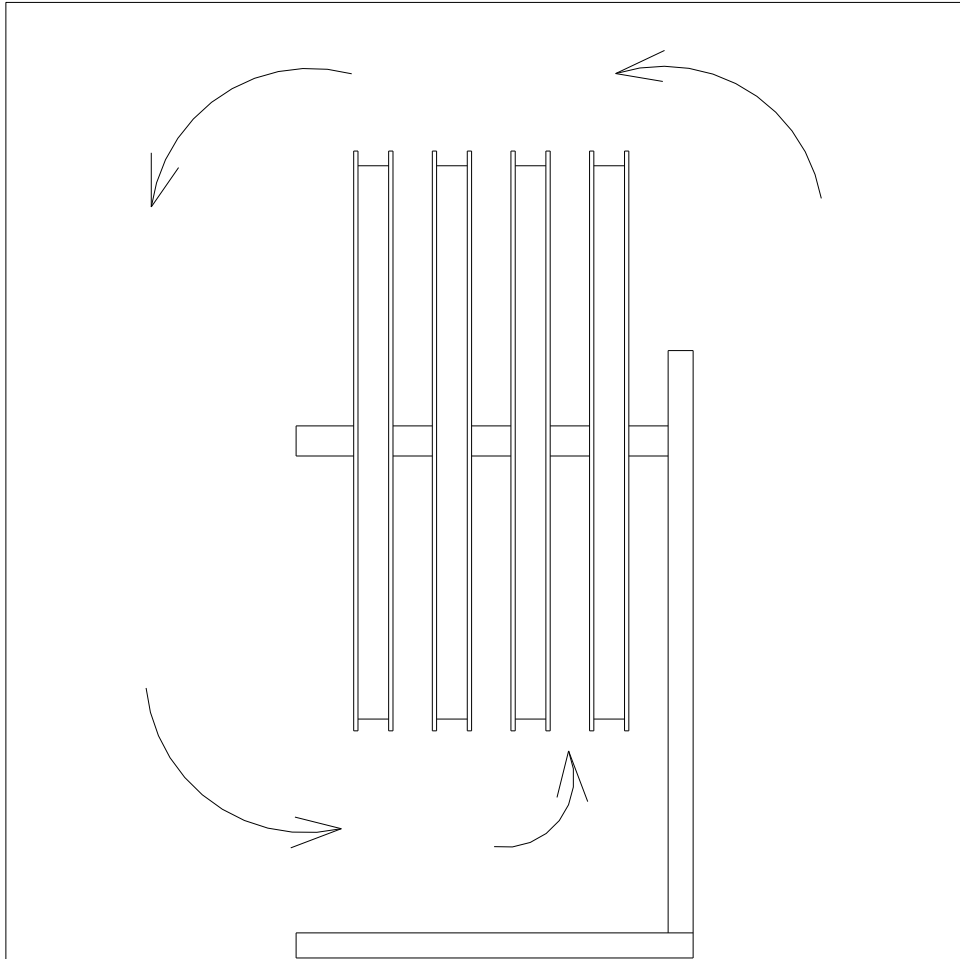

- (1) Please hang reels by using a center hole for fixing the reel.
Please keep some space between reels for better air rotation in the oven.
Please do not lay a reel down in the oven to avoid any damages for the tape edge and the flange of reel.
- (2) Please make sure the carrier tape does not have any slack in a reel before baking to avoid peeling the cover tape off.
Since the tape using for fixing carrier tape is not heatproof, there is a case to remain glue.
So if necessary, please change the tape to a heatproof one.

■ Packing

Inner Packing

① Inner Packing drawing

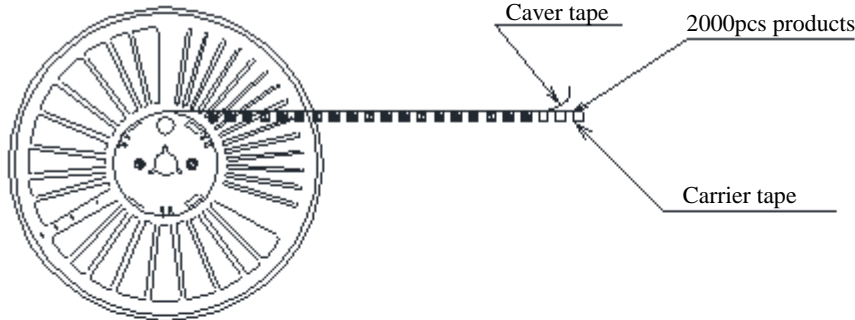

- ② Inner Packing material : • Reel(PPE) • Carrier tape(PC) • Cover tape(PET)
- ③ Quantity : 2000pcs./Reel

Outer Packaging

① Outer packaging drawing

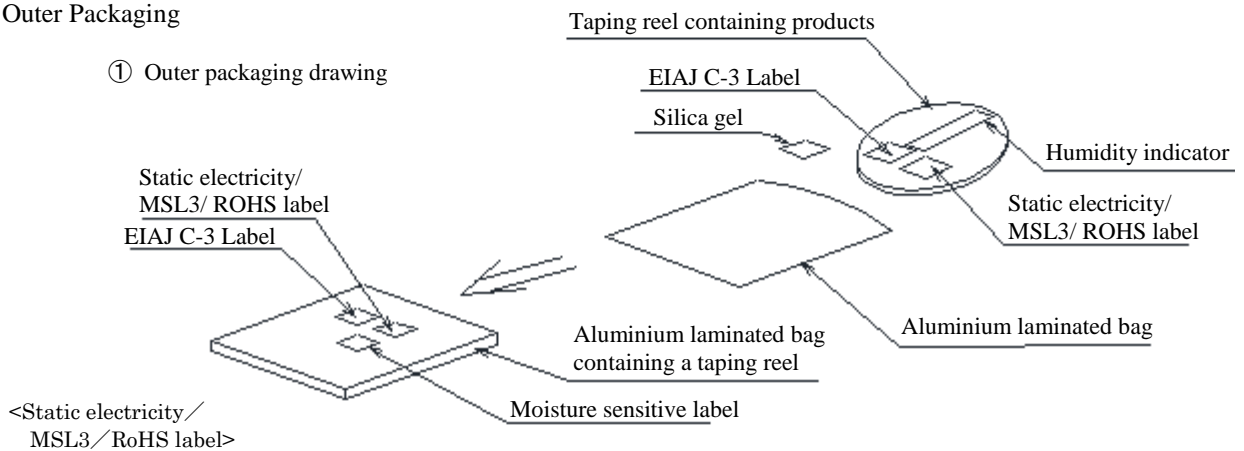

<Static electricity/MSL3/RoHS label>

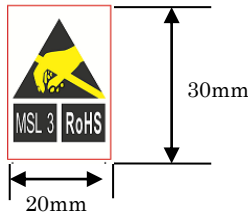

<Moisture sensitive label>

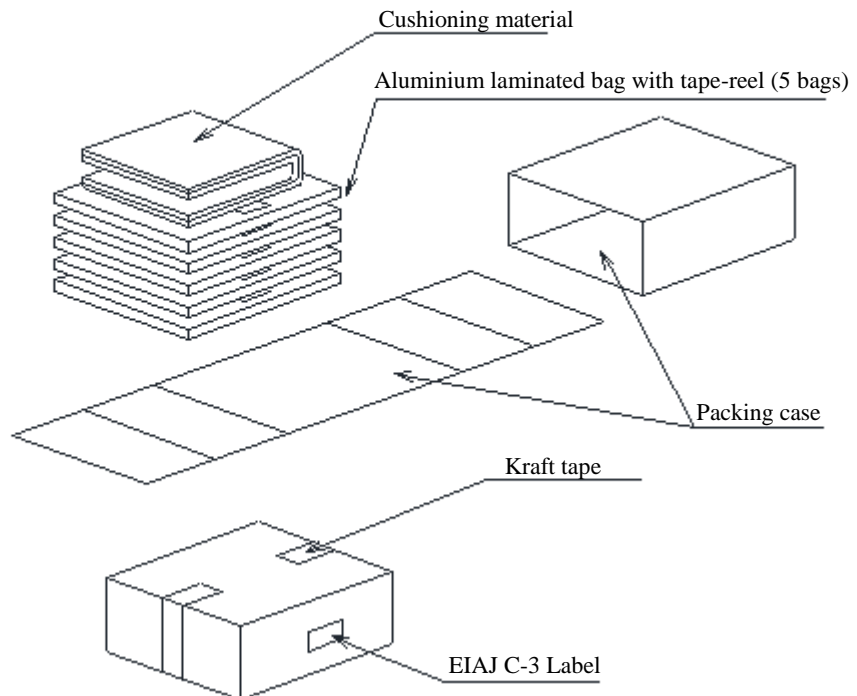
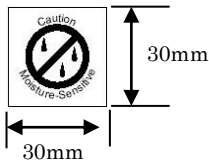

- ② Outer packing material : Packing case (Corrugated cardboard), Cushioning material (Urethane)
Aluminium laminated bag (Alumi-Polyethylene)
Humidity indicator card (paper), Label (paper), silica gel, craft tape
- ③ Quantity : 10000pcs./box
- ④ The contents of the carton indication conforms to EIAJ C-3 and the following items are indicated.
Model No., Internal production control name, Quantity, Packing date, Corporate name, Country of origin
- ⑤ Regular packaged mass : Approximately 700g

■ Important Notices

· The circuit application examples in this publication are provided to explain representative applications of SHARP devices and are not intended to guarantee any circuit design or license any intellectual property rights. SHARP takes no responsibility for any problems related to any intellectual property right of a third party resulting from the use of SHARP's devices.

· Contact SHARP in order to obtain the latest device specification sheets before using any SHARP device. SHARP reserves the right to make changes in the specifications, characteristics, data, materials, structure, and other contents described herein at any time without notice in order to improve design or reliability. Manufacturing locations are also subject to change without notice.

· Observe the following points when using any devices in this publication. SHARP takes no responsibility for damage caused by improper use of the devices which does not meet the conditions and absolute maximum ratings to be used specified in the relevant specification sheet nor meet the following conditions:

(i) The devices in this publication are designed for use in general electronic equipment designs such as:

- Personal computers
- Office automation equipment
- Telecommunication equipment [terminal]
- Test and measurement equipment
- Industrial control
- Audio visual equipment
- Consumer electronics

(ii) Measures such as fail-safe function and redundant design should be taken to ensure reliability and safety when SHARP devices are used for or in connection

with equipment that requires higher reliability such as:

- Transportation control and safety equipment (i.e., aircraft, trains, automobiles, etc.)
- Traffic signals
- Gas leakage sensor breakers
- Alarm equipment
- Various safety devices, etc.

(iii) SHARP devices shall not be used for or in connection with equipment that requires an extremely high level of reliability and safety such as:

- Space applications
- Telecommunication equipment [trunk lines]
- Nuclear power control equipment
- Medical and other life support equipment (e.g., scuba).

· If the SHARP devices listed in this publication fall within the scope of strategic products described in the Foreign Exchange and Foreign Trade Law of Japan, it is necessary to obtain approval to export such SHARP devices.

· This publication is the proprietary product of SHARP and is copyrighted, with all rights reserved. Under the copyright laws, no part of this publication may be reproduced or transmitted in any form or by any means, electronic or mechanical, for any purpose, in whole or in part, without the express written permission of SHARP. Express written permission is also required before any use of this publication may be made by a third party.

· Contact and consult with a SHARP representative if there are any questions about the contents of this publication.



Компания «ЭлектроПласт» предлагает заключение долгосрочных отношений при поставках импортных электронных компонентов на взаимовыгодных условиях!

Наши преимущества:

- Оперативные поставки широкого спектра электронных компонентов отечественного и импортного производства напрямую от производителей и с крупнейших мировых складов;
- Поставка более 17-ти миллионов наименований электронных компонентов;
- Поставка сложных, дефицитных, либо снятых с производства позиций;
- Оперативные сроки поставки под заказ (от 5 рабочих дней);
- Экспресс доставка в любую точку России;
- Техническая поддержка проекта, помощь в подборе аналогов, поставка прототипов;
- Система менеджмента качества сертифицирована по Международному стандарту ISO 9001;
- Лицензия ФСБ на осуществление работ с использованием сведений, составляющих государственную тайну;
- Поставка специализированных компонентов (Xilinx, Altera, Analog Devices, Intersil, Interpoint, Microsemi, Aeroflex, Peregrine, Syfer, Eurofarad, Texas Instrument, Miteq, Cobham, E2V, MA-COM, Hittite, Mini-Circuits, General Dynamics и др.);

Помимо этого, одним из направлений компании «ЭлектроПласт» является направление «Источники питания». Мы предлагаем Вам помощь Конструкторского отдела:

- Подбор оптимального решения, техническое обоснование при выборе компонента;
- Подбор аналогов;
- Консультации по применению компонента;
- Поставка образцов и прототипов;
- Техническая поддержка проекта;
- Защита от снятия компонента с производства.



Как с нами связаться

Телефон: 8 (812) 309 58 32 (многоканальный)

Факс: 8 (812) 320-02-42

Электронная почта: org@eplast1.ru

Адрес: 198099, г. Санкт-Петербург, ул. Калинина, дом 2, корпус 4, литера А.