



KSZ8382

Entry-Level IP Phone SOC Solution Preliminary Product Brief

Integrated IP Phone on a Chip

Description

The Micrel KSZ838x IP Phone on a Chip SOC supplies a complete IP phone solution for enterprise and residential IP telephony, implementing a compact, green, and low-cost IP phone. The KSZ8382 is a highly integrated SoC designed to enable a new generation of functionality for **Green** IP phones.

The KSZ8382 SoC is the ideal choice for entry-level enterprise and residential IP phones, backed by Micrel's high-reliability and solution robustness proven in commercial, industrial, and automotive applications around the globe.

The KSZ8382 implements a multiprocessor architecture with embedded RISC CPU and powerful DSP, providing a flexible VoIP platform with narrowband and wideband voice processing and excellent voice quality.

The chip's superior integration increases performance and reduces BOM cost, featuring a high-performance audio subsystem, LCD interface, keypad scanner, memory

controllers for both SDRAM and DDR2, and flexible GPIO.

Micrel integrates the industry's most robust, and lowest-power 10/100 Ethernet Switch, implementing critical functionality for IP telephony including IEEE 802.1p priority QoS, 802.1Q VLANs, and IGMP v1/v2 snooping for multicast packet filtering. The part implements innovative advanced power management including Energy Efficient Ethernet PHY technology (IEEE 802.3az).

Applications

- Entry-Level Enterprise IP Phones
- Entry-Level Residential IP Phones
- Entry-level phones for emerging markets

System Configurations

- IP Phone on a Chip with 3-port, 10/100 switch
- SDRAM and DDR2 Memory

KSZ8382 Functionality:

- MIPS32 RISC CPU for configuration and network protocol processing
 - External SDRAM, DDR2, and Flash interfaces
- ZSP400 DSP offers high-quality voice/audio processing
- 8kHz/16kHz 16-bit ADC/DAC with integrated amplifiers
- Embedded VoIP Firmware (DSP)
 - Wideband CODECs: G.722, G.722.1, G.722.2
 - Narrowband CODECs: G.711 μ -law/A-law, G.723.1, G.726, G.729A/B
 - Voice quality optimizations
 - Telephony features
- 3-port 10/100BaseT Ethernet Switch with integrated low-power PHY transceivers supporting IEEE 802.3az Energy Efficient Ethernet
- Flexible GPIO support
- Keypad Scanner: 6x6 and 8x8 keypad configurations
- LCD Interface

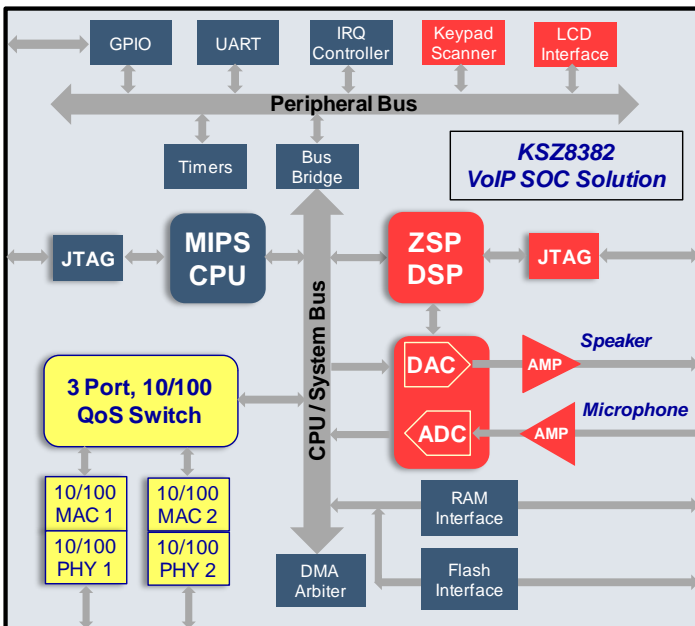

KSZ8382 Internal Block Diagram

KSZ8382 IP Phone on a Chip Features	Benefits
Highest-level of integration	Reduces IP Phone BOM cost Compact footprint Low power consumption
Multiprocessing architecture with RISC and DSP	General-purpose CPU exposed for host application Proven DSP optimized for voice/telephony processing
On-chip audio subsystem with integrated ADC/DAC, amplifiers, and input/output multiplexers	Enables low-cost connection to handset, headset, and speakerphone with minimal external components
3-port 10/100 Base-T Ethernet Switch with integrated PHY transceivers	Low-power design with comprehensive IEEE 802 LAN functionality for priority, VLANs, and QoS
Flexible SDRAM, DDR2, and Flash memory controller	Enable maximum flexibility and growth to accommodate various storage technologies/capacities
Advanced power management	Industry's lowest power Ethernet switch, achieving a Green and low-cost design
JTAG support for embedded RISC CPU and DSP	Enables efficient debugging, reduces time to market



Micrel VoIP KSZ8382L IP Phone SOC Evaluation Board:

- Evaluation Platform for Micrel VoIP KSZ8382L Single-Chip IP Phone SOC solution
- Enables OEM bring-up of complete SIP IP Phone solution, phone call functions, and user interface
- Software programmable with interfaces for audio hardware devices and for PC control
- Shipped with complete Micrel-supplied VoIP and SIP IP Phone protocol software stack
 - Includes VoIP G.7xx Voice CODECs and DSP-based Voice Quality Enhancement firmware





Компания «ЭлектроПласт» предлагает заключение долгосрочных отношений при поставках импортных электронных компонентов на взаимовыгодных условиях!

Наши преимущества:

- Оперативные поставки широкого спектра электронных компонентов отечественного и импортного производства напрямую от производителей и с крупнейших мировых складов;
- Поставка более 17-ти миллионов наименований электронных компонентов;
- Поставка сложных, дефицитных, либо снятых с производства позиций;
- Оперативные сроки поставки под заказ (от 5 рабочих дней);
- Экспресс доставка в любую точку России;
- Техническая поддержка проекта, помощь в подборе аналогов, поставка прототипов;
- Система менеджмента качества сертифицирована по Международному стандарту ISO 9001;
- Лицензия ФСБ на осуществление работ с использованием сведений, составляющих государственную тайну;
- Поставка специализированных компонентов (Xilinx, Altera, Analog Devices, Intersil, Interpoint, Microsemi, Aeroflex, Peregrine, Syfer, Eurofarad, Texas Instrument, Miteq, Cobham, E2V, MA-COM, Hittite, Mini-Circuits, General Dynamics и др.);

Помимо этого, одним из направлений компании «ЭлектроПласт» является направление «Источники питания». Мы предлагаем Вам помощь Конструкторского отдела:

- Подбор оптимального решения, техническое обоснование при выборе компонента;
- Подбор аналогов;
- Консультации по применению компонента;
- Поставка образцов и прототипов;
- Техническая поддержка проекта;
- Защита от снятия компонента с производства.



Как с нами связаться

Телефон: 8 (812) 309 58 32 (многоканальный)

Факс: 8 (812) 320-02-42

Электронная почта: org@eplast1.ru

Адрес: 198099, г. Санкт-Петербург, ул. Калинина, дом 2, корпус 4, литера А.