



ON Semiconductor®

<http://onsemi.com>

# LA72912V

## Monolithic Linear IC FM Modulator and Demodulator IC

### Overview

The LA72912V is a FM modulation and demodulation single-chip IC. Its adjustment free modulation/demodulation circuit significantly reduces the number of peripheral circuits required and can contribute to lower production costs.

### Functions

- ASK modulation and demodulation
- Video signal FM modulation and demodulation
- Video signal emphasis and de-emphasis function
- Drop-Out detecting function of Video FM signal
- FM mute function at Second-Call

### Specifications

#### Maximum Ratings at $T_a = 25^\circ\text{C}$

Parameter	Symbol	Conditions	Ratings	Unit
Maximum supply voltage	$V_{CC \text{ max}}$		7.0	V
Allowable power dissipation	$P_d \text{ max}$		300	mW
Operating temperature	$T_{opr}$	$T_a \leq 70^\circ\text{C}^*$	-30 to +70	$^\circ\text{C}$
Storage temperature	$T_{stg}$		-40 to +150	$^\circ\text{C}$

\* Mounted on a 114.3mm × 76.1mm × 1.6mm, glass epoxy board.

Stresses exceeding Maximum Ratings may damage the device. Maximum Ratings are stress ratings only. Functional operation above the Recommended Operating Conditions is not implied. Extended exposure to stresses above the Recommended Operating Conditions may affect device reliability.

#### Recommended Operating Conditions at $T_a = 25^\circ\text{C}$

Parameter	Symbol	Conditions	Ratings	Unit
Recommended supply voltage	$V_{CC}$		5.0	V
Allowable operating voltage range	$V_{CC \text{ op}}$	$T_a = -30 \text{ to } +70^\circ\text{C}$	4.7 to 5.5	V

# LA72912V

**Electrical Characteristics** at Ta = 25°C, VCC = 5V

**DC CHARACTERISTICS** T6 = 0.4V, T17 = 2.0V, T18 = 0.4V

Parameter	Symbol	In	OUT	Conditions	Ratings			Unit
					min	typ	max	
Control terminal (Pin6,9) Low level	CNT6L CNT17L	T6	T17	Low level of control terminal of ALL mode. T6 = 0.4V(DEMOD mode), T17 = 0.4V (Standby mode)	0		0.4	V
Control terminal (Pin6,9)High level	CNT6H CNT17H	T6	T17	High level of input terminal of ALL mode T6 = 2.0V (MOD mode), T17 = 2.0V (Normal mode)	2.0		5.0	V
Input5 Low level	IN5L	T5		Low level of input terminal of MOD mode T6 = 2.0V, T17 = 2.0V, T18 = 0.4V	0		0.4	V
Input5 High level	IN5H	T5		High level of input terminal of MOD mode T6 = 2.0V, T17 = 2.0V, T18 = 0.4V	2.0		5.0	V
Input18 Low level	IN18L	T18		Low level of input terminal of MOD mode T5 = 0.4V, T6 = 2.0V, T17 = 2.0V	0		0.4	V
Input18 High level	IN18H	T18		High level of input terminal of MOD mode T5 = 0.4V, T6 = 2.0V, T17 = 2.0V	2.0		5.0	V
Output18 terminal High level	OPH18		T18	DEMODO mode: FM-Signal input T6 = 0.4V, T17 = 2.0V, Pull-UP:15KΩ	4.7			V
Output18 terminal Low level	OPL13 OPL18		T18	T18: DEMODO mode: FM No-signal Measure the sink level of output terminal. T6 = 0.4V, T17 = 2.0V, Pull-UP:15KΩ	0	0.25	0.4	V
Input20 Low level	IN20L	T20	T20	Voltage of terminal at AGC ON T6 = 0.4V, T17 = 2.0V	0		3	V
Input20 High level	IN20H	T20	T20	Voltage of terminal at AGC OFF T6 = 0.4V, T17 = 2.0V	4.5		5.0	V
5pin AC input dynamic range	ACIN5	T5A	T3	Input amplitude level of FM signal Freq: 11.5MHz to 13.5MHz			1000	mVp-p
16pin AC input dynamic range	ACIN16	T24A	T3	Maximum input level of T24A at Video signal			1.5	Vp-p

**Video FM Modulation Block (MOD)** T6=2.0V,T17=2.0V,T18=0.4V

Parameter	Symbol	In	OUT	Conditions	Ratings			Unit
					min	typ	max	
Current dissipation	ICCR			measure the currents into pins 2 (MOD mode)	22.0	27.0	32.0	mA
FM modulator output level	VFM1		T3	Measure the output level on T3 (No signal input) It is load impedance 200Ω between T3-GND.		1.8	2.2	Vp-p
FM Mute output level	VFM2		T3	Measure the T3 output level with 2nd call	0	10	20	mVp-p
Carrier frequency	FFM		T3	Measure the output frequency on T3 with no signal input	10.9	11.5	12.1	MHz
FM output Second harmonic distortion	THD2		T3	Measure the second harmonics distortion with the above condition		-30	-20	dB
Deviation	DEV	T24A	T3	With T24A 100% White 1Vp-p signal, Measure the deviation on T3	1.9	2.0	2.1	MHz
FM modulator linearity (11.5MHz to 13.5MHz)	LMOD	T24A	T3	Let f2.85, f3.35 and f3.85 be the output frequency when 2.85V, 3.35V and 3.85V is applied to T24A $L_{MOD} = \frac{f_{3.35} - (f_{3.85} + f_{2.85}) / 2}{f_{3.85} - f_{2.85}} \times 100$	-2	0	+2	%
Emphasis gain	GEMP	T24A	T20	With VIN a 300mVp-p 10kHz sine wave, Measure the ratio of the levels on T24A and T20	-7.5	-6.0	-4.5	dB
Main linear emphasis characteristics(1)	GME1	T24A	T20	With VIN a 300mVp-p 500kHz sine wave, Measure the ratio of the levels on T24A and T20	0.0	1.5	3.0	dB
Main linear emphasis characteristics(2)	GME2	T24A	T20	With VIN a 300mVp-p 2MHz sine wave, Measure the ratio of the levels on T24A and T20	4.0	5.5	7.0	dB
White clipping level	LWC	T24A	T20	With VIN a 1.5Vp-p 100% white video signal. Measure the white clipping level on T20	180	200	220	%
Dark clipping level	LDC	T24A	T20	With VIN a 1.5Vp-p 100% white video signal. Measure the dark clipping level on T20.	-60	-50	-40	%
FM stop beginning delay time (VD characteristic 1B)	TC1	T5	T3	C7 = 0.01μF, Time from fall of T5 signal to doing of FM carrier of T3 STOP	240	300	360	μs
FM stop time (VD characteristic2A)	TC2	T5	T3	C8 = 0.001μF, Stop time of FM carrier of T3	30	40	50	μs
Minimum VD pulse width	VDT	T5	T3	C7 = 0.01μF, Minimum VD pulse width to which TC1B is normally output	63			μs

# LA72912V

## Video FM De-modulation Block (DEM0D) T6=0.4V,T17=2.0V

Parameter	Symbol	In	OUT	Conditions	Ratings			Unit
					min	typ	max	
Current dissipation	I <sub>CCP</sub>			Measure the currents into pin 2 (DEM0D mode)	26.0	32.0	38.0	mA
Video output level	V <sub>OUT</sub>	T5A	T3	Demodulation level, when the FM signal of 2.2MHz deviation. Load impedance = 1kΩ T3-GND.	2.09	2.2	2.31	Vp-p
Video output level B	V <sub>OUTB</sub>	T5A	T3	Demodulation level, when the FM signal of 2.0MHz deviation. Load impedance = 1kΩ T3-GND. (In this case only, V <sub>CC</sub> make 4.5V to 5.5V.)	1.9	2.0	2.1	Vp-p
FM stop detection level (DOC characteristic 1)	DOC1	T5A T20	T18 T20	T5 = 11.5MHz, 300mVp-p. Measure T20 voltage (V20). Set T20 V20 (AGC-Fix). T5 input level when T5 amplitude is decrease gradually, and T18 becomes "Low"		40	60	mVp-p
(Drop Delay Down)	DDD	T5A T20	T18 T20	Shift time from T5 = 300mVp-p → 0mVp-p to T18 "Low".	0.5	1.5	2.5	μs
FM return judgment level	DOC2	T5A T20	T18 T20	T5 = 11.5MHz, 300mVp-p, Measure T20 Voltage (V20). Set T20 V20 (AGC-Fix). T5 inputs the level when T5 amplitude is increase gradually, and T18 becomes "High"		60	90	mVp-p
Video DC level when returning	DOC2B	T5A T20	T23	Confirmation of output of Video signal from T3. Measurement of DC level.	0.5	1.0	1.5	V
(Drop Delay Rise) Return operation delay time	DWR	T5A T20	T18 T20	Shift time from T5 = 0mVp-p → 300mVp-p to T18 "High"	0.2	1.5	2.5	μsec
4V Regulator	VREG		T4	Measurement of T4 DC level.	3.9	4.0	4.3	V
Range of input Dynamic range	ACIN5	T5A	T3	DEV = 2.0MHz. Input amplitude level of FM signal. (T5A: 11.5MHz to 13.5MHz)		500	1000	mVp-p
DG	DG	T5A	T3		0	6	10	%
DP	DP	T5A	T3		0	6	10	deg
Output voltage at mute	MUV		T3	Mute level measurement of T3	0	10	20	IRE
FM demodulation voltage (11.0M)	VDEM11 VDEM12 VDEM13	T5A	T23	T5A = 11.0MHz, 100mVp-p, 200mVp-p and 400mVp-p. Each T23 voltage measurement	0.3	0.8	1.3	V
FM demodulation voltage (12.5M)	VDEM21 VDEM22 VDEM23	T5A	T23	T5A = 12.5MHz, 100mVp-p, 200mVp-p and 400mVp-p. Each T23 voltage measurement	0.7	1.2	1.7	V
FM demodulation voltage (14.0M)	VDEM31 VDEM32 VDEM33	T5A	T23	T5A = 14MHz, 100mVp-p, 200mVp-p and 400mVp-p Each T23 voltage measurement	1.1	1.6	2.1	V
FM demodulation linearity1,2,3	LDEM1 LDEM2 LDEM3			Calculate FM demodulation linearity LDEM1 = {[VDEM21 - (VDEM11 + VDEM31) / 2] / (VDEM31 - VDEM11)}×100 LDEM2 = {[VDEM22 - (VDEM12 + VDEM32) / 2] / (VDEM32 - VDEM12)}×100 LDEM3 = {[VDEM23 - (VDEM13 + VDEM33) / 2] / (VDEM33 - VDEM13)}×100	-2	0	+2	%
FM demodulation Sensitivity1,2,3	SDEM1 SDEM2 SDEM3			Calculate FM recovery Sensitivity with consider pin 3 output level conversion ratio. SDEM1 = (VDEM31-VDEM11)/3.0 SDEM2 = (VDEM32-VDEM12)/3.0 SDEM3 = (VDEM33-VDEM13)/3.0	0.28	0.33	0.38	V/MHz
Main linear de-emphasis amplitude	GMED	T5A	T23	T5 = 200mVp-p FM signal (fm = 10kHz, Center Carrier = 12.5MHz, DEV = 2.0MHz) Signal level of T23	481	535	589	mVp-p
Main linear de-emphasis Characteristics(1)	GMED1	T5A	T23	T5 = 200mVp-p FM signal (fm = 500kHz, Center Carrier = 12.5MHz, DEV = 2.0MHz). Signal level of T23 versus GMRD (Ratio of GMED).	-3.5	-1.5	+0.5	dB
Main linear de-emphasis Characteristics(2)	GMED2	T5A	T23	T5 = 200mVp-p FM signal (fm = 2MHz, Center Carrier = 9.25MHz, DEV = 2.0MHz). Signal level of T23 versus GMRD (Ratio of GMED)	-6.5	-4.5	-2.5	dB

## LA72912V

### ASK Block T17=0.4V

Parameter	Symbol	In	OUT	Conditions	Ratings			Unit
					min	typ	max	
Current dissipation at standby	I <sub>CCS</sub>	T17		At standby mode, measures include current to pin2,9. T17 = 0.4V, T15 and T20:open	10.8	13.0	15.5	mA
Current dissipation at standby at MOD-AGC-OFF	I <sub>CCSb</sub>	T17 T15		At standby mode, measures include current to pin2,9. T17 = 0.4V, T15 = 5V, T20:open	12.8	16.0	19.2	mA
Current dissipation at standby at DEMOD-AGC-OFF	I <sub>CCSc</sub>	T17 T15 T20		At standby mode, measures include current to pin2,9. T17 = 0.4V, T15 = 5V, T20 = 5V	16.8	21.0	25.2	mA
Standby release time(1) (FM stop→release)	S <sub>ASK1</sub>	T6 T17	T3	T6 = 2.0VDC T17 = 0V→2V (Standby release) Time until FM carrier is output to T3.	0.0	6.0	12.0	μs
Standby release time(2) (Video signal stop →release)	S <sub>ASK2</sub>	T6 T5A T17	T3	T6 = 0.4V, T5 = DEV = 2.0MHz 100% white video signal of FM signal. T17 = 0V → 2V (Standby release) Time until white 100% signal is output to T3	2.0	7.0	12.0	μs
ASK Transmitting time "transmission"	T <sub>ASK1</sub>	T10A T11	T12	T10A = 1MHz,0/2V Pulse T11 = 20KHz, 0/2VPulse. Measure T12 signal appear time			0.1	ms
ASK Transmitting time "Receive"	T <sub>ASK2</sub>	T16A	T13	T16 = 1MHz, 300mVp-p-SIN wave Measure time T13 appear detected T16 signal			0.1	ms
ASK transmission setup time	W <sub>ASK</sub>	T10A T11	T12	T10A = 1MHz, 0-2V-pulse T11 = 20KHz,0-2V-pulse Measure T11 input interval time when T10A input		10	100	ms
ASK minimum detect level	V <sub>ASK</sub>	T16A	T13	Measure T16 minimum level at T13 is normally condition	0.2		3	Vp-p
ASK start up time	O <sub>ASK</sub>	T16A	T13	Measure time ASK working from Power-ON	-	30	300	ms
ASK demodulation duty ratio	D <sub>ASK</sub>	T16A	T13	T16 = T12 output signal (0-2Vp-p) Measure ASK Duty difference with 50% DASK = (pulse width μs / 50μs) - 50% × 100%	-15	-2	11	%

# LA72912V

## Package Dimensions

unit : mm (typ)  
3175C

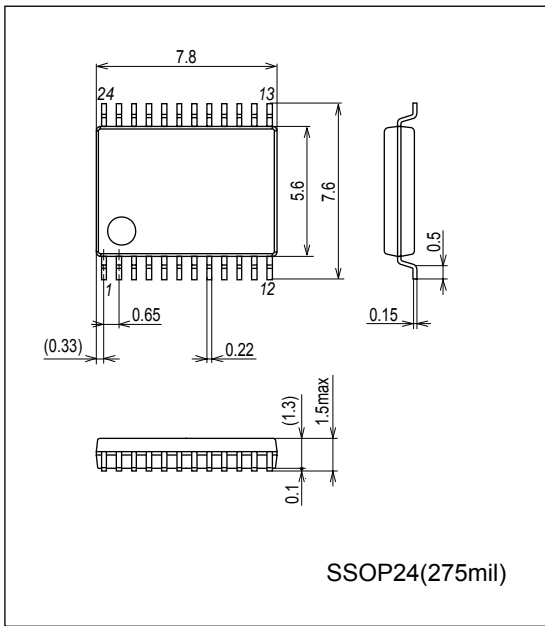

## Pin Assignment

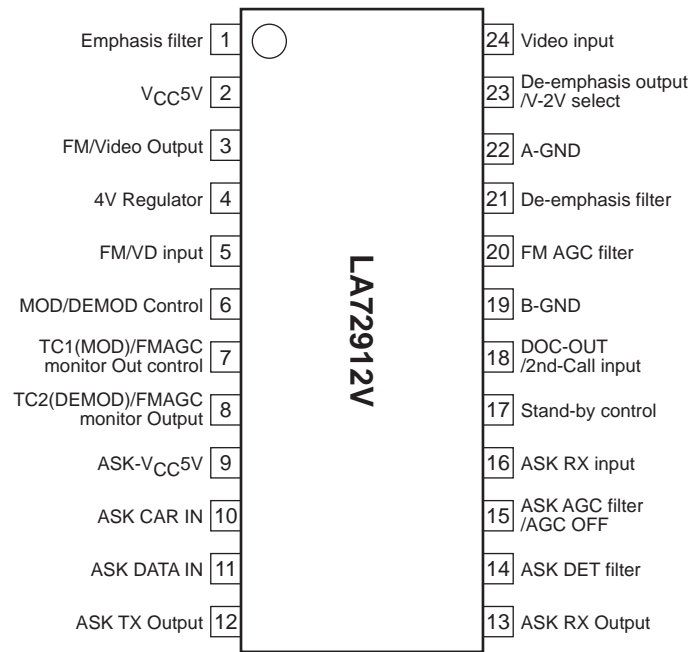

Top view

# LA72912V

## Block Diagram and Application Circuit Example1 Modulation (Outside camera)

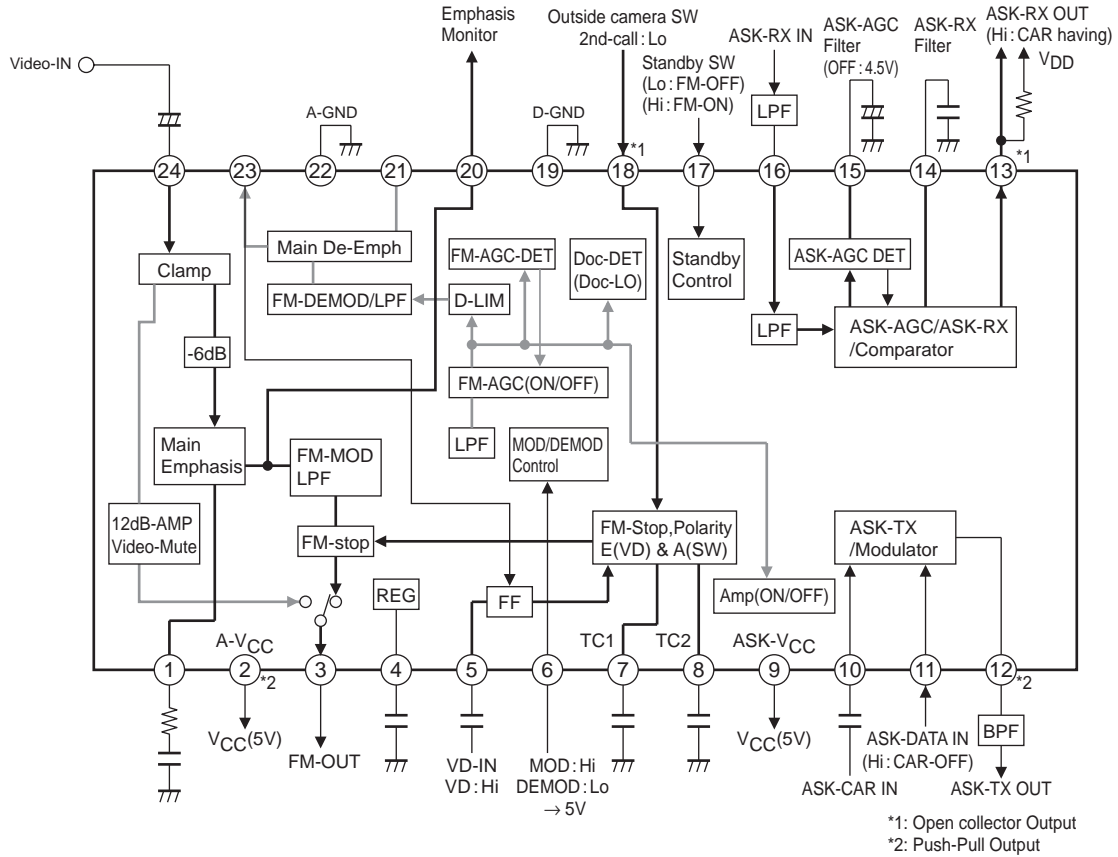

## Application Circuit Example2 Demodulation (Inside monitor)

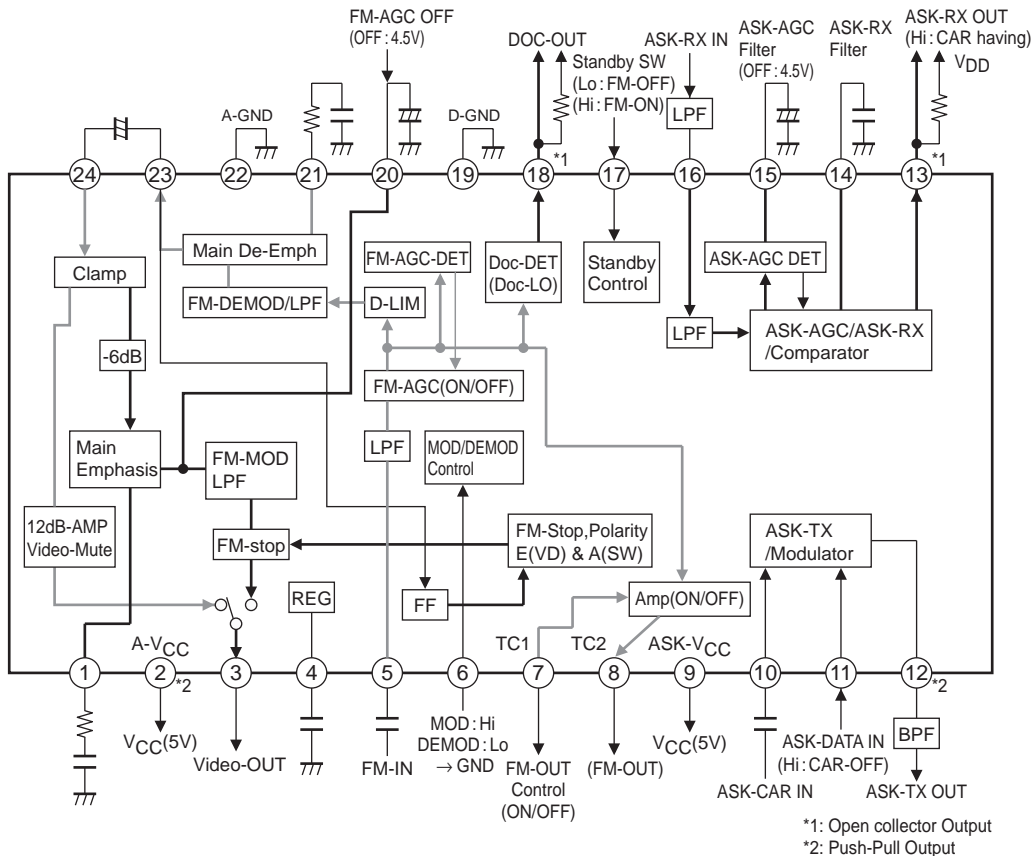

# LA72912V

## Pin Function

Pin No.	Pin name	FM MOD mode(Outside camera)	FM DEMOD mode(Inside Monitor)	Note
1	Emphasis filter	Emphasis filter connection pin	Non connect(Hi-Z)	If you no need, this pin is open.
2	V <sub>CC</sub> 5V	V <sub>CC</sub> for FM modulation.	V <sub>CC</sub> for FM demodulation.	
3	FM/Video Output	FM Output (R <sub>O</sub> =200Ω:1.8Vp-p)	Video Output (R <sub>O</sub> =1kΩ: 2Vp-p)	Push-pull output
4	4V Regulator	FM modulate block and ASK bock supply reference voltage.	FM demodulate block and ASK bock supply reference voltage.	
5	FM/VD input	VD Input. (Hi: over 2V, Low: under 0.4V) (VD DET: High)	FM Input. (Recommend Level: 100 to 620mVp-p)	DEMODO mode: Set 3.3V by internal bias. (34kΩ/66kΩ)
6	MOD/DEMODO Control	Set over 2V DC voltage.	Set under 0.4V DC voltage.	Outside camera / Inside monitor setting.
7	TC1(MOD)/ FMAGC monitor Out control	Set capacitor for TC1	FMAGC monitor out control GND: Monitor ON / V <sub>CC</sub> : Monitor OFF	Can do second inside monitor addition
8	TC2(DEMODO)/ FMAGC monitor Output	Set capacitor for TC2	FMAGC monitor output	Can do second inside monitor addition
9	ASK-V <sub>CC</sub> 5V	V <sub>CC</sub> for ASK	←	
10	ASK CAR IN	ASK carrier Input. (Recommend below 3Vp-p)	←	2.1V by internal bias. (50kΩ)
11	ASK DATA IN	ASK Data Input. (Hi: more than 2V, Lo: below 0.4V)	←	
12	ASK TX Output	ASK modulated signal Output	←	Push-pull output
13	ASK RX Output	ASK Demodulated Output	←	Open collector output ASK carrier detect = Lo
14	ASK DET filter	ASK Detector filter	←	
15	ASK AGC filter /AGC OFF	AGC filter for ASK. (When AGC operate voltage is 0V to 3V, AGC stop when you add over 4.5V.)	←	
16	ASK RX input	ASK Demodulate Input	←	3.3V by internal bias. (34kΩ/66kΩ)
17	Standby control	FM blocks standby control. (FM block operate: over 2V, FM block standby: under 0.4V )	←	
18	DOC-OUT /2nd-Call input	2ND-Call input, 2ND-Call: Low (High: over 2V, Low: under 0.4V)	DOC output (When DO-DET, output is Low)	DEMODO mode: Open collector output.
19	B-GND	Circuit GND	←	
20	FM AGC filter	Emphasis monitor output	FM AGC control filter (AGC-ON:0 to 3V DC, AGC-OFF:4.5V to 5V by external DC voltage.)	MOD mode: Don't connect capacitor.
21	De-emphasis filter	Non connect(Hi-Z)	De-emphasis filter connection pin.	If you don't need, this pin is open.
22	A-GND	Circuit GND	←	
23	De-emphasis output /V-2V select	DFF for V-diff control (ON: over 2V, OFF: under 0.4V)	DE-emphasis output	MOD mode; VD diff. Count select 0V : VD through 2V : VD 1/2 diff
24	Video input	Video signal input. (from outside CCD camera: 1Vp-p).	Video signal input. (from de-emphasis block: 0.5Vp-p).	MOD mode: Maximum video input level is 1.5Vp-p.

# LA72912V

## Pin Description

Pin No.	Pin Name	Description	Equivalent circuit
1	Emphasis filter	<p>Main Emphasis filter pin.</p> <p>Before FM Modulation, make emphasis characteristic at video signal.</p> <p>Emphasis time constant must be matching at de-emphasis time constant.</p> <p>(If you don't need the emphasis, this pin is open.)</p>	
2	V <sub>CC</sub> 5V	V <sub>CC</sub> pin. Supply voltage is 5V DC. Please connect de-coupling capacitor.	
3	FM/Video OUT	<p>Push-Pull output pin.</p> <p>MOD mode: FM carrier output. (1.8Vp-p: R<sub>out</sub>=200Ω)</p> <p>DEMOD mode: Video signal output. (2.0Vp-p: R<sub>out</sub>=1kΩ)</p>	
4	Regulator filter	<p>Internal regulator filter pin.</p> <p>Please connect 0.1μF (C1).</p>	
5	FM/VD input	<p>DEMOD mode: FM signal input.</p> <p>Internal DC bias is 3.3V. Please use capacitor (C1) coupling.</p> <p>MOD mode: VD signal input. Please input VD signal directory.</p> <p>Please consider input impedance.</p>	
6	MOD/DEMOM Control	<p>MOD mode / DEMOD mode setting pin.</p> <p>MOD mode: Please set over 2V DC voltage. (2 to 5V).</p> <p>DEMOM mode: Please set under 0.4V DC voltage. (0 to 0.4V).</p>	
7	TC1(MOD)/ FMAGC monitor Control	<p>MOD mode: TC1 filter pin. Please connect C1.</p> <p>DEMOM mode: FM-AGC monitor on/off control.</p> <p>GND: AGC-monitor ON</p> <p>V<sub>CC</sub>: AGC-monitor OFF</p>	

Continued on next page.



# LA72912V

Continued from preceding page.

Pin No.	Pin Name	Description	Equivalent circuit
8	TC2(DEMOD)/ FMAGC monitor Output	MOD mode: TC2 filter pin. Please connect C1. DEMOD mode: FM-AGC-monitor output	
9	ASK- $V_{CC5V}$	ASK block $V_{CC}$ . Please supply DC 5V with use capacitor for de-coupling.	
10	ASK CAR IN	ASK carrier input Pin. Please connect with capacitor, 2.1V by internal biased.	
11	ASK DATA IN	ASK data input pin. L level is lower than 0.4V H level is more than 2V	
12	ASK TX Output	ASK output pin. Push-pull type output.	
13	ASK RX Output	ASK detect output. Open corrector type output.	
14	ASK DET filter	ASK detect filter. Connect capacitor for reject of ASK AC component.	

Continued on next page.

# LA72912V

Continued from preceding page.

Pin No.	Pin Name	Description	Equivalent circuit
15	ASK AGC filter /AGC OFF	AGC filter pin for ASK. Please connect pull-up resistance to this pin, and do more than 4.5V at voltage of this pin.	
16	ASK RX input	ASK input pin. Please connect with capacitor, 3.3V by internal biased.	
17	Standby control	Standby control pin. FM block standby: under 0.4V DC voltage. (0 to 0.4V) FM block operate: over 2V DC voltage. (2 to 5V)	
18	DOC-OUT /2nd-Call input	DEMODO mode: Drop-out output pin. This pin is open collector output, so please connect pull up resistor. MOD mode: 2ND-CALL input. 2ND-CALL input: under 0.4V DC voltage. (0 to 0.4V) Normal: over 2V DC voltage. (2 to 5V)	
19	B-GND	Circuit GND.	
20	FM AGC filter	MOD mode: Emphasis monitor pin. DEMODO mode: FM AGC filter pin. If FM AGC no need (= AGC Off), Please set pin 12 voltage over 4.5V DC voltage. (4.5 to 5V)	
21	De-emphasis filter	DEMODO mode: De-emphasis filter pin. De-emphasis time constant must be matching at emphasis time constant. (If you don't need the emphasis, this pin is open.)	
22	A-GND	Circuit GND.	

Continued on next page.

# LA72912V

Continued from preceding page.

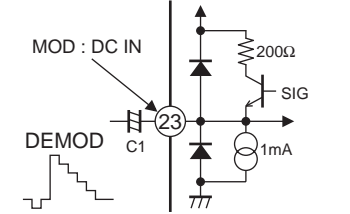
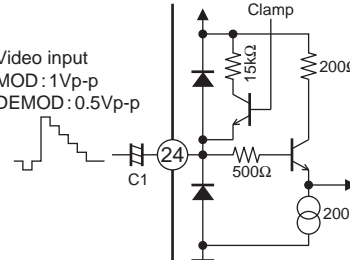
Pin No.	Pin Name	Description	Equivalent circuit
23	De-emphasis output <i>V-2V select</i>	DEMOD mode: Video signal output after De-emphasis. Output level is 0.5Vp-p. Connect capacitor to clamp input (pin 16). MOD mode: DFF control pin. DFF is ON at over 2V DC voltage. (2 to 5V)	 <p>The equivalent circuit for Pin 23 shows a signal input from the left through a capacitor C1. The signal is connected to the base of a transistor. The emitter is grounded. The collector is connected to a 200Ω resistor, which is in series with a diode pointing towards the collector. The other end of the diode is connected to a 1mA current source. The output signal, labeled SIG, is taken from the collector. A second diode is connected from the collector to ground, pointing towards the collector. The circuit is powered by a 777 pin header.</p>
24	Video input	MOD mode: Video signal input pin (from camera). Input level is 1Vp-p. DEMOD mode: Video signal input pin (from de-emphasis). Input level is 0.5Vp-p.	 <p>The equivalent circuit for Pin 24 shows a video input signal from the left through a capacitor C1. The signal is connected to the base of a transistor. The emitter is grounded. The collector is connected to a 500Ω resistor, which is in series with a diode pointing towards the collector. The other end of the diode is connected to a 200μA current source. The output signal is taken from the collector. A second diode is connected from the collector to ground, pointing towards the collector. The circuit is powered by a 777 pin header. A clamp circuit is shown, consisting of a 15kΩ resistor and a 200Ω resistor connected to the collector.</p>

# LA72912V

## Test Circuit

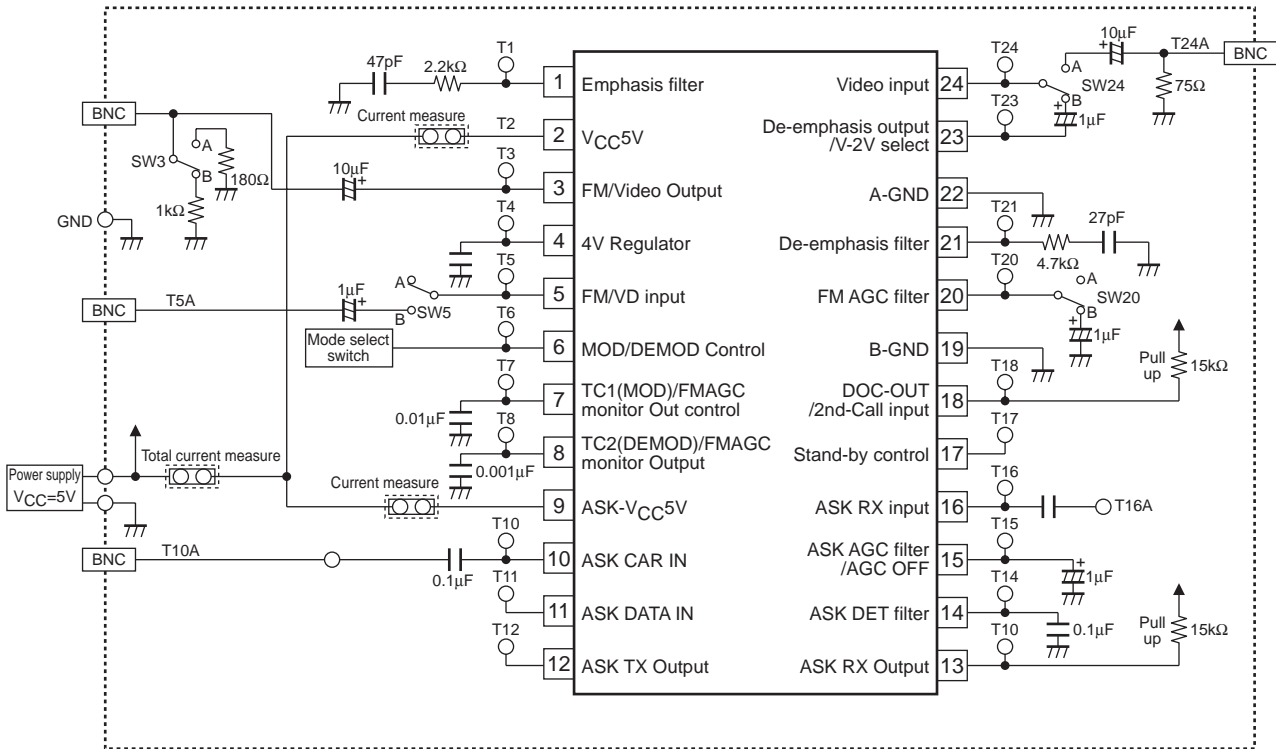

ON Semiconductor and the ON logo are registered trademarks of Semiconductor Components Industries, LLC (SCILLC). SCILLC owns the rights to a number of patents, trademarks, copyrights, trade secrets, and other intellectual property. A listing of SCILLC's product/patent coverage may be accessed at [www.onsemi.com/site/pdf/Patent-Marking.pdf](http://www.onsemi.com/site/pdf/Patent-Marking.pdf). SCILLC reserves the right to make changes without further notice to any products herein. SCILLC makes no warranty, representation or guarantee regarding the suitability of its products for any particular purpose, nor does SCILLC assume any liability arising out of the application or use of any product or circuit, and specifically disclaims any and all liability, including without limitation special, consequential or incidental damages. "Typical" parameters which may be provided in SCILLC data sheets and/or specifications can and do vary in different applications and actual performance may vary over time. All operating parameters, including "Typicals" must be validated for each customer application by customer's technical experts. SCILLC does not convey any license under its patent rights nor the rights of others. SCILLC products are not designed, intended, or authorized for use as components in systems intended for surgical implant into the body, or other applications intended to support or sustain life, or for any other application in which the failure of the SCILLC product could create a situation where personal injury or death may occur. Should Buyer purchase or use SCILLC products for any such unintended or unauthorized application, Buyer shall indemnify and hold SCILLC and its officers, employees, subsidiaries, affiliates, and distributors harmless against all claims, costs, damages, and expenses, and reasonable attorney fees arising out of, directly or indirectly, any claim of personal injury or death associated with such unintended or unauthorized use, even if such claim alleges that SCILLC was negligent regarding the design or manufacture of the part. SCILLC is an Equal Opportunity/Affirmative Action Employer. This literature is subject to all applicable copyright laws and is not for resale in any manner.



Компания «ЭлектроПласт» предлагает заключение долгосрочных отношений при поставках импортных электронных компонентов на взаимовыгодных условиях!

Наши преимущества:

- Оперативные поставки широкого спектра электронных компонентов отечественного и импортного производства напрямую от производителей и с крупнейших мировых складов;
- Поставка более 17-ти миллионов наименований электронных компонентов;
- Поставка сложных, дефицитных, либо снятых с производства позиций;
- Оперативные сроки поставки под заказ (от 5 рабочих дней);
- Экспресс доставка в любую точку России;
- Техническая поддержка проекта, помощь в подборе аналогов, поставка прототипов;
- Система менеджмента качества сертифицирована по Международному стандарту ISO 9001;
- Лицензия ФСБ на осуществление работ с использованием сведений, составляющих государственную тайну;
- Поставка специализированных компонентов (Xilinx, Altera, Analog Devices, Intersil, Interpoint, Microsemi, Aeroflex, Peregrine, Syfer, Eurofarad, Texas Instrument, Miteq, Cobham, E2V, MA-COM, Hittite, Mini-Circuits, General Dynamics и др.);

Помимо этого, одним из направлений компании «ЭлектроПласт» является направление «Источники питания». Мы предлагаем Вам помощь Конструкторского отдела:

- Подбор оптимального решения, техническое обоснование при выборе компонента;
- Подбор аналогов;
- Консультации по применению компонента;
- Поставка образцов и прототипов;
- Техническая поддержка проекта;
- Защита от снятия компонента с производства.



#### Как с нами связаться

**Телефон:** 8 (812) 309 58 32 (многоканальный)

**Факс:** 8 (812) 320-02-42

**Электронная почта:** [org@eplast1.ru](mailto:org@eplast1.ru)

**Адрес:** 198099, г. Санкт-Петербург, ул. Калинина, дом 2, корпус 4, литера А.