

NFC Forum Type 4 Tag IC with up to 2-Kbit EEPROM

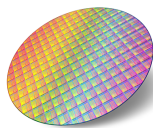

UFD5FN5
(1.7x1.4mm)



Wafer



Features

Contactless interface

- NFC Forum Type 4 Tag, certified by the NFC Forum
- ISO/IEC 14443 Type A
- 106 kbps data rate
- Internal tuning capacitance: 50 pF

Memory

- Up to 256-byte (2-Kbit) EEPROM
- Support NDEF data structure
- Data retention: 200 years
- Endurance: 1 million erase-write cycles
- Read up to 256 bytes in a single command
- Write up to 54 bytes in a single command
- Chaining capability
- 7-byte unique identifier (UID)
- 128-bit password protection
- 20-bit event counter with anti-tearing

Product identification and protection

- TruST25™ digital signature

Package

- UFD5FN5 ECOPACK®2

Digital output

- GPO: configurable general purpose output
 - driven by an open drain transistor, available on ST25TA02KB-D only
 - enabling no DC consumption (CMOS output buffer), available on ST25TA02KB-P only.

Description

The ST25TA512B and ST25TA02KB devices are NFC tag ICs, with an optional general purpose output available on ST25TA02KB-D and ST25TA02KB-P.

They embed an up to 2 -Kbit EEPROM, and can be operated from a 13.56 MHz RFID reader or an NFC phone.

The ST25TA512B, ST25TA02KB,

ST25TA02KB-D and ST25TA02KB-P devices are NFC Forum Type 4 Tags.

They communicate using the ISO/IEC 14443 Type A protocol, and feature a digital signature generated by TruST25™ (a set of software and procedures) used to prove the origin of the chip in cloning detection.

Product status link
ST25TA512B
ST25TA02KB
ST25TA02KB-D
ST25TA02KB-P

1 Functional description

The **ST25TA512B**, **ST25TA02KB**, **ST25TA02KB-D** and **ST25TA02KB-P** (hereinafter referred to as **ST25TxxxB**) devices are NFC tags that can be accessed from the RF interface, based on the ISO/IEC 14443 Type A standard. The **ST25TxxxB** are compatible with the NFC Forum Type 4 Tag specifications and support all corresponding commands.

Figure 1, **Figure 2** and **Figure 3** show the block diagram, respectively, of the **ST25TA02KB/ST25TA512B**, **ST25TA02KB-D** and **ST25TA02KB-P** devices.

Figure 1. Block diagram - ST25TA02KB and ST25TA512B

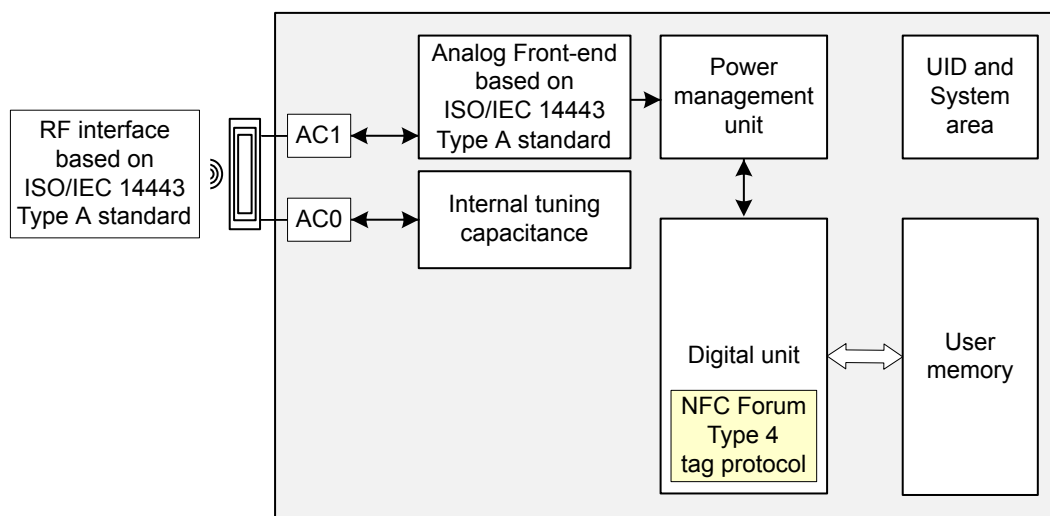

Figure 2. Block diagram - ST25TA02KB-P

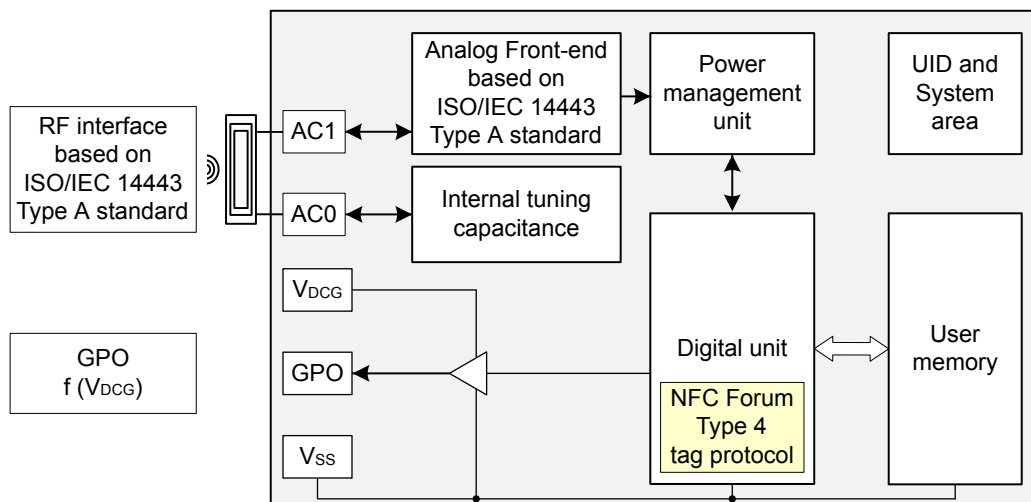
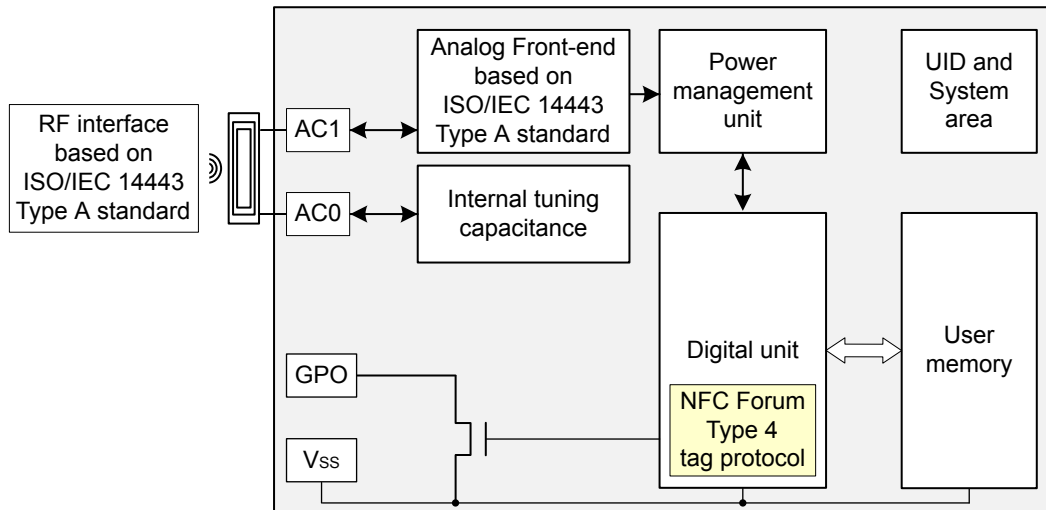
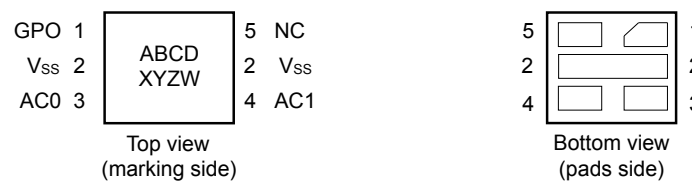

Figure 3. Block diagram - ST25TA02KB-D

Table 1. Signal names

Signal name	Function	Direction
AC0, AC1	Antenna coils	-
V _{DCG} ⁽¹⁾	Supply voltage for CMOS GPO driver	Power
V _{SS} ⁽²⁾	Ground	-
GPO ⁽²⁾	Interrupt output	CMOS or Open drain output

1. Only available on ST25TA02KB-P.
2. Only available on ST25TA02KB-P and ST25TA02KB-D.

Figure 4. 5-pin package connections - ST25TA02KB-D

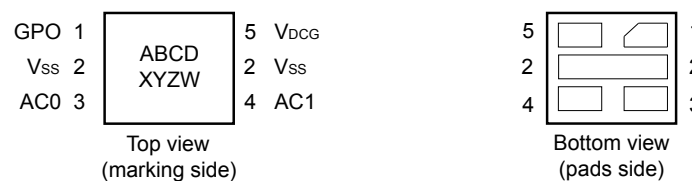
1. See Section 13 Package information for package dimensions, and how to identify pin 1.

Figure 5. 5-pin package connections - ST25TA02KB-P

1. See Section 13 Package information for package dimensions, and how to identify pin 1.

1.1 Functional mode

The ST25TxxxxB have only one functional mode available (see [Table 2](#)).

Table 2. Functional mode

Mode	Supply source	Comments
Tag mode	RF field only	The RF interface operates only when RF field level is sufficient.

The optional GPO open drain transistor requests an external pull-up ($> 4.7\text{ k}\Omega$) to operate (see [Figure 6](#)).

Figure 6. Applicative example of GPO usage - ST25TA02KB-D

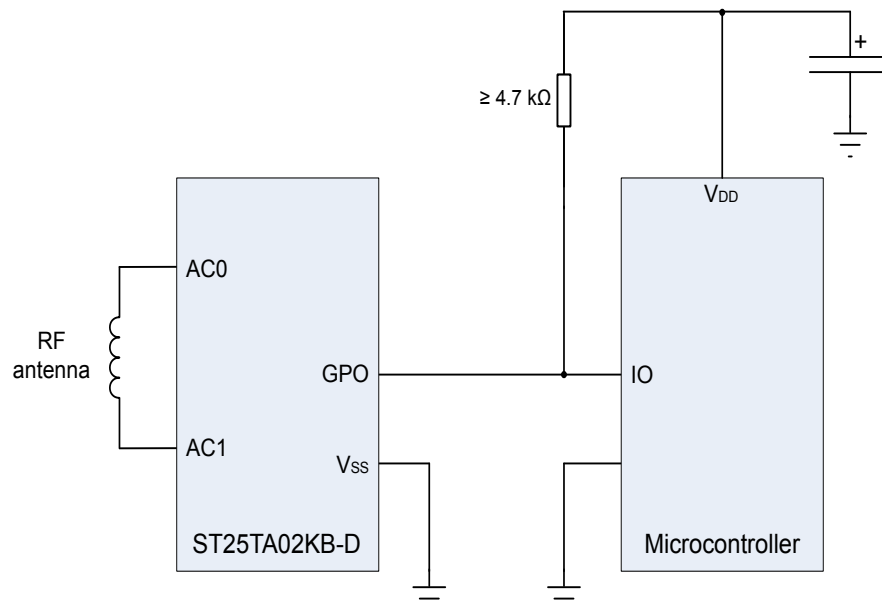

The optional GPO CMOS driver requests an external supply to operate (see [Figure 7](#)).

Figure 7. Applicative example of GPO usage - ST25TA02KB-P

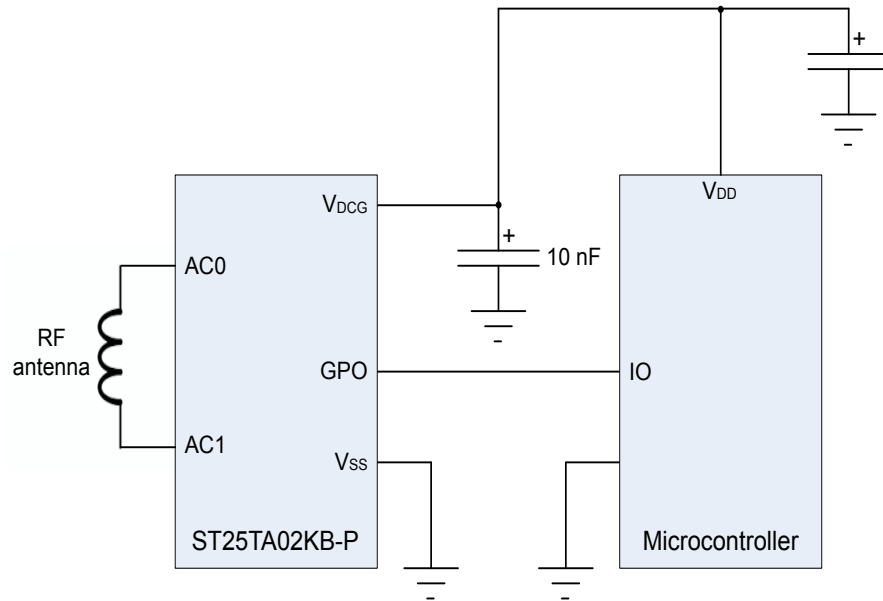

1.1.1 Tag mode

The ST25TxxxB are supplied by the RF field and can communicate with an RF host (RFID reader or NFC phone). The User memory can be accessed by the RF commands.

2 Signal description

2.1 Antenna coil (AC0, AC1)

These inputs are used to connect the ST25TAxxx devices to an external coil exclusively. It is advised not to connect any other DC or AC path to neither AC0 nor AC1.

When correctly tuned, the coil is used to access the devices using NFC Forum Type 4 commands.

2.2 Ground (V_{SS}), only available on ST25TA02KB-P and ST25TA02KB-D

V_{SS} , when connected, is the reference for the V_{DCG} supply voltage and for all pads, including AC0 and AC1.

2.3 GPO supply voltage (V_{DCG}), only available on ST25TA02KB-P

This pin can be connected to an external DC supply voltage. It only supplies the GPO driver block.

2.3.1 Operating supply voltage V_{DCG}

Before checking ST25TA02KB-P GPO, a valid and stable V_{DCG} voltage within the specified [$V_{DCG(min)}$, $V_{DCG(max)}$] range must be applied.

To maintain a stable DC supply voltage, it is recommended to decouple the V_{DCG} line with suitable capacitors (usually of the order of 10 nF and 100 pF) close to the V_{DCG} / V_{SS} package pins.

This voltage must remain stable and valid until the end of the GPO usage by the ST25TA02KB-P.

2.3.2 Power-up conditions

The V_{DCG} rise time must not vary faster than 1 V / μ s.

2.4 General purpose output (GPO), only available on ST25TA02KB-P and ST25TA02KB-D

The GPO pad is either an open drain pad on which an external pull-up resistor shall be connected, or a CMOS pad with default polarity set to 0.

This pad is a configurable output signal, driven to active level when configured events occur. Its behavior is consistent with the RF session activated and with the mode chosen by the user, see [Section 7 Functional procedures](#) for more details.

3 ST25TAxxxB memory management

3.1 Memory structure

The ST25TAxxxB support the NDEF Tag Application as defined in the NFC Forum Type 4 Tag. They are composed of three files:

- a Capability Container (CC) file
- an NDEF file
- a System file: this file is an ST-proprietary file

The System file contains some information on the configuration of the ST25TAxxxB devices. The CC file gives some information about the ST25TAxxxB and the NDEF file. The NDEF file contains the User data.

3.1.1 File identifier

The file identifier is the value used in the Select command to select a file.

Table 3. File identifier

File identifier	Meaning
0xE101	System file
0xE103	CC file
0x0001	NDEF file

3.1.2 CC file layout

The CC file gives some information about the ST25TAxxxB and the NDEF file. This file is a read-only file for the RF host and cannot be modified by issuing a write command.

The T field, Read Access and Write Access fields can be changed by the RF host by issuing a specific process (refer to [Section 7 Functional procedures](#)).

Table 4. CC file layout

File offset	Meaning	Value	Comments
0x0000	Length CC file	0x000F	15 bytes
0x0002	Mapping version ⁽¹⁾	0x20 or 0x10	V 2.0 or V 1.0
0x0003	MLe: Maximum number of bytes that can be read	0x00FF ⁽²⁾	255 bytes ⁽²⁾
		0x0040 ⁽³⁾	64 bytes ⁽³⁾
0x0005	MLc: Maximum number of bytes that can be written	0x0036	54 bytes
0x0007	NDEF file control TLV	0x04 ⁽⁴⁾	T field
0x0008		0x06	L field
0x0009		0x0001	FileID
0x000B		0x0100 ⁽²⁾	FLEN: Maximum NDEF file size in Bytes
		0x0040 ⁽³⁾	
0x000D		0x00 ⁽⁴⁾	CCRD: Read access condition
0x000E		0x00 ⁽⁴⁾	CCWR: Write access condition

1. According to the reader command format the ST25TAxxxB devices will automatically align to the corresponding NFC Forum version.

2. ST25TA02KB, ST25TA02KB-D and ST25TA02KB-P.

3. *ST25TA512B.*
4. *Delivery state.*

3.1.3 NDEF file layout

The NDEF file contains the NDEF message that contains the User data. The RF host can read and write data inside the file. The first two bytes named NDEF Message Length define the size of the NDEF message. The NDEF Message Length shall be managed by the application and the ST25TAxxxB devices do not check if its value is relevant vs. the data written by the RF host. If the NDEF Message Length value stored in the file is greater than FLEN-2 (NDEF Message Length > FLEN-2 can occur because of a successful UpdateBinary command with wrong value, or because of a corrupted UpdateBinary command.) the tag handles it as an invalid case and returns 0x00 for the byte values at offsets 0x0000 and 0x0001 in the response to a ReadBinary command.

For more details about the read command, refer to [Section 6.7.5 ReadBinary command](#)

Table 5. NDEF file layout

File offset	Byte 0	Byte 1	Byte 2	Byte 3
0x0000	NDEF Message Length		User data	User data
0x0004	User data	User data	User data	User data
...
...
...
0x00FC ⁽¹⁾ or 0x003C ⁽²⁾	User data

1. *ST25TA02KB, ST25TA02KB-D and ST25TA02KB-P.*
2. *ST25TA512B.*

3.1.4 System file layout

The system file specifies the configuration of the ST25TxxxB devices. [Table 6](#) lists the different fields.

Table 6. Field list

File offset	Field name	No. of bytes	Read access	Write access	Device(s)	Delivery state
0x0000	Length system file	2	Yes	-	ST25TA512B ST25TA02KB ST25TA02KB-D ST25TA02KB-P	0x0012
0x0002	ST reserved	1	Yes	None	ST25TA512B ST25TA02KB	0x80
	GPO Config			Yes ⁽¹⁾	ST25TA02KB-D ST25TA02KB-P	0x70 ⁽²⁾
0x0003	Event Counter Config	1	Yes	Yes ⁽¹⁾	ST25TA512B	0x00
0x0004	20-bit counter (MS nibble 0x0)	3	Yes	None	ST25TA02KB ST25TA02KB-D	0x000000
0x0007	Product version	1	Yes	None	ST25TA02KB-P	0x22 ⁽³⁾
0x0008	UID	7	Yes	None	ST25TA512B	0x02E4 xx xx xx xx xx ⁽⁴⁾
					ST25TA02KB	0x02E3 xx xx xx xx xx ⁽⁴⁾
					ST25TA02KB-D	0x02F3 xx xx xx xx xx ⁽⁴⁾
					ST25TA02KB-P	0x02A3 xx xx xx xx xx ⁽⁴⁾
0x000F	Memory Size - 1	2	Yes	None	ST25TA512B	0x003F
					ST25TA02KB	0x00FF
					ST25TA02KB-D	
					ST25TA02KB-P	
0x0011	IC reference code	1	Yes	None	ST25TA512B	0xE5
					ST25TA02KB	0xE2
					ST25TA02KB-D	0xF2
					ST25TA02KB-P	0xA2

1. Configuration bytes can be locked by setting the Most significant bit to 1. Once locked, these bytes cannot be changed anymore.

2. Field detect as GPO configuration.

3. ST reserved.

4. x values are defined by ST to ensure UID uniqueness.

Table 7. Details about the Counter configuration field

File offset	b7	b6-b2	b1	b0
0x0003				
Counter configuration lock bit:				
<ul style="list-style-type: none"> • 0b0: unlocked • 0b1: locked 				
0b00000 (ST reserved)				
Counter enable:				
<ul style="list-style-type: none"> • 0b0: disable • 0b1: enable 				
Counter increment:				
<ul style="list-style-type: none"> • 0b0: on Read • 0b1: on Write 				

Table 8. Details about the GPO field

File offset	b7	b6-b4	b3-b0
0x0002			
GPO configuration lock bit:			
<ul style="list-style-type: none"> • 0b0: unlocked • 0b1: locked 			
GPO configuration:			
<ul style="list-style-type: none"> • 0b000: Not used • 0b001: Session opened • 0b010: WIP • 0b011: MIP • 0b100: Interrupt • 0b101: State Control • 0b110: RF Busy • 0b111: Field Detect 			
0b0000			
(ST reserved)			

3.2 Read and write access rights to the NDEF file

The NDEF file can be protected for read or write accesses with passwords that the host shall present before accessing the NDEF file. There are two 128-bit passwords, one for the read access and the other one for the write access.

An NDEF file can also be locked for read or write accesses. Thus, the host cannot access the NDEF file.

The read password shall be sent to the ST25TAXxxB devices before reading a read-protected NDEF file.

The write password shall be sent to the ST25TAXxxB devices before writing a write-protected NDEF file. The write password shall be sent to change the read or write protection mode. The access rights are only relevant for the NDEF file. If the Verify command is used with the CC, System or no file selected, an error is responded by the tag.

3.2.1 Read and Write protection modes

Three protection modes are defined for each of the Read and Write access rights to the NDEF file:

- UNPROTECTED
- PROTECTED
- FORBIDDEN

The Read/Write protection mode is identified by the R-APDU value responded to a Verify command (see [Section 6.8.1 Verify command](#)).

Table 9. Read protection modes

Mode	Verify (P1P2=0x0001) R-APDU	Meaning
READ UNPROTECTED	0x9000	Read access without any security (delivery state)
READ PROTECTED	0x6300	Read access protected by password
READ FORBIDDEN	0x6984	Read access forbidden (permanent state)

Table 10. Write protection modes

Mode	Verify (P1P2=0x0002) R-APDU	Meaning
WRITE UNPROTECTED	0x9000	Write access without any security (delivery state)
WRITE PROTECTED	0x6300	Write access protected by password
WRITE FORBIDDEN	0x6984	Write access forbidden (permanent state)

3.2.2 Read and Write access conditions

The CCRD and CCWR bytes (see [Table 3. File identifier](#)) in the CC file are used to identify the Read and Write access conditions for the NDEF message as defined in the NFC Forum Type 4 Tag specification. The ST25TAXxB support one read condition value and two write condition values.

[Table 11](#) and [Table 12](#) show how these condition values are mapped to the read and write protection modes defined in [Section 3.2.1 Read and Write protection modes](#).

Caution: As several protection modes may be mapped to a single condition value, the Read and Write access condition values are not to be used to identify the protection modes.

Table 11. Read access conditions (CCRD values)

Value	Read protection modes
0x00	UNPROTECTED, PROTECTED, FORBIDDEN ⁽¹⁾

1. Refer to [Section 3.2.1 Read and Write protection modes](#) to discriminate between the protection modes.

Table 12. Write access conditions (CCWR values)

Value	Write protection modes
0x00	UNPROTECTED
0xFF	PROTECTED, FORBIDDEN ⁽¹⁾

1. Refer to [Section 3.2.1 Read and Write protection modes](#) to discriminate between the protection modes.

3.2.3 Changing the read protection mode

The state diagram of Figure 8 shows how to change the read protection mode of the NDEF file.

Figure 8. Changing the read protection mode

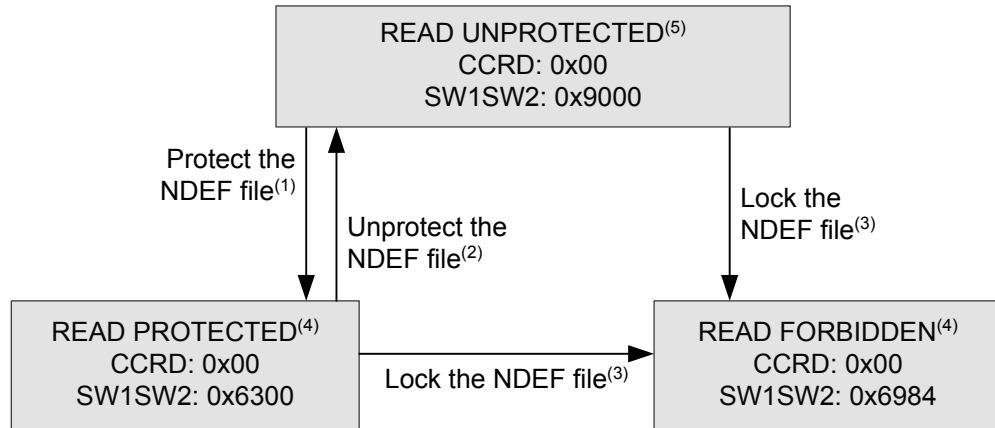

CCRD: byte at offset 0x000D in the CC file
SW1SW2: response to the Verify (Read protection) command

1. See the procedure to protect the read access (Section 7.1 Protecting an NDEF file).
2. See the procedure to unprotect the read access (Section 7.3 Unprotecting an NDEF file).
3. See the procedure to forbid the read access (Section 7.4 Locking an NDEF file).
4. Proprietary state, not defined by NFC Forum Type 4 Tag.
5. Delivery state.

3.2.4 Changing the write protection mode

The state diagram of Figure 9 shows how to change the write protection mode of the NDEF file.

Figure 9. Changing the write protection mode

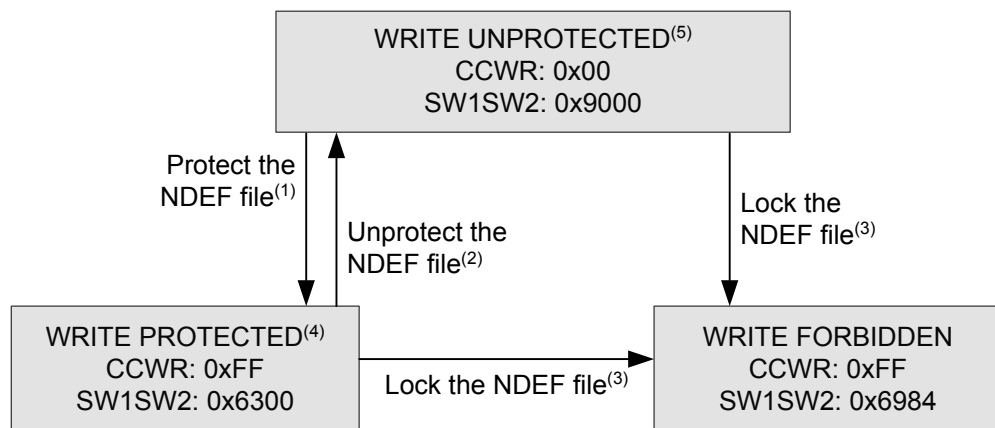

CCWR: byte at offset 0x000E in the CC file
SW1SW2: response to the Verify (Write protection) command

1. See the procedure to protect the write access (Section 7.1 Protecting an NDEF file).
2. See the procedure to unprotect the write access (Section 7.3 Unprotecting an NDEF file).

3. See the procedure to forbid the write access ([Section 7.4 Locking an NDEF file](#)).
4. Proprietary state, not defined by NFC Forum Type 4 Tag.
5. Delivery state.

3.3 Granted access life time

When the NDEF file is in a READ or WRITE PROTECTED state, the corresponding file access is granted starting from the first successful password presentation (see [Section 7.1 Protecting an NDEF file](#)), and until one of the following events occurs:

- an RF field shutdown
- a successful DESELECT command
- a successful NDEF Tag Application Select command (no file selected)
- successful Capability Container Select or System File Select command (other file selected)
- a wrong password presentation (security session closed)

When the NDEF file is in a READ or WRITE FORBIDDEN state, the corresponding file access is never granted.

3.4 NDEF file passwords

Two passwords are available on the ST25TxxxB devices:

- Read password: protects the read access to the NDEF file
- Write password: protect the write access to the NDEF file and the setting of the read and write protection modes (see [Section 7.1 Protecting an NDEF file](#) and [Section 7.2 Accessing a protected NDEF file](#))

The length of a password is 128 bits (16 bytes).

A password is presented using the Verify command (see [Section 6.8.1 Verify command](#)).

After three consecutive authentication failures for a given password, further attempts will fail until the following sequence of events occurs:

- tag set in Standby power mode (RF field shutdown or DESELECT command)
- tag activation (anticollision and RATS commands)
- successful NDEF Tag Application Select command
- successful NDEF Select command

Note: The delivery state for all passwords is 0x00000000000000000000000000000000.

4 Specific features

4.1 Read/Write counter

A 20-bit counter can track the read or write events on the NDEF file.

It benefits from an anti-tearing mechanism, that ensures the consistency of the counter, even if there has been an electrical problem during its increment.

The value of the Read/Write counter can be checked by any application, by reading suitable bytes in System file (see [Section 3.1.4 System file layout](#)).

If enabled, the Read/Write counter will be incremented on the first event (exclusively read / write) performed on the NDEF File, after a successful NDEF Tag Application Select command. Following read/write events will not modify the counter value until a new successful NDEF Tag Application Select command is issued.

The counter is reset when it is disabled.

Apart from these procedures, there is no way to act on the value of this counter.

The Read/Write counter can be configured through a specific byte in System file (see [Section 3.1.4 System file layout](#)).

This configuration byte allows to:

- Enable or disable this counter
- Define if the counter must be incremented on a read or write sequence
- Definitively lock this configuration byte

Caution: Once this configuration byte is locked, it cannot be changed anymore: the counter will behave accordingly.

If enabled, the Read/Write counter will have an impact on the execution time of the event being countered: the counter increment needs some write cycles of specific EEPROM cells automatically managed by ST25TxxxB, this increases the total time before the response is sent to the reader.

As a consequence, an S(WTX) request can be issued on the command that will increment the counter (see [Section 6.4 S-Block format](#)).

4.2 General purpose output (GPO), only available on ST25TA02KB-D/P

The GPO pad is either a CMOS pad (ST25TA02KB-P) or an open drain pad (ST25TA02KB-D).

In case of CMOS GPO active state is 1 and inactive state is 0.

In case of open drain an external pull-up shall be connected to it. In this case, active state is 0 and inactive state is 1. If no pull-up is used the active state is 0, but inactive state is HZ.

This pad is a configurable output signal, driven to the alternate polarity when configured event occur. Its behavior is consistent with the RF session activated and with the mode chosen by the user.

The user can select one of these configurations ([Table 68. GPO timings measurement](#)):

- Inactive: the state of the GPO pad is always inactive
- SessionOpen: an RF session is ongoing.
- MIP (NDEF Message updating In Progress): the RF host is writing an NDEF length different from 0x0000. This mode can be used to detect when the RF host changes the NDEF message as defined by the NFC Forum.
- WIP (Writing In Progress): the ST25TA02KB-D/P is executing a writing operation.
- INT (interrupt): the RF host can force the ST25TA02KB-D/P to send an alternate pulse on the GPO pin.
- State mode: the RF host can control the state of the GPO pad during the RF session.
- RF busy: an RF host is communicating with the ST25TA02KB-D/P.
- Field detection: the RF field is sufficient to establish an RF communication with the ST25TA02KB-D/P.

GPO configuration byte can be locked, by setting its Most Significant Bit to 1 (1xxx 0000 b). Once locked, this byte cannot be changed anymore.

4.2.1 Inactive configuration (GPO field = 0x00 or 0x80)

When the GPO is configured as "Inactive", it remains in inactive state regardless of the events on the RF interface (except setting the GPO to another configuration).

4.2.2 Session Open configuration (GPO field = 0x10 or 0x90)

When the GPO is configured as "Session Open", it goes to the active state when an RF session is ongoing (see Figure 10 or Figure 11).

An RF session is taken when the ST25TA02KB-D/P receives a valid Select Application. The session is released when:

- ST25TA02KB-D/P receives a valid Deselect command
- RF field becomes OFF

GPO is driven to active state after a delay (1.) when the session is open.

GPO is released after a delay (2.) when the session is released.

Figure 10. CMOS GPO configured as Session Open (GPO field = 0x10 or 0x90)

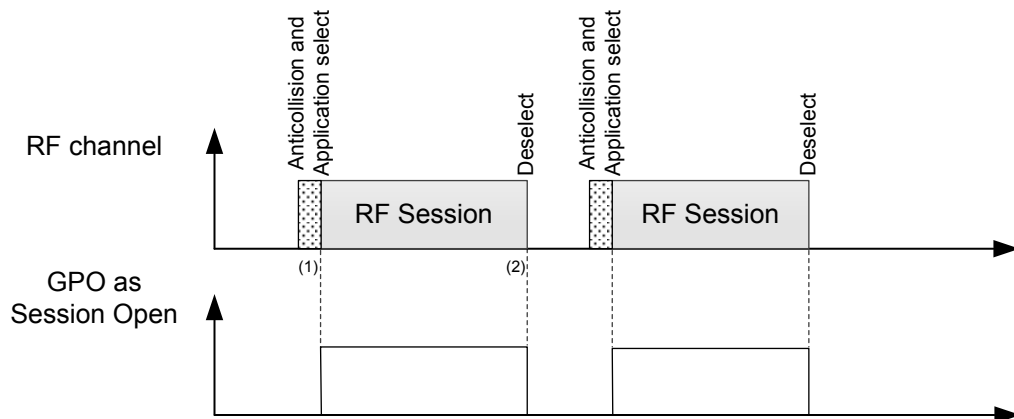

1. CmdEOFtoGPhigh (RF command End of frame to GPORF Session pad high).
2. CmdEOFtoGPlow (RF command End of frame to GPORF Session pad low).

Figure 11. Open drain GPO configured as Session Open (GPO field = 0x10 or 0x90)

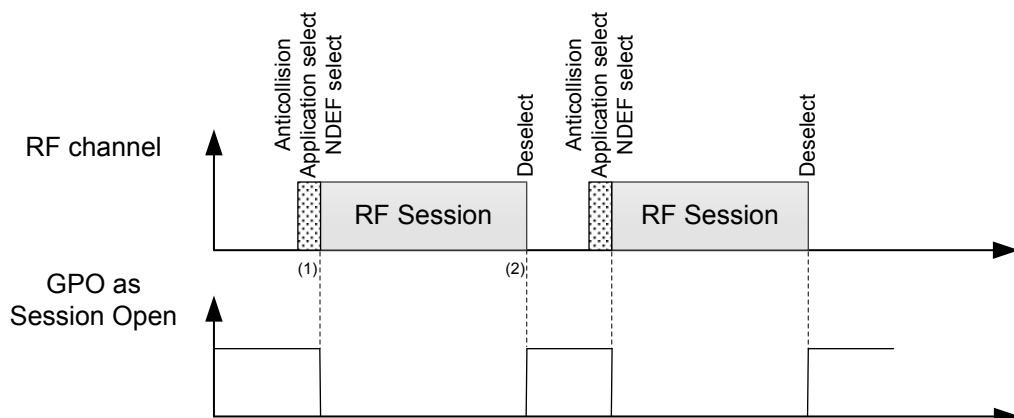

1. CmdEOFtoGPlow (RF command End of frame to GPORF Session pad low).
2. CmdEOFtoGPHZ (RF command End of frame to GPORF Session pad HZ).

4.2.3 WIP Writing in Progress configuration (GPO field = 0x20 or 0xA0)

When the GPO is configured as “WIP”, it goes to the active state during an RF writing operation (see Figure 12 or Figure 13).

During an RF session, when the ST25TA02KB-D/P updates a file, the GPO is driven in active state after a delay (1.) following the beginning of the correspondent UpdateBinary command execution.

GPO will remain in active state during the writing time (2.), before being released.

Figure 12. CMOS GPO configured as WIP (GPO field = 0x20 or 0xA0)

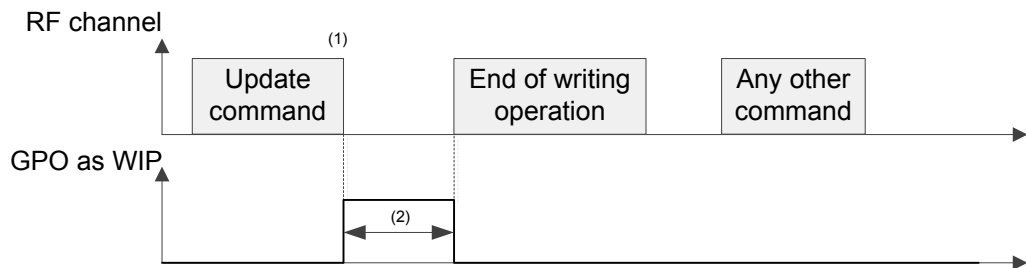

1. CmdEOFtoGPhigh (RF Command End of frame to GPO high).
2. Writing time duration.

Figure 13. Open drain GPO configured as WIP (GPO field = 0x20 or 0xA0)

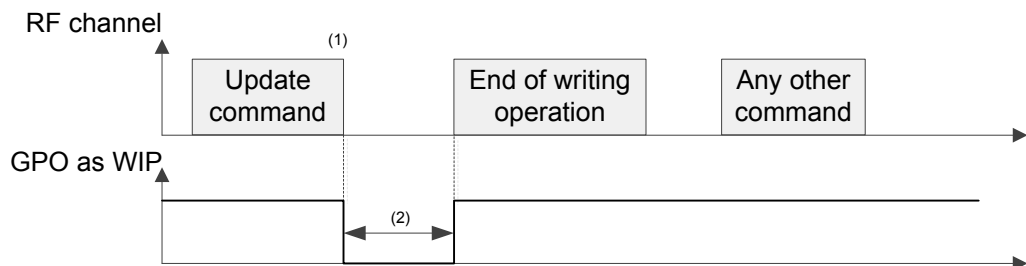

1. CmdEOFtoGPlow (RF Command End of frame to GPO low).
2. Writing time duration.

4.2.4 MIP NDEF Message writing in Progress configuration (GPO field = 0x30 or 0xB0)

When the GPO is configured as MIP, its state goes to the active state when the RF host writes the NDEF length to another value than 0x0000 (see [Figure 14](#) or [Figure 15](#)).

During an RF session, when the ST25TA02KB-D/P changes an NDEF file and updates the NDEF length with a value different from 0x0000, the GPO is driven in active state after a delay (1.) following the beginning of the correspondent UpdateBinary command execution.

GPO will remain in active state during the writing time (2.), before being released.

Figure 14. CMOS GPO configured as MIP (GPO field = 0x30 or 0xB0)

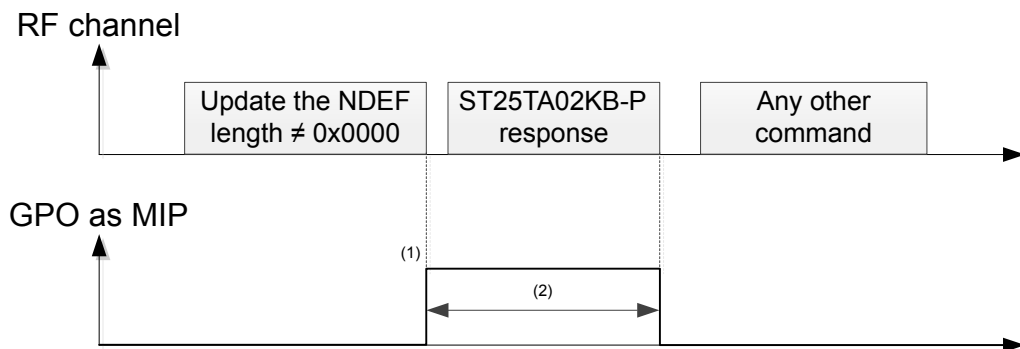

1. CmdEOFtoGPhigh (RF command End of frame to GPO high).
2. Writing time duration.

Figure 15. Open drain GPO configured as MIP (GPO field = 0x30 or 0xB0)

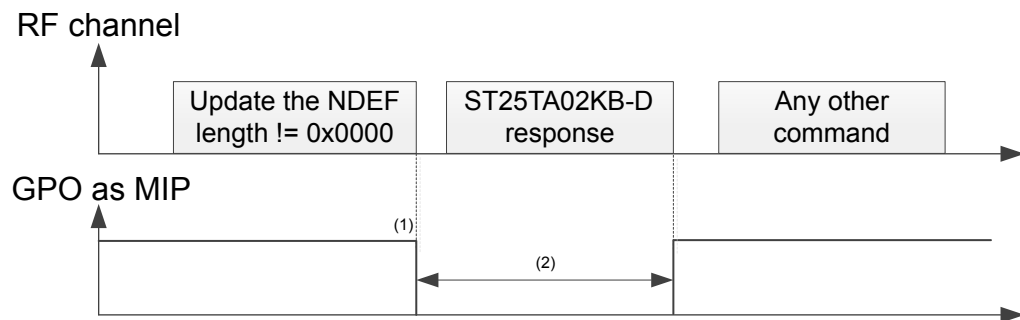

1. CmdEOFtoGPlow (RF command End of frame to GPO low).
2. Writing time duration.

4.2.5 INT Interrupt configuration (GPO field = 0x40 or 0xC0)

The RF host can send a pulse on the GPO pad. The GPO pad goes to active state at the end of the command and goes to the inactive state at the end of the ST25TA02KB-D/P response (see Figure 16 or Figure 17).

During an RF session, when the ST25TA02KB-D/P receives a valid SendInterrupt command, the GPO pin is driven in active state (1.). Then the GPO pin is released at the end of the response (2.).

Figure 16. CMOS GPO configured as INT (GPO field = 0x40 or 0xC0)

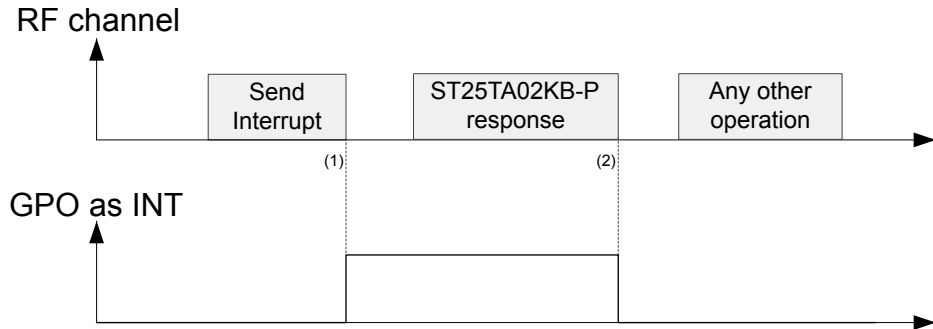

1. CmdEOFtoGPhigh (RF command End of frame to GPO high).
2. RespEOFtoGPlow.

Figure 17. Open drain GPO configured as INT (GPO field = 0x40 or 0xC0)

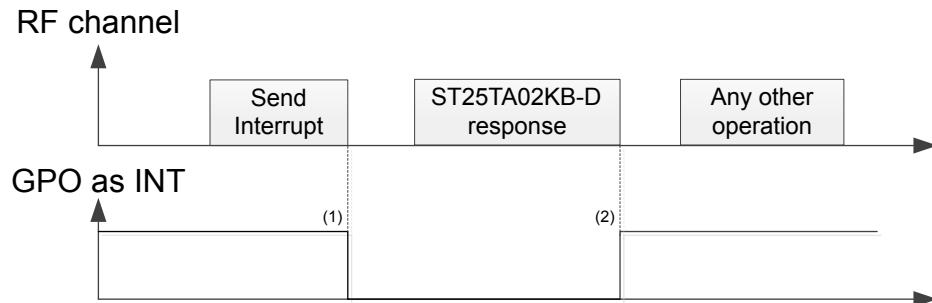

4.2.6 State Control configuration (GPO field = 0x50 or 0xD0)

When the GPO is configured as State Control, the RF host can control the state of the GPO by sending a dedicated command (see Figure 18 or Figure 19).

During an RF session, the ST25TA02KB-D/P can control the GPO pin. After receiving a valid StateControl command with Data=0x00, the GPO pin is driven in active state after a delay (1.). The GPO will be released after a valid StateControl command with Data=0x01 or after a Power off.

Figure 18. CMOS GPO configured as State Control (GPO field = 0x50 or 0xD0)

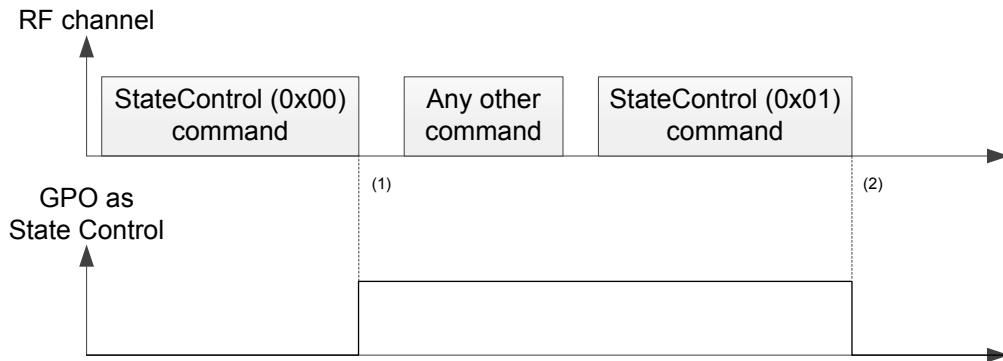

1. CmdEOFtoGPhigh (RF Reset GPO command End of frame to GPO high).
2. CmdEOFtoGPlow (RF Set GPO command End of frame to GPO low).

Figure 19. Open drain GPO configured as State Control (GPO field = 0x50 or 0xD0)

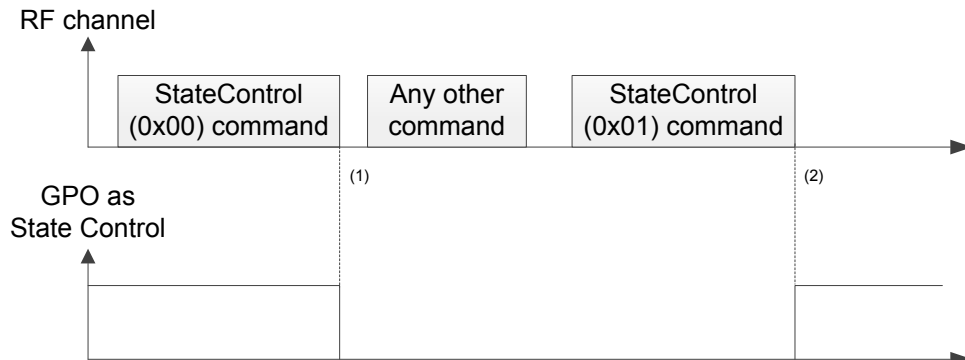

1. CmdEOFtoGPlow (RF Reset GPO command End of frame to GPO low).
2. CmdEOFtoGPHZ (RF Set GPO command End of frame to GPO HZ).

4.2.7 RF busy configuration (GPO field = 0x60 or 0xE0)

When the GPO is configured as RF busy, the GPO goes to the active state, both when the ST25TA02KB-D/P is processing an RF command or when an RF session is ongoing (see Figure 20 or Figure 21).

When an RF field is present, the GPO is driven in active state after a delay (1.) when the ST25TA02KB-D/P detects the first command. If the RF session is ongoing and the ST25TA02KB-D/P receives a not-supported command, GPO remains active. It will be released only at the end of the RF session, after (2.).

Figure 20. CMOS GPO configured as RF busy (GPO field = 0x60 or 0xE0)

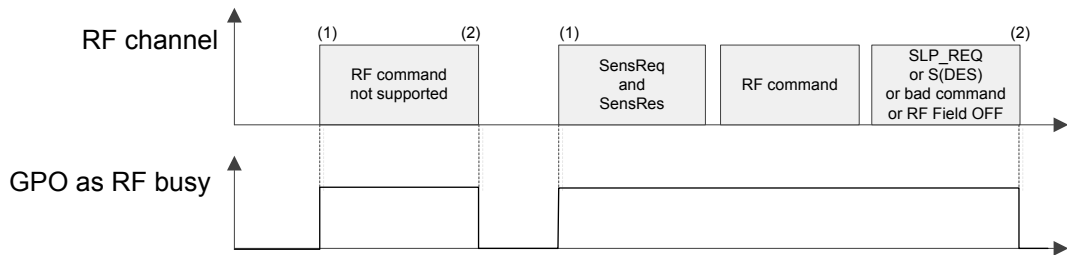

1. CmdSOtoGPhigh (RF command Start of frame to GPO high).
2. CmdEOFtoGPlow (RF command End of frame to GPO low).

Figure 21. Open drain GPO configured as RF busy (GPO field = 0x60 or 0xE0)

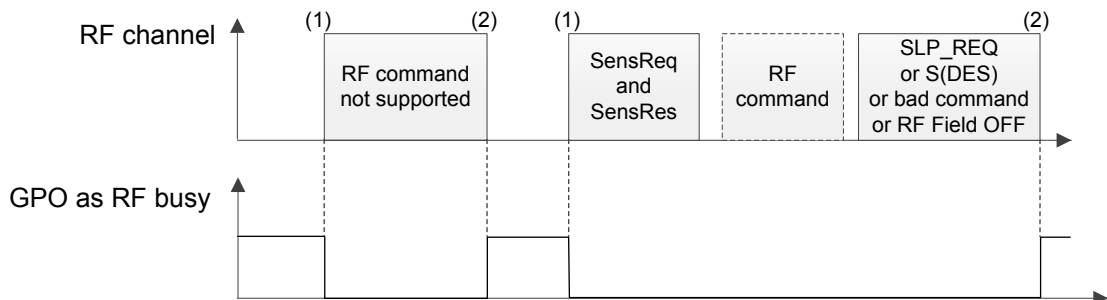

1. CmdSOtoGPlow (RF command Start of frame to GPO low).
2. CmdEOFtoGPHZ (RF command End of frame to GPO HZ).

4.2.8 Field detect configuration (GPO field = 0x70 or 0xF0)

When the GPO is configured as Field detect, the GPO goes to the active state when ST25TA02KB-D/P detects an RF Field (see Figure 22 or Figure 23).

When an RF field is present, GPO is driven in active state after a delay when the ST25TA02KB-D/P detects this field. Whatever the activity during the RF field detection (communication with the reader or not), GPO will stay active. It will be released when the ST25TA02KB-D/P leaves the RF field.

Figure 22. CMOS GPO configured as Field detect (GPO field = 0x70 or 0xF0)

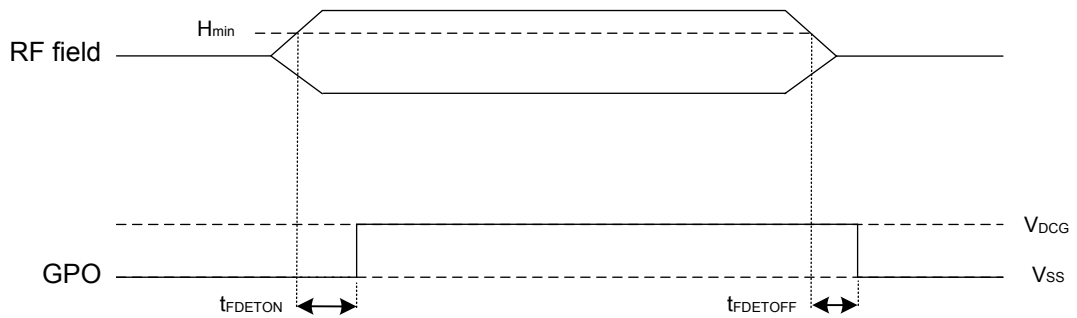
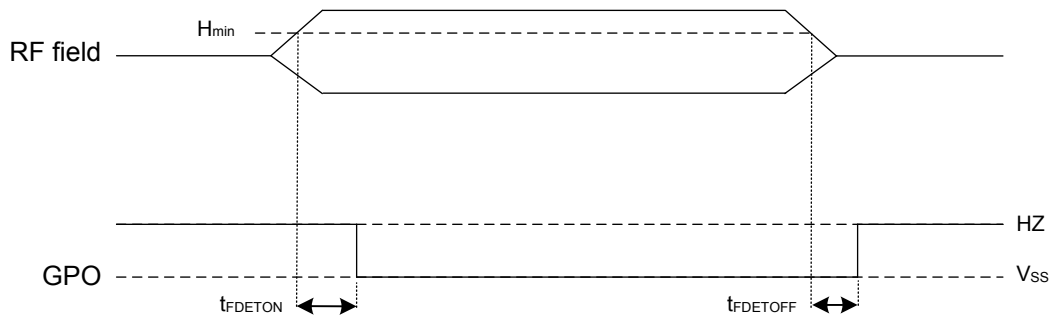

Figure 23. Open drain GPO configured as Field detect (GPO field = 0x70 or 0xF0)



4.3 TruST25™ digital signature feature

The ST25TxxxB devices support the TruST25™ digital signature feature, which allows the user to verify the authenticity of the device, based on a unique digital signature.

TruST25™ solution encompasses secure industrialization processes and tools deployed by STMicroelectronics to generate, store and check the signature in the device.

Implementation details are described in application note AN5101, contact your STMicroelectronics sales office to get this document.

5 Communication mechanism

This section describes the principle of communication between an RF host and the ST25TAxxxB devices.

5.1 Master and slave

The ST25TAxxxB act as slave devices on the RF channel and therefore wait for a command from the RF host before sending a response.

The RF host shall generate the RF field and the RF commands.

6 RF command sets

This section describes the ST25TAxxxB command sets that can be issued by the RF host.

There are three command families:

- the NFC Forum Type 4 Tag command set
- the ISO/IEC 7816-4 command set
- the ST-proprietary command set

The NFC Forum Type 4 Tag command set and the ISO/IEC 7816-4 command set use the I-Block format. For more details about the I-Block format, refer to [Section 6.2 I-Block format](#).

Two other command formats exist:

- the commands using the R-Block format
- the commands using the S-Block format

For more details about these formats, refer to [Section 6.3 R-Block format](#) and to [Section 6.4 S-Block format](#).

This section gives a brief description of the RF host commands. The format of these command sets is the I-Block format.

[Table 13](#) lists the RF command sets.

Table 13. RF command sets

Family command set	Command name	Class byte	Instruction code	Brief description
NFC Forum Type 4 Tag	NDEF Tag Application Select	0x00	0xA4	NDEF Tag Application Select
	CC select	0x00	0xA4	Selects the CC file
	NDEF Select	0x00	0xA4	Selects the NDEF file
	System select	0x00	0xA4	Selects the system file
	ReadBinary	0x00	0xB0	Reads data from file
	UpdateBinary	0x00	0xD6	Writes or erases data to an NDEF file
ISO/IEC 7816-4	Verify	0x00	0x20	Checks the right access of an NDEF file or sends a password
	ChangeReferenceData	0x00	0x24	Changes a Read or Write password
	EnableVerificationRequirement	0x00	0x28	Activates the password security
	DisableVerificationRequirement	0x00	0x26	Disables the password security
ST-proprietary	EnablePermanentState	0xA2	0x28	Enables the READ FORBIDDEN or the WRITE FORBIDDEN protection mode
	ExtendedReadBinary	0xA2	0xB0	Reads data from file
	UpdateFileType	0xA2	0xD6	Sets file type to NDEF or to proprietary
	StateControl	0xA2	0xD6	Drives the state of the GPO pin ⁽¹⁾
	SendInterrupt	0xA2	0xD6	Generates a pulse on the GPO pin ⁽¹⁾

1. Available on ST25TA02KB-D/P only

6.1 Structure of the command sets

The exchange of data between the RF host and the ST25TAxxxB uses three kinds of data formats, called blocks:

- I-Block (Information block): to exchange the command and the response
- R-Block (Receive ready block): to exchange positive or negative acknowledgment
- S-Block (Supervisory block): to use either the Deselect command or the Frame Waiting eXtension (WTX) command or response

This section describes the structure of I-Block, R-block and S-Block. This format is used for the application command set.

6.2 I-Block format

The I-Block is used to exchange data between the RF host and the ST25TAxxxB. It is composed of three fields, as detailed in [Table 14](#).

Table 14. I-Block format

Name	SoD		Payload	EoD
	PCB	DID	-	CRC
Length	1 byte	1 byte	1 to 251 bytes	2 bytes
PCB field				
DID field (optional)				
RF host to ST25TAxxxB: C-APDU				
ST25TAxxxB to RF host: R-APDU				
2 CRC bytes				

Table 15. PCB field of the I-Block format

	b7-b6	b5	b4	b3	b2	b1	b0
	0b00	0	0	X	0	1	X
I-Block							
RFU							
Must be set to 0							
DID field is present, if bit is set							
Must be set to 0							
Must be set to 1							
Block number ⁽¹⁾							

1. Follow ISO 14443_4 Block numbering rules (see note)

Note: Block numbering rules:

Reader rules:

- Rule A: The Reader block number shall be initialized to 0.
- Rule B: When an I-block or an R(ACK) block with a block number equal to the current block number is received, the Reader shall toggle the current block number before optionally sending a block to the ST25TAxxxB.

ST25TAxxxB rules:

- Rule C: The ST25TAxxxB block number shall be initialized to 1 at activation.
- Rule D: When an I-block is received, the ST25TAxxxB shall toggle its block number before sending a block.

Note: The ST25TAxxxB may check if the received block number is not in compliance with Reader rules to decide neither to toggle its internal block number nor to send a response block.

- Rule E: When an R(ACK) block with a block number not equal to the current ST25TAxxxB block number is received, the ST25TAxxxB shall toggle its block number before sending a block.

Note: There is no block number toggling when an R(NAK) block is received.

When the RF host sends a command to the ST25TAxxxB, the format of the payload is the C-APDU.

When the ST25TAxxxB sends a command to the RF host, the format of the payload is the R-APDU.

6.2.1 C-APDU: payload format of a command

The C-APDU format is used by the RF host to send a command to the ST25TAxxxB. [Table 16](#) describes its format.

Table 16. C-APDU format

Name	Payload field						
	CLA	INS	P1	P2	Lc	Data	Le
Length	1 byte	1 byte	1 byte	1 byte	1 byte	Lc byte	1 byte
Class byte							
- 0x00: standard command							
- 0xA2: ST command							
Instruction byte							
Param Byte 1							
Param Byte 2							
Number of bytes of the Data field							
Data bytes							
Number of bytes to be read in the ST25TAxxxB memory							

1. See [Table 13. RF command sets](#).

6.2.2 R-APDU: payload format of a response

The ST25TxxxB use the I-Block format to reply to a command that has used the I-Block format. This format is described in [Table 17](#).

Table 17. R-APDU format

Name	Payload field		
	Data (optional)	SW1	SW2
Length	Le byte	1 byte	1 byte
Data			
Status byte 1			
Status byte 2			

6.3 R-Block format

The R-Block is used to convey positive or negative acknowledgment between the RF host and the ST25TxxxB.

Table 18. R-Block format

NFC frame	SoD		-	EoD
	PCB	DID	Payload	CRC
Length	1 byte	1 byte	0 byte	2 bytes
R(ACK) without the DID field: 0xA2 or 0xA3				
R(ACK) with the DID field: 0xAA or 0xAB				
R(NAK) without the DID field: 0xB2 or 0xB3				
R(NAK) with the DID field: 0xBA or 0xBB				
DID field (optional)				
-				
2 CRC bytes				

There are two kinds of R-Blocks:

- R(ACK): the acknowledgment block sent by the RF host or by the ST25TxxxB
- R(NAK): the non-acknowledgment block sent by the RF host

Table 19. PCB field of the R-Block format

	b7-b6	b5	b4	b3	b2	b1	b0
	0b10	1	X	X	0	1	X
R-Block							
Must be set to 1.							
0: ACK							
1: NAK							
0: DID field is not present							
1: DID field is present							
Must be set to 0							
Must be set to 1							
Block number							

6.4 S-Block format

The S-Block is used to exchange control information between a reader and a contactless tag.

Table 20. S-Block format

NFC frame	SoD		-	EoD
	PCB	DID	Payload	CRC
Length	1 byte	1 byte	1 byte	2 bytes
S(DES) without the DID field : 0xC2				
S(DES) with the DID field : 0xCA				
S(WTX) without the DID field : 0xF2				
S(WTX) with the DID field : 0xFA				
DID field (optional)				
WTX field (optional) ⁽¹⁾				
2 CRC bytes				

1. This field is present when b5-b4 bits are set to 0b11 (S-Block is a WTX). See [Table 21. PCB field of the S-Block format](#).

There are two requests using the S-Block format:

- S(DES): the Deselect command
- S(WTX): the Waiting Frame eXtension command or response.

A Waiting Time eXtension request occurs in RF when the operating time needed by the ST25TxxxxB is greater than 19.2 ms.

The WTX field indicates the increase time factor to be used in this command execution ($FDT_{temp} = WTX * 19.2 \text{ ms}$). WTX depends on FWI.

Table 21. PCB field of the S-Block format

	b7-b6	b5-b4	b3	b2	b1	b0
	0b11	X	X	0	1	0
S-Block						
0b00: Deselect						
0b11: WTX						
0: DID field is not present						
1: DID field is present						
Must be set to 0						
Must be set to 1						
Must be set to 0						

Note:

After receiving the deselect command, the ST25TAxxxB enter the Standby power mode.

In response to a RATS command, the ST25TAxxxB return the FWI parameter (default frame waiting time used); when the ST25TAxxxB need more time for a command execution, they request a frame waiting time extension by responding 0xF2 0xWTX

(Request waiting time = FWI * WTX). If the reader accepts the ST25TAxxxB request, it acknowledges the request by sending the command 0xF2 0xWTX. The frame waiting time becomes FWI * WTX for the current command only.

6.5 CRC of the RF frame

The two CRC bytes check the data transmission between the RF host and the ST25TxxxB. For the RF frame, the CRC is computed on all the data bits in the frame, excluding parity bits, SOF and EOF, and the CRC itself.

The CRC is as defined in ISO/IEC 13239. The initial register content shall be 0x6363 and the register content shall not be inverted after calculation.

6.6 Status and error codes

This section lists the status and the error codes of the ST25TxxxB.

Table 22. Status code of the ST25TxxxB

	SW1	SW2	Comment
Value	0x90	0x00	Command completed successfully

Table 23. Error codes of the ST25TxxxB

	SW1	SW2	Comment
Length	1 byte	1 byte	
Value	0x63	0x00	Password is required
Value	0x63	0xCX	Password is incorrect, X further retries allowed (X can take values 0, 1 or 2)
Value	0x65	0x81	Unsuccessful updating
Value	0x67	0x00	Wrong frame length
Value	0x69	0x81	Command is incompatible with the file structure
Value	0x69	0x82	Security status not satisfied
Value	0x69	0x84	Reference data not usable
Value	0x69	0x85	Conditions of use not satisfied
Value	0x6A	0x80	Incorrect parameters Le or Lc
Value	0x6A	0x82	File or application not found
Value	0x6A	0x84	File overflow (Lc error)
Value	0x6A	0x86	Incorrect P1 or P2 values
Value	0x6D	0x00	INS field not supported
Value	0x6E	0x00	Class not supported

6.7 NFC Forum Type 4 Tag protocol

The ST25TxxxB command set is built to easily support the NFC Forum Type 4 Tag protocol.

6.7.1 NDEF Tag Application Select command

The RF host shall send this command to activate the NDEF Tag Application.

To activate the NDEF Tag Application, the RF host sends the Select command in addition to the sequence defined in the NFC Forum digital protocol.

Table 24 and Table 25 respectively define the C-APDU and R-APDU of the NDEF Tag Application Select command.

Table 24. C-APDU of the NDEF Tag Application Select command

Name	CLA	INS	P1	P2	Lc	Data	Le
-	0x00	0xA4	0x04	0x00	0x07	0xD2760000850101	0x00
Class byte							
Select instruction code							
P1 field							
P2 field							
Number of bytes of data							
Application ID							
Le field							

Table 25. R-APDU of the NDEF Tag Application Select command

	Data	SW1	SW2	Comment
Length	-	1 byte	1 byte	-
Value	-	0x90	0x00	Command completed
Value	-	0x6A	0x82	NDEF Tag Application not found
Value	-	0x6D	0x00	Class not supported
Value	-	0x6*	0x**	Refer to Section 6.6 Status and error codes

6.7.2 Capability Container Select command

The RF host uses the Capability Container Select procedure to select the capability container (CC) file.

The CC file is selected when this command returns "command completed" in the R-APDU. [Table 26](#) and [Table 27](#) respectively define the C-APDU and R-APDU of the Capability Container Select command.

Table 26. C-APDU of the Capability Container Select command

Name	CLA	INS	P1	P2	Lc	Data	Le
-	0x00	0xA4	0x00	0x0C	0x02	0xE103	-
Class byte							
Select instruction code							
P1 field							
P2 field							
Number of bytes of data							
CC file ID							
(empty field)							

Table 27. R-APDU of the Capability Container Select command

	Data	SW1	SW2	Comment
Length	-	1 byte	1 byte	-
Value	-	0x90	0x00	Command completed
Value	-	0x6A	0x82	File or application not found
Value	-	0x6D	0x00	Class not supported
Value	-	0x6*	0x**	Refer to Section 6.6 Status and error codes

6.7.3 NDEF Select command

The RF host uses the NDEF Select command to select the NDEF file.

The NDEF file is selected when this command returns "command completed" in the R-APDU. [Table 28](#) and [Table 29](#) respectively define the C-APDU and R-APDU of the NDEF Select command.

Table 28. C-APDU of the NDEF Select command

Name	CLA	INS	P1	P2	Lc	Data	Le
-	0x00	0xA4	0x00	0x0C	0x02	0x0001	-
Class byte							
Select instruction code							
P1 field							
P2 field							
Number of bytes of data							
0x0001: NDEF file							
(empty field)							

Table 29. R-APDU of the NDEF Select command

	Data	SW1	SW2	Comment
Length	-	1 byte	1 byte	-
Value	-	0x90	0x00	Command completed
Value	-	0x6A	0x82	File or application not found
Value	-	0x6*	0x**	Refer to Section 6.6 Status and error codes

6.7.4 System File Select command

The RF host uses this command to select the system file.

The System file is selected when this command returns "command completed" in the R-APDU.

[Table 30](#) and [Table 31](#) respectively define the C-APDU and R-APDU of the System File Select command.

Table 30. C-APDU of the System File Select command

Name	CLA	INS	P1	P2	Lc	Data	Le
-	0x00	0xA4	0x00	0x0C	0x02	0xE101	-
Class byte							
Select instruction code							
P1 field							
P2 field							
Number of bytes of data							
System file ID							
(empty field)							

Table 31. R-APDU of the System File Select command

	Data	SW1	SW2	Comment
Length	-	1 byte	1 byte	-
Value	-	0x90	0x00	Command completed
Value	-	0x6A	0x82	System file not found, no data is returned
Value	-	0x6*	0x**	Refer to Section 6.6 Status and error codes

6.7.5 ReadBinary command

On receiving the ReadBinary command, the ST25TxxxB read the requested memory field and send back its value in the R-APDU response.

Before sending a ReadBinary command, a file shall be selected by using a Select command.

The Response of the ReadBinary command is successful when the start offset P1P2 is lower than LEN: the length of the selected file (For more details about CC file, refer to [Section 3.1.2 CC file layout](#). For more details about NDEF file, refer to [Section 3.1.3 NDEF file layout](#). For more details about System file, refer to [Section 3.1.4 System file layout](#).)

[Table 32](#) and [Table 33](#) respectively define the C-APDU and R-APDU of the ReadBinary command.

Table 32. C-APDU of the ReadBinary command

Name	CLA	INS	P1 and P2	Lc	Data	Le
-	0x00	0xB0	2 bytes	-	-	1 byte
Class byte						
Read instruction code						
Offset in the file selected $0x0000 \leq P1P2 < LEN$						
(empty field)						
(empty field)						
Number of bytes to read: $0x00 \leq Le \leq MLe$						

Table 33. R-APDU of the ReadBinary command

	Data	SW1	SW2	Comment
Length	-	1 byte	1 byte	-
Value	Content read	0x90	0x00	Command completed
Value	-	0x69	0x85	Read access forbidden
Value	-	0x6A	0x80	Wrong Le value ($> MLe$)
Value	-	0x69	0x82	Security status not satisfied
Value	-	0x6A	0x82	File or application not found
Value	-	0x6A	0x86	Wrong start address ($P1P2 \geq LEN$)
Value	-	0x6*	0x**	Refer to Section 6.6 Status and error codes

6.7.6 UpdateBinary command

On receiving the UpdateBinary command, the ST25TAxxxB write the data field into the selected file and send back a status in the R-APDU response. If needed, The ST25TAxxxB devices will request a timing extension (see [Section 6.4 S-Block format](#)).

Before sending an UpdateBinary command, a file shall be selected by issuing a Select command.

[Table 34](#) and [Table 35](#) respectively define the C-APDU and R-APDU of the UpdateBinary command.

Table 34. C-APDU of the UpdateBinary command

Name	CLA	INS	P1 and P2	Lc	Data	Le
-	0x00	0xD6	2 bytes	1 byte	Lc bytes	-
Class byte						
Write instruction code						
Offset in the file selected						
Number of bytes of data ($0x01 \leq Lc \leq MLc$)						
Data to write in the ST25TAxxxB memory						
(empty field)						

Table 35. R-APDU of the UpdateBinary command

	Data	SW1	SW2	Comment
Length	-	1 byte	1 byte	-
Value	-	0x90	0x00	Command completed
Value	-	0x65	0x81	Unsuccessful updating
Value	-	0x69	0x85	Write access forbidden
Value	-	0x6A	0x80	Wrong Lc value (0 or > MLc)
Value	-	0x69	0x82	Security status not satisfied
Value	-	0x6A	0x82	File or application not found
Value	-	0x6A	0x86	Wrong start address
Value	-	0x6*	0x**	Refer to Section 6.6 Status and error codes

6.8 ISO/IEC 7816-4 commands

The ISO/IEC 7816-4 command set offers some extended features such as the protection of the NDEF file. This command set is used to manage the right access of the NDEF file.

6.8.1 Verify command

The Verify command has two functions:

1. Check if a password is required to access to the NDEF file (the LC field = 0x00).
2. Check that the password embedded in the Verify command grants access to the memory (Lc field = 0x10 and the password is present).

When the Lc field equals 0x00, the verify command returns a success code (0x90 00) provided that the access to the NDEF file does not require a password. When the access to the NDEF file is protected, the tag responds the error code 0x6300 to the Verify command. When the access to the NDEF file is forbidden, the tag responds the error code 0x6984 to the Verify command.

When the Lc field equals 0x10, on receiving the Verify command, the ST25TxxxB compare the requested password with the data contained in the request and reports whether the operation has been successful in the response.

Before sending this command, an NDEF file shall be selected by issuing the NDEF Select command. Thus, this command checks the right access condition of the last NDEF file selected.

After a successful password verification, an access is granted for the whole NDEF file.

[Table 36](#) and [Table 37](#) respectively define the C-APDU and R-APDU of the Verify command.

Table 36. C-APDU of the Verify command

Name	CLA	INS	P1 and P2	Lc	Data	Le
-	0x00	0x20	2 bytes	1 byte	Lc bytes	-
Class byte						
Instruction code						
Password identification						
0x0001: Read NDEF password transmit						
0x0002: Write NDEF password transmit						
Other: RFU						
0x00: the password is not present						
0x10: the password is present in the data field						
Password						
(empty field)						

Table 37. R-APDU of the Verify command

	Data	SW1	SW2	Comment
Length	-	1 byte	1 byte	-
Value	-	0x90	0x00	No password required (Lc = 0x0) or correct password (Lc = 0x10)
Value	-	0x69	0x84	The conditions of use are not satisfied (e.g.the access to the NDEF file is forbidden)
Value	-	0x69	0x81	Command incompatible with file structure
Value	-	0x69	0x82	Security status not satisfied
Value	-	0x6A	0x80	Incorrect parameter in command data field
Value	-	0x63	0x00	A password is required
Value	-	0x63	0xCX	The password transmitted is incorrect and X encodes the number of further allowed retries
Value	-	0x6*	0x**	Refer to Section 3.4 NDEF file passwords

6.8.2 Change Reference Data command

The Change Reference Data command replaces the read or write password related to the NDEF files previously selected. It can be performed only if the security status satisfies the security attributes for this command.

Before sending this command, the verify command with the correct NDEF write password shall be issued. Thus, this command changes the reference data of the NDEF file.

[Table 38](#) and [Table 39](#) respectively define the C-APDU and R-APDU of the Change Reference Data command.

Table 38. C-APDU of the Change Reference Data command

Name	CLA	INS	P1 and P2	Lc	Data	Le
-	0x00	0x24	2 bytes	0x10	Lc bytes	-
Class byte						
Instruction code						
Password identification						
0x0001: Read password transmit						
0x0002: Write password transmit						
Other: RFU						
0x10: the password is present in the data field						
NDEF new file Password						
(empty field)						

Table 39. R-APDU of the Change Reference Data command

	Data	SW1	SW2	Comment
Length	0	1 byte	1 byte	-
Value	-	0x90	0x00	Command completed, the password value has been changed
Value	-	0x69	0x81	Command is incompatible with the file structure
Value	-	0x65	0x81	Unsuccessful updating
Value	-	0x69	0x82	Security status not satisfied
Value	-	0x6A	0x80	Incorrect parameter in file structure
Value	-	0x6A	0x82	File or application not found
Value	-	0x6A	0x86	Incorrect P1 or P2 values
Value	-	0x6*	0x**	Refer to Section 6.6 Status and error codes

6.8.3 Enable Verification Requirement command

The Enable Verification Requirement command activates the protection by password of the NDEF file. When this command is successful, the read or write access to the NDEF file is protected by a 128-bit password. It can be performed only if the security status satisfies the security attributes for this command.

The response time of the command is ~5 ms.

Before sending this command, the verify command with the correct NDEF write password shall be issued. Thus, this command changes the protection mode of the NDEF file.

[Table 40](#) and [Table 41](#) respectively define the C-APDU and R-APDU of the Enable Verification Requirement command.

Table 40. C-APDU of the Enable Verification Requirement command

Name	CLA	INS	P1 and P2	Lc	Data	Le
-	0x00	0x28	2 bytes	-	-	-
Class byte						
Instruction code						
New security attributes						
0x0001: Enable the READ PROTECTED state						
0x0002: Enable the WRITE PROTECTED state						
Other: RFU						
(empty field)						
(empty field)						
(empty field)						

Table 41. R-APDU of the Enable Verification Requirement command

	Data	SW1	SW2	Comment
Length	0	1 byte	1 byte	-
Value	-	0x90	0x00	Protection mode changed to PROTECTED state
Value	-	0x69	0x81	Command is incompatible with the file structure
Value	-	0x69	0x82	Security status not satisfied
Value	-	0x6A	0x80	Incorrect parameter in command data field
Value	-	0x6A	0x82	File or application not found
Value	-	0x6*	0x**	Refer to Section 6.6 Status and error codes

6.8.4 Disable Verification Requirement command

The Disable Requirement command deactivates the protection by password of the NDEF file. When this command is successful, the read or write access to the NDEF file is granted without security requirements. It can be performed only if the security status satisfies the security attributes for this command.

Before sending this command, the verify command with the correct NDEF write password shall be issued. Thus, this command changes the protection mode of the NDEF file.

This response time of the command is ~6 ms.

[Table 42](#) and [Table 43](#) respectively define the C-APDU and R-APDU of the Disable Verification Requirement command.

Table 42. C-APDU of the Disable Verification Requirement command

Name	CLA	INS	P1 and P2	Lc	Data	Le
-	0x00	0x26	2 bytes	-	-	-
Class byte						
Instruction code						
New security attributes						
0x0001: Enable the READ UNPROTECTED state						
0x0002: Enable the WRITE UNPROTECTED state						
Other: RFU						
(empty filed)						
(empty filed)						
(empty filed)						

Table 43. R-APDU of the Disable Verification Requirement command

	Data	SW1	SW2	Comment
Length	0	1 byte	1 byte	-
Value	-	0x90	0x00	Protection mode set to UNPROTECTED state
Value	-	0x69	0x81	Command is incompatible with the file structure
Value	-	0x69	0x82	Security status not satisfied
Value	-	0x6A	0x80	CC file or System file selected
Value	-	0x6A	0x82	File or application not found
Value	-	0x6A	0x86	Incorrect P1 or P2 values
Value	-	0x65	0x81	Update failed
Value	-	0x6*	0x**	Refer to Section 6.6 Status and error codes

6.9 ST-proprietary command set

The RF host can be issued with the command set described in this section.

6.9.1 ExtendedReadBinary command

On receiving the ExtendedReadBinary command, the ST25TAXxxB read the requested memory field and send back its value in the R-APDU response.

The format and behavior of this command are identical to those of the ReadBinary command (see [Section 6.7.5 ReadBinary command](#)), the only difference being the value of the CLA field in the C-APDU as shown in [Table 44](#). Refer to [Table 33. R-APDU of the ReadBinary command](#) for the list of return codes and definitions.

Table 44. C-APDU of the ExtendedReadBinary command

Name	CLA	INS	P1 and P2	Lc	Data	Le
-	0xA2	0xB0	2 bytes	-	-	1 byte
ST Class byte						
Read instruction code						
Offset in the file selected						
(empty field)						
(empty field)						
Number of bytes to read between $0x00 \leq Le \leq MLe$						

6.9.2 EnablePermanentState command

This command configures the protection of the NDEF file to the READ FORBIDDEN or to the WRITE FORBIDDEN state.

This response time of the is ~6 ms.

[Table 45](#) and [Table 46](#) respectively define the C-APDU and R-APDU of the EnablePermanentState command.

Table 45. C-APDU of the EnablePermanentState command

Name	CLA	INS	P1 and P2	Lc	Data	Le
-	0xA2	0x28	2 bytes	-	-	-
Class byte						
Instruction code						
New security attributes						
0x0001: Enable the READ FORBIDDEN state						
0x0002: Enable the WRITE FORBIDDEN state						
Other: RFU						
(empty field)						
(empty field)						
(empty field)						

Table 46. R-APDU of the EnablePermanentState command

	Data	SW1	SW2	Comment
Length	-	1 byte	1 byte	-
Value	-	0x90	0x00	Command completed
Value	-	0x65	0x81	Update failed
Value	-	0x69	0x82	Security status not satisfied
Value	-	0x6A	0x82	File or application not found
Value	-	0x6A	0x86	Incorrect P1 or P2 values
Value	-	0x6*	0x**	Refer to Section 6.6 Status and error codes

6.9.3 UpdateFileType command

This command makes it possible to modify the value of the T field from the CC file (see [Table 3. File identifier](#)).

This command is successful only when application and file 0x0001 are selected and if the file length has previously been set to 0x0000 (message invalid) and protection modes have been set to READ UNPROTECTED and WRITE UNPROTECTED states.

The response time of the command is ~6 ms.

[Table 47](#) and [Table 48](#) respectively define the C-APDU and R-APDU of the UpdateFileType command.

Table 47. C-APDU of the UpdateFileType command

Name	CLA	INS	P1	P2	Lc	Data	Le
Value	0xA2	0xD6	0x00	0x00	0x01	1 byte	-
Class byte							
Select instruction code							
P1 field							
P2 field							
Number of bytes of data							
File type							
-							

Table 48. R-APDU of the UpdateFileType command

	Data	SW1	SW2	Comment
Length	-	1 byte	1 byte	-
Value	-	0x90	0x00	Command completed
Value	-	0x69	0x82	Security status not satisfied
Value	-	0x6A	0x80	CC file or System file selected
Value	-	0x6A	0x82	File or application not found
Value	-	0x6A	0x86	Incorrect P1 or P2 values
Value	-	0x6*	0x**	Refer to Section 6.6 Status and error codes

6.9.4 SendInterrupt command

On receiving the SendInterrupt command, the ST25TA02KB-D or ST25TA02KB-P device generates a pulse on the GPO pin. It starts at the end of the command and ends at the end of the RF response.

Before sending this command, the system file shall be selected by issuing the System Select command.

[Table 49](#) and [Table 50](#) respectively define the C-APDU and R-APDU of the SendInterrupt command.

Table 49. C-APDU of the SendInterrupt command

	CLA	INS	P1 and P2	Lc	Data	Le
Length	1 byte	1 byte	2 bytes	1 byte	-	-
Value	0xA2	0xD6	0x001E	0x00	-	-

Table 50. R-APDU of the SendInterrupt command

	Data	SW1	SW2	Comment
Length	-	1 byte	1 byte	-
Value	-	0x90	0x00	The interrupt has been sent
Value	-	0x6A	0x80	The GPO is not configured as an interrupt mode
Value	-	0x6A	0x82	File or application not found
Value	-	0x6A	0x86	Incorrect P1 or P2 values
Value	-	0x6E	0x00	Class not supported

6.9.5 StateControl command

On receiving the StateControl command with activation value 0x00, the ST25TA02KB-D or ST25TA02KB-P device drives the GPO pin to active state. On receiving the StateControl command with deactivation value 0x01, the ST25TA02KB-D or ST25TA02KB-P device releases the GPO pin that returns to inactive state.

Before sending this command, the system file shall be selected by issuing the System Select command.

[Table 51](#) and [Table 52](#) respectively define the C-APDU and R-APDU of the StateControl command.

Table 51. C-APDU of the StateControl command

	CLA	INS	P1 and P2	Lc	Data	Le
Length	1 byte	1 byte	2 bytes	1 byte	-	-
Activation value	0xA2	0xD6	0x001F	0x01	0x00	-
Deactivation value	0xA2	0xD6	0x001F	0x01	0x01	-

Table 52. R-APDU of the StateControl command

	Data	SW1	SW2	Comment
Length	-	1 byte	1 byte	-
Value	-	0x90	0x00	The set or reset has been sent
Value	-	0x6A	0x80	The GPO is not configured in StateControl mode
Value	-	0x6A	0x82	File or application not found
Value	-	0x6A	0x86	Incorrect P1 or P2 values
Value	-	0x6E	0x00	Class not supported

6.10 ISO14443-4 / NFC-A command set

This section describes the commands used to activate and deactivate the tag.

6.10.1 Anticollision command set

Table 53 lists the commands that can be issued only by the RF host. The format of these commands is described in the NFC Forum Digital Protocol specification.

Table 53. Commands issued by the RF host

Family command set	Command name	Instruction code
NFC-A technology	ALL_REQ	0x52 ⁽¹⁾
	SENS_REQ	0x26 ⁽¹⁾
	SDD_REQ	0x93 or 0x95
	SEL_REQ	0x93 or 0x95
	SLP_REQ	0x50

1. Code on 7 bits.

Note: In response to a SDD_REQ Command with a SEL_PAR value equal to 20h, ST25TAxxxB in the Operating Field transmit the requested cascade level of their NFCID1 (NFCID1 CL_n, with n = 1 or 2). The NFCID1 of ST25TAxxxB consists of 7 bytes. The length of the Response containing a complete NFCID1 cascade level (i.e., NFCID1 CL1, or NFCID1 CL2) is always 5 bytes. The coding of the Response depends on the value of the SEL_CMD byte and the size of the NFCID1. Refer to the example below for more details.

Table 54. Example of anticollision sequence

Command	Code	Comment	Response	Code	Comment
SENS_REQ or ALL-REQ	26 52	-	ATQA	42 00	UID double size bit frame anticollision
SDD_REQ 1	93 20	NVB 20 Number Valid bit (2 bytes Code and NVB)	-	CT uid1 uid2 uid3 BCC	CT Cascade Tag "0x88" (UID 7bytes) BCC Block Check Character (XOR previous Bytes)
SEL_REQ 1	93 70 CT uid1 uid2 uid3 BBC	NVB 70 (cmd NVB Uid lower bytes) CT Cascade Tag "0x88"	SAK and CRC	04 DA17	UID not complete
SDD_REQ 2	95 20	NVB 20 Number Valid bit (2 bytes Code and NVB)	-	uid4 uid5 uid6 uid7 BCC	(UID 7bytes) BCC Block Check Character (XOR previous Bytes)
SEL_REQ 1	95 70 uid4 uid5 uid6 uid7 BBC	NVB 70 (cmd NVB Uid Upper bytes)	SAK and CRC	20 FC70	UID complete

6.10.2 RATS command and ATS response

RATS command and ATS response are used for NFC Forum Type 4A Tag Platform Device Activation (as defined in NFC Forum Digital Protocol specification).

Table 55 details the RATS command. This command shall be sent after the anticollision process, and expects an ATS response (detailed in Table 57) from the ST25TAxxxB device.

Table 55. RATS command

Name	INS	Param		CRC
Byte field	0xE0	1 byte		2 bytes
Bit field	-	b7-b4	b3-b0	-
Instruction code				
FSDI				
DID (0 ≤ DID ≤ 14)				
2 CRC bytes				

The FSDI field codes the FSD that defines the maximum size that an RF host is able to receive. Table 56 gives the conversion from FSDI to FSD.

Table 56. Conversion from FSDI to FSD

FSDI	0x0	0x1	0x2	0x3	0x4	0x5	0x6	0x7	0x8	0x9-0xE	0xF
FSD	16	24	32	40	48	64	96	128	256	RFU	256

The DID (Dynamic ID, optionally affected to the ST25TAxxxB by the host to address ST25TAxxxB in all commands) field defines the value of the addressed ST25TAxxxB.

If DID is not '0', the ST25TAxxxB ignore the command if it contains a DID different from the one affected to ST25TAxxxB during RATS.

Table 57. ATS response

Name	TL	T0	TA(1)	TB(1)		TC(1)	CRC
Byte field	0x05	0x75	0x80	0x60		0x02	2 bytes
Bit field	-	-	-	b7-b4	b3-b0	-	-
Length of the ATS response							
FSCI = 5 → FSC = 64 bytes							
The maximum ascending data rate is 106 kbps							
The maximum descending data rate is 106 kbps							
FWI field (FWI = 6 → FWT = 19.2 ms)							
SFGI field (SFGI = 0 → SFGT = 302 μs)							
The DID is supported							
2 CRC bytes							

The FSCI codes the FSC which stands for the maximum frame size that the ST25TxxxxB are able to receive. The ST25TxxxxB are able to receive up to 64 bytes of command. If the RF host sends a command with more than 64 bytes, the ST25TxxxxB will be unable to treat the command and will not reply.

The FWI which stands for the Frame Waiting time Integer codes the FWT. This time corresponds to the maximum duration while an RF host shall send before sending the next command.

The SFGI which stands for the Start-up Frame Guard Time is the minimum time that the reader shall wait after receiving the response of the ST25TxxxxB.

6.10.3 PPS command and response

PPS (Protocol and Parameter Selection) command and response are defined in ISO/IEC 14443-4, in the Protocol Activation of PICC Type A.

The PPS command allows the user to change the ascending (RF host to ST25TxxxxB) and descending (ST25TxxxxB to RF host) data rates. Usage of this command is optional, as the ST25TxxxxB devices only support 106 Kb/s in both directions.

Table 58. PPS command

Name	INS (PPSS)		PPS0	PPS1			CRC
Byte field	0xDX		0x11	1 byte			2 bytes
Bit field	b7-b4	b3-b0	-	b7-b4	b3-b2	b1-b0	-
Description	Instruction code	DID	PPS1 is present	RFU	Descending data rate (106 kbit/s) = 0b00	Ascending data rate (106 kbit/s) = 0b00	CRC

The ascending and descending data rates shall be coded as described in [Table 59](#).

Table 59. Ascending and descending data rate coding

Value	0b00	0b01	0b10	0b11
Data rate	106 kbps	RFU	RFU	RFU

When the ST25TxxxxB receive a PPS request as described in [Table 58](#), they return the following response. The data rate of this response is 106 kbps. [Table 60](#) gives the details of the PPS response.

Table 60. PPS response

Name	Response (PPSS)		CRC
Byte field	0xDX		2 bytes
Bit field	b7-b4	b3-b0	-
Description	Response code	DID field	CRC

6.10.4 DESELECT command

DESELECT command and response are defined in ISO/IEC 14443-4, in the Protocol Deactivation of PICC Type A.

This command makes it possible to put the tag in Standby power mode (This state can also be reached by a shutdown of the RF field.)

It consists of an S(DES) request block (see [Section 6.4 S-Block format](#)) sent by the RF host and an S(DES) response sent as acknowledge by the tag.

7 Functional procedures

In addition to the NDEF Detection, NDEF Read and NDEF Write procedures described in the NFC Forum Type 4 Tag specification, the ST25TxxxB devices support the procedures described in this section to manage the protection of the NDEF file.

7.1 Protecting an NDEF file

The RF host executes this procedure to enable the read or write protection of an NDEF file. This process can be reverted by the procedure described in [Section 7.3 Unprotecting an NDEF file](#).

1. Select the NDEF Tag Application
2. Select the NDEF file
3. Transmit the NDEF file Write password by using the Verify command
4. Activate the protection by sending the EnableVerificationRequirement command with the adequate security attribute (see [Section 6.8.3 Enable Verification Requirement command](#))

7.2 Accessing a protected NDEF file

The RF host executes this procedure to access an NDEF file that has been previously protected by a password.

1. Select the NDEF Tag Application
2. Select the NDEF file
3. Transmit the Read or Write password (according to the protected access) using the Verify command
4. Access the NDEF file using the ReadBinary or the UpdateBinary command

7.3 Unprotecting an NDEF file

The RF host executes this procedure to disable the read or write access protection of an NDEF file. This process can be reverted by the procedure described in [Section 7.1 Protecting an NDEF file](#).

1. Select the NDEF Tag Application
2. Select the NDEF file
3. Transmit the NDEF file Write password by using the Verify command
4. Deactivate the protection by sending the DisableVerificationRequirement command with the adequate security attribute (see [Section 6.8.4 Disable Verification Requirement command](#)).

7.4 Locking an NDEF file

The RF host executes this procedure to permanently permanently forbid the read or write access to an NDEF file. Compared to the one described in [Section 7.1 Protecting an NDEF file](#), this process cannot be reverted.

1. Select the NDEF Tag Application
2. Select the NDEF file
3. Transmit the NDEF file Write password by using the Verify command
4. Send an EnablePermanentState command with the adequate security attribute (see [Section 6.9.2 EnablePermanentState command](#))

7.5 Reaching the READ-ONLY state

The RF host executes this procedure to set the tag in the READ-ONLY state defined in the NFC T4T specification

1. Write a non-empty NDEF message using the NDEF Write procedure from the NFC T4T specification
2. Lock the write access using the procedure described in [Section 7.4 Locking an NDEF file](#)

7.6 Changing a password

The RF host executes this procedure to modify the read or write password used for the protection of the NDEF file

1. Select the NDEF Tag Application
2. Select the NDEF file

3. Transmit the old password value using the Verify command with the adequate security attribute (see [Section 6.8.1 Verify command](#))
4. Transmit the new password value using the ChangeReferenceData command with the same security attribute (see [Section 6.8.2 Change Reference Data command](#))

7.7 Changing the file type

The RF host executes this procedure to change the value of the T field from the CC file

1. Select the NDEF Tag Application
2. Select the file 0x0001 using the NDEF Select command
3. Unprotect all file accesses using the procedure detailed in [Section 7.3 Unprotecting an NDEF file](#)
4. Set the File Length to 0x0000 using the UpdateBinary command
5. Send an UpdateFileType command with the new T field value as data (see [Section 6.9.3 UpdateFileType command](#))

Caution: If the T field is set to a value different from 0x04, the file 0x0001 is no longer an NDEF file but a proprietary file, and the tag is in a state out of the scope of the NFC Forum.

8 UID: unique identifier

Each ST25TAxxxB device is uniquely identified by a 7-byte unique identifier (UID). The UID is a read-only code and comprises:

- the IC manufacturer code, on 1 byte (0x02 for STMicroelectronics)
- the Product code, on 1 byte
- a device number, on 5 bytes.

Table 61 describes the UID format.

Table 61. UID format

-	0x02	1 byte ⁽¹⁾	5 bytes
IC manufacturer code			
Product code			
Device number			

1. This byte is 0xE3 for ST25TA02KB, 0xA3 for ST25TA02KB-P, 0xF3 for ST25TA02KB-D and 0xE4 for ST25TA512B.

9 Maximum ratings

Stressing the devices above the ratings listed in Table 62 may cause permanent damage to them. These are stress ratings only and operation of the devices at these or any other conditions above those indicated in the operating sections of this specification is not implied. Exposure to absolute maximum rating conditions for extended periods may affect device reliability.

Table 62. Absolute maximum ratings

Symbol	Parameter		Min.	Max.	Unit
T _A	Ambient operating temperature		-40	85	°C
T _{STG}	Storage conditions	Sawn wafer on UV tape	15	25	°C
h _{STG}			-	9 ⁽¹⁾	months
t _{STG}			Kept in its original packing form		
T _{STG}	Storage temperature	Sawn bumped wafer	15	25	°C
	Storage time	(kept in its antistatic bag)	-	9 ⁽²⁾	months
I _{CC} ⁽³⁾	RF supply current AC0 - AC1		-	100	mA
V _{MAX_1} ⁽³⁾	RF input voltage amplitude between AC0 and AC1, V _{SS} pad left floating	V _{AC0} - V _{AC1} (peak to peak)	-	10	V
V _{ESD}	Electrostatic discharge voltage (human body model) ⁽⁴⁾	AC0 - AC1	-	2000	V

1. Counted from ST shipment date.

2. Counted from ST production (taping) date.

3. Based on characterization, not tested in production. Maximum absorbed power = 100 mW at 7.5 A/m.

4. AEC-Q100-002 (compliant with JEDEC Std JESD22-A114A, C1 = 100 pF, R1 = 1500 W, R2 = 500 W).

10 GPO characteristics

This section summarizes the operating and measurement conditions of the GPO feature. The DC and AC characteristics are derived from tests performed under the measurement conditions summarized in the following tables. The GPO I/O is CMOS compliant.

10.1 CMOS GPO characteristics (ST25TA02KB-P only)

Table 63. CMOS GPO operating conditions

Symbol	Parameter	Min.	Max.	Unit
V _{DCCG}	GPO power supply	1.65	5.5	V

Table 64. CMOS GPO DC characteristics

Symbol	Parameter	Test condition	Min.	Typ.	Max.	Unit
V _{OL}	Output Low voltage (GPO)	I _{OL} = 0.7 mA, V _{DCCG} = 1.65 V	-	-	0.2 V _{DCCG}	V
V _{OH}	Output High voltage (GPO)	I _{OH} = -0.7 mA, V _{DCCG} = 1.65 V	0.8 V _{DCCG}	-	-	
V _{OL}	Output Low voltage (GPO)	I _{OL} = 2 mA, V _{DCCG} = 2.7 V	-	-	0.2 V _{DCCG}	
V _{OH}	Output High voltage (GPO)	I _{OH} = -2 mA, V _{DCCG} = 2.7 V	0.8 V _{DCCG}	-	-	
V _{OL}	Output Low voltage (GPO)	I _{OL} = 4 mA, V _{DCCG} = 5.5 V	-	-	0.2 V _{DCCG}	
V _{OH}	Output High voltage (GPO)	I _{OH} = -4 mA, V _{DCCG} = 5.5 V	0.8 V _{DCCG}	-	-	
I _{L_VDCCG}	Input leakage (V _{DCCG})	V _{DCCG} = 1.8 V, T = 90 °C	-	5	75	nA
		V _{DCCG} = 2.7 V, T = 90 °C	-	6	100	
		V _{DCCG} = 5.5 V, T = 90 °C	-	14	150	

Table 65. CMOS GPO AC Characteristics

Symbol	Parameter	Test condition	Min.	Max.	Unit
t _f (IO) out	Output fall time ⁽¹⁾	CL = 50 pF, V _{DCCG} = 1.65 V to 5.5 V	-	90 ^{(2) (3)}	ns
t _r (IO) out	Output rise time ⁽¹⁾	CL = 50 pF, V _{DCCG} = 1.65 V to 5.5 V	-	90 ⁽³⁾	ns

1. V_{ref(t)} output timing reference levels 0.3 V_{DCCG} to 0.7 V_{DCCG} V.
2. When GPO is set in RF Field detection mode, return to quiet position could request a longer time, depending upon ST25TAxxxB activity (~20 ms).
3. Characterization only on bench.

Note: The GPO (general purpose output) can sink or source at least 0.7 mA at 1.65 V, 2 mA at 2.7 V, and 4 mA at 5.5 V.

10.2 Open drain GPO characteristics (ST25TA02KB-D only)

Table 66. Open drain GPO operating conditions

Symbol	Parameter	Min.	Max.	Unit
$V_{PULL-UP}$	Pull-up supply	1.65	5.5	V

Table 67. Open drain GPO DC characteristics

Symbol	Parameter	Test condition	Min.	Max.	Unit
$V_{OL}^{(1)}$	Output Low voltage (GPO)	$I_{OL} = 1 \text{ mA}$, Pull-up supply = 1.65 to 5.5 V	-	0.4 V	V

1. Characterized only.

11 GPO parameters

This section lists typical (characterized only) timings of the GPO according to its configuration.

Table 68. GPO timings measurement

GPO field	I/F	Condition	Command	Symbol	Typ.	Unit
Session Open	0x10	GPO in active state when session active	NDEF select	CmdEOFtoGPActive ⁽¹⁾	170	µs
	or 0x90	GPO returns in inactive state	Deselect	CmdEOFtoGPInactive ⁽²⁾	370	
WIP	0x20	GPO in active state when programming	Update Binary	CmdEOFtoGPActive	75	µs
	or 0xA0			Writing time duration (No time extension) ⁽³⁾	ms	
Message In Progress	0x30	GPO in active state when modifying NDEF	UpdateBinary (Msg Length #0)	CmdEOFtoGPActive ⁽¹⁾	75	µs
	or 0xB0		UpdateBinary	Writing time duration (No time extension) ⁽³⁾	ms	
Interrupt	0x40	GPO in active state after receiving an Interrupt command	SendInterrupt	CmdEOFtoGPActive ⁽¹⁾	75	µs
	or 0xC0			Pulse duration	540	
State Control	0x50	GPO in active state when activated	StateControl(0)	CmdEOFtoGPActive ⁽¹⁾	60	µs
	or 0xD0	GPO returns in inactive state when deactivated	StateControl(1)	CmdEOFtoGPInactive ⁽²⁾	60	
RF Busy	0x60	GPO in active state after receiving an RF command	Anticollision command or start of RF disturb ⁽⁴⁾	CmdSOFtoGPActive ⁽⁵⁾	6	µs
	or 0xE0	GPO returns in inactive state after deselection or RF command in another protocol	Deselect or end of RF disturb ⁽⁴⁾	CmdEOFtoGPInactive ⁽²⁾	460	
Field detect	0x70	GPO in active state when RF field is present	-	t _{FDETON}	140	µs
	or 0xF0			t _{FDETOFF}	20	

1. CmdEOFtoGPActive equals CmdEOFtoGPHigh for ST25TA02KB-P, and CmdEOFtoGPLow for ST25TA02KB-D.
2. CmdEOFtoGPInactive equals CmdEOFtoGPLow for ST25TA02KB-P, and CmdEOFtoGPHz for ST25TA02KB-D.
3. Writing time is a function of the message length and is automatically managed by the ST25TA02KB-D and by the ST25TA02KB-P. The NDEF message is mapped on memory blocks of 16 bytes. Each basic block has a typical update time duration of 6 ms, including the internal verify.
4. Command using another RF protocol.
5. CmdSOFtoGPActive equals CmdSOFtoGPHigh for ST25TA02KB-P, and CmdSOFtoGPLow for ST25TA02KB-D.

12 RF electrical parameters

This section summarizes the operating and measurement conditions, and the DC and AC characteristics of the devices in RF mode.

The parameters in the DC and AC characteristics tables that follow are derived from tests performed under the measurement conditions summarized in the relevant tables. Designers should check that the operating conditions in their circuit match the measurement conditions when relying on the quoted parameters.

Table 69. Default operating conditions

Symbol	Parameter	Min.	Max.	Unit
T _A	Ambient operating temperature	-40	85	°C

Table 70. RF characteristics

Symbol	Parameter	Condition	Min	Typ	Max	Unit
f _C	External RF signal frequency	-	13.553	13.56	13.567	MHz
H_ISO	Operating field according to ISO	T _A = 0°C to 50°C	1500	-	7500	mA/m
H_Extended	Operating field in extended temperature range	T _A = -40°C to 85°C	100	-	7500	mA/m
H _{min}	Field detect, set-up field	T _A = -40°C to 85°C	-	50	-	mA/m
MI _{CARRIER}	100% carrier modulation index	MI = (A - B) / (A + B)	90	-	100	%
t ₁	Pause A length	-	28 / f _C	-	40.5 / f _C	µs
t ₂	Pause A low time	-	7 / f _C	-	t ₁	µs
t ₃	Pause A rise time	-	1.5 t ₄	-	16 / f _C	µs
t ₄	Pause A rise time section	-	0	-	6 / f _C	µs
t _{MIN CD}	Minimum time from carrier generation to first data	From H _{min}	-	-	5	ms
W _t	RF write time (including internal Verify) for one page	-	-	4.468 ⁽¹⁾	-	ms
C _{TUN} ⁽²⁾	Internal tuning capacitor ⁽³⁾	f _C = 13.56 MHz	45	50	55	pF
t _{RF_OFF}	RF OFF time	Chip reset	-	-	0.1	ms

1. Time between command EOF and Response SOF when updating NDEF Message Length.

2. See Capacitor value in [Table 72. Ordering information scheme](#)

3. Characterized only, at room temperature only, measured at V_{AC0}-V_{AC1} = 5 V peak to peak at 13.56 MHz.

Note:

All timing characterizations performed on a reference antenna with the following characteristics:

- External size: 75 mm x 48 mm
- Number of turns: 4
- Width of conductor: 0.5 mm
- Space between two conductors: 0.5 mm
- Value of the tuning capacitor: 50 pF (ST25TAxxxB)
- Value of the coil: 2.5 µH
- Tuning frequency: 14.2 MHz.

13 Package information

In order to meet environmental requirements, ST offers these devices in different grades of ECOPACK[®] packages, depending on their level of environmental compliance. ECOPACK[®] specifications, grade definitions and product status are available at: www.st.com.

ECOPACK[®] is an ST trademark.

13.1 UFDFPN5 package information

Figure 24. UFDFPN5 - 5-lead, 1.7 × 1.4 mm, 0.55 mm thickness package outline

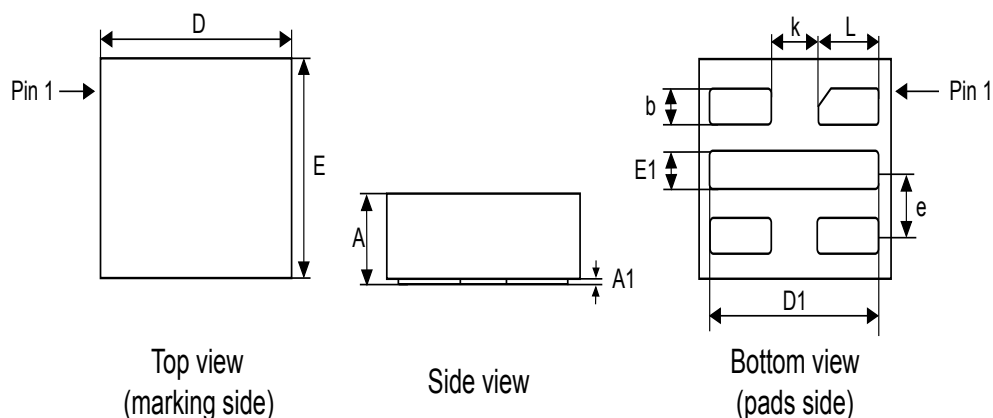

1. Max. package warpage is 0.05 mm.
2. Exposed copper is not systematic and can appear partially or totally according to the cross section.
3. Drawing is not to scale.

Table 71. UFDFPN5 - 5-lead, 1.7 × 1.4 mm, 0.55 mm thickness package mechanical data

Symbol	millimeters			inches ⁽¹⁾		
	Min	Typ	Max	Min	Typ	Max
A	0.500	0.550	0.600	0.0197	0.0217	0.0236
A1	0.000	-	0.050	0.0000	-	0.0020
b ⁽²⁾	0.175	0.200	0.225	0.0069	0.0079	0.0089
D	1.600	1.700	1.800	0.0630	0.0669	0.0709
D1	1.400	1.500	1.600	0.0551	0.0591	0.0630
E	1.300	1.400	1.500	0.0512	0.0551	0.0591
E1	0.175	0.200	0.225	0.0069	0.0079	0.0089
e	-	0.400	-	-	0.0157	-
L	0.500	0.550	0.600	0.0197	0.0217	0.0236
L1	-	0.100	-	-	0.0039	-
k	-	0.400	-	-	0.0157	-

1. Values in inches are converted from mm and rounded to 4 decimal digits.

2. Dimension b applies to plated terminal and is measured between 0.15 and 0.30mm from the terminal tip.

14 Ordering information

Table 72. Ordering information scheme

Example:	ST25	T	A	02K/512	B	-A/P/D	C	6	F/G/H	5
Device type	ST25 = RF memory									
Product type	T = Tags + RFID									
Protocol	A = ISO14443-A									
Memory density	02K = 2 Kbits		512 = 512 bits							
Product version	B = Version B									
Interface	A = None		P = P-CMOS GPO		D = Open drain GPO					
Features	C = Counter									
Operating temperature	6 = - 40 °C to 85 °C									
Package	F = Sawn and bumped wafer, 75 ± 10 µm		G = Sawn and bumped wafer, 120 ± 10 µm		H = UFDFPN5 package (ST25TA02KB-D and ST25TA02KB-D only)					
Capacitance	5 = 50 pF									

Note: Parts marked as “ES”, “E” or accompanied by an Engineering Sample notification letter, are not yet qualified and therefore not yet ready to be used in production and any consequences deriving from such usage will not be at ST charge. In no event, ST will be liable for any customer usage of these engineering samples in production. ST Quality has to be contacted prior to any decision to use these Engineering samples to run qualification activity.

Revision history

Table 73. Document revision history

Date	Revision	Changes
13-Nov-2017	1	Initial release.
27-Sep-2018	2	Added: <ul style="list-style-type: none">Section 4.2.1 Inactive configuration (GPO field = 0x00 or 0x80) Updated: <ul style="list-style-type: none">Section 4.2 General purpose output (GPO), only available on ST25TA02KB-D/PSection 4.2.2 Session Open configuration (GPO field = 0x10 or 0x90)

Contents

1	Functional description	2
1.1	Functional mode	4
1.1.1	Tag mode	5
2	Signal description	6
2.1	Antenna coil (AC0, AC1)	6
2.2	Ground (VSS), only available on ST25TA02KB-P and ST25TA02KB-D	6
2.3	GPO supply voltage (VDCG), only available on ST25TA02KB-P	6
2.3.1	Operating supply voltage VDCG	6
2.3.2	Power-up conditions	6
2.4	General purpose output (GPO), only available on ST25TA02KB-P and ST25TA02KB-D ...	6
3	ST25TAxxxB memory management	7
3.1	Memory structure	7
3.1.1	File identifier	7
3.1.2	CC file layout	7
3.1.3	NDEF file layout	8
3.1.4	System file layout	9
3.2	Read and write access rights to the NDEF file	10
3.2.1	Read and Write protection modes	11
3.2.2	Read and Write access conditions	11
3.2.3	Changing the read protection mode	12
3.2.4	Changing the write protection mode	12
3.3	Granted access life time	13
3.4	NDEF file passwords	13
4	Specific features	14
4.1	Read/Write counter	14
4.2	General purpose output (GPO), only available on ST25TA02KB-D/P	14
4.2.1	Inactive configuration (GPO field = 0x00 or 0x80)	14
4.2.2	Session Open configuration (GPO field = 0x10 or 0x90)	15
4.2.3	WIP Writing in Progress configuration (GPO field = 0x20 or 0xA0)	16
4.2.4	MIP NDEF Message writing in Progress configuration (GPO field = 0x30 or 0xB0)	17

4.2.5	INT Interrupt configuration (GPO field = 0x40 or 0xC0)	18
4.2.6	State Control configuration (GPO field = 0x50 or 0xD0)	19
4.2.7	RF busy configuration (GPO field = 0x60 or 0xE0)	20
4.2.8	Field detect configuration (GPO field = 0x70 or 0xF0)	21
4.3	TruST25™ digital signature feature	21
5	Communication mechanism	22
5.1	Master and slave	22
6	RF command sets	23
6.1	Structure of the command sets	24
6.2	I-Block format.	24
6.2.1	C-APDU: payload format of a command	25
6.2.2	R-APDU: payload format of a response	26
6.3	R-Block format.	26
6.4	S-Block format.	27
6.5	CRC of the RF frame	29
6.6	Status and error codes	29
6.7	NFC Forum Type 4 Tag protocol	30
6.7.1	NDEF Tag Application Select command	30
6.7.2	Capability Container Select command	31
6.7.3	NDEF Select command.	31
6.7.4	System File Select command	32
6.7.5	ReadBinary command.	32
6.7.6	UpdateBinary command	33
6.8	ISO/IEC 7816-4 commands	34
6.8.1	Verify command	34
6.8.2	Change Reference Data command	35
6.8.3	Enable Verification Requirement command.	36
6.8.4	Disable Verification Requirement command	37
6.9	ST-proprietary command set	38
6.9.1	ExtendedReadBinary command	38
6.9.2	EnablePermanentState command.	38

6.9.3	UpdateFileType command	39
6.9.4	SendInterrupt command	40
6.9.5	StateControl command	40
6.10	ISO14443-4 / NFC-A command set	42
6.10.1	Anticollision command set	42
6.10.2	RATS command and ATS response	43
6.10.3	PPS command and response	44
6.10.4	DESELECT command	44
7	Functional procedures	45
7.1	Protecting an NDEF file	45
7.2	Accessing a protected NDEF file	45
7.3	Unprotecting an NDEF file	45
7.4	Locking an NDEF file	45
7.5	Reaching the READ-ONLY state	45
7.6	Changing a password	45
7.7	Changing the file type	46
8	UID: unique identifier	47
9	Maximum ratings	48
10	GPO characteristics	49
10.1	CMOS GPO characteristics (ST25TA02KB-P only)	49
10.2	Open drain GPO characteristics (ST25TA02KB-D only)	50
11	GPO parameters	51
12	RF electrical parameters	52
13	Package information	53
13.1	UFDFPN5 package information	53
14	Ordering information	54
	Revision history	55
	Contents	56
	List of tables	59
	List of figures	61

List of tables

Table 1.	Signal names	3
Table 2.	Functional mode	4
Table 3.	File identifier	7
Table 4.	CC file layout	7
Table 5.	NDEF file layout	8
Table 6.	Field list	9
Table 7.	Details about the Counter configuration field	10
Table 8.	Details about the GPO field	10
Table 9.	Read protection modes	11
Table 10.	Write protection modes	11
Table 11.	Read access conditions (CCRD values)	11
Table 12.	Write access conditions (CCWR values)	11
Table 13.	RF command sets	23
Table 14.	I-Block format	24
Table 15.	PCB field of the I-Block format	24
Table 16.	C-APDU format	25
Table 17.	R-APDU format	26
Table 18.	R-Block format	26
Table 19.	PCB field of the R-Block format	27
Table 20.	S-Block format	27
Table 21.	PCB field of the S-Block format	28
Table 22.	Status code of the ST25TAXxxB	29
Table 23.	Error codes of the ST25TAXxxB	29
Table 24.	C-APDU of the NDEF Tag Application Select command	30
Table 25.	R-APDU of the NDEF Tag Application Select command	30
Table 26.	C-APDU of the Capability Container Select command	31
Table 27.	R-APDU of the Capability Container Select command	31
Table 28.	C-APDU of the NDEF Select command	31
Table 29.	R-APDU of the NDEF Select command	32
Table 30.	C-APDU of the System File Select command	32
Table 31.	R-APDU of the System File Select command	32
Table 32.	C-APDU of the ReadBinary command	33
Table 33.	R-APDU of the ReadBinary command	33
Table 34.	C-APDU of the UpdateBinary command	33
Table 35.	R-APDU of the UpdateBinary command	34
Table 36.	C-APDU of the Verify command	34
Table 37.	R-APDU of the Verify command	35
Table 38.	C-APDU of the Change Reference Data command	35
Table 39.	R-APDU of the Change Reference Data command	36
Table 40.	C-APDU of the Enable Verification Requirement command	36
Table 41.	R-APDU of the Enable Verification Requirement command	37
Table 42.	C-APDU of the Disable Verification Requirement command	37
Table 43.	R-APDU of the Disable Verification Requirement command	38
Table 44.	C-APDU of the ExtendedReadBinary command	38
Table 45.	C-APDU of the EnablePermanentState command	39
Table 46.	R-APDU of the EnablePermanentState command	39
Table 47.	C-APDU of the UpdateFileType command	39
Table 48.	R-APDU of the UpdateFileType command	40
Table 49.	C-APDU of the SendInterrupt command	40
Table 50.	R-APDU of the SendInterrupt command	40
Table 51.	C-APDU of the StateControl command	41
Table 52.	R-APDU of the StateControl command	41

Table 53.	Commands issued by the RF host	42
Table 54.	Example of anticollision sequence	42
Table 55.	RATS command	43
Table 56.	Conversion from FSDI to FSD	43
Table 57.	ATS response	43
Table 58.	PPS command	44
Table 59.	Ascending and descending data rate coding	44
Table 60.	PPS response	44
Table 61.	UID format	47
Table 62.	Absolute maximum ratings	48
Table 63.	CMOS GPO operating conditions	49
Table 64.	CMOS GPO DC characteristics	49
Table 65.	CMOS GPO AC Characteristics	49
Table 66.	Open drain GPO operating conditions	50
Table 67.	Open drain GPO DC characteristics	50
Table 68.	GPO timings measurement	51
Table 69.	Default operating conditions	52
Table 70.	RF characteristics	52
Table 71.	UFDFPN5 - 5-lead, 1.7 × 1.4 mm, 0.55 mm thickness package mechanical data	53
Table 72.	Ordering information scheme	54
Table 73.	Document revision history	55

List of figures

Figure 1.	Block diagram - ST25TA02KB and ST25TA512B	2
Figure 2.	Block diagram - ST25TA02KB-P	2
Figure 3.	Block diagram - ST25TA02KB-D	3
Figure 4.	5-pin package connections - ST25TA02KB-D	3
Figure 5.	5-pin package connections - ST25TA02KB-P	3
Figure 6.	Applicative example of GPO usage - ST25TA02KB-D	4
Figure 7.	Applicative example of GPO usage - ST25TA02KB-P	5
Figure 8.	Changing the read protection mode	12
Figure 9.	Changing the write protection mode	12
Figure 10.	CMOS GPO configured as Session Open (GPO field = 0x10 or 0x90)	15
Figure 11.	Open drain GPO configured as Session Open (GPO field = 0x10 or 0x90)	15
Figure 12.	CMOS GPO configured as WIP (GPO field = 0x20 or 0xA0)	16
Figure 13.	Open drain GPO configured as WIP (GPO field = 0x20 or 0xA0)	16
Figure 14.	CMOS GPO configured as MIP (GPO field = 0x30 or 0xB0)	17
Figure 15.	Open drain GPO configured as MIP (GPO field = 0x30 or 0xB0)	17
Figure 16.	CMOS GPO configured as INT (GPO field = 0x40 or 0xC0)	18
Figure 17.	Open drain GPO configured as INT (GPO field = 0x40 or 0xC0)	18
Figure 18.	CMOS GPO configured as State Control (GPO field = 0x50 or 0xD0)	19
Figure 19.	Open drain GPO configured as State Control (GPO field = 0x50 or 0xD0)	19
Figure 20.	CMOS GPO configured as RF busy (GPO field = 0x60 or 0xE0)	20
Figure 21.	Open drain GPO configured as RF busy (GPO field = 0x60 or 0xE0)	20
Figure 22.	CMOS GPO configured as Field detect (GPO field = 0x70 or 0xF0)	21
Figure 23.	Open drain GPO configured as Field detect (GPO field = 0x70 or 0xF0)	21
Figure 24.	UFDFPN5 - 5-lead, 1.7 × 1.4 mm, 0.55 mm thickness package outline	53



IMPORTANT NOTICE – PLEASE READ CAREFULLY

STMicroelectronics NV and its subsidiaries (“ST”) reserve the right to make changes, corrections, enhancements, modifications, and improvements to ST products and/or to this document at any time without notice. Purchasers should obtain the latest relevant information on ST products before placing orders. ST products are sold pursuant to ST’s terms and conditions of sale in place at the time of order acknowledgement.

Purchasers are solely responsible for the choice, selection, and use of ST products and ST assumes no liability for application assistance or the design of Purchasers’ products.

No license, express or implied, to any intellectual property right is granted by ST herein.

Resale of ST products with provisions different from the information set forth herein shall void any warranty granted by ST for such product.

ST and the ST logo are trademarks of ST. All other product or service names are the property of their respective owners.

Information in this document supersedes and replaces information previously supplied in any prior versions of this document.

© 2018 STMicroelectronics – All rights reserved



Компания «ЭлектроПласт» предлагает заключение долгосрочных отношений при поставках импортных электронных компонентов на взаимовыгодных условиях!

Наши преимущества:

- Оперативные поставки широкого спектра электронных компонентов отечественного и импортного производства напрямую от производителей и с крупнейших мировых складов;
- Поставка более 17-ти миллионов наименований электронных компонентов;
- Поставка сложных, дефицитных, либо снятых с производства позиций;
- Оперативные сроки поставки под заказ (от 5 рабочих дней);
- Экспресс доставка в любую точку России;
- Техническая поддержка проекта, помощь в подборе аналогов, поставка прототипов;
- Система менеджмента качества сертифицирована по Международному стандарту ISO 9001;
- Лицензия ФСБ на осуществление работ с использованием сведений, составляющих государственную тайну;
- Поставка специализированных компонентов (Xilinx, Altera, Analog Devices, Intersil, Interpoint, Microsemi, Aeroflex, Peregrine, Syfer, Eurofarad, Texas Instrument, Miteq, Cobham, E2V, MA-COM, Hittite, Mini-Circuits, General Dynamics и др.);

Помимо этого, одним из направлений компании «ЭлектроПласт» является направление «Источники питания». Мы предлагаем Вам помощь Конструкторского отдела:

- Подбор оптимального решения, техническое обоснование при выборе компонента;
- Подбор аналогов;
- Консультации по применению компонента;
- Поставка образцов и прототипов;
- Техническая поддержка проекта;
- Защита от снятия компонента с производства.



Как с нами связаться

Телефон: 8 (812) 309 58 32 (многоканальный)

Факс: 8 (812) 320-02-42

Электронная почта: org@eplast1.ru

Адрес: 198099, г. Санкт-Петербург, ул. Калинина, дом 2, корпус 4, литера А.