



Single-Cell NiMH Charger

DS2710

General Description

The DS2710 is ideal for in-system charging of single-cell nickel metal hydride (NiMH) cells for low-current portable applications. Inputs to the DS2710 include USB voltage sources and 5V regulated adapters. Temperature, voltage, and charge time are monitored to provide proper fast-charging control algorithms for single-cell NiMH or nickel cadmium (NiCd) batteries. The DS2710 includes battery tests to detect defective or inappropriate cells such as alkaline primary batteries.

Applications

- Small Rechargeable Devices
- Voice Recorders
- Cordless Mouse
- Battery-Powered Toys

Features

- ◆ Charges Single-Cell NiMH Cells
- ◆ Switch-Mode Topologies Supported by Hysteretic Control Technique
- ◆ Precharges Deeply Depleted Cells
- ◆ Fast-Charges NiMH with $-\Delta V$ Termination Sensitivity of 2mV (typ)
- ◆ Monitors Voltage, Temperature, and Time for Safety and Secondary Termination
- ◆ Regulates Charge Current
- ◆ Designed for External pMOS
- ◆ Rail-to-Rail MOSFET Driver
- ◆ Tiny 10-Pin TDFN Package (3mm x 4mm)

Ordering Information

PART	PIN-PACKAGE
DS2710G+	10 TDFN-EP*
DS2710G+T&R	10 TDFN-EP*

+ Denotes a lead(Pb)-free/RoHS-compliant package.
 T&R = Tape and reel.
 *EP = Exposed pad.

Typical Operating Circuit

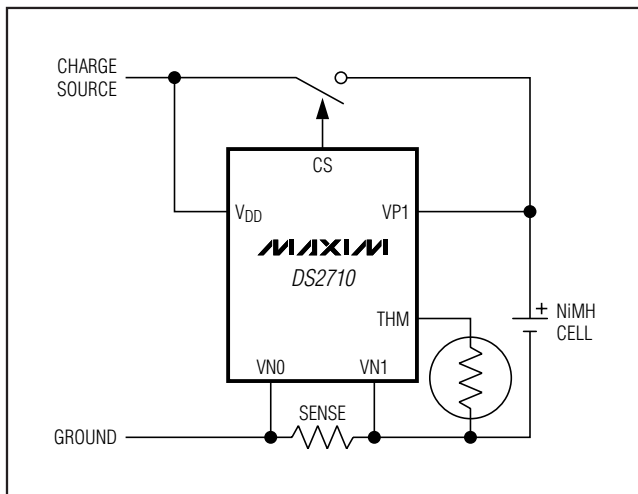

Pin Configuration

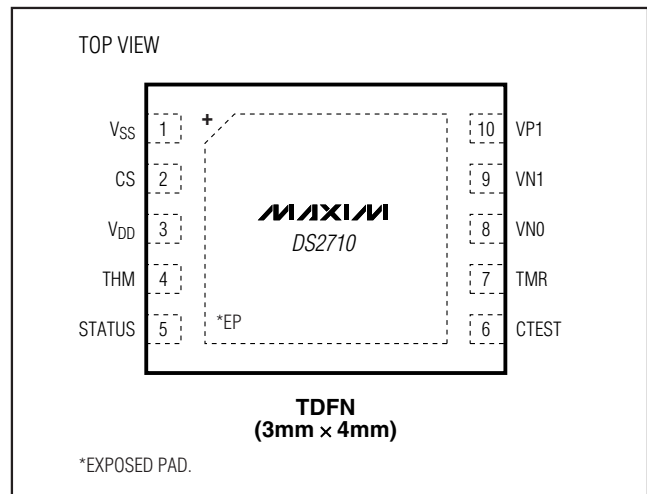

Single-Cell NiMH Charger

ABSOLUTE MAXIMUM RATINGS

Voltage Range on All Pins Relative to V_{SS} -0.3V to +6.0V
 Continuous Source/Sink Current CS.....20mA
 Continuous Source Current STATUS10mA

Operating Temperature Range-40°C to +85°C
 Storage Temperature Range-55°C to +125°C
 Soldering Temperature.....Refer to the IPC/JEDEC
 J-STD-020 Specification.

Stresses beyond those listed under "Absolute Maximum Ratings" may cause permanent damage to the device. These are stress ratings only, and functional operation of the device at these or any other conditions beyond those indicated in the operational sections of the specifications is not implied. Exposure to absolute maximum rating conditions for extended periods may affect device reliability.

RECOMMENDED DC OPERATING CONDITIONS

($4.0V \leq V_{DD} \leq 5.5V$, $T_A = -20^\circ C$ to $+70^\circ C$.)

PARAMETER	SYMBOL	CONDITIONS	MIN	TYP	MAX	UNITS
Supply Voltage	V_{DD}	(Note 1)	4.0		5.5	V
Input Voltage Range		CTEST, TMR, THM, VP1, VN1	-0.3		V_{DD}	V

DC ELECTRICAL CHARACTERISTICS

($4.0V \leq V_{DD} \leq 5.5V$, $T_A = -20^\circ C$ to $+70^\circ C$, unless otherwise noted.)

PARAMETER	SYMBOL	CONDITIONS	MIN	TYP	MAX	UNITS
Supply Current, V_{DD}	I_{DD}	Operating mode (Note 2)		250	1000	μA
UVLO Threshold	V_{UVLO}	V_{DD} rising (Note 1)		3.5	3.9	V
UVLO Hysteresis	V_{UHYS}	V_{DD} falling from above V_{UVLO}	30			mV
Output-Voltage Low, CS	V_{OL1}	$V_{DD} = 5.0V$, $I_{OL} = +20mA$ (Note 1)			1.0	V
Output-Voltage High, CS	V_{OH1}	$V_{DD} = 5.0V$, $I_{OL} = -20mA$ (Note 1)	4.0			V
Output-Voltage Low, STATUS	V_{OL2}	$V_{DD} = 5.0V$, $I_{OL} = +2mA$ (Notes 1, 3)			0.50	V
Output-Voltage High, STATUS	V_{OH2}	$V_{DD} = 5.0V$, $I_{OH} = -2mA$ (Notes 1, 3)	4.0			V
Threshold Voltage, $-\Delta V$ Termination	$V_{-\Delta V}$	After t_{THO} (Note 4)	1.0	2.0	3.0	mV
Current-Sense Reference Voltage	V_{IREF}	(Notes 1, 5)		125		mV
			-6		+6	%
Hysteresis, Current-Sense Comparator	$V_{HYS-COMP}$	Centered $\sim 0.113V$	18	23	27	mV
Propagation Time, Current-Sense Comparator to Driver Output	t_{PDLY}	2mV overdrive/underdrive at trip threshold (Notes 4, 6)			0.1	μs
CS Pin Pullup Current	I_{CS}	$V_{DD} < V_{UVLO}$ (Note 4)		2	10	μA
STATUS Pin Pulldown Current	I_{STAT}	$V_{DD} < V_{UVLO}$ (Note 4)		2	10	μA
Depleted Cell Voltage Threshold	V_{LOW}	VP1 - VN1	0.9	1.0	1.1	V
Overcharge Voltage Threshold	$V_{MAX-OPEN}$	VP1 - VN1, CS = high (Note 7)	1.55	1.65	1.75	V
Open Socket Voltage Threshold	$V_{MAX-CHARGE}$	VP1 - VN1, CS = low (Note 7)	1.64	1.75	1.86	V
Offset, $V_{MAX-OPEN} - V_{MAX-CHARGE}$	V_{OS}	(Note 7)	98	100	102	mV

Single-Cell NiMH Charger

DS2710

DC ELECTRICAL CHARACTERISTICS (continued)

(4.0V ≤ V_{DD} ≤ 5.5V, T_A = -20°C to +70°C, unless otherwise noted.)

PARAMETER	SYMBOL	CONDITIONS	MIN	TYP	MAX	UNITS
Cold Temperature Detect Threshold	V _{THM-MIN}	(Notes 1, 5, 8)		0.73		V _{DD}
Hot Temperature No-Start Threshold	V _{THM-MAX}	(Notes 1, 5, 8)	0.30	0.33	0.36	V _{DD}
Hot Temperature Safety Shutdown Threshold	V _{THM-STOP}	(Notes 1, 5, 8)		0.29		V _{DD}
SUSPEND Current Threshold	I _{SUSPEND}	(Note 9)		0.1	0.5	μA
Presence-Test Current, VP1		V _{DD} ≥ 4.0V	1.0	10	15	μA
Reverse-Leakage Current, VP1		V _{DD} = 0V, V _{P1} = 1.5V			2	μA
Impedance-Voltage Test Range	V _{CTEST}		32		400	mV

ELECTRICAL CHARACTERISTICS: TIMING

(4.0V ≤ V_{DD} ≤ 5.5V, T_A = -20°C to +70°C, unless otherwise noted.)

PARAMETER	SYMBOL	CONDITIONS	MIN	TYP	MAX	UNITS
Internal Time-Base Period	t _{BASE}			0.96		Seconds
Internal Time-Base Accuracy			-10		+10	%
CS Output Duty Factor	DF1	FAST-CHARGE		96.9		%
	DF2	PRECHARGE/TOP-OFF		25.0		
	DF3	MAINTENANCE		1.56		
CELL TEST Interval	t _{CTST}			31		Seconds
PRECHARGE Timeout	t _{PCHG}	V _{CELL} < V _{LOW}		34		Minutes
FAST-CHARGE Termination Hold-Off Period	t _{THO}			4		Minutes
FAST-CHARGE Flat Voltage Timeout	t _{FLAT}	V _{CELL} not increasing		16		Minutes
Charge-Timer Period	t _{CTMR}	R _{TMR} = 40kΩ		1.0		Hours
Charge-Timer Accuracy		R _{TMR} = 40kΩ	-6		+6	%
Charge-Timer Range	t _{CTMR-RANGE}		0.5		5.0	Hours
Toggle Rate, Charging	f _{CHARGE}			1		Hz
Toggle Rate, FAULT State	f _{FAULT}			4		Hz

Note 1: Voltages relative to V_{SS}.

Note 2: Specification does not include CS and STATUS pin currents.

Note 3: STATUS pin is active high.

Note 4: Specification is guaranteed by design.

Note 5: Specification applicable during charge cycle with T_A = 0°C to +70°C.

Note 6: 50mV overdrive while connected to a pMOS transistor (such as ZXM62P02 from Zetex).

Note 7: V_{BAT-MAX1} and V_{BAT-MAX2} ranges never overlap.

Note 8: V_{THM-MIN}, V_{THM-MAX}, and V_{THM-STOP} are fixed ratios of V_{DD}. Their ranges never overlap.

Note 9: Maximum allowable leakage on TMR to maintain SUSPEND state.

Single-Cell NiMH Charger

Pin Description

PIN	NAME	FUNCTION
1	V _{SS}	Device Ground. Connects directly to the negative terminal of the charge source.
2	CS	Charge Source. Feedback control for switching circuitry.
3	V _{DD}	Power-Supply Input. Connects to the positive terminal of the charge source through a decoupling network.
4	THM	Thermistor Input. Connects to a thermistor located near the cell and a resistor-divider from the V _{DD} pin.
5	STATUS	Status Output. Drives an external LED or microprocessor input to indicate charge status.
6	CTEST	Impedance Test. Connects to V _{SS} through an external resistor to set the impedance-test threshold.
7	TMR	Fast-Charge Timer. Connects to V _{SS} through an external resistor to set the fast-charge timeout period.
8	VN0	Current-Sense Negative Input. Connects to the charge source side of the external sense resistor.
9	VN1	Current-Sense Positive Input. Connects to the cell side of the external sense resistor.
10	VP1	Cell Voltage Sense. The voltage of the cell is monitored through this input pin.
—	EP	Exposed Pad. Connects to V _{SS} .

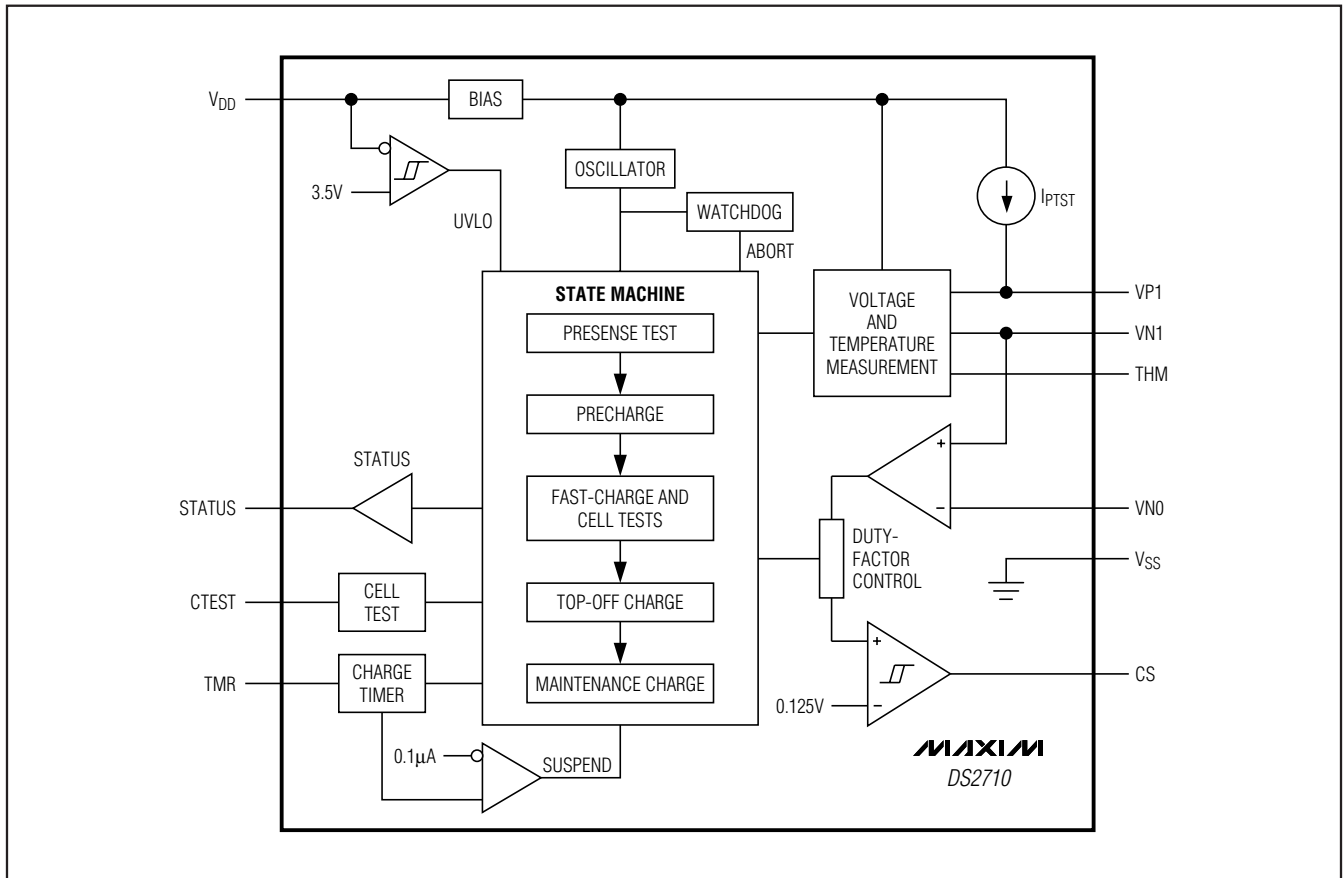

Figure 1. Block Diagram

Single-Cell NiMH Charger

Detailed Description

Charge Algorithm Overview

The DS2710 controls switch-mode topology charging of a single NiMH cell from a voltage-regulated charge source. The IC is reset in one of two ways: with the application of power to the DS2710 or after exiting SUSPEND state. Once one of these conditions occurs, the DS2710 enters the PRESENCE state and waits for a cell to be inserted before starting a charge cycle.

Once a cell is detected, the DS2710 enters PRECHARGE state and begins qualification to prevent fast charging of deeply depleted cells or charging under extreme temperature conditions. Precharging is performed at a reduced rate until the cell reaches 1V. The algorithm then proceeds to the FAST-CHARGE state, which includes cell tests to avoid accidental charging of alkaline cells or NiMH cells that are worn out or damaged. Fast charging continues as long as all the cell qualification criteria are met. Fast charging terminates by the $-\Delta V$ (negative delta voltage) method. The TOP-OFF charge phase follows to completely charge the cell. After the TOP-OFF charge timer expires, the DS2710 enters the MAINTENANCE state to indefinitely keep the cell at a full state of charge. Maximum voltage, temperature, and charge-time monitoring during all charge phases act as secondary or safety termination methods to provide additional protection from overcharge. Any error condition occurring during charge forces the DS2710 into the FAULT state and charging terminates. Charging can be halted at any time by floating the TMR pin, which forces the DS2710 into SUSPEND state.

Once a charge is complete either normally or by FAULT, the DS2710 remains in the final state (MAINTENANCE or FAULT) until the cell is removed, the IC is power cycled, or the IC is forced into SUSPEND state. Afterwards, the DS2710 returns to PRESENCE state and the charge cycle begins again.

An internal oscillator provides the main clock source used to generate timing signals for chip operation. The PRECHARGE timer, hold-off timers, and timing for CS operation and cell testing are derived from this time base. If the internal clock should ever fail, a watchdog-detection circuit halts charging. The watchdog-safety circuit and charge timer set by the TMR pin are derived from oscillators other than the main clock source. Figure 1 is the DS2710 block diagram and Figure 2 is the state diagram.

POWER-ON RESET (POR)

The UVLO circuit serves as a power-up and brownout detector by monitoring V_{DD} to prevent charging until

V_{DD} rises above V_{UVLO} , or when V_{DD} drops below $V_{UVLO} - V_{UHYS}$. If undervoltage lockout is active, charging is prevented, the state machine is forced to the POR state, and all charge timers are reset.

PRESENCE

The DS2710 enters the PRESENCE state whenever the TMR pin is not floating and $V_{DD} > V_{UVLO}$, indicating that the charge source is present. The DS2710 remains in the PRESENCE state until a cell is inserted into the circuit, causing the voltage of VP1 - VN1 to fall below 1.65V ($V_{MAX-OPEN}$) and the cell temperature is inside a valid charging range between 0°C and +45°C ($T_{THM-MIN}$ and $T_{THM-MAX}$ when used with recommended thermistor and resistor values). If both these conditions are met, the DS2710 enters PRECHARGE. If a cell is inserted but the temperature is outside the valid charging range, the DS2710 remains in the PRESENCE state until the cell temperature falls within the valid charging range.

PRECHARGE

The DS2710 enters the PRECHARGE state when a valid cell voltage is detected and the cell temperature as measured by the DS2710 thermistor circuit is within the valid charging range. The DS2710 precharges the cell by regulating the voltage drop across the sense resistor to 113mV with a 25% duty cycle. The STATUS output toggles at 1Hz to indicate the cell is being precharged. Precharging lasts until the measured cell voltage exceeds 1.0V (V_{LOW}), at which time the DS2710 enters the FAST-CHARGE state. If the cell voltage does not exceed V_{LOW} within 30min (t_{PCHG}) or if the cell temperature exceeds +50°C ($T_{THM-STOP}$) at any time during PRECHARGE, the DS2710 enters the FAULT state. If at any time during PRECHARGE the cell voltage exceeds 1.75V ($V_{MAX-CHARGE}$), the DS2710 determines that the cell has been removed and enters the FAULT state.

FAST-CHARGE

In the FAST-CHARGE state, the DS2710 regulates the average voltage across the sense resistor to 113mV. The STATUS output is held high to indicate the cell pack is being charged. During FAST-CHARGE, the DS2710 performs a cell test every 31s. The CELL TEST state is responsible for determining when charge is complete. As secondary overcharge protection, the DS2710 terminates FAST-CHARGE and enters TOP-OFF based on a time delay set by the external resistor on the TMR pin. This resistor value can set the secondary charge termination delay to anywhere from 30min up to 5hr. If the cell temperature exceeds +50°C at any time during FAST-CHARGE, the DS2710 enters

Single-Cell NiMH Charger

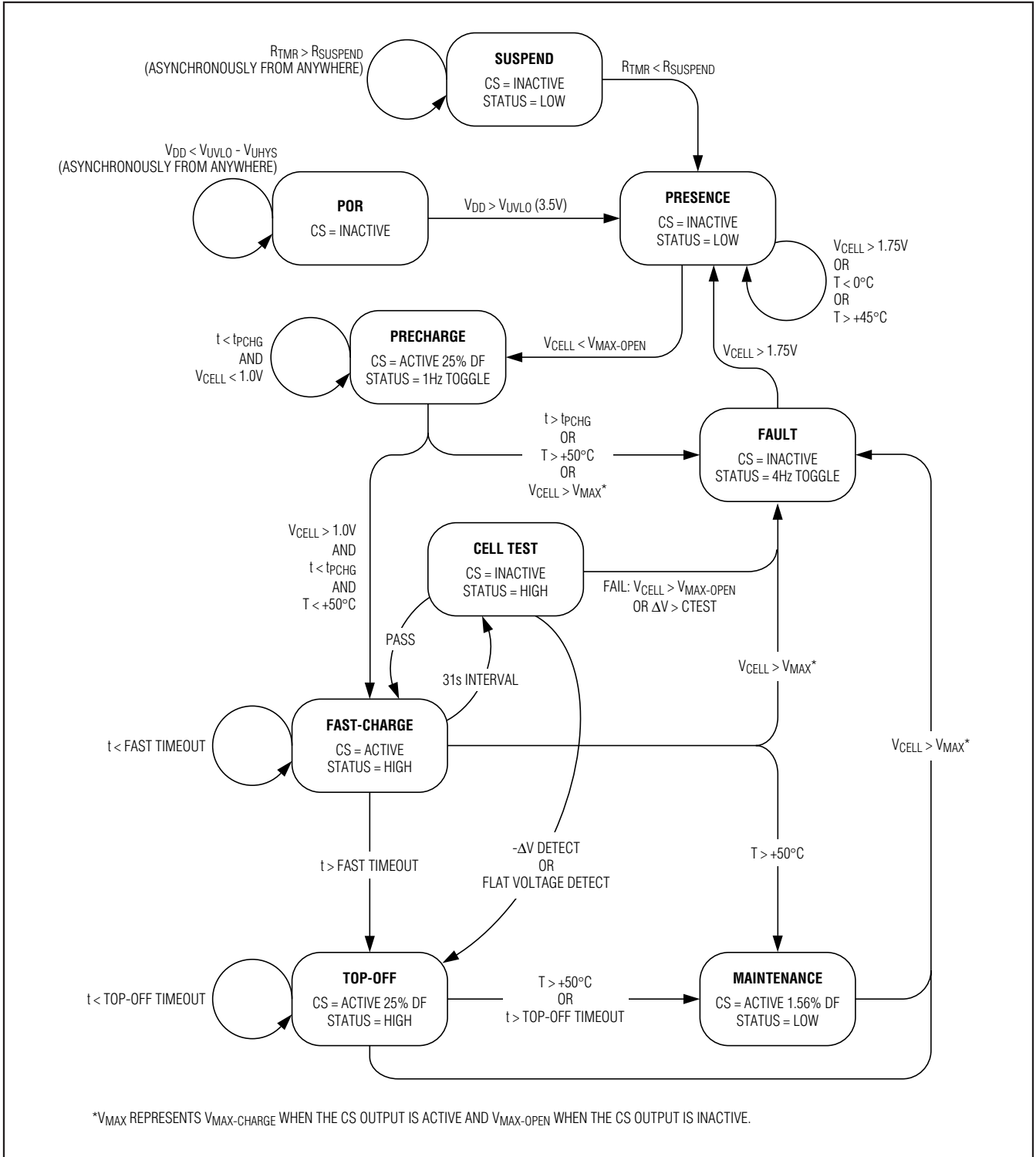

Figure 2. State Diagram

Single-Cell NiMH Charger

the MAINTENANCE state. If at any time during FAST-CHARGE the cell voltage exceeds $V_{MAX-CHARGE}$, the DS2710 determines that the cell is either overcharged or has been removed, and enters the FAULT state.

CELL TEST

CELL TEST is performed once every 31s during FAST-CHARGE to determine if charging is complete. During CELL TEST, the CS output is held high to prevent charging. The cell's voltage is measured and compared against prior readings. The maximum cell voltage measurement during the charge is retained. If a cell's voltage falls more than 2mV ($V_{-ΔV}$) from its peak reading, the FAST-CHARGE terminates successfully and moves to TOP-OFF. The DS2710 also moves to TOP-OFF if the cell's voltage reading does not exceed the maximum over a 16min period (t_{FLAT}). A hold-off period for $-ΔV$ and flat voltage detection begins at the start of fast charging and prevents false termination in the first 4min of the charge cycle (t_{THO}).

The impedance of the cell is also measured during CELL TEST. The cell's open-circuit voltage is compared against the voltage of the cell under charge. The difference is compared against the impedance threshold set by the CTEST pin. If the difference exceeds the threshold set by CTEST, the cell's impedance is considered to be too high for charging and the DS2710 enters the FAULT state. The DS2710 also enters FAULT state if any voltage reading in CELL TEST exceeds the $V_{MAX-OPEN}$ threshold.

TOP-OFF

In the TOP-OFF state, the DS2710 charges at 25% the rate of FAST-CHARGE. The voltage across the sense resistor is regulated to 113mV with a 25% duty cycle. The STATUS output is held high to indicate the cell pack is being charged. The charge timer is reset and restarted with a timeout period of one-half the FAST-CHARGE duration. When the charge timer expires or if the measured temperature exceeds $+50^{\circ}\text{C}$, the charger enters the MAINTENANCE state. If

the cell voltage is greater than $V_{MAX-CHARGE}$ during the 25% of time when charge current is applied or $V_{MAX-OPEN}$ during the remaining time, TOP-OFF is exited early and the DS2710 goes to FAULT.

MAINTENANCE

The DS2710 enters the MAINTENANCE state whenever the charge completes normally or if the measured cell temperature exceeds $+50^{\circ}\text{C}$ during the charge. The STATUS pin is driven low to indicate TOP-OFF has completed. The cell's state of charge is maintained indefinitely by continuing a 1.56% duty-cycle charge of the cell. The DS2710 remains in the MAINTENANCE state until the cell is removed, the DS2710 is power cycled, or the DS2710 is forced into SUSPEND state.

FAULT

The DS2710 can enter FAULT from any charge state if the cell voltage exceeds $V_{MAX-CHARGE}$ any time when charge current is applied (CS low) or $V_{MAX-OPEN}$ at any time when no charge current is flowing (CS high). In addition, FAULT can be entered during PRECHARGE if the cell's temperature exceeds $+50^{\circ}\text{C}$ or the PRECHARGE timer expires, or during FAST-CHARGE if impedance threshold is exceeded. In the FAULT state, CS is forced high to prevent charging and the STATUS output toggles at a 4Hz rate to indicate that an error has occurred. The DS2710 remains in FAULT until a cell voltage greater than 1.75V ($V_{MAX-CHARGE}$) is detected, indicating that the cell has been removed. The DS2710 then enters the PRESENCE state and waits for the next cell insertion.

SUSPEND

Suspension of charge activity is possible by floating the TMR pin ($R_{TMR} > R_{SUSPEND}$). The CS output is pulled to V_{DD} to disable the charge control FET to prevent current flow to the cell. When the TMR connection is restored, charging begins from the PRESENCE state with all timers reset. The SUSPEND state is useful as a means to stop charging by the application circuit, such as with a microcontroller signal.

Single-Cell NiMH Charger

Charge-Current Regulation

The DS2710 regulates charge current by maintaining a constant average voltage across an external sense resistor connected between the VN1 and VN0 pins. VN1 and VN0 drive an internal comparator in the DS2710 to switch the CS output ON and OFF to drive a regulating pnp bipolar or a pMOS transistor. Hysteresis on the comparator input provides noise rejection. The DS2710 regulates the charge current during FAST-CHARGE to maintain a voltage drop across the sense resistor as follows:

$$V_{SENSE} = V_{REF} - 0.5 \times V_{HYS-COMP} = 0.113V \text{ (typ)}$$

Figure 3 shows the sense resistor voltage and CS pin voltage of the regulating circuit during normal operation.

Charging with Load Applied

NiMH cells have a low, but finite, impedance. If load current is flowing out of the battery, an internal voltage drop appears at the battery terminals. This can interfere with the CTEST and $-\Delta V$ detection. If the load current is variable, early termination is more likely than if the load current is constant. If the load's ground is connected to the negative terminal of the cell (VN0), load current flows through the current-sense resistor, resulting in less

charge current to the battery. The load-current return path should be to charger ground to reduce the likelihood of false termination or impedance-test errors. Charging with load applied is not recommended.

Temperature Monitoring

Accurate temperature sensing is needed to detect temperature FAULT conditions. Connecting an external 10k Ω NTC thermistor between THM and V_{SS} and a 10k Ω bias resistor between V_{DD} and THM allows the DS2710 to sense temperature. To accurately monitor the cell, the thermistor should make physical contact either to the cell or cell tabs. Table 1 shows several recommended 10k Ω thermistors.

MIN, MAX Temperature Compare

The voltage thresholds of the THM input ($V_{THM-MIN}$, $V_{THM-MAX}$) are set to allow charging to start if the thermistor temperature is between 0°C and +45°C when using the recommended 10k Ω bias resistor and 10k Ω thermistor circuit. If precharging is in progress and the voltage on THM reaches $V_{THM-STOP}$, precharging stops and a FAULT condition is generated. If the voltage on THM reaches $V_{THM-STOP}$ during FAST-CHARGE or TOP-OFF, charging stops and the DS2710 enters the MAINTENANCE state. FAST-CHARGE and

Table 1. THM Thresholds

THM THRESHOLD	RATIO OF V _{CBIAS}	THERMISTOR RESISTANCE (k Ω)	TEMPERATURE (°C)	
			Semitec 103AT-2	Fenwal 197-103LAG-A01, 173-103LAF-301
MIN	0.73	27.04	0	+4
MAX	0.33	4.925	+45	+42
STOP	0.29	4.085	+50	+47

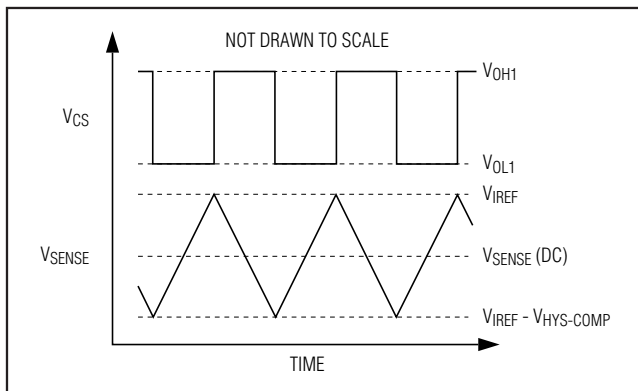

Figure 3. Ideal Comparator Input and Charge Control Output Waveforms

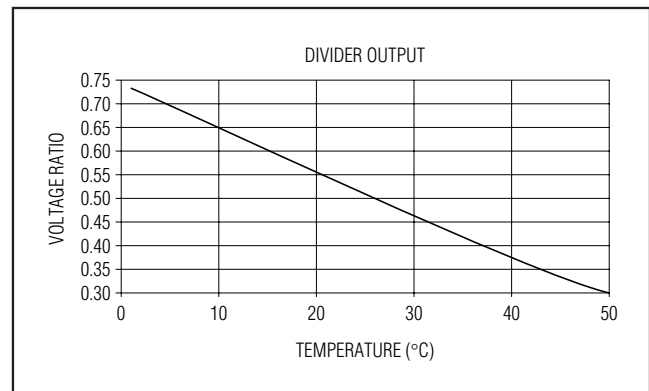

Figure 4. Ratio of THM Pin to V_{DD} Pin Over Temperature

Single-Cell NiMH Charger

TOP-OFF complete normally if the cell temperature remains below this threshold.

Used with a 10kΩ resistor, the Semitec 103AT-2 provides approximately 0.9% full scale-per-degree sensitivity. Figure 4 shows this linearity curve. The left axis is the ratio of the sensed voltage to the divider's input voltage (VDD).

Charge-Status Output

The DS2710 indicates the state of charge and the charge results on the STATUS output pin. When no cell is present, the output is driven to a logic-low. Any LED attached to the STATUS pin is off. When a cell is inserted, STATUS oscillates in a 1Hz, 50% duty-cycle pattern to indicate the cell is precharging. Once the DS2710 transitions to FAST-CHARGE, the STATUS output goes to logic-high and stays high until the end of TOP-OFF. STATUS returns to logic-low for MAINTENANCE charge and remains at logic-low until the cell is removed or the DS2710 is power cycled. If a FAULT occurs during charging, STATUS toggles at a fast 4Hz, 50% duty-cycle rate until the cell is removed. Table 2 summarizes

the STATUS output and LED operation for each charge condition.

Charge-Rate Selection

The charge rate is determined by an external sense resistor connected between the VN1 and VN0 pins. The DS2710 regulates the charge current to maintain a voltage drop of $V_{IREF} - 0.5 \times V_{HYS-COMP}$ across the sense resistor during FAST-CHARGE:

$$V_{SENSE} = V_{IREF} - 0.5 \times V_{HYS-COMP} = 0.113V \text{ (typ)}$$

The sense resistor can therefore be selected by:

$$R_{SENSE} = 0.113V / \text{Desired FAST-CHARGE Current}$$

The effective FAST-CHARGE rate is equal to 0.969 times the regulated current limit, TOP-OFF rate is 0.25 times the regulated current, and MAINTENANCE charge rate is 0.0156 times the regulated current. Table 3 shows the charge rates for charging three different cell capacities using a 565mA (0.200Ω sense) current source and a 1130mA (0.100Ω sense) current source.

Table 2. LED Display Patterns Based on Charge State

	CHARGE STATE				
	NO BATTERY	PRECHARGE	FAST-CHARGE/ TOP-OFF	MAINTENANCE	FAULT
STATUS PIN	Logic-low	Oscillates at 1Hz, 50% duty cycle	Logic-high	Logic-low	Oscillates at 4Hz, 50% duty cycle
STATUS PIN LED	Off	1Hz toggle	On	Off	4Hz toggle

Table 3. Charge-Rate Examples

STATE	565mA CHARGE RATE (0.200Ω) AT CELL CAPACITY			1130mA CHARGE RATE (0.100Ω) AT CELL CAPACITY		
	900mAH	1700mAH	2200mAH	900mAH	1700mAH	2200mAH
FAST-CHARGE	C/1.64	C/3.10	C/4.00	C/0.82	C/1.55	C/2.0
PRECHARGE/TOP-OFF	C/6.37	C/12.0	C/15.5	C/3.19	C/6.0	C/7.75
MAINTENANCE	C/102	C/193	C/249	C/51	C/96	C/125

Single-Cell NiMH Charger

Timeout Selection

FAST-CHARGE state normally operates until $-\Delta V$ termination. In the event that termination does not occur correctly, a safety timeout is required. This timeout is set by an external resistor on the TMR pin to V_{SS} and provides secondary protection against significant overcharging. The value of the TMR resistor should be chosen so that the timeout is greater than the FAST-CHARGE time expected in the application, but not so much greater that its protection is compromised. If the timer expires during FAST-CHARGE, the timer count is reset and charging proceeds to the TOP-OFF charge state. The TMR resistor also sets the timed charge duration of TOP-OFF state. The TOP-OFF timeout period is fixed at half the FAST-CHARGE timeout period. When the timer expires in TOP-OFF, the DS2710 enters the MAINTENANCE state.

Resistors can be selected to support FAST-CHARGE timeout periods of 0.5hr to 5hr and TOP-OFF timeout periods of 0.25hr to 2.5hr. The programmed FAST-CHARGE time approximately follows the equation:

$$t(\text{minutes}) = 1.5 \times R_{\text{TMR}}(\Omega)/1000$$

Impedance-Test Threshold Selection

The DS2710 tests the cell impedance every 31s while in FAST-CHARGE state. Impedance is measured by comparing the cell voltage during normal charging to the cell voltage with no charge current (CS output held high). The resulting voltage difference is compared against the threshold set by an external resistor from CTEST to V_{SS} . The detection threshold can be set from 32mV to 400mV. The following formula approximates the setting for the detection threshold:

$$V_{\text{TEST}} = 8000/R_{\text{CTEST}} \text{ (Value in Volts)}$$

Since the charge rate is controlled by the external sense resistor (R_{SENSE}) between V_{N1} and V_{N0} , the test threshold can be expressed as impedance as follows:

$$\text{Impedance Threshold} = (8000/R_{\text{CTEST}})/(0.113/R_{\text{SENSE}}) = 70796 \times (R_{\text{SENSE}}/R_{\text{CTEST}})$$

For example, an application charging at 1.13A ($R_{\text{SENSE}} = 0.100\Omega$) would use a 47k Ω resistor on the CTEST pin to set the impedance threshold to 0.150 Ω .

Application Circuit

Figure 5 shows a typical DS2710 application circuit for charging a NiMH cell from a USB port or other 5V charge source capable of supplying 0.5A. Q1, L1, C2, and D2 form a switching buck-regulator circuit controlled by the CS pin of the DS2710. Current is regulated through the current-sense resistor, R9, by switching Q1 on and off as the sense resistor voltage ramps up and down toward the preset sense voltage thresholds. The 0.100 Ω sense resistor along with the DC ground-referenced sense threshold level of $V_{\text{REF}} - 1/2 V_{\text{HYS-COMP}}$ sets the average charge current in the example to 1.13A. The sense resistor should have a proper power rating for the chosen charge current.

The TMR resistor is set to 100k Ω for a timeout of 2.5hr. This is appropriate for cells with a capacity of approximately 2200mAh when charged with the 1.13A charge current. The CTEST resistor is set to 47k Ω for an impedance-test threshold of approximately 0.150 Ω when charging at 1.13A. Additionally, R6 protects the VP1 pin from any stress applied to the exposed tabs of a loose NiMH cell; R3 creates a weak pullup to offset the leakage through D2, which might otherwise cause a false cell detection; and R1/C1 creates a bypass filter on the V_{DD} pin of the IC.

The value of L1 in Figure 5 represents a moderate switching speed of $\sim 200\text{kHz}$ for FAST-CHARGE state. L1 can be adjusted to fit specific application goals as long as the associated change in switching speed does not exceed the circuit's ability to maintain proper regulation of the sense-resistor voltage. All capacitors should be ceramic surface-mount types of good quality where possible. The 10 μF capacitor can be of any type that meets the application requirements. All resistors not previously mentioned are standard surface-mount types.

Application PCB Layout

Proper layout rules must be followed to ensure a successful application circuit. For all modes of operation, currents in excess of 1A can flow through the charge and discharge paths (USB charging is specification limited to 500mA). All these paths should be properly sized to handle the worst-case current flow, whether from charging or from powering the load with the battery.

Switch-mode operation presents challenges with fast voltage and current transients. Proper switch-mode buck power-supply layout should always be observed.

Single-Cell NiMH Charger

DS2710

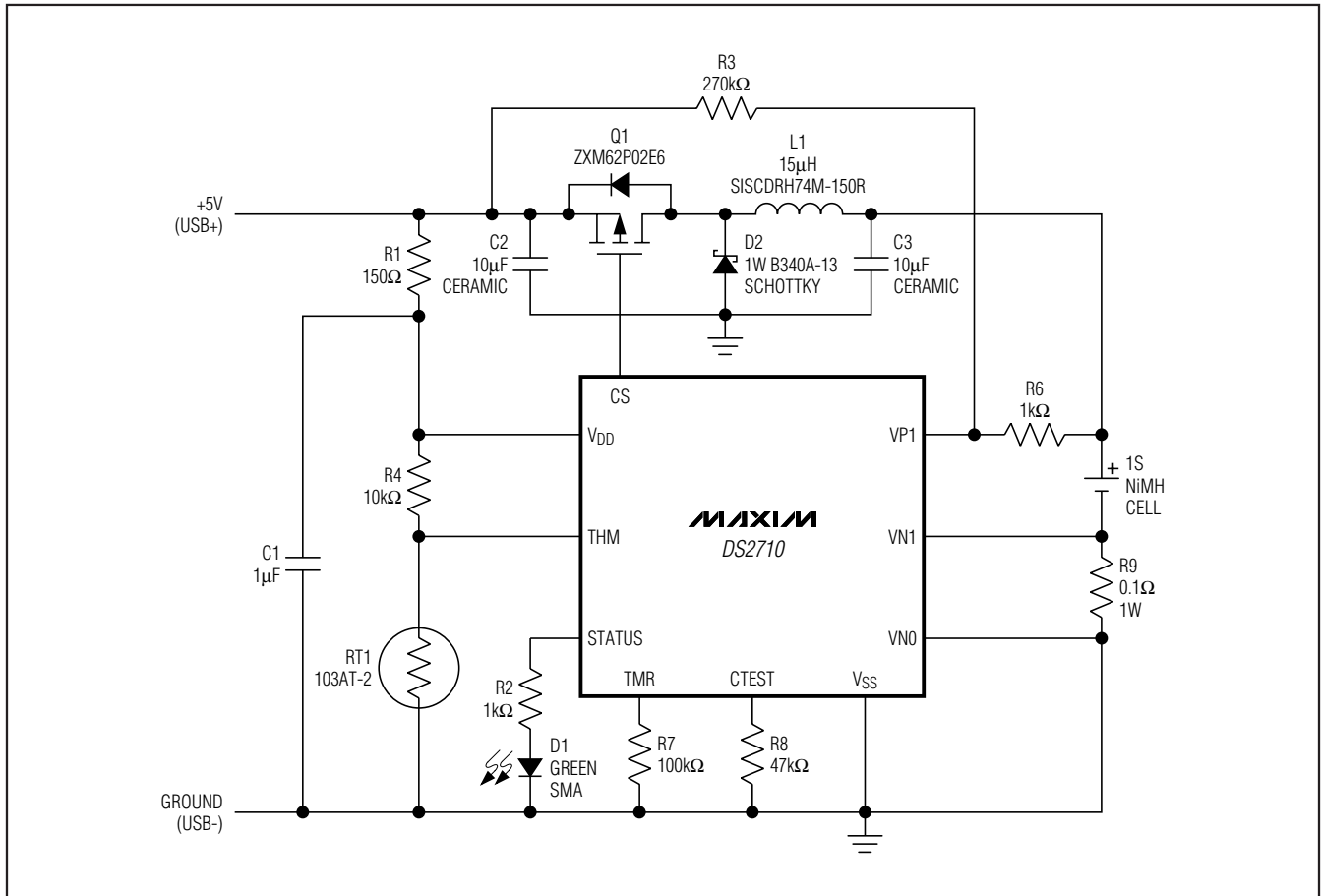

Figure 5. Typical Application Circuit for USB Port Charging

Referring to the example circuit and layout of Figure 6, the loop labeled as Loop1 encompassing C_{IN} , QSWITCH, and DSWITCH should be kept as small as possible to minimize the change in loop area that occurs when switching from the OFF to the ON state and vice versa. Loop2 should also be minimized as much as practical, although it contains DC current components for the most part. The returning ground currents should be allowed to follow a path on a layer directly under the outgoing path since the high-frequency components try to follow the path of least impedance. Low ESR and ESL capacitors should be used when possible and for all capacitors 10μF and smaller. Typical surface-mount ceramic types with an X5R or better dielectric are recommended.

Another important layout detail is the connection of the sense resistor. Proper Kelvin connection layout should be used to ensure the signal quality viewed by the sensing circuit inside the DS2710 is adequate. Figure 7 shows a recommended connection of the sense lines to the resistor footprint.

Package Information

For the latest package outline information and land patterns, go to www.maxim-ic.com/packages.

PACKAGE TYPE	PACKAGE CODE	DOCUMENT NO.
10 TDFN-EP	T1034+1	21-0268

Single-Cell NiMH Charger

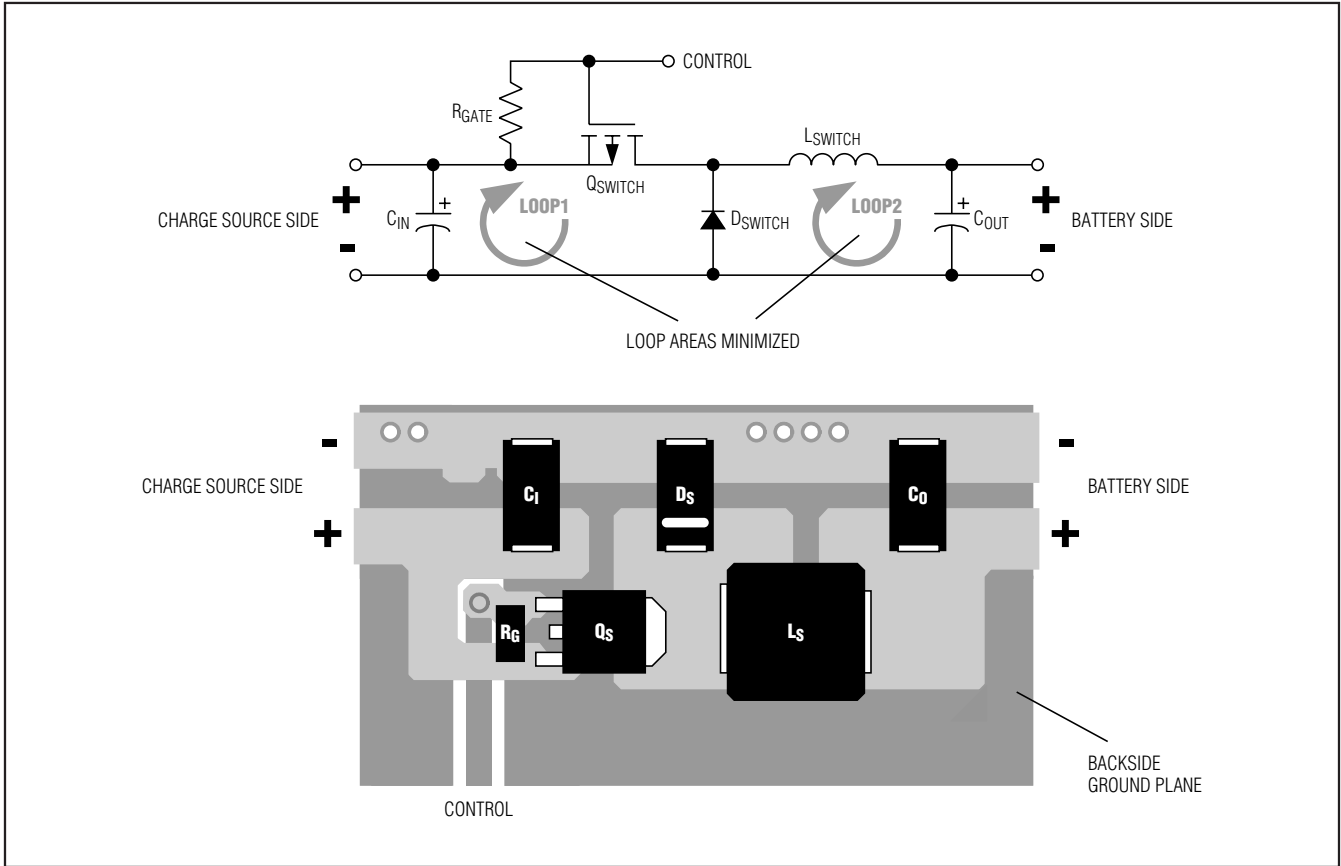

Figure 6. Switching Circuit with Example Layout

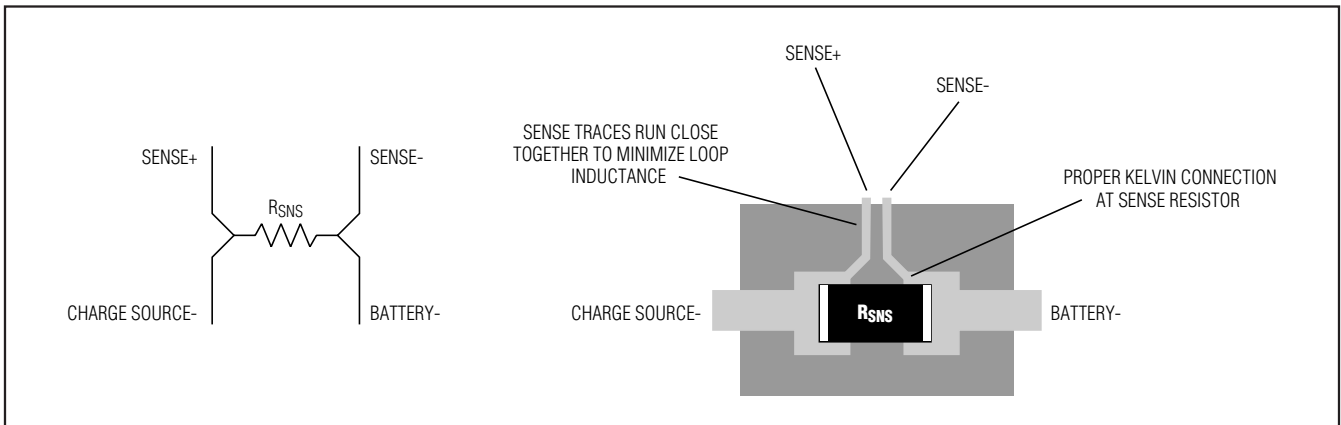

Figure 7. Sense Resistor Connection Layout

Maxim cannot assume responsibility for use of any circuitry other than circuitry entirely embodied in a Maxim product. No circuit patent licenses are implied. Maxim reserves the right to change the circuitry and specifications without notice at any time.



Компания «ЭлектроПласт» предлагает заключение долгосрочных отношений при поставках импортных электронных компонентов на взаимовыгодных условиях!

Наши преимущества:

- Оперативные поставки широкого спектра электронных компонентов отечественного и импортного производства напрямую от производителей и с крупнейших мировых складов;
- Поставка более 17-ти миллионов наименований электронных компонентов;
- Поставка сложных, дефицитных, либо снятых с производства позиций;
- Оперативные сроки поставки под заказ (от 5 рабочих дней);
- Экспресс доставка в любую точку России;
- Техническая поддержка проекта, помощь в подборе аналогов, поставка прототипов;
- Система менеджмента качества сертифицирована по Международному стандарту ISO 9001;
- Лицензия ФСБ на осуществление работ с использованием сведений, составляющих государственную тайну;
- Поставка специализированных компонентов (Xilinx, Altera, Analog Devices, Intersil, Interpoint, Microsemi, Aeroflex, Peregrine, Syfer, Eurofarad, Texas Instrument, Miteq, Cobham, E2V, MA-COM, Hittite, Mini-Circuits, General Dynamics и др.);

Помимо этого, одним из направлений компании «ЭлектроПласт» является направление «Источники питания». Мы предлагаем Вам помощь Конструкторского отдела:

- Подбор оптимального решения, техническое обоснование при выборе компонента;
- Подбор аналогов;
- Консультации по применению компонента;
- Поставка образцов и прототипов;
- Техническая поддержка проекта;
- Защита от снятия компонента с производства.



Как с нами связаться

Телефон: 8 (812) 309 58 32 (многоканальный)

Факс: 8 (812) 320-02-42

Электронная почта: org@eplast1.ru

Адрес: 198099, г. Санкт-Петербург, ул. Калинина, дом 2, корпус 4, литера А.