

APPROVAL SHEET

RFDSB Series – 1210(0504)- RoHS Compliance

**MULTILAYER CERAMIC DIFFERENTIAL SIGNAL
BALANCER**

P/N: RFDSB121013RU0T

*Contents in this sheet are subject to change without prior notice.

Approval sheet

FEATURES

- Miniature footprint: 1.25 X 1.00 X 0.83 mm³, Non-Magnetic LTCC product applying delay line technology
- Novel common mode removal by combination of absorption and time domain dispersing reflection.
- High attenuation for common mode noise over wide frequency range
- Low insertion loss and strong balance capability for high-speed differential signal.



APPLICATIONS

1. USB 3.1 GEN.2, Type C (10 Gb/s)
2. PCI Express Gen.4 (16 Gb/s)

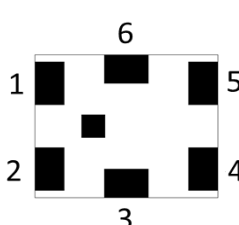
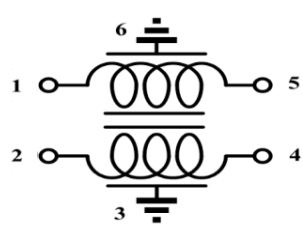
CONSTRUCTION

Figure	PIN	Connection
<p>Top view</p>  	1	IN/OUT
	2	IN/OUT
	3	GND
	4	OUT/ IN
	5	OUT/ IN
	6	GND

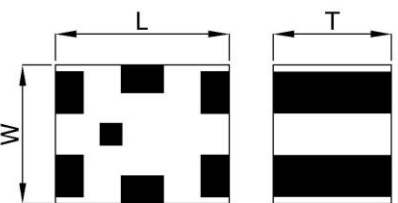
DIMENSIONS

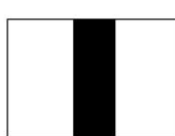
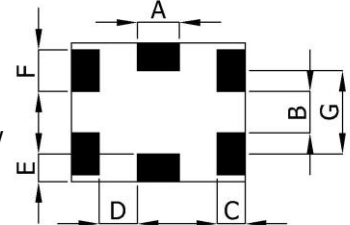
Figure	Symbol	Dimension (mm)
<p>Top view</p>  <p>Side view</p>  <p>Side view</p>  <p>Bottom view</p> 	L	1.25 ± 0.10
	W	1.00 ± 0.10
	T	0.83 ± 0.10
	A	0.30 ± 0.10
	B	0.25 ± 0.10
	C	0.20 ± 0.10
	D	0.275 ± 0.10
	E	0.20 ± 0.10
	F	0.30 ± 0.10
G	0.55 ± 0.10	

Approval sheet

ELECTRICAL CHARACTERISTICS

Item	Specification
Frequency Range	DC~12,000 MHz
Differential mode	Sdd21 -1.0 dB or more @ 5,000 MHz Sdd21 -2.0 dB or more @ 8,000 MHz
Common mode	Sc21 -15.0 dB or less @ 2,400 MHz
Insulation resistance	100 MΩ min. (DC 50 V)
DC resistance	2Ω max. pin1-pin5 and pin2-pin4
Delay time	130 ps typ.
Impedance	95±10 Ω
Temperature coefficient	Delay time : +200 ppm typ.
Moisture sensitivity levels	MSL is LEVEL 1 (Refer to : IPC/JEDEC J-STD-020)

Operating & Storage Condition (Component)

Operation Temperature Range: -40 ~ +85 °C
Storage Temperature Range: -40 ~ +85 °C

Storage Condition before Soldering (Included packaging material)

Storage Temperature Range: +5 ~ +40 °C
Humidity: 30 to 70% relative humidity

TYPICAL ELECTRICAL PERFORMANCE

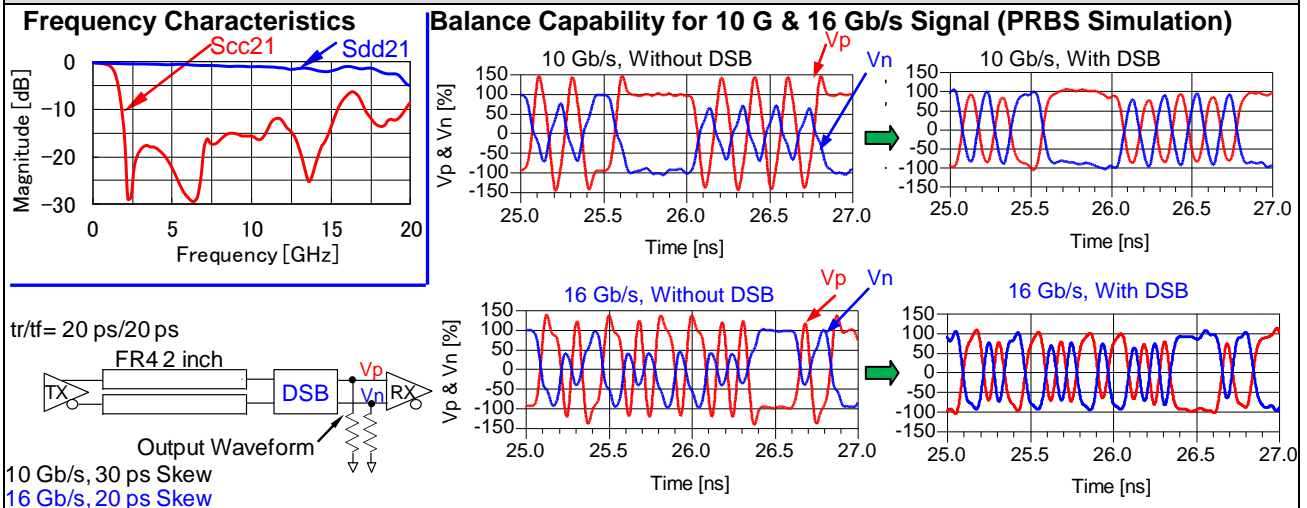

SOLDER LAND PATTERN

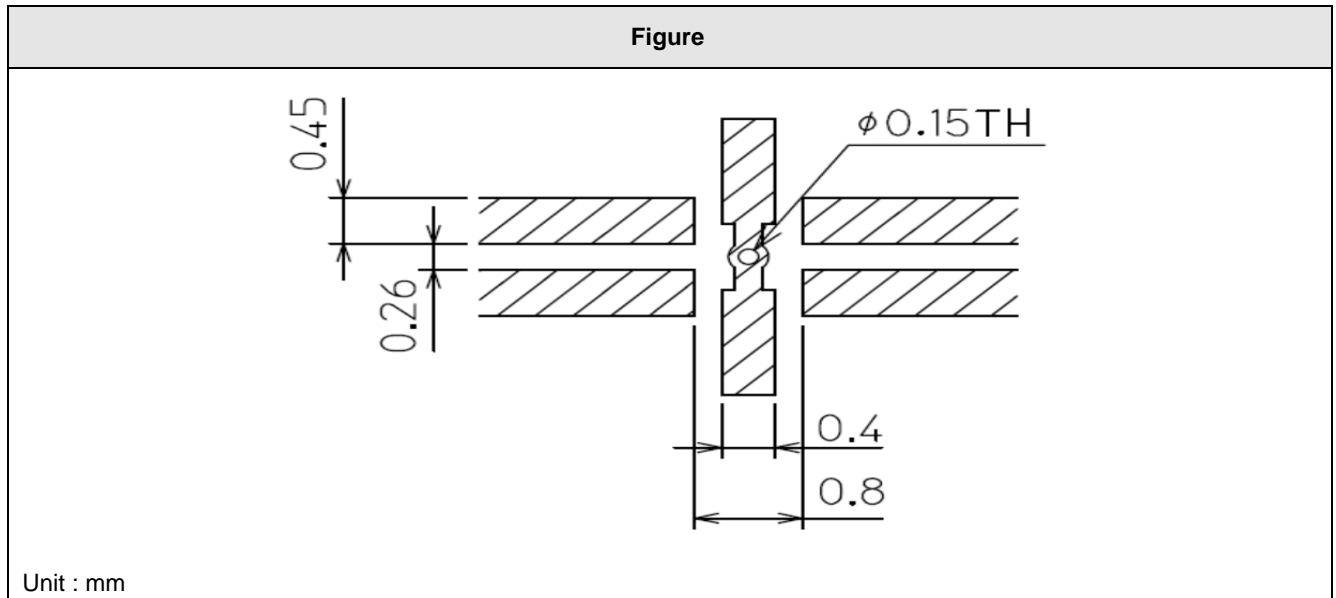

Mechanical Test

Test item	Test condition / Test method	Specification										
Solderability Ref. JIS C 0050-4.6	*Ethanol solution of rosin, 25(wt)% *Pre-Heating : 150°C, 60sec *Solder bath temperature : 245 ± 3°C *Immersion time : 3 ± 1 sec *Solder : Sn3Ag0.5Cu for lead-free	At least 95% of a surface of each terminal electrode must be covered by fresh solder.										
Resistance to soldering heat Ref. JIS C 0050-5.4	*Ethanol solution of rosin, 25(wt)% *Preheating temperature : 150°C. 60sec *Solder temperature : 270±5°C *Immersion time : 10±1 sec *Solder : Sn3Ag0.5Cu for lead-free Measurement to be made after keeping at room temperature for 4 to 48 hrs	Meet Table 1. Table 1 <table border="1"> <tr> <td>Appearance</td> <td>No damaged</td> </tr> <tr> <td>Differential mode</td> <td>Electrical specification shall satisfy the descriptions in electrical characteristics</td> </tr> <tr> <td>Common mode</td> <td>Electrical specification shall satisfy the descriptions in electrical characteristics.</td> </tr> <tr> <td>I.R.</td> <td>100MΩ min.</td> </tr> <tr> <td>DC Resistance Change</td> <td>2Ω max. pin1-pin5 and pin2-pin4</td> </tr> </table>	Appearance	No damaged	Differential mode	Electrical specification shall satisfy the descriptions in electrical characteristics	Common mode	Electrical specification shall satisfy the descriptions in electrical characteristics.	I.R.	100MΩ min.	DC Resistance Change	2Ω max. pin1-pin5 and pin2-pin4
Appearance	No damaged											
Differential mode	Electrical specification shall satisfy the descriptions in electrical characteristics											
Common mode	Electrical specification shall satisfy the descriptions in electrical characteristics.											
I.R.	100MΩ min.											
DC Resistance Change	2Ω max. pin1-pin5 and pin2-pin4											
Drop Ref. JIS C 0044	*Height : 1m *Test Surface : Rigid surface of concrete or steel. *The number of times : 3 times											
Vibration Ref. JIS C 0040	*Frequency : 10Hz~55Hz~10Hz(1min) *Total amplitude : 1.5mm *Test time : A period of 2 hours in each of 3 mutually perpendicular directions.											
Bending Strength Ref. JIS C 0051- 7.4.1	The middle part of substrate shall be pressurized by means of the pressurizing rod at a rate of about 0.5 mm/s per second until the deflection becomes 1mm and then pressure shall be maintained for 30 sec.	Meet Table 2. Table 2 <table border="1"> <tr> <td>Appearance</td> <td>No damaged</td> </tr> <tr> <td>DC Resistance Change</td> <td>2Ω max. pin1-pin5 and pin2-pin4</td> </tr> </table>	Appearance	No damaged	DC Resistance Change	2Ω max. pin1-pin5 and pin2-pin4						
Appearance	No damaged											
DC Resistance Change	2Ω max. pin1-pin5 and pin2-pin4											
Adhesive Strength of Termination JIS C 0051- 7.4.3	*Pressurizing force : 5N(≤0603) : 10N(>0603) *Test time : 10±1 sec	No remarkable damage or removal of the termination.										

Approval sheet

Environmental Performance

Test item	Test condition / Test method	Specification
Temperature cycle Ref. JIS C 0025	1. 30(+3,-0) min at -40°C(+0°C,-3°C) 2. within 3 minutes at ordinary temp. 3. 30(+3,-0) minutes at +85°C(+3°C,-0°C) 4. within 3 minutes at ordinary temp. Total 100 cycles Measurement to be made after keeping at room temperature for 4 to 48 hours	Meet Table 1.
Humidity Ref. JIS C 0022	*Humidity : 90% to 95% R.H. *Temperature : 40±2°C *Time : 1000hrs (+48/-0 hrs.) Measurement to be made after keeping at room temperature for 4 to 48 hours	
Heat life Ref. JIS C5101-10 4.15	*Temperature : 85°C±2°C *Test Voltage : 5V *Time : 1000hrs (+48/-0 hrs.) Measurement to be made after keeping at room temperature for 4 to 48 hours	
Cold Resistance Ref. JIS C 0020	*Temperature : -40°C±2°C *Time : 1000hrs (+48/-0 hrs.) Measurement to be made after keeping at room temperature for 4 to 48 hours	

Approval sheet

SOLDERING CONDITION

Typical examples of soldering processes that provide reliable joints without any damage are given in Fig 2,

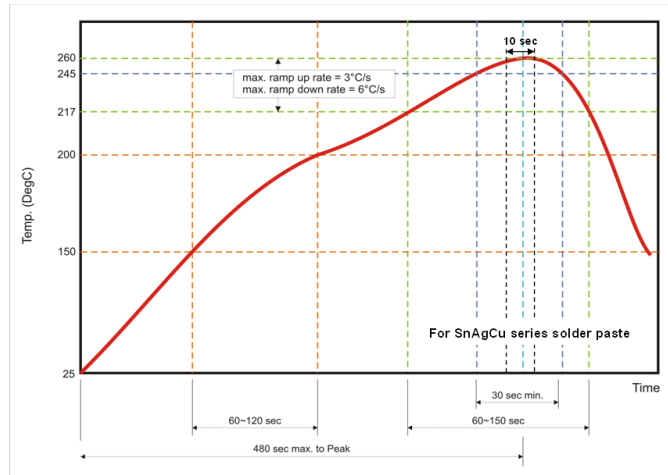

Fig 2. Infrared soldering profile

ORDERING CODE

RF	DSB	1210	13R	U	0	T
Walsin RF device	Product Code DSB: Differential Signal Balancer	Dimension code Per 2 digits of Length, Width. e.g. : 1210= Length 12 mm, Width 10 mm,	Delay time 130 ps	Application USB 3.1	Specification Design Code	Packing T : Reeled

Minimum Ordering Quantity: 2000 pcs per reel.

PACKAGING

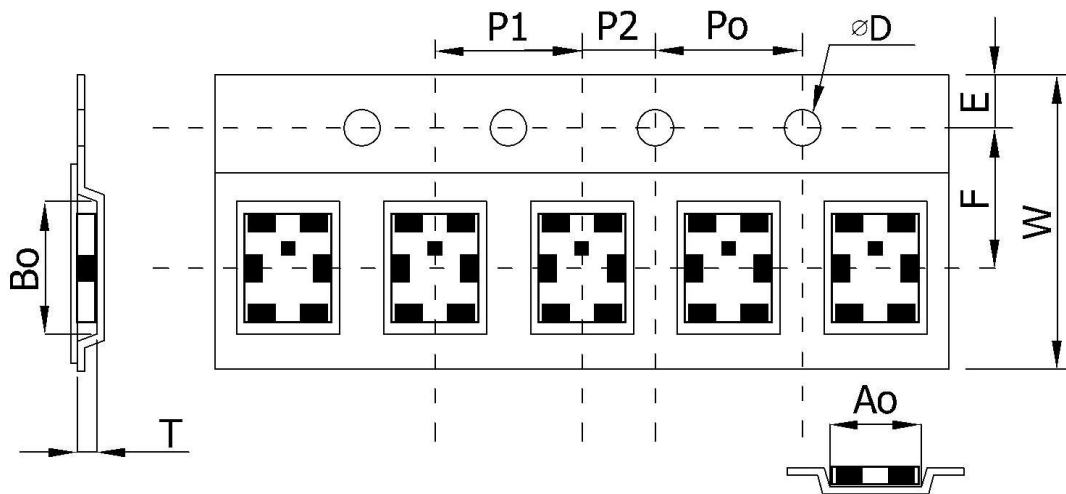

Plastic Tape specifications (unit :mm)

Index	A ₀	B ₀	ΦD	T	W
Dimension(mm)	1.20±0.10	1.40±0.10	1.50±0.10	0.90±0.10	8.00±0.10
Index	E	F	P ₀	P ₁	P ₂
Dimension(mm)	1.75±0.10	3.50±0.05	4.00±0.10	4.00±0.10	2.00±0.05

Reel dimensions

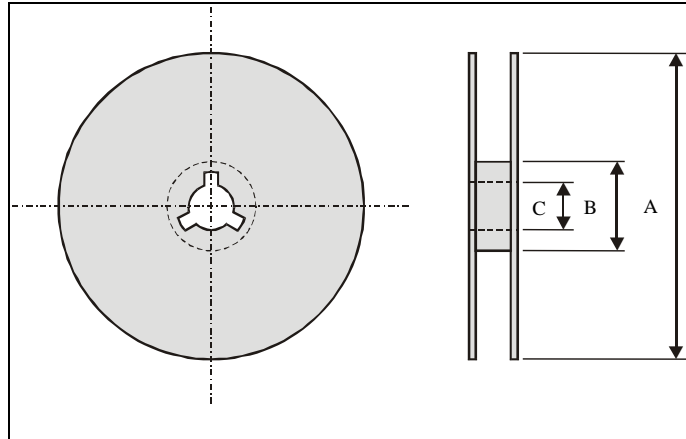

Index	A	B	C
Dimension (mm)	Φ178.0	Φ60.0	Φ13.0

Taping Quantity:2000 pieces per 7" reel

CAUTION OF HANDLING

Limitation of Applications

Please contact us before using our products for the applications listed below which require especially high reliability for the prevention of defects, which might directly cause damage to the third party's life, body or property.

- (1) Aircraft equipment
- (2) Aerospace equipment
- (3) Undersea equipment
- (4) Medical equipment
- (5) Disaster prevention / crime prevention equipment
- (6) Traffic signal equipment
- (7) Transportation equipment (vehicles, trains, ships, etc.)
- (8) Applications of similar complexity and /or reliability requirements to the applications listed in the above.

Storage condition

- (1) Products should be used in 6 months from the day of WALSIN outgoing inspection.
- (2) Storage environment condition.
 - Products should be storage in the warehouse on the following conditions.
 - Temperature : +5 to +40°C
 - Humidity : 30 to 70% relative humidity
 - Don't keep products in corrosive gases such as sulfur. Chlorine gas or acid or it may cause oxidization of electrode, resulting in poor solderability.
 - Products should be storage on the palette for the prevention of the influence from humidity, dust and son on.
 - Products should be storage in the warehouse without heat shock, vibration, direct sunlight and so on.
 - Products should be storage under the airtight packaged condition.
 -



Компания «ЭлектроПласт» предлагает заключение долгосрочных отношений при поставках импортных электронных компонентов на взаимовыгодных условиях!

Наши преимущества:

- Оперативные поставки широкого спектра электронных компонентов отечественного и импортного производства напрямую от производителей и с крупнейших мировых складов;
- Поставка более 17-ти миллионов наименований электронных компонентов;
- Поставка сложных, дефицитных, либо снятых с производства позиций;
- Оперативные сроки поставки под заказ (от 5 рабочих дней);
- Экспресс доставка в любую точку России;
- Техническая поддержка проекта, помощь в подборе аналогов, поставка прототипов;
- Система менеджмента качества сертифицирована по Международному стандарту ISO 9001;
- Лицензия ФСБ на осуществление работ с использованием сведений, составляющих государственную тайну;
- Поставка специализированных компонентов (Xilinx, Altera, Analog Devices, Intersil, Interpoint, Microsemi, Aeroflex, Peregrine, Syfer, Eurofarad, Texas Instrument, Miteq, Cobham, E2V, MA-COM, Hittite, Mini-Circuits, General Dynamics и др.);

Помимо этого, одним из направлений компании «ЭлектроПласт» является направление «Источники питания». Мы предлагаем Вам помощь Конструкторского отдела:

- Подбор оптимального решения, техническое обоснование при выборе компонента;
- Подбор аналогов;
- Консультации по применению компонента;
- Поставка образцов и прототипов;
- Техническая поддержка проекта;
- Защита от снятия компонента с производства.



Как с нами связаться

Телефон: 8 (812) 309 58 32 (многоканальный)

Факс: 8 (812) 320-02-42

Электронная почта: org@eplast1.ru

Адрес: 198099, г. Санкт-Петербург, ул. Калинина, дом 2, корпус 4, литера А.