

**2M-BIT
3V- QUAD SERIAL FLASH MEMORY WITH MULTI-I/O SPI****FEATURES****• Single Power Supply Operation**

- Low voltage range: 2.3 V - 3.6 V

• Memory Organization

- IS25LQ020A: 256K x 8 (2 Mbit)

• Cost Effective Sector/Block Architecture

- 2 Mb : Uniform 4KByte sectors / four uniform 64KByte blocks

• Serial Peripheral Interface (SPI) Compatible

- Supports single-, dual- or quad-output
- Supports SPI Modes 0 and 3
- Maximum 33 MHz clock rate for normal read
- Maximum 80 MHz clock rate for fast read
- Maximum 160 MHz clock rate equivalent Dual SPI
- Maximum 320 MHz clock rate equivalent Quad SPI

• Page Program (up to 256 Bytes) Operation

- Max 0.4 ms per page program

• Sector, Block or Chip Erase Operation

- Maximum 10 ms sector, block or chip erase

• Low Power Consumption

- Typical 10 mA active read current
- Typical 5 mA program/erase current

• Hardware Write Protection

- Protect and unprotect the device from write operation by Write Protect (WP#) Pin

• Software Write Protection

- The Block Protect (BP2, BP1, BP0) bits allow partial or entire memory to be configured as read-only

• High Product Endurance

- Guaranteed 100,000 program/erase cycles
- Minimum 20 years data retention

• Industrial Standard Pin-out and Package

- 8-pin 150mil SOIC
- 8-pin 150mil VVSOP
- 8-pin TSSOP
- Lead-free (Pb-free)

GENERAL DESCRIPTION

The IS25LQ020A are Serial Peripheral Interface (SPI) Flash memories, providing single-, dual or quad-output. The devices are designed to support a 33 MHz fclock rate in normal read mode, and 80 MHz in fast read, the fastest in the industry. The devices use a single low voltage power supply, ranging from 2.3 Volt to 3.6 Volt, to perform read, erase and program operations. The devices can be programmed in standard EPROM programmers.

The IS25LQ020A are accessed through a 4-wire SPI Interface consisting of Serial Data Input/Output (SIO), Serial Data Output (SO), Serial Clock (SCK), and Chip Enable (CE#) pins. The devices support page program mode, where 1 to 256 bytes data can be programmed into the memory in one program operation. These devices are divided into uniform 4 KByte sectors or 64 KByte Blocks in the IS25LQ020A.

The IS25LQ020A are manufactured on ISSI™'s advanced non-volatile technology. The devices are offered in 8-pin SOIC/VVSOP 150mil & 8-pin TSSOP.

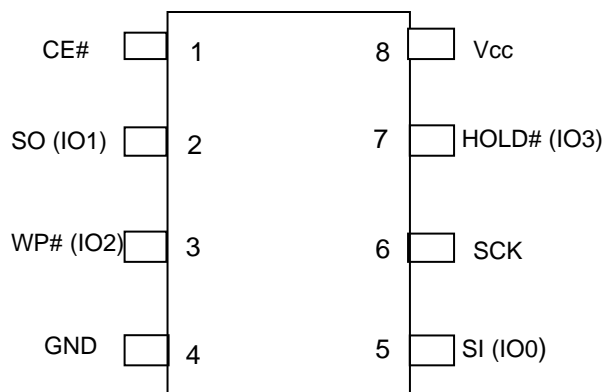
CONNECTION DIAGRAMS

8-Pin SOIC/VVSOP

8-Pin TSSOP
PIN DESCRIPTIONS

SYMBOL	TYPE	DESCRIPTION
CE#	INPUT	Chip Enable: CE# low activates the devices internal circuitries for device operation. CE# high deselected the devices and switches into standby mode to reduce the power consumption. When a device is not selected, data will not be accepted via the serial input pin (SI), and the serial output pin (SO) will remain in a high impedance state.
SCK	INPUT	Serial Data Clock
SI (IO0)	INPUT/OUTPUT	Serial Data Input/Output
SO (IO1)	OUTPUT	Serial Data Input/Output
GND		Ground
Vcc		Device Power Supply
WP# (IO2)	INPUT/OUTPUT	Write Protect/Serial Data Output: A hardware program/erase protection for all or part of a memory array. When the WP# pin is low, memory array write-protection depends on the setting of BP3, BP2, BP1 and BP0 bits in the Status Register. When the WP# is high, the devices are not write-protected. When the QE bit of is set "1", the /WP pin (Hardware Write Protect) function is not available since this pin is used for IO2
HOLD# (IO3)	INPUT	Hold/ Serial Data Output: Pause serial communication by the master device without resetting the serial sequence. When the QE bit of Status Register-2 is set for "1", the HOLD# pin function is not available since this pin is used for IO3.

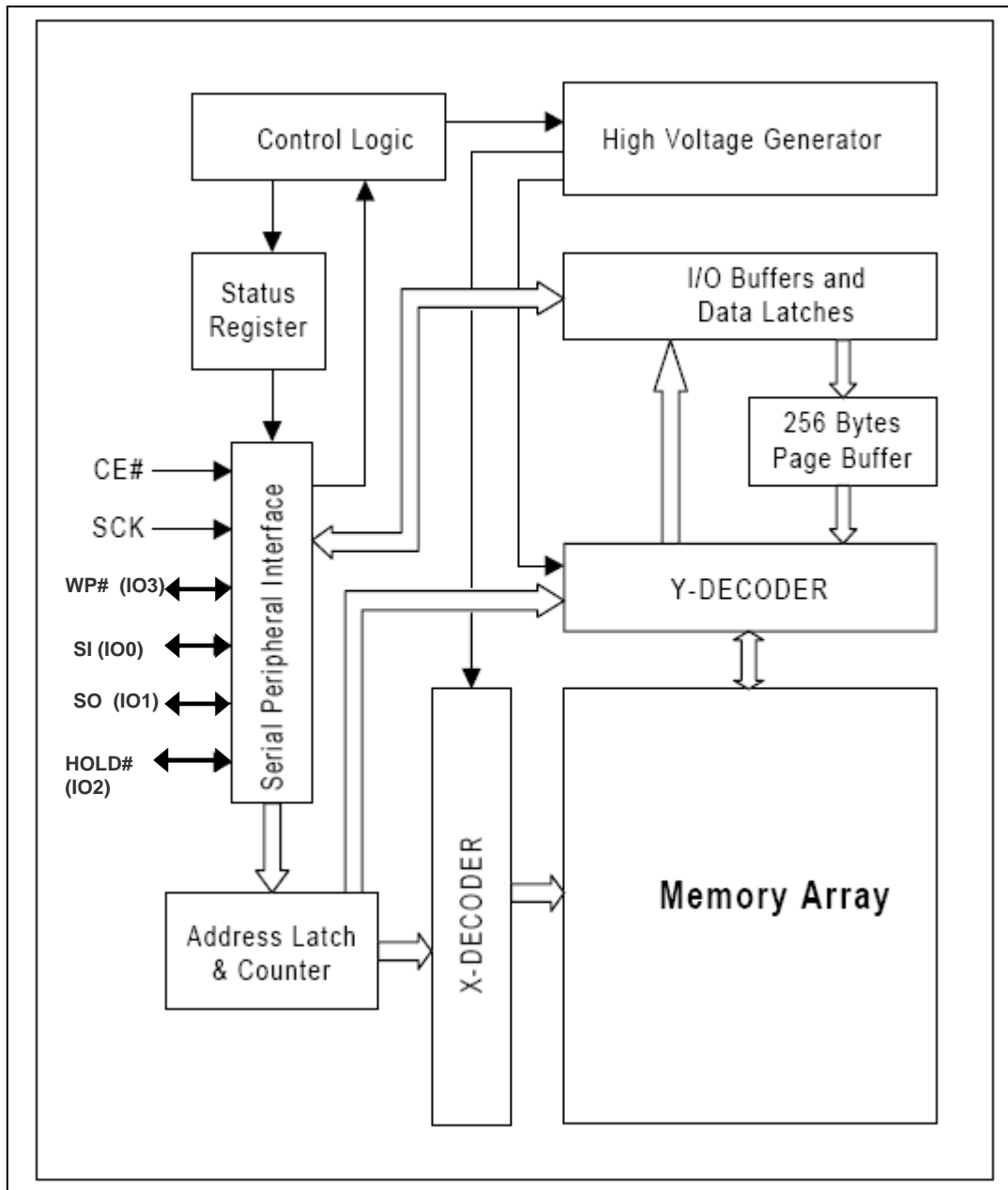
BLOCK DIAGRAM



SPI MODES DESCRIPTION

Multiple IS25LQ020A devices can be connected on the SPI serial bus and controlled by a SPI Master, i.e. microcontroller, as shown in Figure 1. The devices support either of two SPI modes:

- Mode 0 (0, 0)
- Mode 3 (1, 1)

The difference between these two modes is the clock polarity when the SPI master is in Stand-by mode: the serial clock remains at "0" (SCK = 0) for Mode 0 and the clock remains at "1" (SCK = 1) for Mode 3. Please refer to Figure 2. For both modes, the input data is latched on the rising edge of Serial Clock (SCK), and the output data is available from the falling edge of SCK.

Figure 1. Connection Diagram among SPI Master and SPI Slaves (Memory Devices)

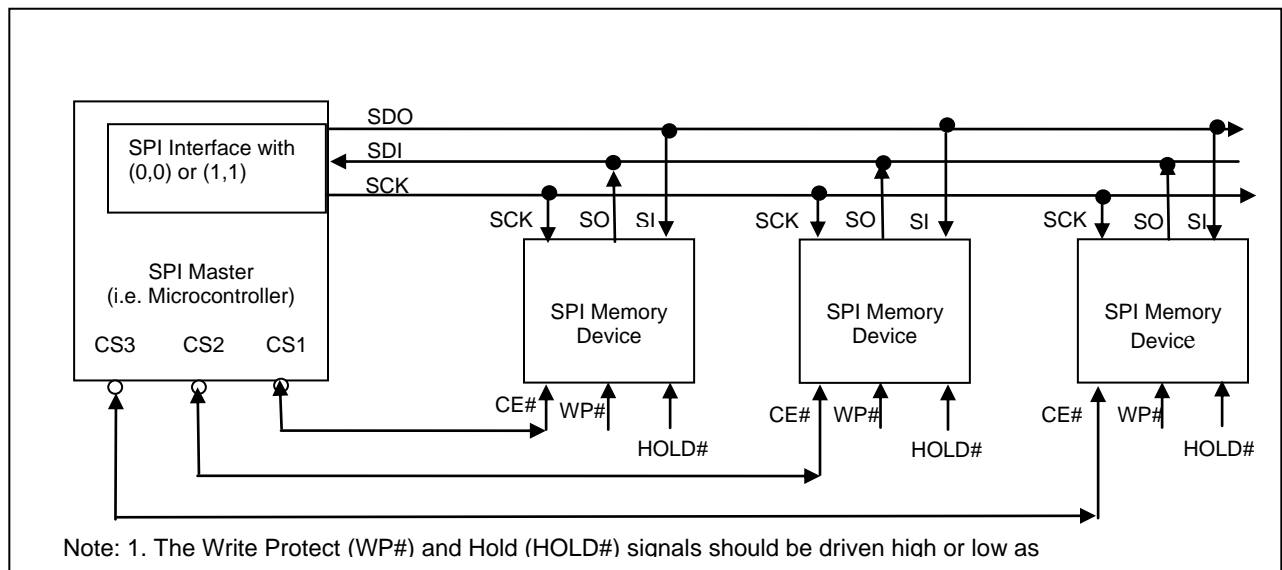
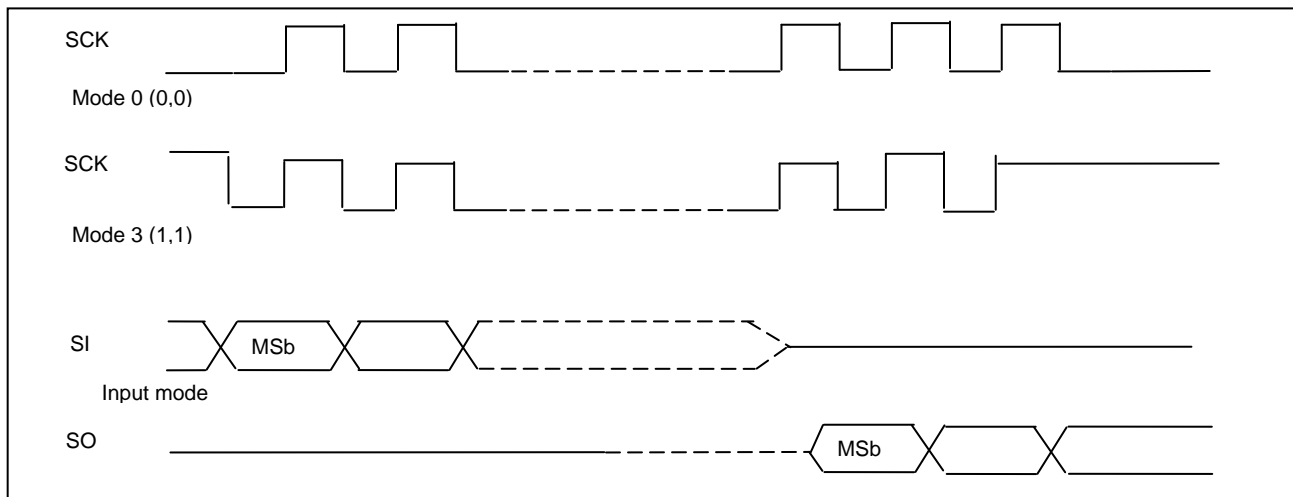

Figure 2. SPI Modes Supported





SYSTEM CONFIGURATION

The IS25LQ020A devices are designed to interface directly with the synchronous Serial Peripheral Interface (SPI) of the Motorola MC68HCxx series of microcontrollers or any SPI interface-equipped system controllers.

The IS25LQ020A memory array is divided into uniform 4 KByte sectors or uniform 64 KByte blocks (a block consists of sixteen adjacent sectors on the 2Mb).

Table 1 illustrates the memory map of the devices.

BLOCK/SECTOR ADDRESSES

Table 1. Block/Sector Addresses of IS25LQ020A

Memory Density	Block No.	Block Size (KBytes)	Sector No.	Sector Size (KBytes)	Address Range
2 Mbit	Block 0	64	Sector 0	4	000000h - 000FFFh
			Sector 1	4	001000h - 001FFFh
			:	:	:
			Sector 15	4	00F000h - 00FFFFh
	Block 1	64	Sector 16	4	010000h - 010FFFh
			Sector 17	4	011000h - 011FFFh
			:	:	:
			Sector 31	4	01F000h - 01FFFFh
	:	:	:	:	:
	Block 3	64	:	4	030000h - 03FFFFh

REGISTERS

STATUS REGISTER

Refer to Tables 5 and 6 for Status Register Format and Status Register Bit Definitions.

The BP0, BP1, BP2 and SRWD are non-volatile memory cells that can be written by a Write Status Register (WRSR) instruction. The default value of the BP2, BP1, BP0, and SRWD bits were set to “0” at factory. The Status Register can be read by the Read Status Register (RDSR). Refer to Table 10 for Instruction Set.

The function of Status Register bits are described as follows:

WIP bit: The Write In Progress (WIP) bit is read-only, and can be used to detect the progress or completion of a program or erase operation. When the WIP bit is “0”, the device is ready for a write status register, program or erase operation. When the WIP bit is “1”, the device is busy.

WEL bit: The Write Enable Latch (WEL) bit indicates the status of the internal write enable latch. When the WEL is “0”, the write enable latch is disabled, and all write operations, including write status register, page program, sector erase, block and chip erase operations are inhibited. When the WEL bit is “1”, write operations are allowed. The WEL bit is set by a Write Enable (WREN) instruction. Each write register, program and erase instruction must be preceded by a WREN instruction. The WEL bit can be reset by a Write Disable (WRDI) instruction. It will automatically be the reset after the completion of a write instruction.

BP2, BP1, BP0 bits: The Block Protection (BP2, BP1 and BP0) bits are used to define the portion of the memory area to be protected. Refer to Tables 7, 8 and 9 for the Block Write Protection bit settings. When a defined combination of BP2, BP1 and BP0 bits are set, the corresponding memory area is protected. Any program or erase operation to that area will be inhibited. Note: a Chip Erase (CHIP_ER) instruction is executed only if all the Block Protection Bits are set as “0”s.

SRWD bit: The Status Register Write Disable (SRWD) bits operates in conjunction with the Write Protection (WP#) signal to provide a Hardware Protection Mode. When the SRWD is set to “0”, the Status Register is not write-protected. When the SRWD is set to “1” and the WP# is pulled low (V_{IL}), the bits of Status Register (SRWD, BP2, BP1, BP0) become read-only, and a WRSR instruction will be ignored. If the SRWD is set to “1” and WP# is pulled high (V_{IH}), the Status Register can be changed by a WRSR instruction.

QE bit: The Quad Enable (QE) is a non-volatile bit in the status register that allows Quad operation. When the QE bit is set to “0”, the pin WP# and HOLD# are enable. When the QE bit is set to “1”, the pin IO2 and IO3 are enable.

WARNING: The QE bit should never be set to a 1 during standard SPI or Dual SPI operation if the WP# or HOLD# pins are tied directly to the power supply or ground.

Table 5. Status Register Format

	Bit 7	Bit 6	Bit 5	Bit 4	Bit 3	Bit 2	Bit 1	Bit 0
	SRWD1	QE	x	BP2	BP1	BP0	WEL	WIP
Default (flash bit)	0	0	0	0	0	0	0	0

* The default value of the BP2, BP1, BP0, and SRWD bits were set to “0” at factory.

**REGISTERS (CONTINUED)****Table 6. Status Register Bit Definition**

Bit	Name	Definition	Read- /Write	Non-Volatile bit
Bit 0	WIP	Write In Progress Bit: "0" indicates the device is ready "1" indicates a write cycle is in progress and the device is busy	R	No
Bit 1	WEL	Write Enable Latch: "0" indicates the device is not write enabled (default) "1" indicates the device is write enabled	R/W	No
Bit 2	BP0	Block Protection Bit: (See Tables 7, 8 and 9 for details) "0" indicates the specific blocks are not write-protected (default) "1" indicates the specific blocks are write-protected	R/W	Yes
Bit 3	BP1			
Bit 4	BP2			
Bit 5	X			
Bit 6	QE	Quad Enable bit: "0" indicates the Quad output function disable (default) "1" indicates the Quad output function enable	R/W	Yes
Bit 7	SRWD	Status Register Write Disable: (See Table 10 for details) "0" indicates the Status Register is not write-protected (default) "1" indicates the Status Register is write-protected	R/W	Yes

Table 7. Block Write Protect Bits for IS25LQ020A

Status Register Bits			IS25LQ020A- Protected Memory Area
BP2	BP1	BP0	2 Mbit
0	0	0	None
0	0	1	Upper quarter (block : 3): 030000h - 03FFFFh
0	1	0	Upper quarter (two blocks :2 and 3): 020000h - 03FFFFh
0	1	1	All Blocks

REGISTERS (CONTINUED) **PROTECTION MODE**

The IS25LQ020A have two types of write-protection mechanisms: hardware and software. These are used to prevent irrelevant operation in a possibly noisy environment and protect the data integrity.

HARDWARE WRITE-PROTECTION

The devices provide two hardware write-protection features:

- a. When inputting a program, erase or write status register instruction, the number of clock pulse is checked to determine whether it is a multiple of eight before the executing. Any incomplete instruction command sequence will be ignored.
- b. Write inhibit is 2.0V, all write sequence will be ignored when Vcc drop to 2.0V and lower.
- c. The Write Protection (WP#) pin provides a hardware write protection method for BP3, BP2, BP1, BP0 and SRWD in the Status Register. Refer to the STATUS REGISTER description.

SOFTWARE WRITE PROTECTION

DEVICE OPERATION

The IS25LQ020A utilize an 8-bit instruction register. Refer to Table 11 Instruction Set for details of the Instructions and Instruction Codes. All instructions, addresses, and data are shifted in with the most significant bit (MSB) first on Serial Data Input (SI). The input data on SI is latched on the rising edge of Serial Clock (SCK) after Chip Enable (CE#) is driven low (V_{IL}). Every instruction sequence starts with a one-byte

The IS25LQ020A also provides two software write protection features:

- a. Before the execution of any program, erase or write status register instruction, the Write Enable Latch (WEL) bit must be enabled by executing a Write Enable (WREN) instruction. If the WEL bit is not enabled first, the program, erase or write register instruction will be ignored.
- b. The Block Protection (BP2, BP1, BP0) bits allow part or the whole memory area to be write-protected.

Table 10. Hardware Write Protection on Status Register

SRWD	WP#	Status Register
0	Low	Writable
1	Low	Protected
0	High	Writable
1	High	Writable

instruction code and is followed by address bytes, data bytes, or both address bytes and data bytes, depending on the type of instruction. CE# must be driven high (V_{IH}) after the last bit of the instruction sequence has been shifted in.

The timing for each instruction is illustrated in the following operational descriptions.



Table 11. Instruction Set

Instruction Name	Hex Code	Operation	Command Cycle	Maximum Frequency
RDID/RDES	ABh	Read Product ID and Release from Deep Power Down	4 Bytes	80 MHz
JEDEC ID READ	9Fh	Read Manufacturer and Product ID by JEDEC ID Command	1 Byte	80 MHz
RDMDID	90h	Read Manufacturer and Device ID	4 Bytes	80 MHz
WREN	06h	Write Enable	1 Byte	80 MHz
WRDI	04h	Write Disable	1 Byte	80 MHz
RDSR	05h	Read Status Register	1 Byte	80 MHz
WRSR	01h	Write Status Register	2 Bytes	80 MHz
READ	03h	Read Data Bytes from Memory at Normal Read Mode	4 Bytes	33 MHz
FAST_READ	0Bh	Read Data Bytes from Memory at Fast Read Mode	5 Bytes	80 MHz
FRDO	3Bh	Fast Read Dual Output	5 Bytes	80 MHz
FRDIO	BBh	Fast Read Dual I/O	3 Bytes	80MHz
FRQO	6Bh	Fast Read Quad Output	5 Bytes	80 MHz
FRQIO	EBh	Fast Read Quad I/O	2 Bytes	80MHz
MR	FFh	Mode Reset	2 Byte	80MHz
PAGE_PROG	02h	Page Program Data Bytes Into Memory	4 Bytes + 256B	80 MHz
SECTOR_ER	D7h/ 20h	Sector Erase	4 Bytes	80 MHz
BLOCK_ER	D8h	Block Erase	4 Bytes	80 MHz
CHIP_ER	C7h/ 60h	Chip Erase	1 Byte	80 MHz
Quad page program	32h	Page Program Data Bytes Into Memory with Quad interface	4 Bytes + 256B	
Program information Raw	B1h	Program 65 bytes of Security area	4 Bytes	80 MHz
Read information Raw	4Bh	Read 65 bytes of Security area	4 Bytes	33 MHz

HOLD OPERATION

HOLD# is used in conjunction with CE# to select the IS25LQ020A. When the devices are selected and a serial sequence is underway, HOLD# can be used to pause the serial communication with the master device without resetting the serial sequence.

To pause, HOLD# is brought low while the SCK signal is low. To resume serial communication, HOLD# is brought high while the SCK signal is low (SCK may still toggle during HOLD). Inputs to SI will be ignored while SO is in the high impedance state.

DEVICE OPERATION (CONTINUED)
RDID (READ PRODUCT IDENTIFICATION) / RDES (RELEASE FROM DEEP POWER DOWN) COMMAND

The Read Product Identification (RDID) instruction is for reading out an 8-bit Electronic Signature whose values are shown in Table 12: Product Identification. The output of RDID is not the same as the newer JEDEC ID instruction. RDID is not recommended for new designs. For new designs please use the JEDEC ID instruction.

The RDID/RDES instruction code is followed by three dummy bytes, each bit being latched-in on SI during the rising edge of SCK. Then the Device ID is shifted out on SO with the MSB first, each bit been shifted out during the falling edge of SCK. The RDID/RDES instruction is ended by CE# goes high. The Device ID outputs repeatedly if clock cycles continue on SCK while CE# is held low.

To release the device from the RDID/RDES instruction, drive CE# high as shown in figure 3.

Before the device can resume normal operations and other instructions are accepted, the time t_{RES1} must first pass. The CE# pin must remain high during the t_{RES1} time duration. If the RDID/RDES instruction is issued while an Erase, Program or Write cycle is in process (when BUSY equals 1) the instruction is ignored and will not have any effects on the current cycle.

Table 12. Product Identification

Product Identification		Data
Manufacturer ID:	First (ID1)	9Dh
	Second (ID2)	7Fh
Device ID:	ID1	ID2
IS25LQ020A	11h	42h

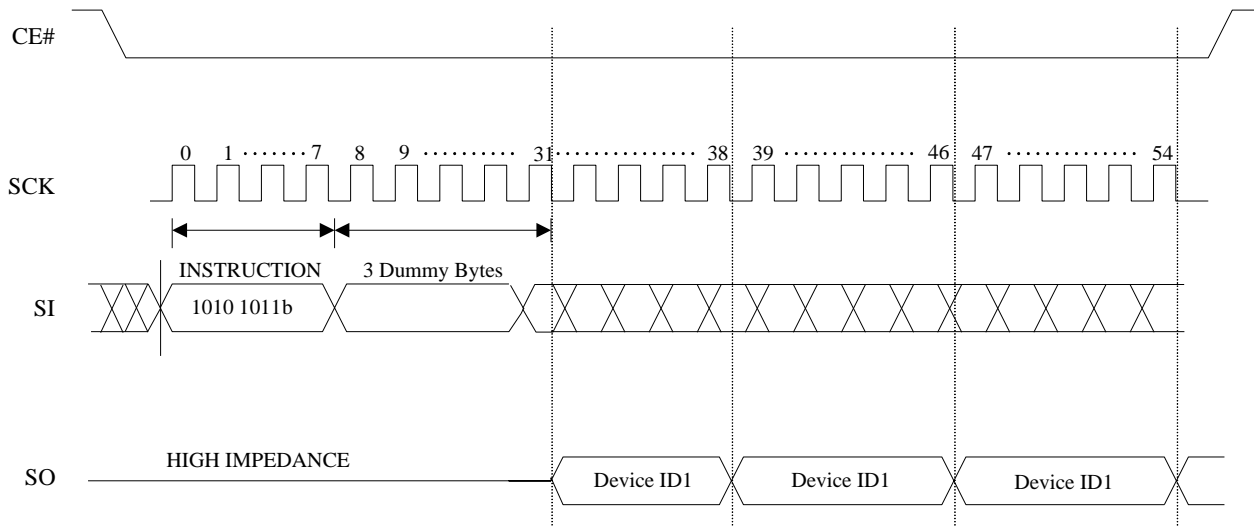
Figure 3. Read Product Identification Sequence

DEVICE OPERATION (CONTINUED)
JEDEC ID READ COMMAND (READ PRODUCT IDENTIFICATION BY JEDEC ID) OPERATION

The JEDEC ID READ instruction allows the user to read the manufacturer and product ID of devices. Refer to Table 12 Product Identification for ISSI Manufacturer ID and Device ID. After the JEDEC ID READ command is input, the second Manufacturer ID (7Fh) is shifted out on SO with the MSB first, followed by the first

Manufacturer ID (9Dh) and the Device ID (42h, in the case of the IS25LQ020A), each bit shifted out during the falling edge of SCK. If CE# stays low after the last bit of the Device ID is shifted out, the Manufacturer ID and Device ID will loop until CE# is pulled high.

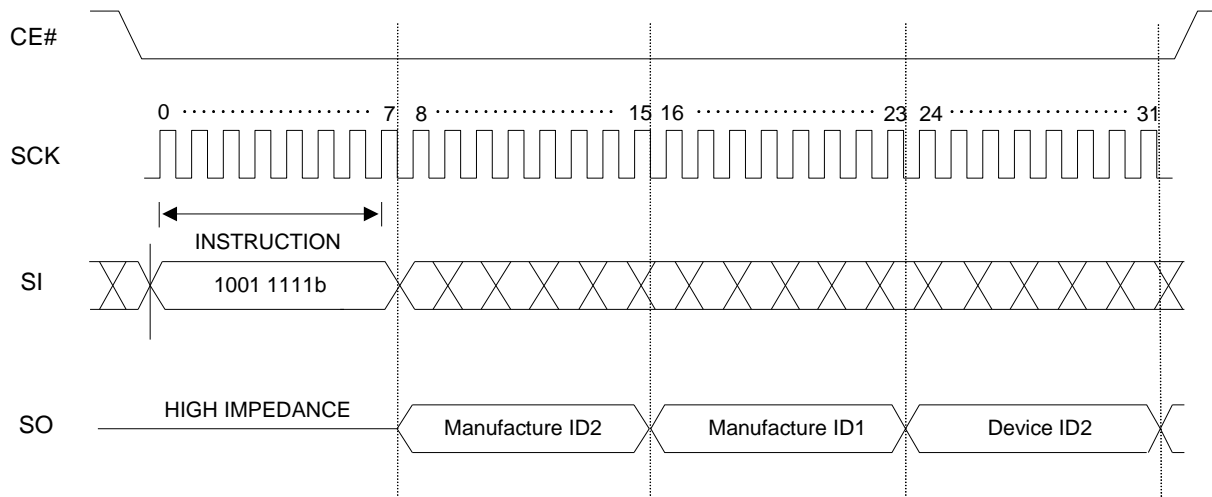
Figure 4. Read Product Identification by JEDEC ID READ Sequence

DEVICE OPERATION (CONTINUED)
RDMDID COMMAND (READ DEVICE MANUFACTURER AND DEVICE ID) OPERATION

The RDMDID instruction allows the user to read the manufacturer and product ID of the devices. Refer to Table 12 Product Identification for ISSI™ manufacturer ID and device ID. The RDMDID instruction code is followed by two dummy bytes and one byte address (A7~A0), each bit being latched-in on SI during the rising edge of SCK. If one byte address is initially set to A0 = 0, then the first manufacturer ID (9Dh) is shifted out on SO with the MSB first, the device ID1 and the

second manufacturer ID (7Fh), each bit shifted out during the falling edge of SCK. If one byte address is initially set to A0 = 1, then device ID1 will be read first, followed by the first manufacture ID (9Dh), and then second manufacture ID (7Fh). The manufacture and device ID1 can be read continuously, alternating from one to the others. The instruction is completed by driving CE# high.

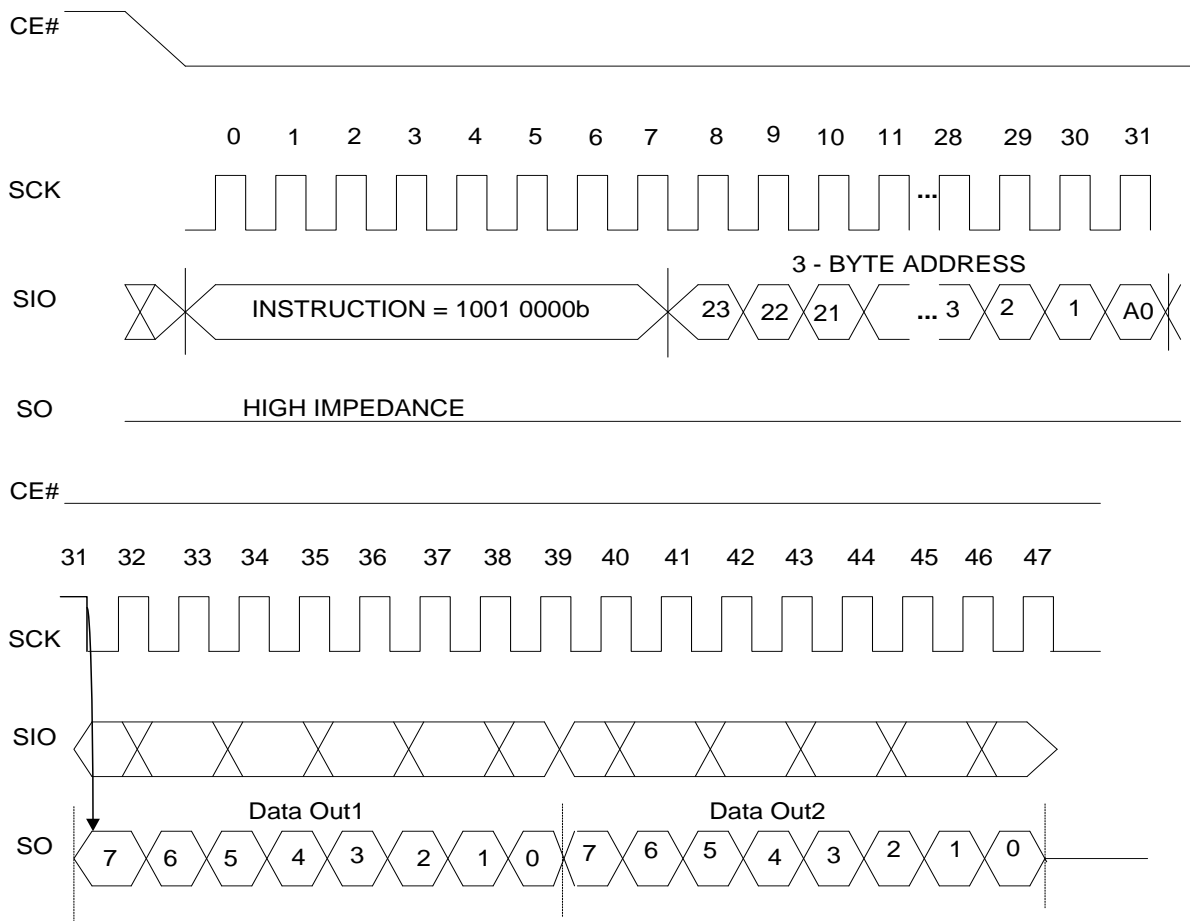
Figure 5. Read Product Identification by RDMDID READ Sequence

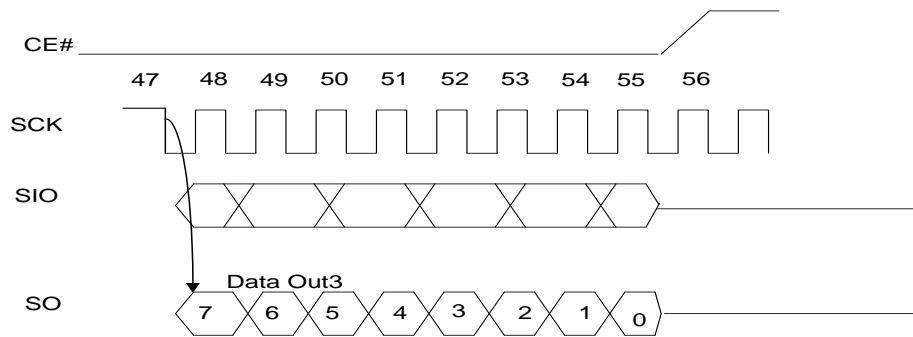

Note :

- (1) ADDRESS A0 = 0, will output Manufacture ID1 first -> Device ID1-> Manufacturing ID2
ex: 9Dh,11h,7Fh and repeat until device is de-selected
- (2) ADDRESS A0 = 1, will output Device ID1 first -> Manufacturing ID1-> Manufacturing ID2
ex: 11h,9Dh,7Fh and repeat until device is de-selected

DEVICE OPERATION (CONTINUED)

WRITE ENABLE OPERATION

The Write Enable (WREN) instruction is used to set the Write Enable Latch (WEL) bit. The WEL bit of the IS25Q020A is reset to the write –protected state after power-up. The WEL bit must be write enabled before any write operation, including sector, block erase, chip

erase, page program, and write status register. The WEL bit will be reset to the write-protect state automatically upon completion of a write operation. The WREN instruction is required before any above operation is executed.

Figure 6. Write Enable Sequence

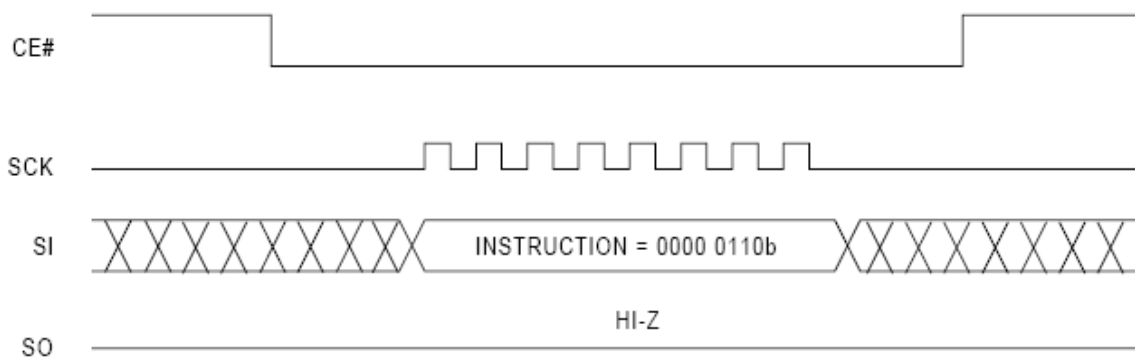

WRDI COMMAND (WRITE DISABLE) OPERATION

The Write Disable (WRDI) instruction resets the WEL bit and disables all write instructions. The WRDI

instruction is not required after the execution of a write instruction, since the WEL bit is automatically reset.

Figure 7. Write Disable Sequence

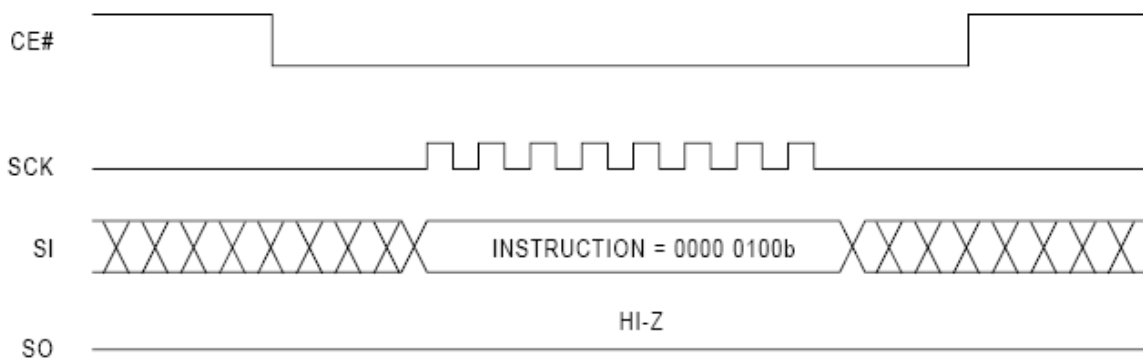

DEVICE OPERATION (CONTINUED)
RDSR COMMAND (READ STATUS REGISTER) OPERATION

The Read Status Register (RDSR) instruction provides access to the Status Register. During the execution of a program, erase or write status register operation, all other instructions will be ignored except the RDSR

instruction, which can be used to check the progress or completion of an operation by reading the WIP bit of Status Register.

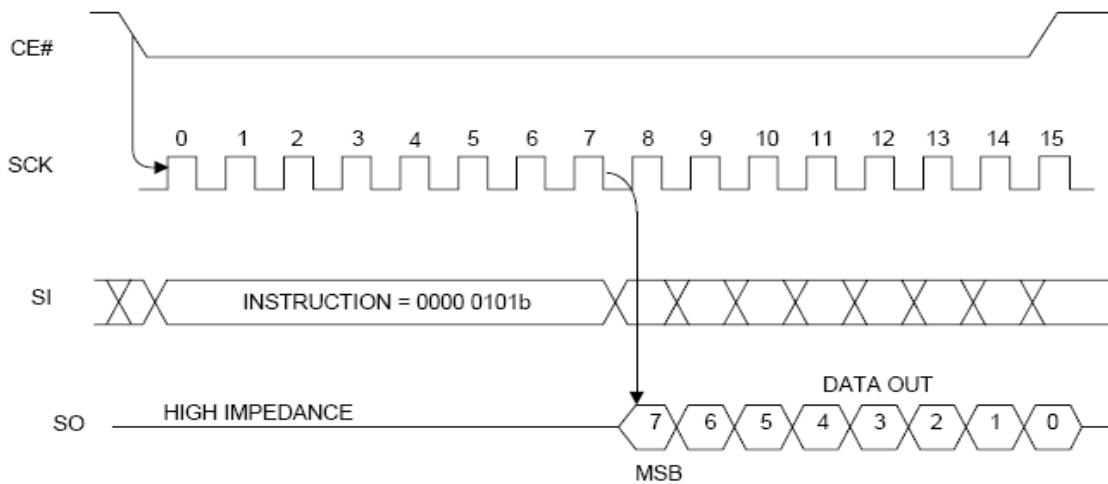
Figure 8. Read Status Register Sequence

WRSR COMMAND (WRITE STATUS REGISTER) OPERATION

The Write Status Register (WRSR) instruction allows the user to enable or disable the block protection and status register write protection features by writing "0"s

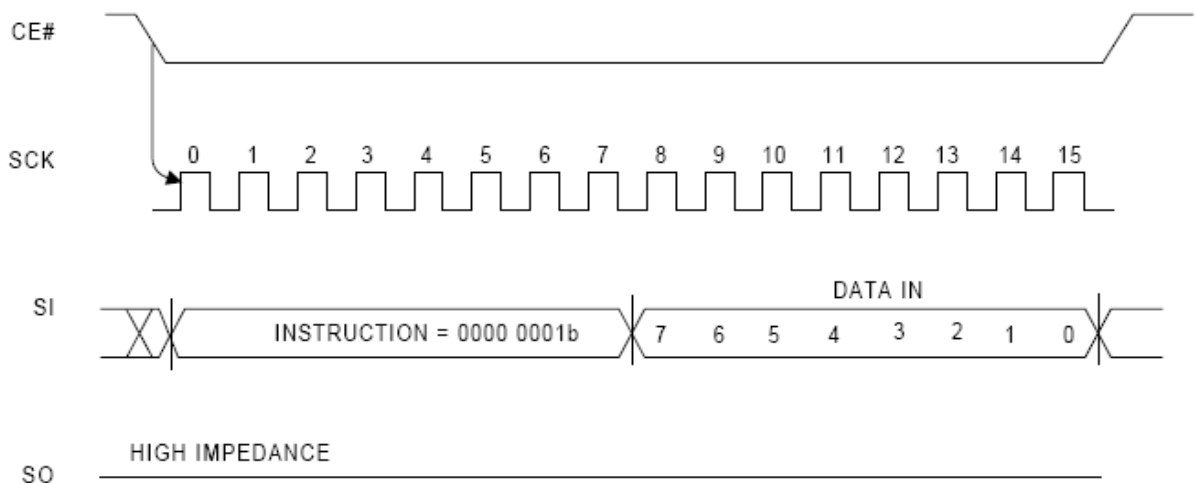
or "1"s into the non-volatile BP2, BP1, BP0 and SRWD bits.

Figure 9. Write Status Register Sequence

DEVICE OPERATION (CONTINUED)
READ COMMAND (READ DATA) OPERATION

The Read Data (READ) instruction is used to read memory data of a IS25LQ020A under normal mode running up to 33 MHz.

The READ instruction code is transmitted via the SI line, followed by three address bytes (A23 - A0) of the first memory location to be read. A total of 24 address bits are shifted in, but only A_{MS} (most significant address) - A0 are decoded. The remaining bits (A23 - A_{MS}) are ignored. The first byte addressed can be at any memory location. Upon completion, any data on the SI will be ignored. Refer to Table 13 for the related Address Key.

The first byte data (D7 - D0) addressed is then shifted

out on the SO line, MSB first. A single byte of data, or up to the whole memory array, can be read out in one READ instruction. The address is automatically incremented after each byte of data is shifted out. The read operation can be terminated at any time by driving CE# high (V_{IH}) after the data comes out. When the highest address of the devices is reached, the address counter will roll over to the 000000h address, allowing the entire memory to be read in one continuous READ instruction.

If a Read Data instruction is issued while an Erase, Program or Write cycle is in process (BUSY=1) the instruction is ignored and will not have any effects on the current cycle

Table 13. Address Key

Address	IS25LQ020A
$A_N (A_{MS} - A_0)$	A17 - A0
Don't Care Bits	A23 - A18

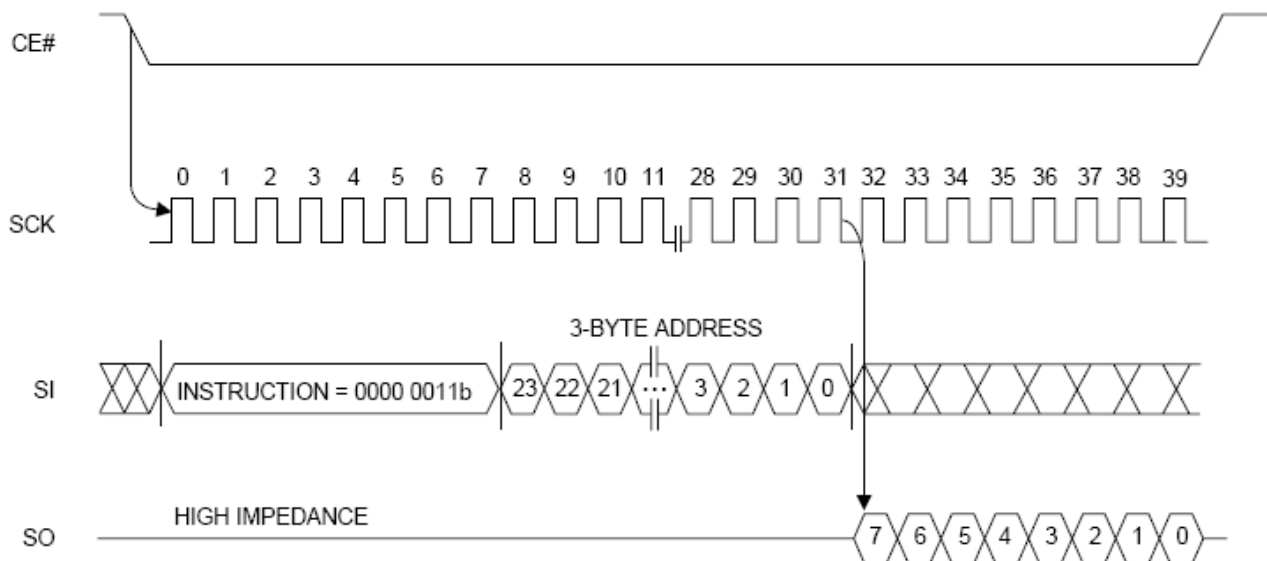
Figure 12. Read Data Sequence

DEVICE OPERATION (CONTINUED)
FAST_READ COMMAND (FAST READ DATA) OPERATION

The FAST_READ instruction is used to read memory data at up to a 80 MHz clock.

The FAST_READ instruction code is followed by three address bytes (A23 - A0) and a dummy byte (8 clocks), transmitted via the SI line, with each bit latched-in during the rising edge of SCK. Then the first data byte addressed is shifted out on the SO line, with each bit shifted out at a maximum frequency f_{CT} , during the falling edge of SCK.

The first byte addressed can be at any memory location. The address is automatically incremented after each byte of data is shifted out. When the highest address is reached, the address counter will roll over to the 000000h address, allowing the entire memory to be read with a single FAST_READ instruction. The FAST_READ instruction is terminated by driving CE# high (V_{IH}). If a Fast Read Data instruction is issued while an Erase, Program or Write cycle is in process (BUSY=1) the instruction is ignored and will not have any effects on the current cycle

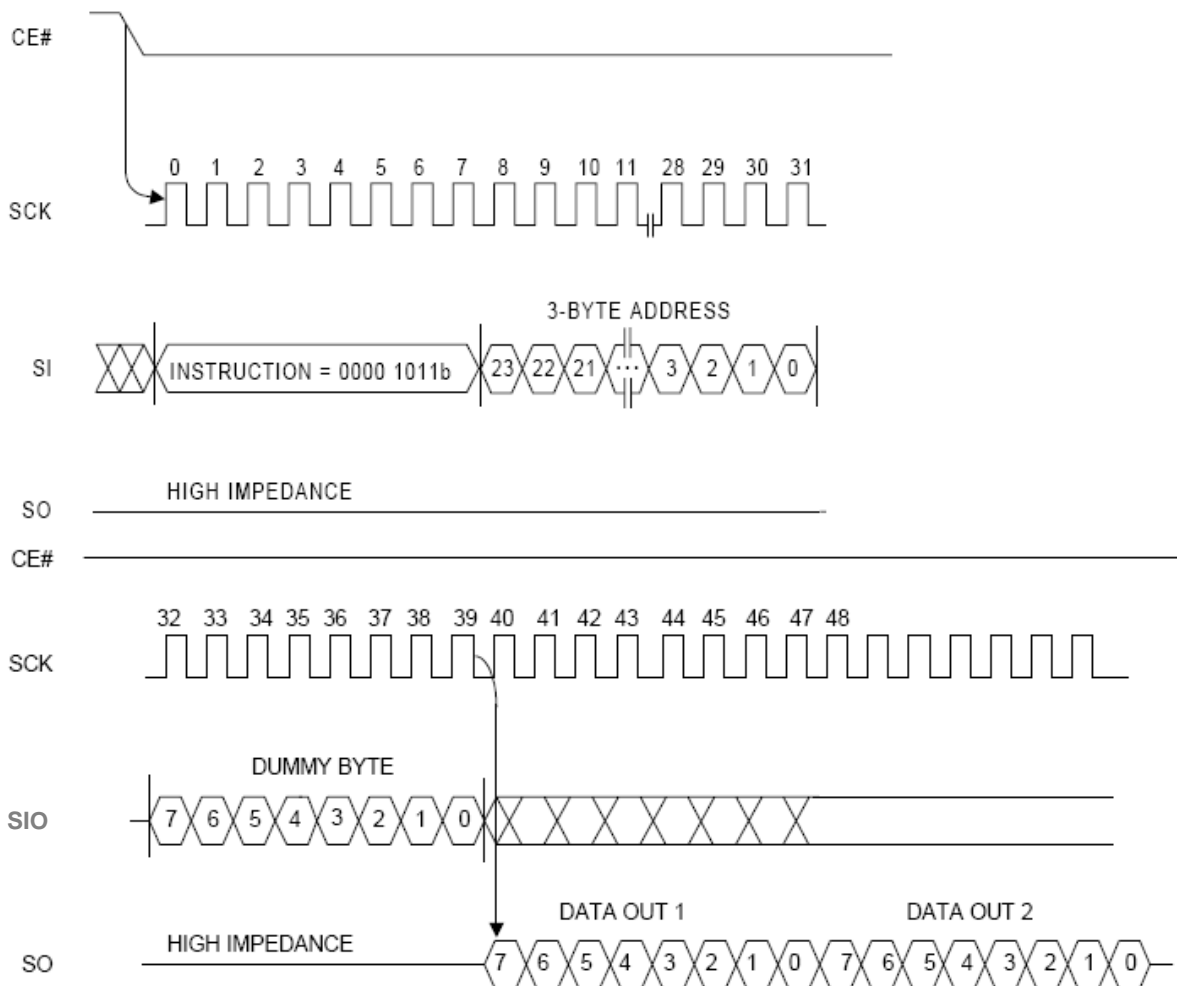
Figure 13. Fast Read Data Sequence

DEVICE OPERATION (CONTINUED)
FRDO COMMAND (FAST READ DUAL OUTPUT) OPERATION

The FRDO instruction is used to read memory data on two output pins each at up to a 80 MHz clock.

The FRDO instruction code is followed by three address bytes (A23 - A0) and a dummy byte (8 clocks), transmitted via the SI line, with each bit latched-in during the rising edge of SCK. Then the first data byte addressed is shifted out on the SO and SIO lines, with each pair of bits shifted out at a maximum frequency f_{CT} , during the falling edge of SCK. The first bit (MSb) is output on SO, while simultaneously the second bit is output on SIO.

The first byte addressed can be at any memory location. The address is automatically incremented after each byte of data is shifted out. When the highest address is reached, the address counter will roll over to the 000000h address, allowing the entire memory to be read with a single FRDO instruction. FRDO instruction is terminated by driving CE# high (V_{IH}). If a FRDO instruction is issued while an Erase, Program or Write cycle is in process (BUSY=1) the instruction is ignored and will not have any effects on the current cycle

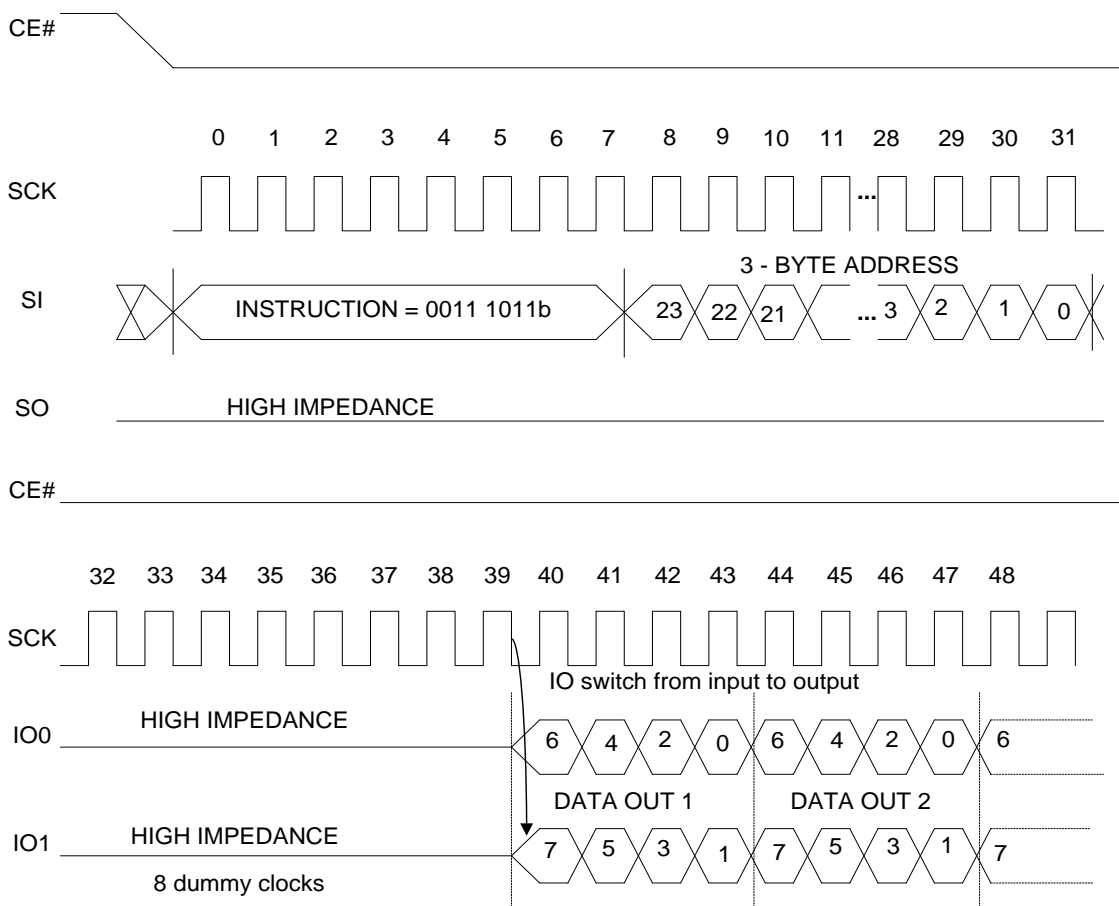
Figure 14. Fast Read Dual-Output Sequence

DEVICE OPERATION (CONTINUED)

FRDIO COMMAND (FAST READ DUAL I/O) OPERATION

The FRDIO instruction is similar to the FRDO instruction, but allows the address bits to be input two bits at a time. This may allow for code to be executed directly from the SPI in some applications.

The FRDIO instruction code is followed by three address bytes (A23 - A0) and a mode byte, transmitted via the IO0 and IO1 lines, with each pair of bits latched-in during the rising edge of SCK. The address MSb is input on IO1, the next bit on IO0, and continues to shift in alternating on the two lines. The mode byte contains the value Ax, where x is a "don't care" value. Then the first data byte addressed is shifted out on the IO1 and IO0 lines, with each pair of bits shifted out at a maximum frequency f_{CT} , during the falling edge of SCK. The MSb is output on IO1, while simultaneously the second bit is output on IO0. Figure 15 illustrates the timing sequence.

The first byte addressed can be at any memory location. The address is automatically incremented after each byte of data is shifted out. When the highest address is reached, the address counter will roll over to the 000000h address, allowing the entire memory to be read with a single FRDIO instruction. FRDIO instruction is terminated by driving CE# high (V_{IH}).

The device expects the next operation will be another FRDIO. It remains in this mode until it receives a Mode Reset (FFh) command. In subsequent FRDIO execution, the command code is not input, saving timing cycles as described in Figure 16. If a FRDIO instruction is issued while an Erase, Program or Write cycle is in process (BUSY=1) the instruction is ignored and will not have any effects on the current cycle

Figure 15. Fast Read Dual I/O Sequence (with command decode cycles)

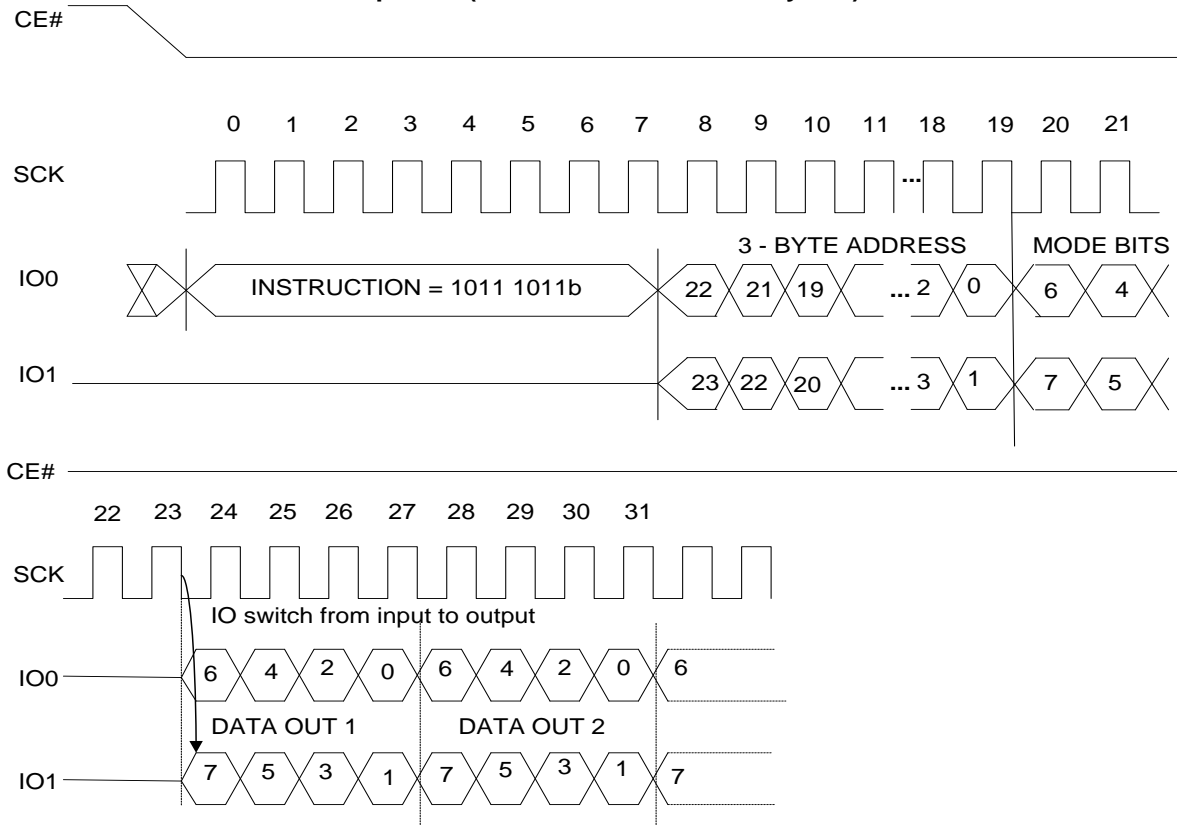

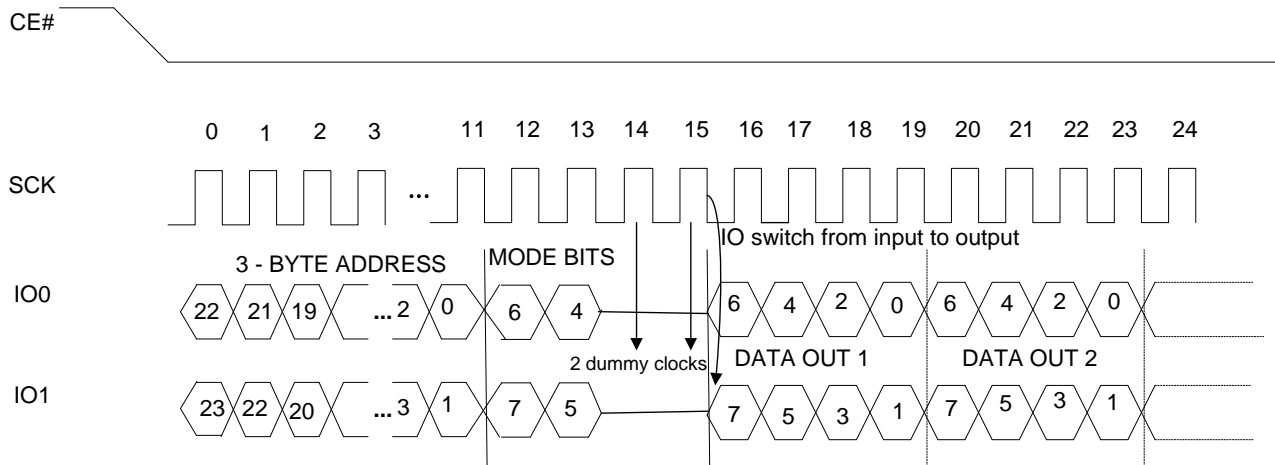
DEVICE OPERATION (CONTINUED)
Figure 16. Fast Read Dual I/O Sequence (without command decode cycles)

FRQO COMMAND (FAST READ QUAD OUTPUT) OPERATION

The FRQO instruction is used to read memory data on four output pins each at up to a 80 MHz clock.

The FRQO instruction code is followed by three address bytes (A23 - A0) and a dummy byte (8 clocks), transmitted via the SI line, with each bit latched-in during the rising edge of SCK. Then the first data byte addressed is shifted out on the IO3, IO2, IO1 and IO0 lines, with each group of four bits shifted out at a maximum frequency f_{CT} , during the falling edge of SCK. The first bit (MSb) is output on IO3, while

simultaneously the second bit is output on IO2, the third bit is output on IO1, etc.

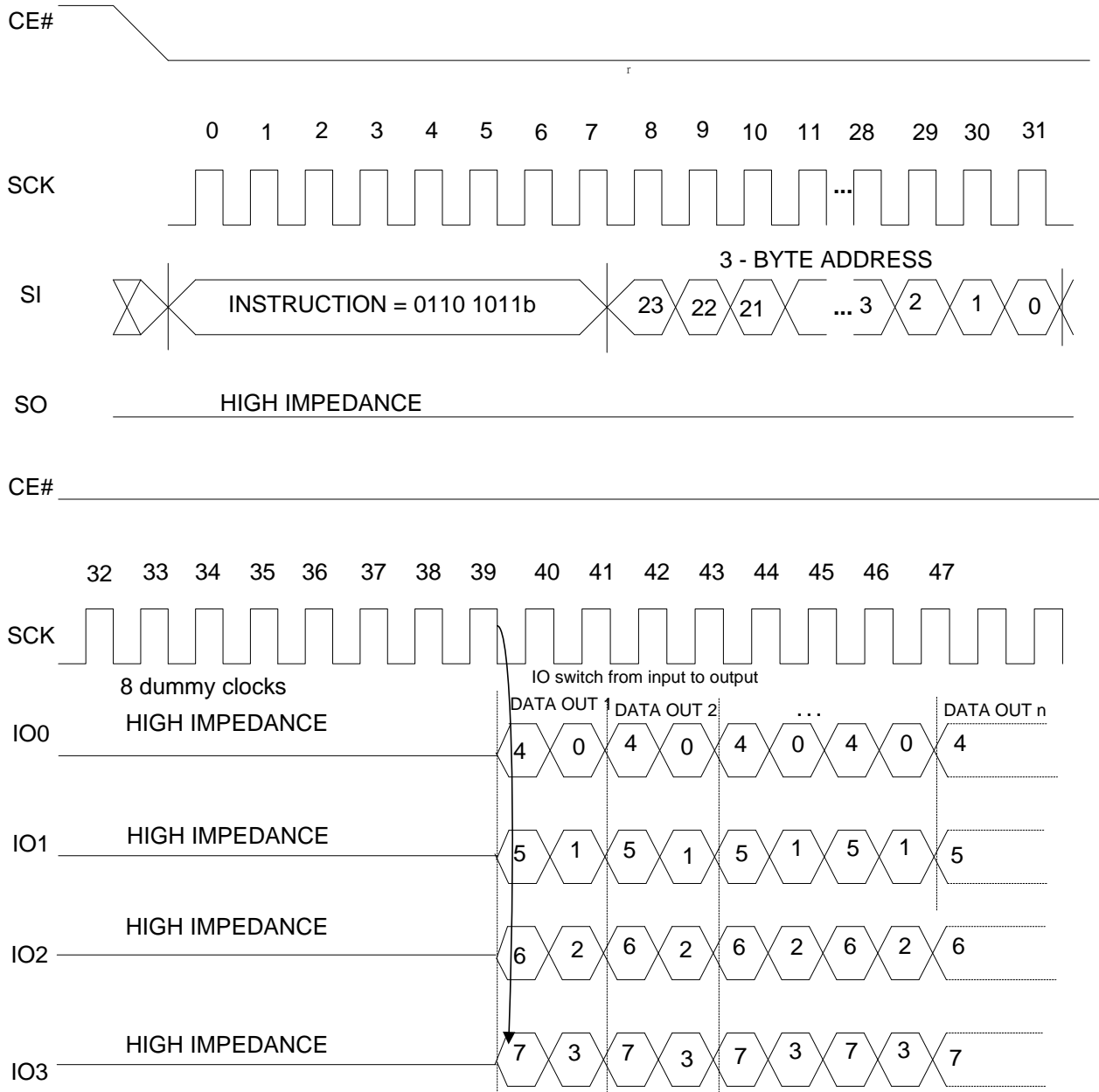
The first byte addressed can be at any memory location. The address is automatically incremented after each byte of data is shifted out. When the highest address is reached, the address counter will roll over to the 000000h address, allowing the entire memory to be read with a single FRQO instruction. FRQO instruction is terminated by driving CE# high (V_{IH}). If a FRQO instruction is issued while an Erase, Program or Write cycle is in process (BUSY=1) the instruction is ignored and will not have any effects on the current cycle

DEVICE OPERATION (CONTINUED)
Figure 17. Fast Read Quad-Output Sequence

DEVICE OPERATION (CONTINUED)

FRQIO COMMAND (FAST READ QUAD I/O) OPERATION

The FRQIO instruction is similar to the FRQO instruction, but allows the address bits to be input four bits at a time. This may allow for code to be executed directly from the SPI in some applications.

The FRQIO instruction code is followed by three address bytes (A23 - A0) and a mode byte, transmitted via the IO3, IO2, IO0 and IO1 lines, with each group of four bits latched-in during the rising edge of SCK. The address MSb is input on IO3, the next bit on IO2, the next bit on IO1, the next bit on IO0, and continue to shift in alternating on the four. The mode byte contains the value Ax, where x is a "don't care" value. Then the first data byte addressed is shifted out on the IO3, IO2, IO1 and IO0 lines, with each group of four bits shifted out at a maximum frequency f_{CT} , during the falling edge of SCK. The first bit (MSb) is output on IO3, while simultaneously the second bit is output on IO2, the

third bit is output on IO1, etc. Figure 18 illustrates the timing sequence.

The first byte addressed can be at any memory location. The address is automatically incremented after each byte of data is shifted out. When the highest address is reached, the address counter will roll over to the 000000h address, allowing the entire memory to be read with a single FRQIO instruction. FRQIO instruction is terminated by driving CE# high (V_{IH}).

The device expects the next operation will be another FRQIO. It remains in this mode until it receives a Mode Reset (FFh) command. In subsequent FRDIO execution, the command code is not input, saving cycles as described in Figure 19. If a FRQIO instruction is issued while an Erase, Program or Write cycle is in process (BUSY=1) the instruction is ignored and will not have any effects on the current cycle

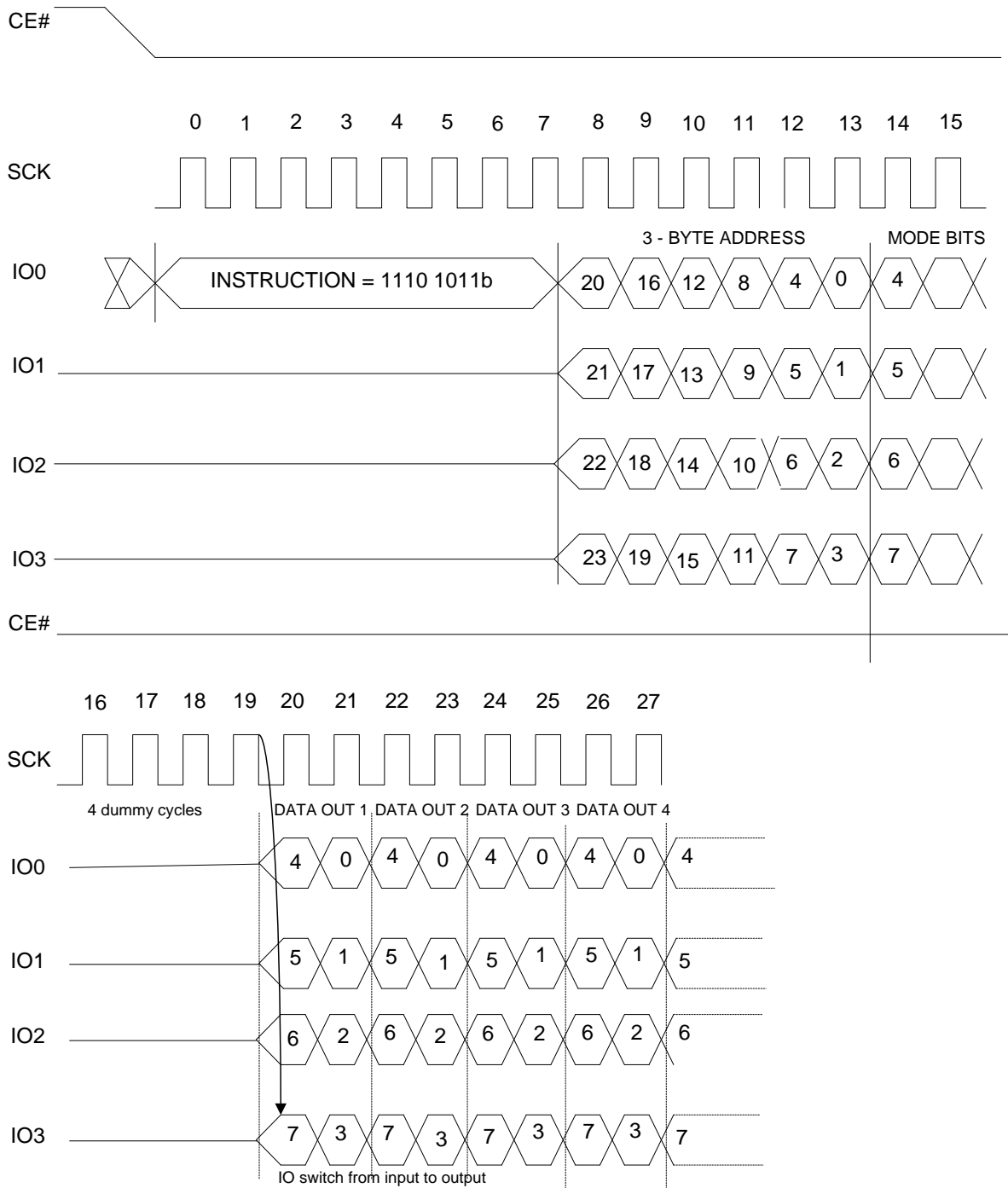
Figure 18. Fast Read Quad I/O Sequence (with command decode cycles)

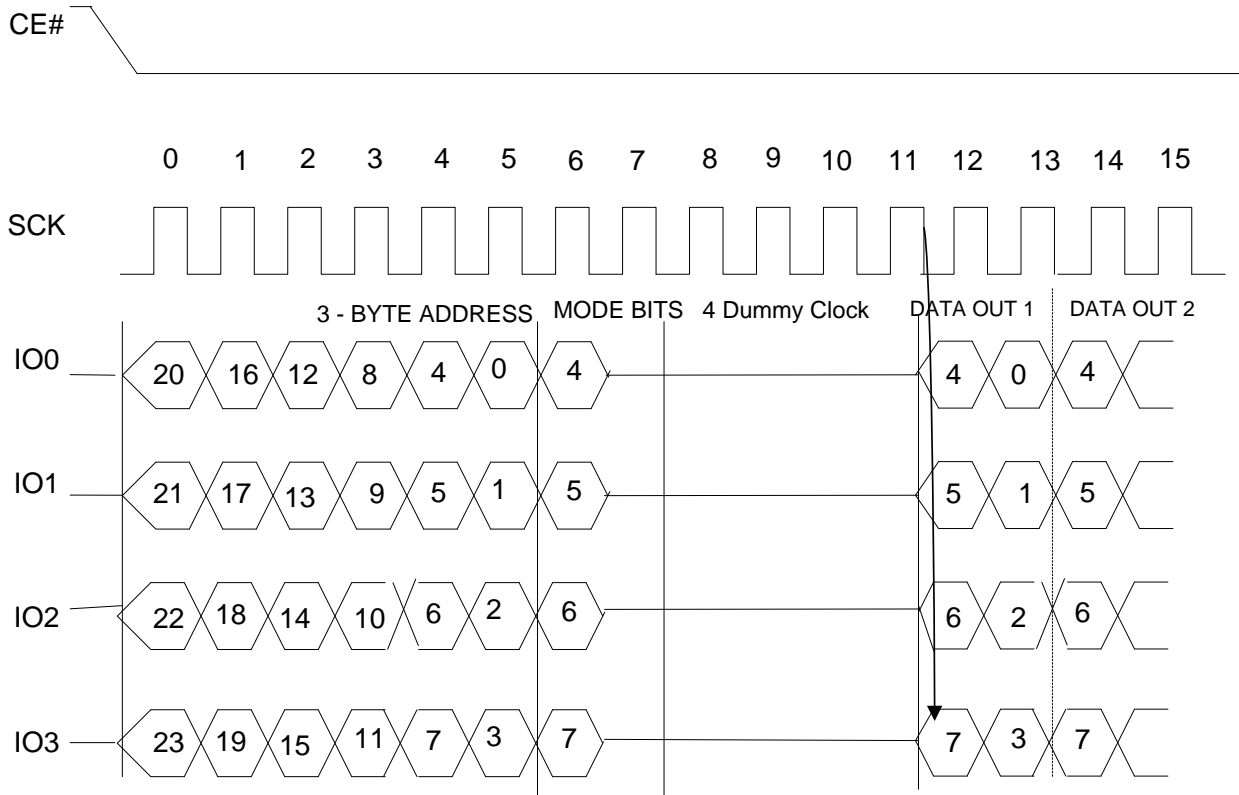
DEVICE OPERATION (CONTINUED)
Figure 19. Fast Read Quad I/O Sequence (without command decode cycles)

MR COMMAND (MODE RESET) OPERATION

The Mode Reset command is used to conclude subsequent FRDIO and FRQIO operations. It resets the Mode bits to a value that is not Ax. It should be executed after an FRDIO or FRQIO operation, and is recommended also as the first

command after a system reset. The timing sequence is different depending whether the MR command is used after an FRDIO or FRQIO, as shown in Figure 20.

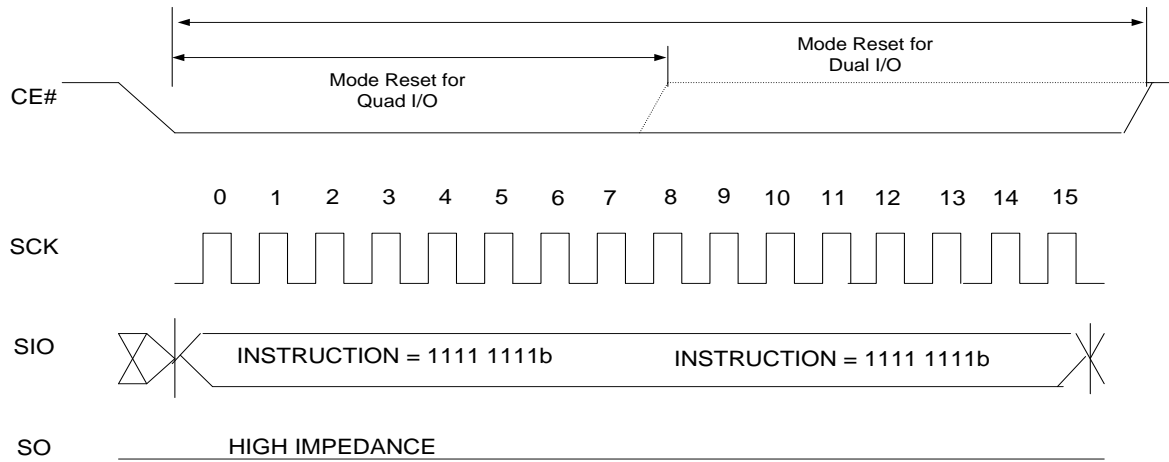
Figure 20, Mode Reset Command



DEVICE OPERATION (CONTINUED)

PAGE_PROG COMMAND (PAGE PROGRAM) OPERATION

The Page Program (PAGE_PROG) instruction allows up to 256 bytes data to be programmed into memory in a single operation. The destination of the memory to be programmed must be outside the protected memory area set by the Block Protection (BP3, BP2, BP1, BP0) bits. A PAGE_PROG instruction which attempts to program into a page that is write-protected will be ignored. Before the execution of PAGE_PROG instruction, the Write Enable Latch (WEL) must be enabled through a Write Enable (WREN) instruction.

The PAGE_PROG instruction code, three address bytes and program data (1 to 256 bytes) are input via the SI line. Program operation will start immediately after the CE# is brought high, otherwise the PAGE_PROG instruction will not be executed. The internal control logic automatically handles the programming voltages and timing. During a program operation, all instructions will be ignored except the RDSR instruction. The progress or completion of the program operation can be determined by reading the

WIP bit in Status Register via a RDSR instruction. If the WIP bit is "1", the program operation is still in progress. If WIP bit is "0", the program operation has completed.

If more than 256 bytes data are sent to a device, the address counter rolls over within the same page, the previously latched data are discarded, and the last 256 bytes data are kept to be programmed into the page. The starting byte can be anywhere within the page. When the end of the page is reached, the address will wrap around to the beginning of the same page. If the data to be programmed are less than a full page, the data of all other bytes on the same page will remain unchanged.

Note: A program operation can alter "1"s into "0"s, but an erase operation is required to change "0"s back to "1"s. A byte cannot be reprogrammed without first erasing the whole sector or block.

Figure 21. Page Program Sequence

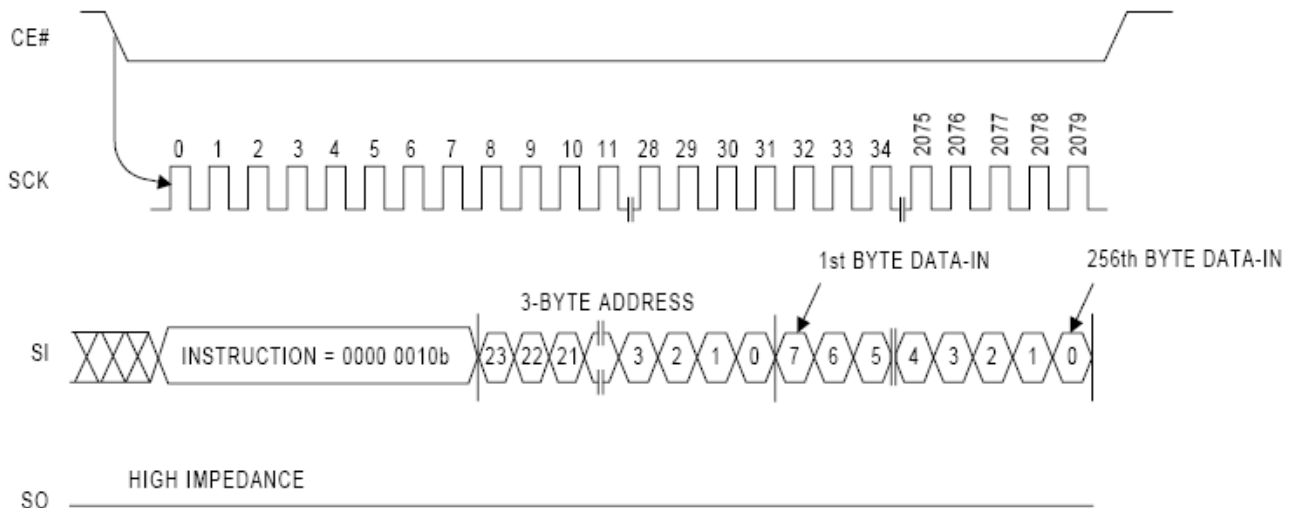

DEVICE OPERATION (CONTINUED)
Quad Input Page Program operation

The Quad Input Page Program instruction allows up to 256 bytes data to be programmed into memory in a single operation with four pins (IO0, IO1, IO2 and IO3). The destination of the memory to be programmed must be outside the protected memory area set by the Block Protection (BP3, BP2, BP1, BP0) bits. A Quad Input Page Program instruction which attempts to program into a page that is write-protected will be ignored. Before the execution of Quad Input Page Program instruction, the QE bit in the status register must be set to "1" and the Write Enable Latch (WEL) must be enabled through a Write Enable (WREN) instruction.

The Quad Input Page Program instruction code, three address bytes and program data (1 to 256 bytes) are input via the four pins (IO0, IO1, IO2 and IO3). Program operation will start immediately after the CE# is brought high, otherwise the Quad Input Page Program instruction will not be executed. The internal control logic automatically handles the programming voltages and timing. During a program operation, all instructions will be ignored except the

RDSR instruction. The progress or completion of the program operation can be determined by reading the WIP bit in Status Register via a RDSR instruction. If the WIP bit is "1", the program operation is still in progress. If WIP bit is "0", the program operation has completed.

If more than 256 bytes data are sent to a device, the address counter rolls over within the same page, the previously latched data are discarded, and the last 256 bytes data are kept to be programmed into the page. The starting byte can be anywhere within the page. When the end of the page is reached, the address will wrap around to the beginning of the same page. If the data to be programmed are less than a full page, the data of all other bytes on the same page will remain unchanged.

Note: A program operation can alter "1"s into "0"s, but an erase operation is required to change "0"s back to "1"s. A byte cannot be reprogrammed without first erasing the whole sector or block.

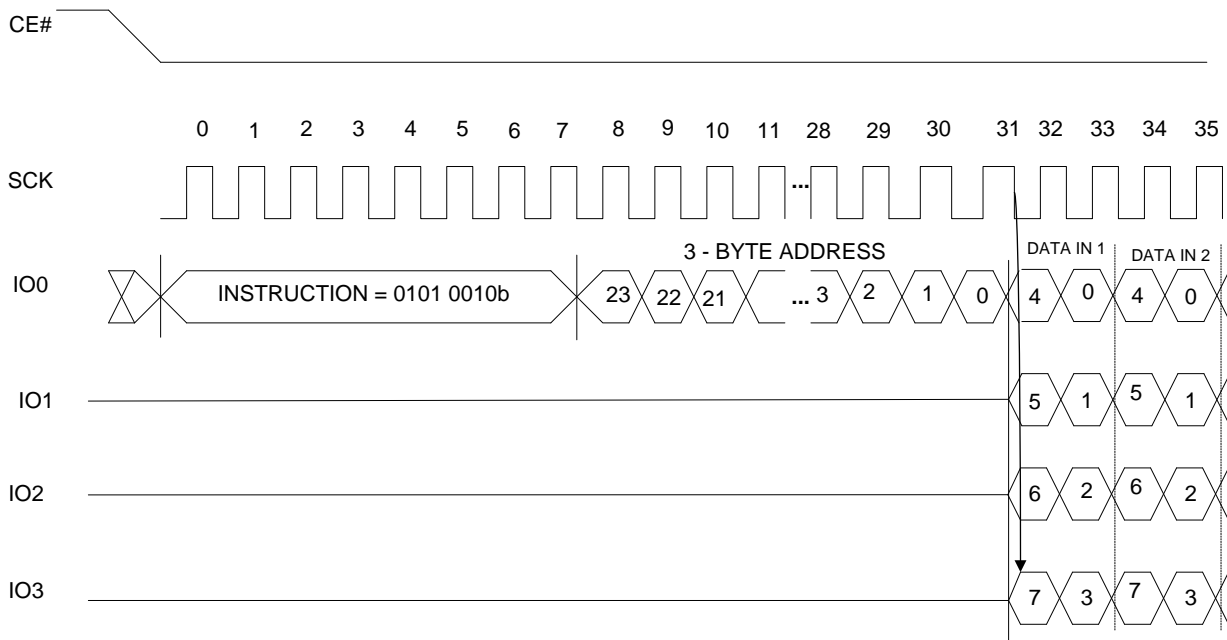

DEVICE OPERATION (CONTINUED)

ERASE OPERATION

The memory array of the IS25LQ020A is organized into uniform 4 KByte sectors or 32 KByte uniform blocks (64KByte Blocks for the 2Mb).

Before a byte can be reprogrammed, the sector or block that contains the byte must be erased (erasing sets bits to "1"). In order to erase the devices, there are three erase instructions available: Sector Erase (SECTOR_ER), Block Erase (BLOCK_ER) and Chip Erase (CHIP_ER). A sector erase operation allows any individual sector to be erased without affecting the data in other sectors. A block erase operation erases any individual block. A chip erase operation erases the whole memory array of a device. A sector erase, block erase or chip erase operation can be executed prior to any programming operation.

SECTOR_ER COMMAND (SECTOR ERASE) OPERATION

A SECTOR_ER instruction erases a 4 KByte sector. Before the execution of a SECTOR_ER instruction, the Write Enable Latch (WEL) must be set via a Write Enable (WREN) instruction. The WEL bit is reset automatically after the completion of sector an erase operation.

A SECTOR_ER instruction is entered, after CE# is pulled low to select the device and stays low during the entire instruction sequence. The SECTOR_ER instruction code, and three address bytes are input via SI. Erase operation will start immediately after CE# is pulled high. The internal control logic automatically handles the erase voltage and timing. Refer to Figure 22 for Sector Erase Sequence.

During an erase operation, all instruction will be ignored except the Read Status Register (RDSR) instruction. The progress or completion of the erase

operation can be determined by reading the WIP bit in the Status Register using a RDSR instruction. If the WIP bit is "1", the erase operation is still in progress. If the WIP bit is "0", the erase operation has been completed.

BLOCK_ER COMMAND (BLOCK ERASE) OPERATION

A Block Erase (BLOCK_ER) instruction erases a single block of the IS25LQ020A. Before the execution of a BLOCK_ER instruction, the Write Enable Latch (WEL) must be set via a Write Enable (WREN) instruction. The WEL is reset automatically after the completion of a block erase operation.

The BLOCK_ER instruction code and three address bytes are input via SI. Erase operation will start immediately after the CE# is pulled high, otherwise the BLOCK_ER instruction will not be executed. The internal control logic automatically handles the erase voltage and timing. Refer to Figure 23 for Block Erase Sequence.

CHIP_ER COMMAND (CHIP ERASE) OPERATION

A Chip Erase (CHIP_ER) instruction erases the entire memory array of a IS25LQ020A. Before the execution of CHIP_ER instruction, the Write Enable Latch (WEL) must be set via a Write Enable (WREN) instruction. The WEL is reset automatically after completion of a chip erase operation.

The CHIP_ER instruction code is input via the SI. Erase operation will start immediately after CE# is pulled high, otherwise the CHIP_ER instruction will not be executed. The internal control logic automatically handles the erase voltage and timing. Refer to Figure 24 for Chip Erase Sequence.

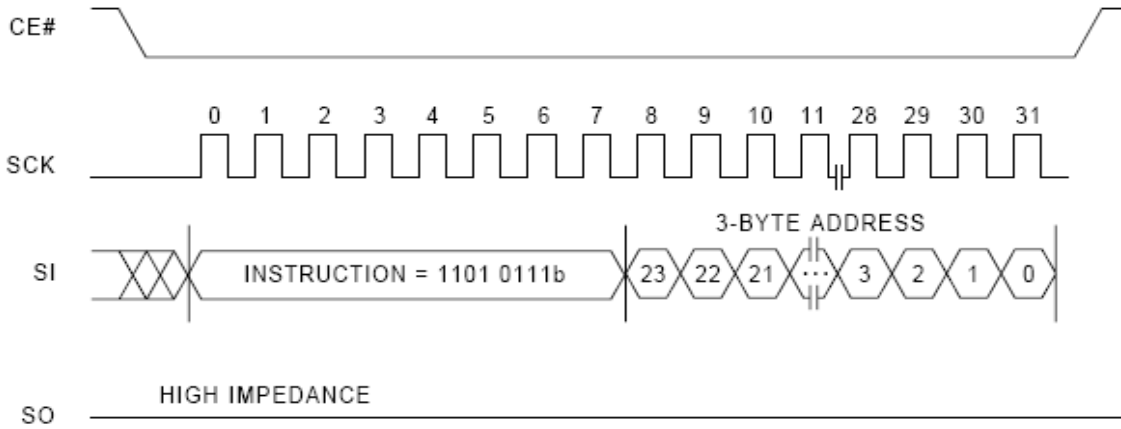
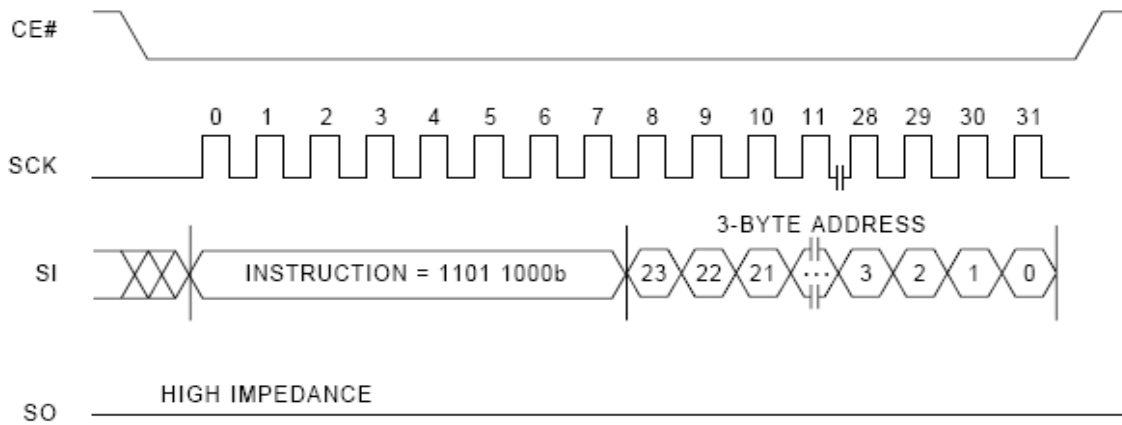
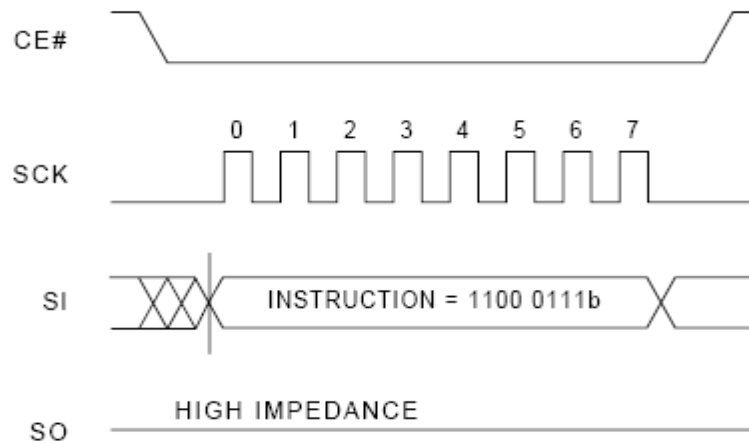
DEVICE OPERATION (CONTINUED)
Figure 22. Sector Erase Sequence

Figure 23. Block Erase Sequence

Figure 24. Chip Erase Sequence

DEVICE OPERATION (CONTINUED)
Program Security information Row instruction (PSIR)

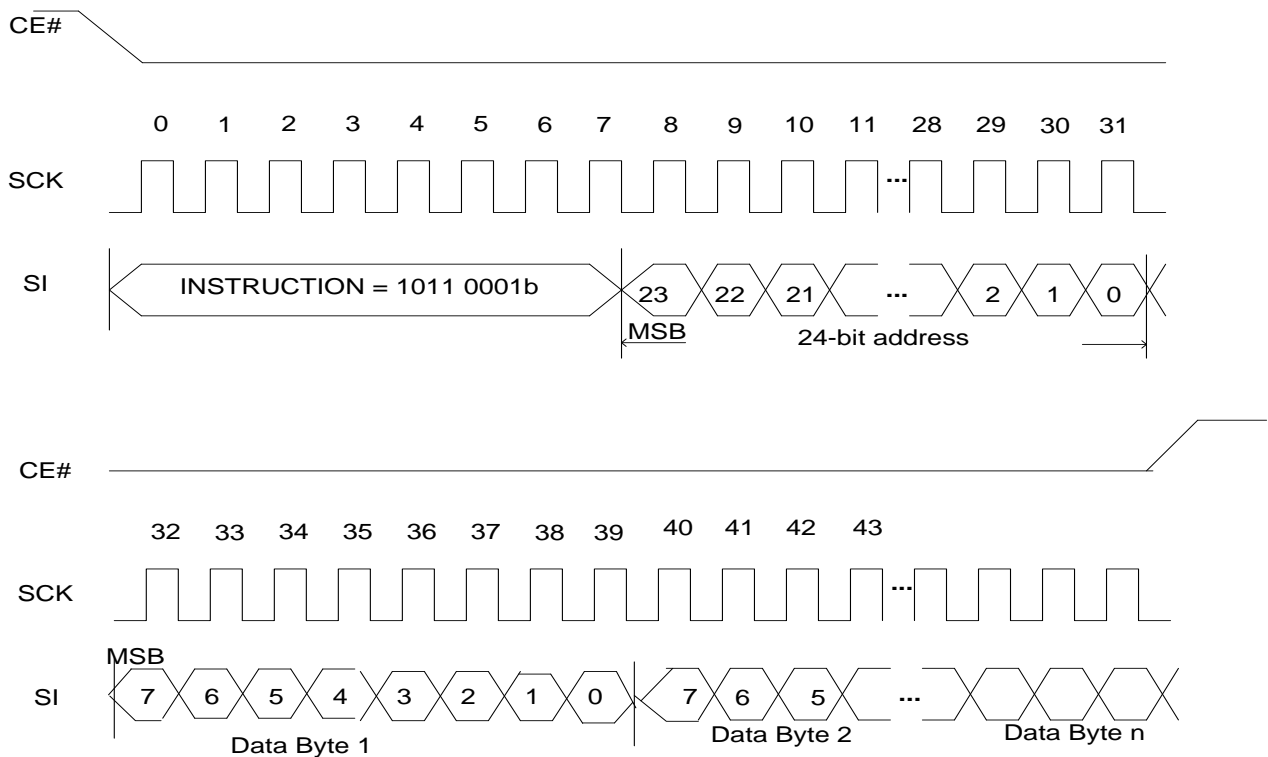
The PSIR instructions can read and programmed (Erase) using three dedicated instructions. The program information Row instruction is used to program at most 65 bytes to the security memory area (by changing bits from '1' to '0', only). Before it can be accepted, a write enable (WREN) instruction must previously have been executed. After the write enable (WREN) instruction has been decoded, the device sets the write enable latch (WEL) bit. The program information Row instruction is entered by driving CE# pin Low, followed by the instruction code, three address bytes and at least one data byte on serial data input (SI). CE# pin must be driven High after the eighth bits of the last data byte has been latched in, otherwise the Program information Row instruction is not executed. If more than 64 bytes data are sent to a device, the address counter can not roll over.

After CE# pin is driven High, the self-timed page program cycle (whose duration is t_{otp}) is initiated. While the program OTP cycle is in progress, the status register may be read to check the value of the write in progress (WIP) bit. The write in progress (WIP) bit is 1 during the self-timed program cycle, and it is 0 when it is completed. At some unspecified time before the cycle is complete, the write enable latch (WEL) bit is reset.



Note: $1 \leq n \leq 65$

Figure 30. Program information Row Sequence

- Note: 1. The SIR address is from 000000h to 00003Fh.
 2. The SIR protection bit is in the address 000040h

DEVICE OPERATION (CONTINUED)

To lock the OTP memory:

Bit 0 of the OTP control byte, that is byte 64, is used to permanently lock the OTP memory array.

- When bit 0 of byte 65 = '1', the 64 bytes of the OTP memory array can be programmed.
- When bit 0 of byte 65 = '0', the 64 bytes of the OTP memory array are read-only and cannot be programmed anymore.

Once a bit of the OTP memory has been programmed to '0', it can no longer be set to '1'. Therefore, as soon as bit 0 of byte 64 (control byte) is set to '0', the 64 bytes of the OTP memory array become read-only in a permanent way.

Any program OTP (POTP) instruction issued while an erase, program or write cycle is in progress is rejected without having any effect on the cycle that is in progress

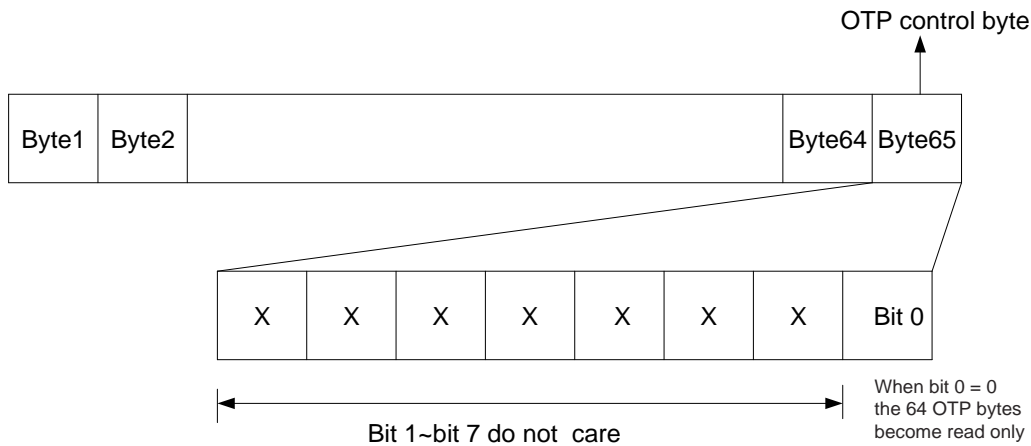

DEVICE OPERATION (CONTINUED)
Read Security Information Row (RSIR)

The RSIR instruction reads the security information Row. There is no rollover mechanism with the read OTP (ROTP) instruction. This means that the read OTP (ROTP) instruction must be sent with a maximum of 65 bytes to read, since once the 65th byte has been read, the same (65th) byte keeps being read on the SO pin.

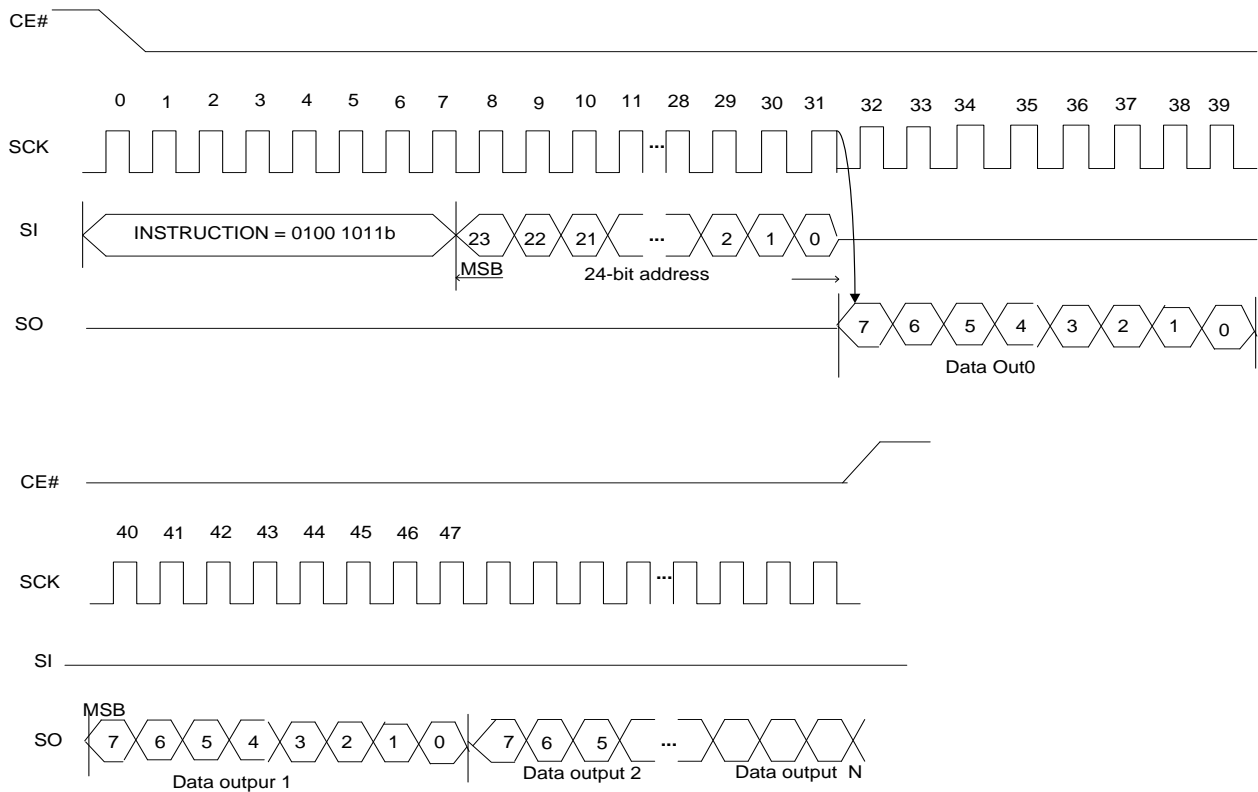
Fig 33. Read Security information Row instruction

**AC CHARACTERISTICS**

Applicable over recommended operating range from $T_A = -40^{\circ}\text{C}$ to $+105^{\circ}\text{C}$, $V_{CC} = 2.3\text{ V}$ to 3.6 V
 $C_L = 1\text{ TTL Gate}$ and 30 pF (unless otherwise noted).

Symbol	Parameter	Min	Typ	Max	Units
f _{CT}	Clock Frequency for fast read mode	0		80	MHz
f _C	Clock Frequency for read mode	0		33	MHz
t _{RI}	Input Rise Time			8	ns
t _{FI}	Input Fall Time			8	ns
t _{CKH}	SCK High Time	4			ns
t _{CKL}	SCK Low Time	4			ns
t _{CEH}	CE# High Time	25			ns
t _{CS}	CE# Setup Time	10			ns
t _{CH}	CE# Hold Time	5			ns
t _{DS}	Data In Setup Time	2			ns
t _{DH}	Data in Hold Time	2			ns
t _{HS}	Hold Setup Time	15			ns
t _{HD}	Hold Time	15			ns
t _V	Output Valid			8	ns
t _{OH}	Output Hold Time Normal Mode	0			ns
t _{LZ}	Hold to Output Low Z			200	ns
t _{HZ}	Hold to Output High Z			200	ns
t _{DIS}	Output Disable Time			100	ns
t _{EC}	Sector/Block/Chip Erase Time			10	ms
t _{PP}	Page Program Time		0.2	0.4	ms
t _{VCS}	V _{CC} Set-up Time	50			μs
t _w	Write Status Register time			2	ms

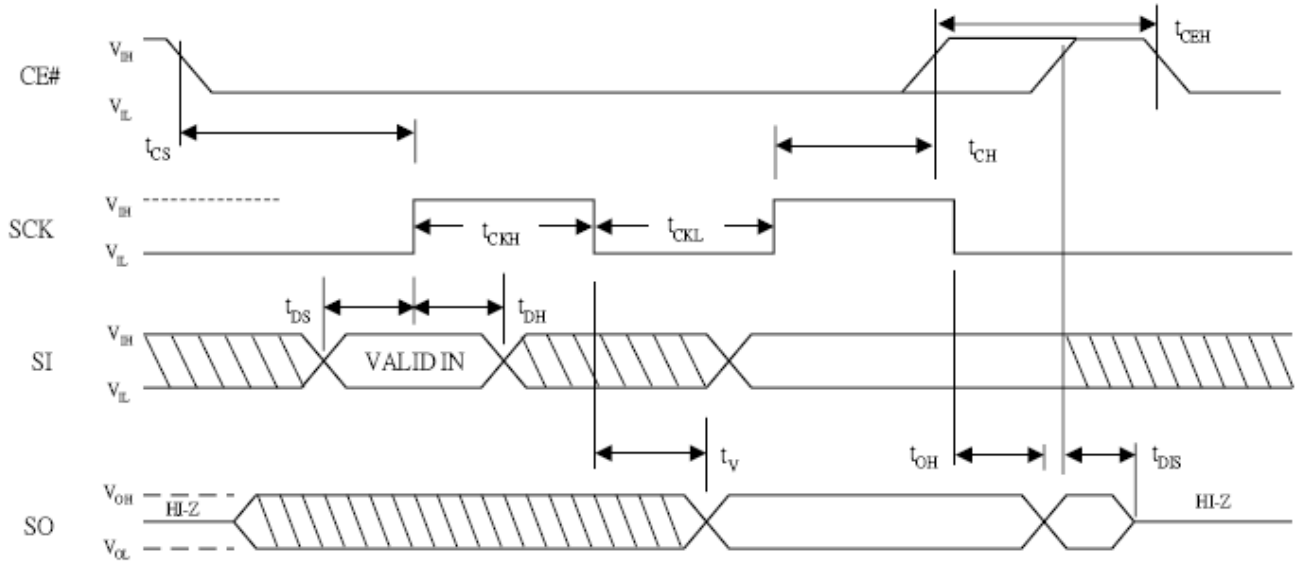
AC CHARACTERISTICS (CONTINUED)
SERIAL INPUT/OUTPUT TIMING ⁽¹⁾

Note: 1. For SPI Mode 0 (0,0)

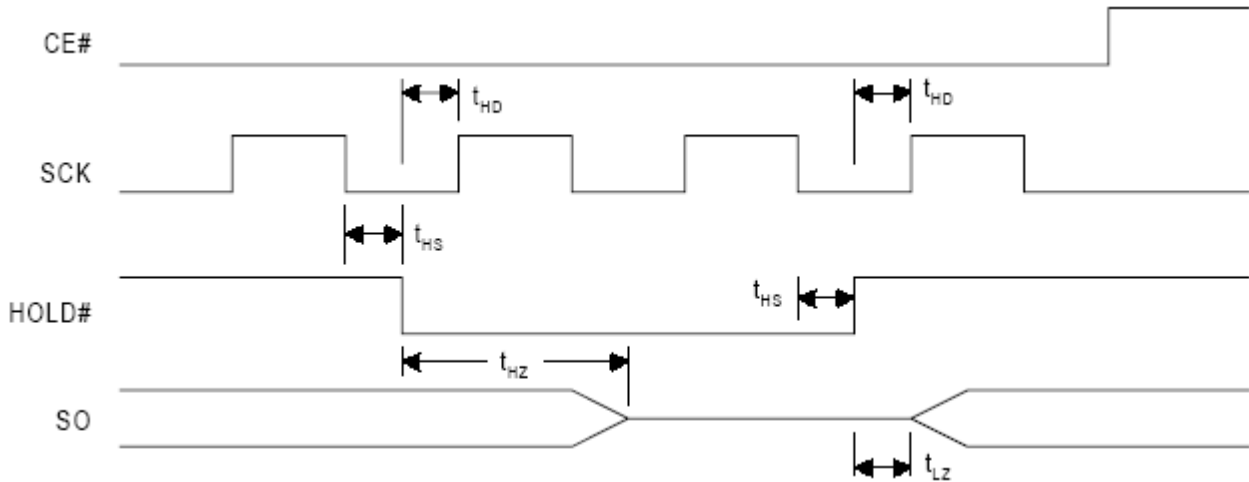
AC CHARACTERISTICS (CONTINUED)
HOLD TIMING

PIN CAPACITANCE (f = 1 MHz, T = 25°C)

	Typ	Max	Units	Conditions
C _{IN}	4	6	pF	V _{IN} = 0 V
C _{OUT}	8	12	pF	V _{OUT} = 0 V

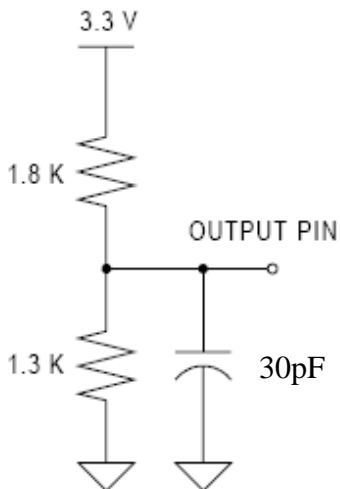
Note: These parameters are characterized but not 100% tested.

OUTPUT TEST LOAD

INPUT TEST WAVEFORMS AND MEASUREMENT LEVEL

- Note: 1. Input Pulse Voltage : 0.2V_{cc} to 0.8V_{cc}.
 2. Input Timing Reference Voltages : 0.3V_{cc} to 0.7V_{cc}.
 3. Output Timing Reference Voltage : V_{cc}/2.

POWER-UP AND POWER-DOWN

At Power-up and Power-down, the device must not be selected (CE# must follow the voltage applied on Vcc) until Vcc reaches the correct value:

- Vcc(min) at Power-up, and then for a further delay of tVCE
- Vss at Power-down

Usually a simple pull-up resistor on CE# can be used to insure safe and proper Power-up and Power-down. To avoid data corruption and inadvertent write operations during power up, a Power On Reset (POR) circuit is included. The logic inside the device is held reset while Vcc is less than the POR threshold value (Vwi) during power up, the device does not respond to any instruction until a time delay of tPUW has elapsed after the moment that Vcc rised above the VWI threshold. However, the correct operation of the device

is not guaranteed if, by this time, Vcc is still below Vcc(min). No Write Status Register, Program or Erase instructions should be sent until the later of:

- tPUW after Vcc passed the VWI threshold
- tVCE after Vcc passed the Vcc(min) level

At Power-up, the device is in the following state:

- The device is in the Standby mode
- The Write Enable Latch (WEL) bit is reset

At Power-down, when Vcc drops from the operating voltage, to below the Vwi, all write operations are disabled and the device does not respond to any write instruction.

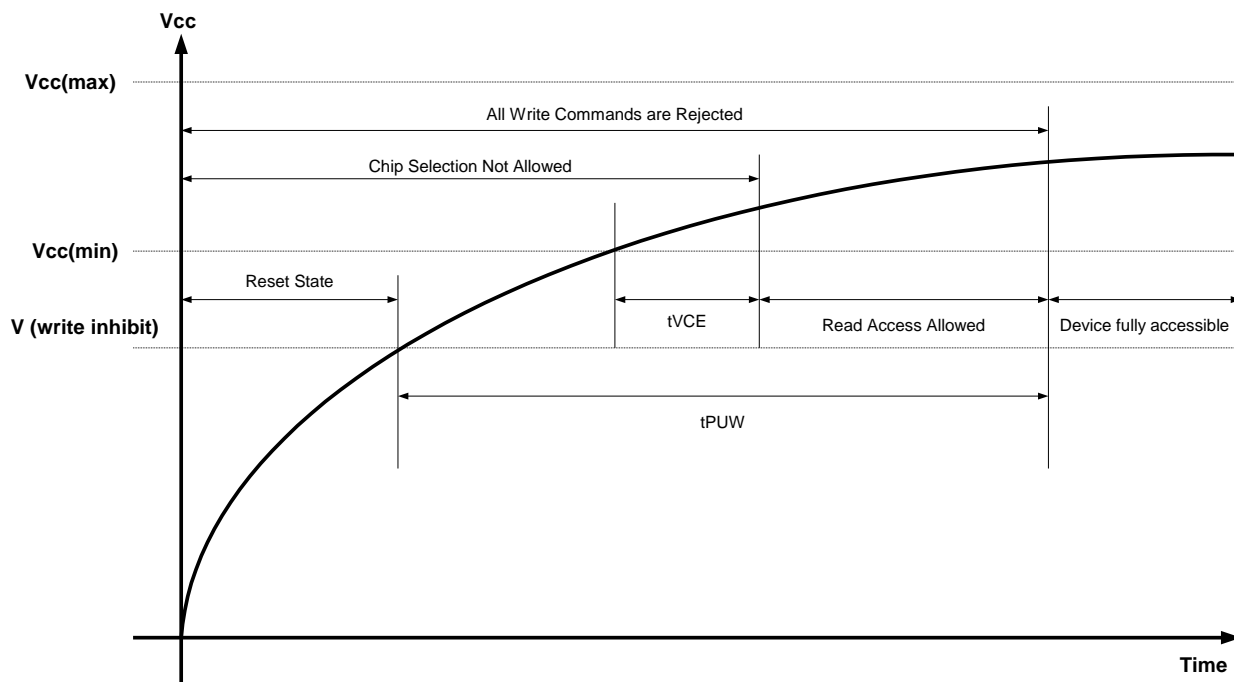

Symbol	Parameter	Min.	Max.	Unit
t _{VCE} ^{*1}	Vcc(min) to CE# Low	10		us
t _{PUW} ^{*1}	Power-Up time delay to Write instruction	1	10	ms
V _{WI} ^{*1}	Write Inhibit Voltage	2.0		V
Note : *1. These parameters are characterized only.				

PROGRAM/ERASE PERFORMANCE

Parameter	Unit	Typ	Max	Remarks
Sector Erase Time	ms		10	From writing erase command to erase completion
Block Erase Time	ms		10	From writing erase command to erase completion
Chip Erase Time	ms		10	From writing erase command to erase completion
Page Programming Time	ms	0.2	0.4	From writing program command to program completion

Note: These parameters are characterized and are not 100% tested.

RELIABILITY CHARACTERISTICS

Parameter	Min	Typ	Unit	Test Method
Endurance	100,000		Cycles	JEDEC Standard A117
Data Retention	20		Years	JEDEC Standard A103
ESD - Human Body Model	2,000		Volts	JEDEC Standard A114
ESD - Machine Model	200		Volts	JEDEC Standard A115
Latch-Up	100 + I _{CC1}		mA	JEDEC Standard 78

Note: These parameters are characterized and are not 100% tested.

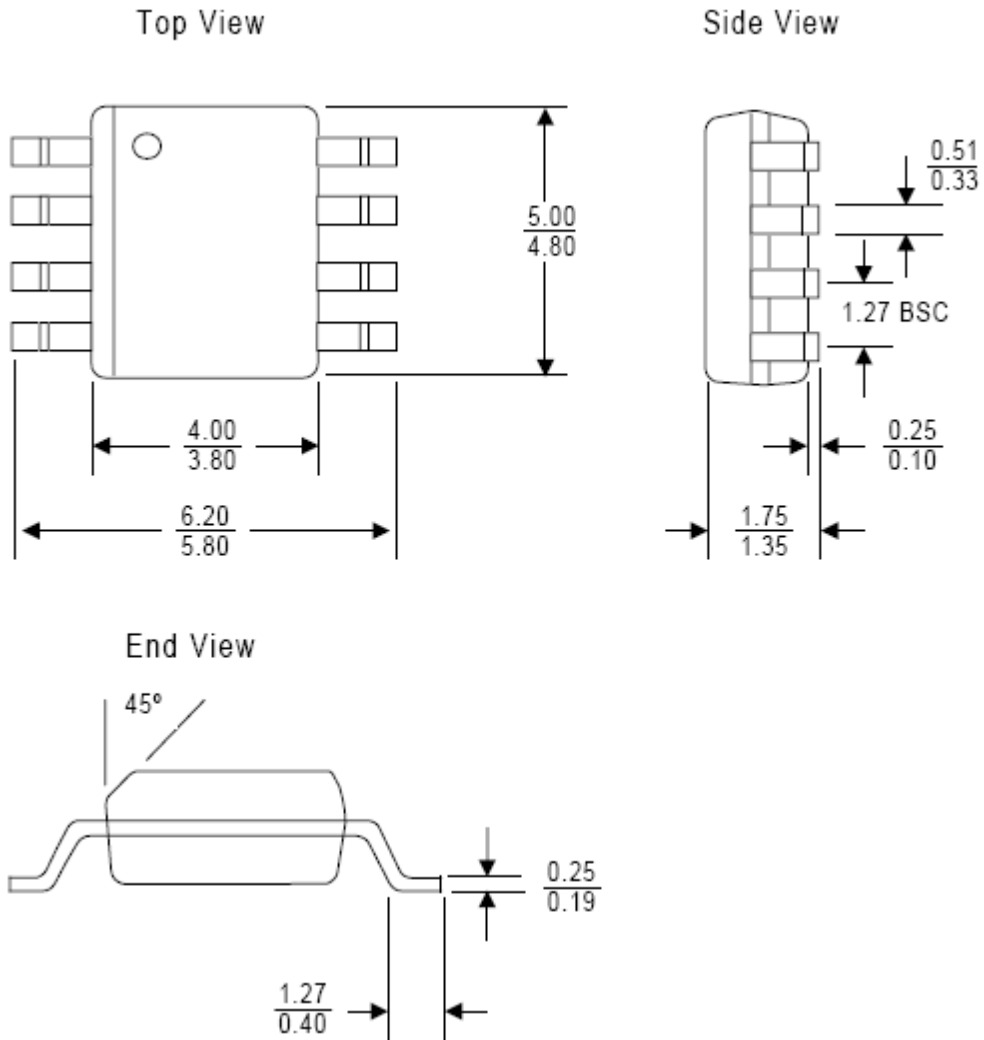
PACKAGE TYPE INFORMATION
**8-Pin JEDEC 150mil Small Outline Integrated Circuit (SOIC) Package
(measure in millimeters)**

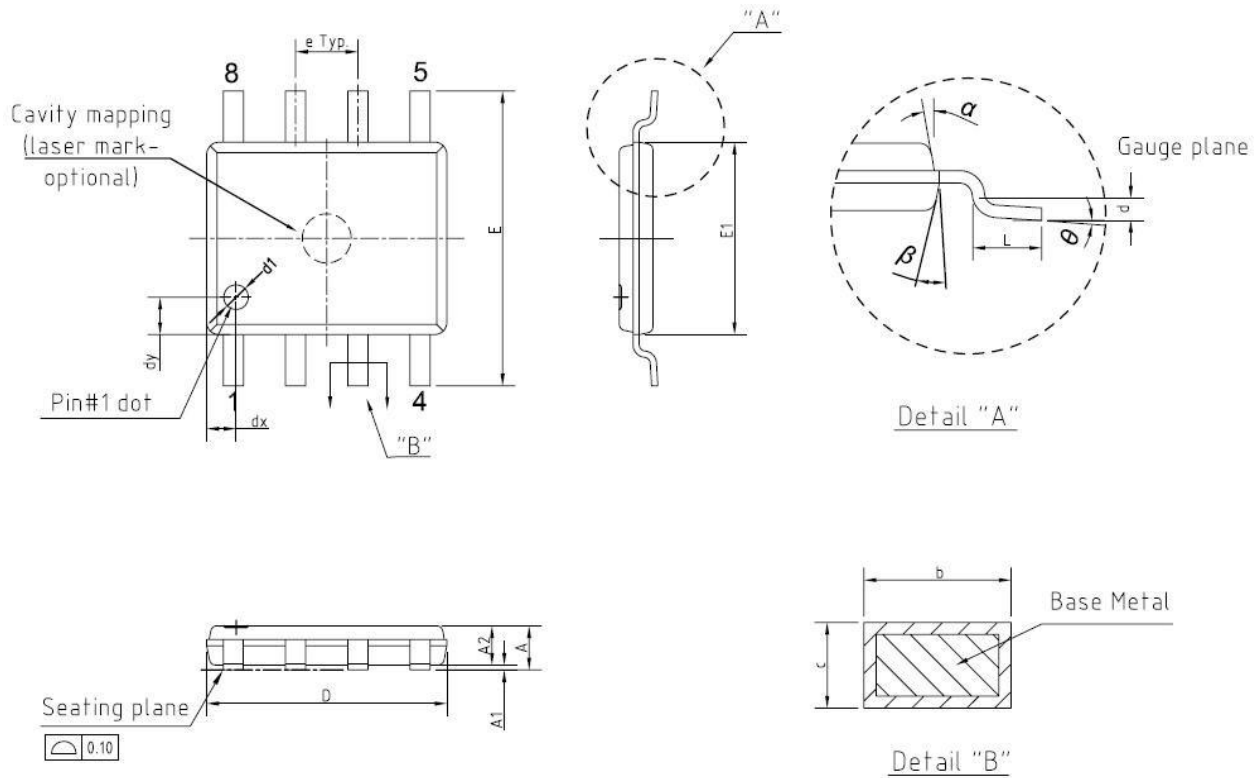
**8-Pin 150mil Very Small Outline Integrated Circuit (VVSOP) Package
(measure in millimeters)**

8-pin TSSOP Package (measure in millimeters)

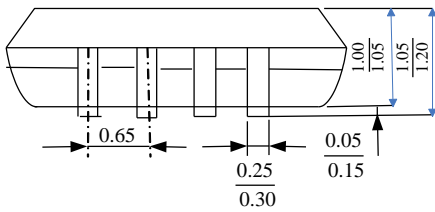
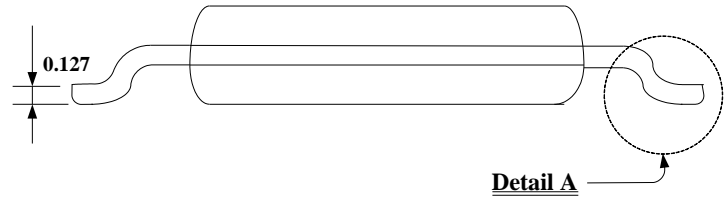
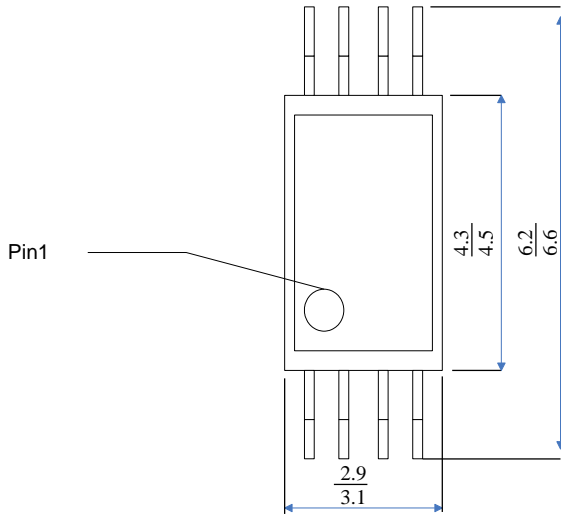

Detail A

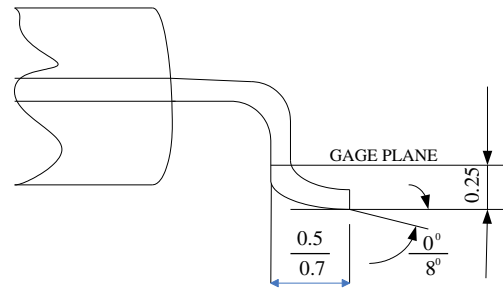

Unit : millimeters

Appendix1: Safe Guard function

Safe Guard function is a security function for customer to protect by sector (4Kbyte).

Every sector has a one bit register to decide if it will be safe guard protected or not. ("0" means protect and "1" means not protect by safe guard.) IS25LQ020A (sector 0~sector 63)

*safe guard function priority is higher than status register (BP0/1/2)

Mapping table for safe guard register

	Address[9:0]	D7	D6	D5	D4	D3	D2	D1	D0
Sector0	000h	1	1	1	1	1	1	1	0
Sector1	000h	1	1	1	1	1	1	0	1
Sector2	000h	1	1	1	1	1	0	1	1
Sector3	000h	1	1	1	1	0	1	1	1
Sector4	000h	1	1	1	0	1	1	1	1
Sector5	000h	1	1	0	1	1	1	1	1
Sector6	000h	1	0	1	1	1	1	1	1
Sector7	000h	0	1	1	1	1	1	1	1
Sector8	001h	1	1	1	1	1	1	1	0
Sector9	001h	1	1	1	1	1	1	0	1
Sector10	001h	1	1	1	1	1	0	1	1
Sector11	001h	1	1	1	1	0	1	1	1
Sector12	001h	1	1	1	0	1	1	1	1
Sector13	001h	1	1	0	1	1	1	1	1
Sector14	001h	1	0	1	1	1	1	1	1
Sector15	001h	0	1	1	1	1	1	1	1
⋮	⋮	⋮	⋮	⋮	⋮	⋮	⋮	⋮	⋮
Sector56	007h	1	1	1	1	1	1	1	0
Sector57	007h	1	1	1	1	1	1	0	1
Sector58	007h	1	1	1	1	1	0	1	1
Sector59	007h	1	1	1	1	0	1	1	1
Sector60	007h	1	1	1	0	1	1	1	1
Sector61	007h	1	1	0	1	1	1	1	1
Sector62	007h	1	0	1	1	1	1	1	1
Sector63	007h	0	1	1	1	1	1	1	1
Chip Erase disable*	008h	0	0	0	0	0	0	0	0

Note:1. Please set the Chip Erase disable to "00" after finished the register setting.

2. Please set the address 009h to "00" after finished the register setting.

Read Safe Guard register

The READ Safe Guard instruction code is transmitted via the SIO line, followed by three address bytes (A23 - A0) of the first register location to be read. The first byte data (D7 - D0) addressed is then shifted out on the SO line, MSb first. The address is automatically incremented after each byte of data is shifted out. The read operation can be terminated at any time by driving CE# high (V_{IH}) after the data comes out.

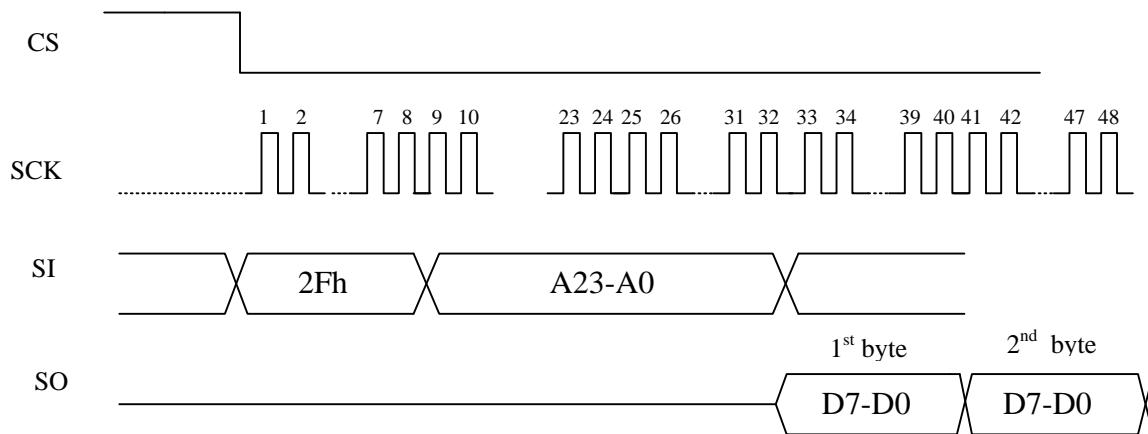

Fig a. Timing waveform of Read Safe guard register

Erase Safe Guard register

If we want to erase the safe guard register to let the flash into unprotect status, it needs five continuous instructions. If any instruction is wrong, the erase command will be ignored. Erase wait time follow product erase timing spec.

Fig b. shows the complete steps for Erase safe guard register.

Program Safe Guard register

If we want to erase the safe guard register to let the flash into unprotect status, it needs five continuous instructions. If any instruction is wrong, the program command will be ignored. The Program safe guard instruction allows up to 256 bytes data to be programmed into memory in a single operation. Program wait time follow product program timing spec.

Fig c. shows the complete steps for program safe guard register.

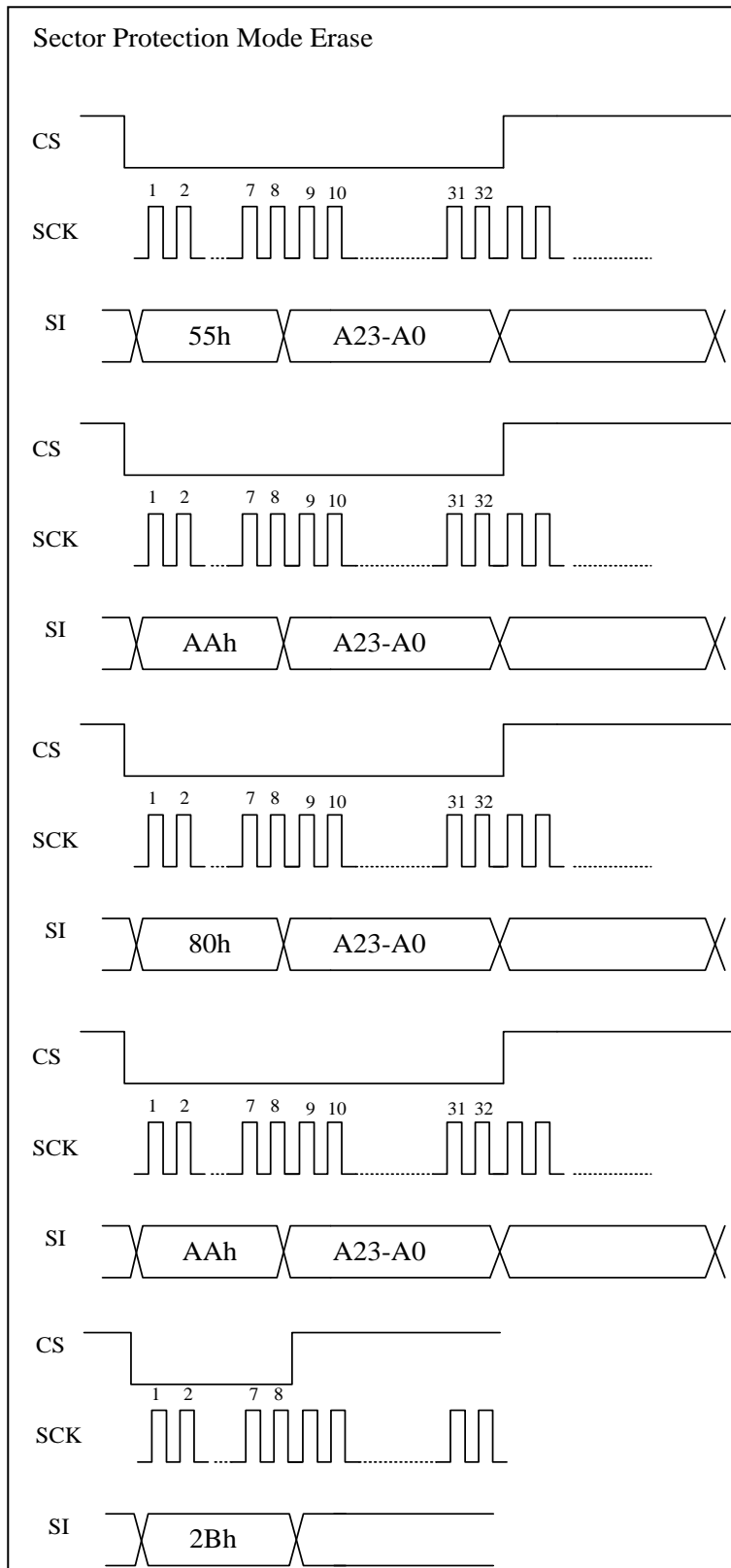

Fig b. Erase safe guard register

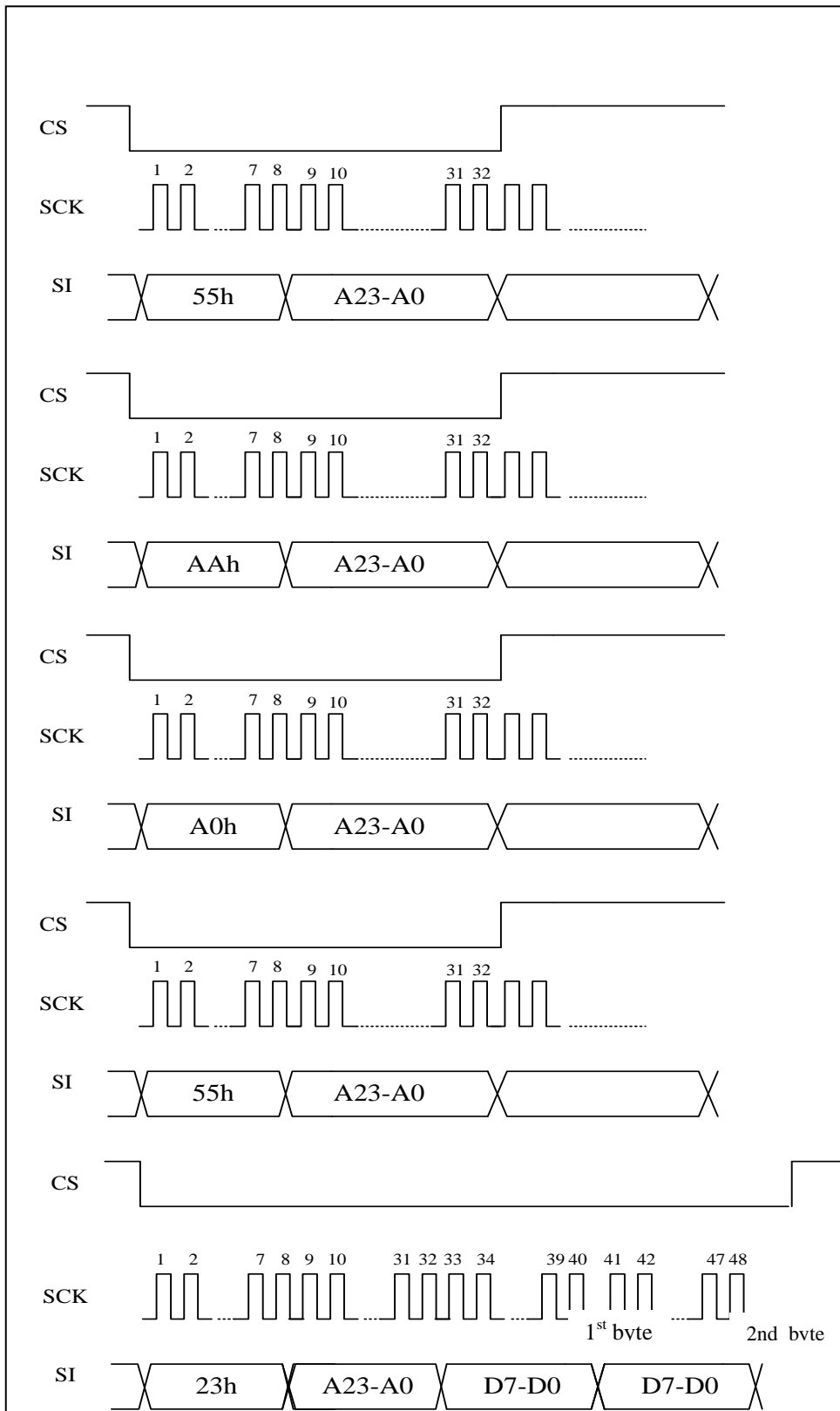

Fig c. program safe guard register

Appendix2: Sector Unlock function

Instruction Name	Hex Code	Operation	Command Cycle	Maximum Frequency
SECT_UNLOCK	26h	Sector unlock	4 Bytes	80 MHz
SECT_LOCK	24h	Sector lock	1 Byte	80 MHz

SEC_UNLOCK COMMAND OPERATION

The Sector unlock command allows the user to select a specific sector to allow program and erase operations. This instruction is effective when the blocks are designated as write-protected through the BP0, BP1 and BP2 bits in the status register. Only one sector can be enabled at any time. To enable a different sector, a previously enabled

sector must be disabled by executing a Sector Lock command. The instruction code is followed by a 24-bit address specifying the target sector, but A0 through A11 are not decoded. The remaining sectors within the same block remain in read-only mode.

Figure d. Sector Unlock Sequence

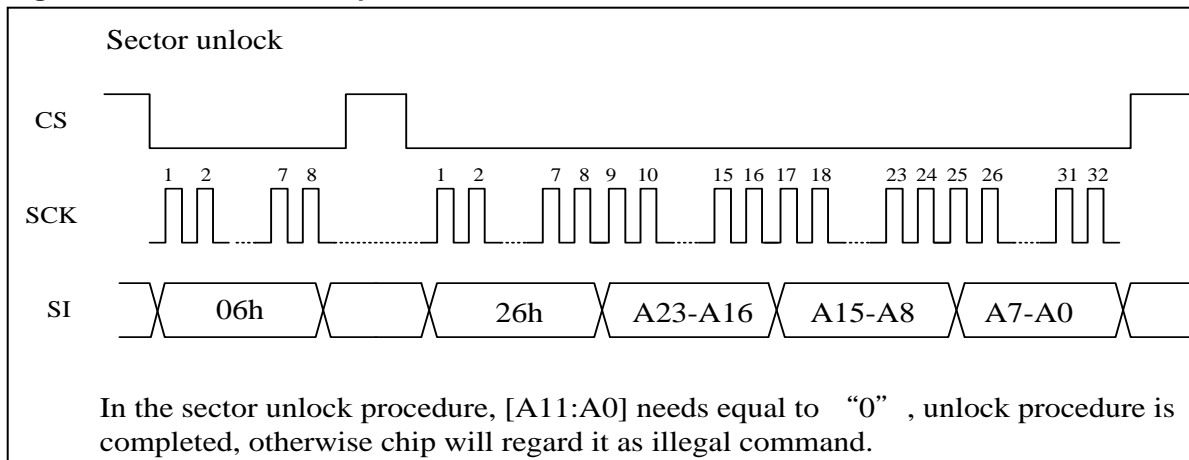

Note: 1.If the clock number will not match 8 clocks(command)+ 24 clocks (address), it will be ignored.
2.It must be executed write enable (06h) before sector unlock instructions.

SECT_LOCK COMMAND OPERATION

The Sector Lock command reverses the function of the Sector Unlock command. The instruction code does not require an address to be specified, as only

one sector can be enabled at a time. The remaining sectors within the same block remain in read-only mode.

Figure e. Sector Lock Sequence

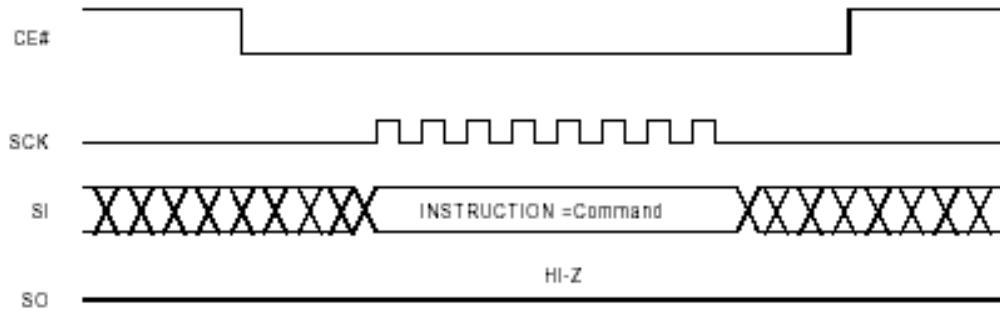



IS25LQ020A

Part Number	Operating Frequency (MHz)	Package	Temperature Range
IS25LQ020A-JNLE	80	8-Pin 150mil SOIC	-40°C to +105°C
IS25LQ020A-JVLE	80	8-Pin 150mil VVSOP	
IS25LQ020A-JDLE	80	8-Pin TSSOP	



Компания «ЭлектроПласт» предлагает заключение долгосрочных отношений при поставках импортных электронных компонентов на взаимовыгодных условиях!

Наши преимущества:

- Оперативные поставки широкого спектра электронных компонентов отечественного и импортного производства напрямую от производителей и с крупнейших мировых складов;
- Поставка более 17-ти миллионов наименований электронных компонентов;
- Поставка сложных, дефицитных, либо снятых с производства позиций;
- Оперативные сроки поставки под заказ (от 5 рабочих дней);
- Экспресс доставка в любую точку России;
- Техническая поддержка проекта, помощь в подборе аналогов, поставка прототипов;
- Система менеджмента качества сертифицирована по Международному стандарту ISO 9001;
- Лицензия ФСБ на осуществление работ с использованием сведений, составляющих государственную тайну;
- Поставка специализированных компонентов (Xilinx, Altera, Analog Devices, Intersil, Interpoint, Microsemi, Aeroflex, Peregrine, Syfer, Eurofarad, Texas Instrument, Miteq, Cobham, E2V, MA-COM, Hittite, Mini-Circuits, General Dynamics и др.);

Помимо этого, одним из направлений компании «ЭлектроПласт» является направление «Источники питания». Мы предлагаем Вам помощь Конструкторского отдела:

- Подбор оптимального решения, техническое обоснование при выборе компонента;
- Подбор аналогов;
- Консультации по применению компонента;
- Поставка образцов и прототипов;
- Техническая поддержка проекта;
- Защита от снятия компонента с производства.



Как с нами связаться

Телефон: 8 (812) 309 58 32 (многоканальный)

Факс: 8 (812) 320-02-42

Электронная почта: org@eplast1.ru

Адрес: 198099, г. Санкт-Петербург, ул. Калинина, дом 2, корпус 4, литера А.