



RoHS
Ready 

M Series Pin and Socket Connectors

M Series Connectors

Product Facts

- Most connectors intermateable with connectors made to MIL-C-28748 requirements
- Wide range of connector styles and sizes: standard connectors (unloaded), posted connectors (pre-loaded) and special application connectors (unloaded)
- Complete line of accessory hardware for fastening, protecting, guiding, shielding, strain relief and keying
- A variety of contacts: signal, power, coaxial and posted versions - many are interchangeable and can be intermixed in the same connector housing
- Full complement of application tooling for wire crimp and posted terminations - hand tools, semiautomatic tooling and fully automatic machines provide highly reliable, low cost terminations to meet production requirements

Need More Information?

Call the Technical Support Center:
1-800-522-6752.

The Center is staffed with specialists well versed in all AMP products and application tooling. The Center can provide you with:

- Technical Support
- Catalogs
- Technical Documents
- Product Samples
- AMP FAX Service
Product Information Faxed Immediately
- Authorized Distributor Locations

Specifications subject to change. Consult Tyco Electronics Corporation for latest design specifications.

©1968, 1970, 1972, 1974, 1978, 1985, 1990, 1996, 2001 and 2008 by Tyco Electronics Corporation. All Rights Reserved.
AMP, AMP FAX, AMPOMATOR, AMP-O-ELECTRIC, AMP-O-MATIC, AMP-TAPETRONIC, CERTI-CRIMP, COAXICON, LGH, POWERBAND, PRO-CRIMPER, RAYCHEM, TERMI-POINT and Tyco are trademarks.

Other products, logos, and company names mentioned herein may be trademarks of their respective owners.

Standard Housings



Posted Connectors



Special Application Connectors



Table of Contents

| | |
|--|--------|
| Product Facts | 2 |
| Introduction | 4, 5 |
| Material Specifications | 6 |
| Current Carrying Capabilities | 7, 8 |
| How to Use this Catalog | 9 |
| Connector/Hardware Selection Guide (for Typical Applications) | |
| Cable-to-Cable | 10-17 |
| Cable-to-Panel | 18-25 |
| Contacts (Description of Types) | 26-29 |
| Signal Contacts | |
| Type II, Crimp, Snap-In | 30 |
| Type III+, Crimp, Snap-In; Posted; Solder Versions | 31-35 |
| Power Contacts | |
| Type I, Crimp, Snap-In | 36 |
| High Current Type II and Type III+ (Screw Machine, Crimp, Snap-In). | 37 |
| Type XII, Crimp, Snap-In | 38 |
| Coaxial Contacts | |
| Subminiature, Crimp, Snap-In, Size 16 | 39, 40 |
| Miniature, Crimp, Snap-In, Size 12. | 41, 42 |
| Standard Housings—Introduction | 44 |
| 6, 14, and 20-Positions | 45 |
| 26, 34 and 36-Positions | 46, 47 |
| 41 and 50-Positions | 47, 48 |
| 75 and 104-Positions | 49 |
| 104 CF Positions (with Center Fastener) | 50 |
| 160 CF Positions (with Center Fastener) | 51 |
| Posted Connectors—Introduction | 52 |
| 6, 14, 20 and 26-Positions | 53, 54 |
| 34 and 50 Positions | 55, 56 |
| 75 and 104-Positions | 57 |
| 104 and 160 CF Positions (with Center Fastener) | 58, 59 |
| 15, 36 and 50 Positions (.200 [5.08] Grid). | 59, 60 |
| Special Application Connectors—Introduction | 61 |
| V.35 Special Application Connectors—Introduction | 62, 63 |
| V.35 Printed Circuit Board Connectors | 64-67 |
| V.35 Cable Connectors | 68-71 |
| 12-Positions, High Current Connector (UL Voltage Rating: 1800 V) | 72 |
| 29 CF Position Connector with Mixed Contacts (with Center Fastener). | 73 |
| 42-Positions, Connector with Mixed Contacts | 74 |
| 20-Positions, High Voltage Connector (UL Voltage Rating: 1800 V). | 75 |
| 28-Positions, High Voltage Connector (UL Voltage Rating: 1800 V). | 76 |
| 14 and 34-Positions, Grounding Blocks and Fastening Hardware | 77 |
| Hardware | |
| Fastening Hardware | 78-80 |
| Guiding Hardware | 81 |
| Protective Hardware | 82-87 |
| Strain Relief Hardware | 88 |
| Keying Hardware | 89 |
| Application Tooling | 90, 95 |
| Technical Documents | 96, 97 |
| Part Number Index | 98, 99 |

Introduction

AMP M Series connectors are one of the most versatile and complete pin and socket connector lines available today.

From the basic molded plastic housing, a connector can be built up with a wide choice of contacts and hardware to serve in applications ranging from sophisticated computers, medical instrumentation and military ground support equipment to rugged truck transmissions.

How this M Series catalog is divided

The M Series catalog is divided into six categories:

- Application section
- Contacts/Tooling
- Standard Connector Housings
- Posted Connector Housings
- Special Application Connector Housings
- Hardware

Following is a brief summary of each of the six categories.

Knowing what you need to meet your application is made easy

Eight applications have been illustrated with selection charts from pages 10 through 25. These charts will assist you to select the appropriate connector housing as well as the necessary hardware. Each base part number is listed in the numerical index on pages 94, 95 in order to find complete information about a particular part.

Contacts of various types provide different functions in M Series connector housings

Included are contacts for signal and power applications, for coaxial cable and posted versions for backpanel wiring. A full complement of application tooling is available to meet any production requirement for terminating the crimp-type contacts and wiring posted

contacts. A description of each contact type is presented on pages 26 through 29. Application tooling for these contacts is described on pages 90 and 91.

Standard connectors

Standard connectors are comprised of unloaded housings that accept a variety of crimp, solder and posted contacts. All standard connector housings will accept pins and/or sockets, permitting various combinations of contact loading. Standard connectors are described on pages 44 through 51.

Posted connectors

Posted connectors are preloaded with post-type contacts that accept TERMI-POINT Clip or wrap-type terminations. All posted connectors are described on pages 52 through 60.

Special Application connectors

Connectors for special application are available in the following configurations:

- V.35
- High Current
- Mixed Contact Connectors
- High Voltage
- RFI/EMI Shielded
- Grounding Blocks

Special Application Connectors are described on pages 61 through 77.

The right hardware for the entire M Series connector line

Hardware is available to provide fastening, protection, shielding, guiding, strain relief and keying capabilities for the entire M Series connector line. Application charts for properly selecting hardware are presented on pages 10 through 25. Detailed information on hardware is located on pages 78 through 89.

Introduction (Continued)

What makes the M Series connector line so versatile and special for a wide variety of applications?

- **Compatibility**—Most connectors intermateable with connectors made to MIL-C-28748 requirements.
- **Wide range**—Choice of connector styles and sizes: standard connectors (unloaded), posted connectors (preloaded) and special application connectors.
- **Complete line**—Full line of accessory hardware for fastening, protecting, guiding, strain relief and keying.
- **Variety of contacts**—Signal, power, coaxial, and posted versions—many are interchangeable and can be intermixed in the same connector housing.
- **Full complement of application tooling**—For wire crimp and posted terminations hand tools, semiautomatic tooling and fully automatic machines provide highly reliable, low cost terminations to meet production requirements.

How to choose the appropriate connector/contact/hardware combination

Choosing the appropriate connector/contact/hardware combination is essential to the proper function of any AMP M Series connector. First, a customer must evaluate each individual application with regards to: wire size(s); number of circuits; available space; fastening methods; and needs for protection, shielding, guiding, strain relief and keying. Then, the customer must consider the following factors to make the appropriate selection of M Series connectors and related components.

A - Determine Connector Type—

This decision is based on the selected contact types, circuit density requirements and, if posted connectors are desired, in-plant production capabilities for wiring connectors using hand tools or semiautomatic tooling. Detailed specifications of the various M Series connectors are presented on the following pages: Standard connectors (pages 44 through 51), Posted connectors (pages 52 through 60), Special Application connectors (pages 61 through 77).

B - Determine Hardware—

This decision is based on the selected connector types, and the individual application requirements for fastening, protection, shielding, guiding, strain relief and keying. To assist customers in determining the proper hardware to use, hardware selection information has been formulated for each connector type. This information is located on pages 10 through 25. Complete specifications of each hardware component are presented in the Hardware section of the catalog (pages 78 through 89).

C - Determine Contact Type -

This decision is based on wire size(s) and reliability and cost requirements of an application, as well as the customer's in-plant production capabilities. Complete specifications, including accepted wire sizes and available platings of all pin and socket contacts, are presented in the Contacts section of the catalog (pages 30 through 43). Application tooling for crimp- and post-type contacts is presented on pages 90 and 91).

Material Specifications

Contacts

The material composition and construction of AMP contacts encompass varying price ranges and performance characteristics. Specific materials and available platings and plating thicknesses of each contact type are provided on individual contact pages in the Contact section (pages 30 thru 43). A brief description of each contact type is presented on pages 26 through 29. Also, typical performance data of M Series connectors and contacts is shown below.

Housings

M Series connector housings are made of either diallyl phthalate (blue), general purpose phenolic (black) or polyester (black).

Diallyl phthalate housings are molded of material per MIL-M-14, Type SDG. These housings are ideally suited for use where adverse environmental conditions are an important factor. Their advantages include exceptional stability; excellent resistance to acids, alkalies and solvents; low moisture absorption; and good dielectric strength.

Phenolic housings are molded of material per

MIL-M-14, Type CFG. The performance characteristics of these housings make them an excellent choice for applications in which exceptional resistance to acids, alkalies or solvents is not of prime concern. Polyester housings are molded from a high temperature thermoplastic material per ASTM D3220. Polyester housings provide the high temperature characteristics of diallyl phthalate and phenolic, but with a higher impact strength.

Hardware

A variety of materials such as plated steel, stainless steel and aluminum, are used in the construction of M Series connector hardware. This provides for the proper operation and durability of each hardware component, while offering a choice of economies to satisfy particular application requirements. The materials of each hardware component are specified on the individual hardware component pages in the Hardware section (pages 78 through 89).

Performance Data

Temperature Rating:

Phenolic Housings, -55°C to +150°C
Diallyl Phthalate Housings, -65°C to +125°C
Polyester, -55°C to +130°C

Flammability Ratings: UL94V-0

Dielectric Withstanding Voltage (at sea level):

Type II Contacts, 1500 VAC, RMS
Type III+ Contacts, 900 VAC, RMS

Durability (Mating/Unmating):

Types II and III+ Contacts, Gold Plated: 500 cycles;
Types II and III+ Contacts, Tin Plated: 50 cycles;
Type I Contacts, Gold Plated: 100 cycles

Note: For detailed information on the above performance data and further information on other performance data such as Insulation Resistance, Thermal Shock, Moisture Resistance, Vibration and Physical Shock, request AMP Product Specification No. 108-10001.

• **Recognized under the Component Program of Underwriters Laboratories Inc. for 250 volts, File No. E28476** 

• **Certified by Canadian Standards Association File No. LR 7189** 

Contract Carrying Capabilities

The total current capacity of each contact in a given connector is dependent upon the heat rise resulting from the combination of electrical loads of the contacts in the connector arrangement and the maximum ambient temperature in which the connector will be operating. Caution must be taken to ensure that this combination of conditions does not cause the internal temperature of the connector to exceed the maximum operating temperature of the housing material. Several variables which must be considered when determining this maximum current capability for your application are:

- **Wire Size** - Larger wire will carry more current since it has less internal resistance to current flow and generates less heat. The wire also conducts heat away from the connector.
- **Connector Size** - In general, with more circuits in a connector, less current per contact can be carried.
- **Current Load Distribution** - Spreading those lines with greater current loads through-out the connector, particularly around the outer perimeter, will enhance heat dissipation.
- **Ambient Temperature** - With higher ambient temperatures, less current can be carried.

Current Rating Verification Can a contact rated at 10 amps carry 10 amps?

Maybe yes, but probably not. The reason lies in the test conditions used to rate the contact. If these conditions do not adequately reflect the application conditions, the actual allowable current levels may be lower than specified levels. For example, many manufacturers, including Tyco, test a single contact in air. This gives an accurate measure of the basic current-carrying capacity of the contact. Use the contact alone in air and it can certainly carry 10 amperes. Use it in a multi-position connector surrounded by other current-carrying contacts or in high ambient temperatures, and the contact should carry less current.

Similarly, as the contact ages and stress relaxation, environmental cycling, and other degradation factors take their toll, the contact's current-carrying capacity decreases. A prudent design must set current levels for such end-of-design-life (EODL) conditions.

Practical current-carrying capacity is not an absolute, but an application-dependent condition.

New Method Simplifies Ratings

To help the designer set the appropriate current level, Tyco has developed a method of specifying current-carrying capacity. This method takes into account the various application factors that influence current rating.

The method can be summarized as follows:

- The contact is aged to EODL conditions by durability cycling, thermal cycling, and environmental exposure.
- The contact's resistance stability is verified.
- The current necessary to produce the specified temperature rise is measured. This T-rise is usually 30°C.
- A rating factor is determined to allow derating of multiple contacts in the same housing and for different conductor sizes.

Temperature

One other factor influencing current levels is the maximum operating temperature, for example, 105°C. If the application has a high ambient temperature (over 75°C) the contact's T-rise is limited by the maximum operating temperature. For example, an application temperature of 90°C limits the contact T-rise to 15°C. Since current produces heat (the I²R law), the current must be lowered to limit the T-rise.

A contact's T-rise depends not only on its I²R Joule heating, but also on its ability to dissipate the heat. Consider a contact in a multi-contact housing. Joule heating in multiple contacts will raise the local ambient temperature. Since the contact will not be able to dissipate its own heat as well by convection, the maximum T-rise will be realized at a lower current level. Consequently, the allowable current level must be lower to maintain an acceptable T-rise.

For a given connector, the current level will be set by the loading density. A connector

containing 50% current-carrying contacts will permit higher currents (per contact) than a connector will at 75% loading. The loading percentage assumes an even distribution of contacts within the housing. If all 10 contacts are grouped together in one section of a 20-position connector, the loading density may approach 100%.

The Importance of EODL

As stated, T-rise in a contact depends on both resistance and current. As it ages, a contact's resistance will increase. The contact designer will specify a maximum resistance for the contact, this level is the end-of-design-life resistance. Before the contact is tested for current, Tyco subjects it to a sequence of tests that exercises the major failure mechanisms and thereby simulates EODL conditions. Conditioning includes mating cycling, industrial mixed-flowing gases, humidity and temperature cycling, and vibration to sequentially introduce wear, corrosion, stress relaxation, and mechanical disturbance.

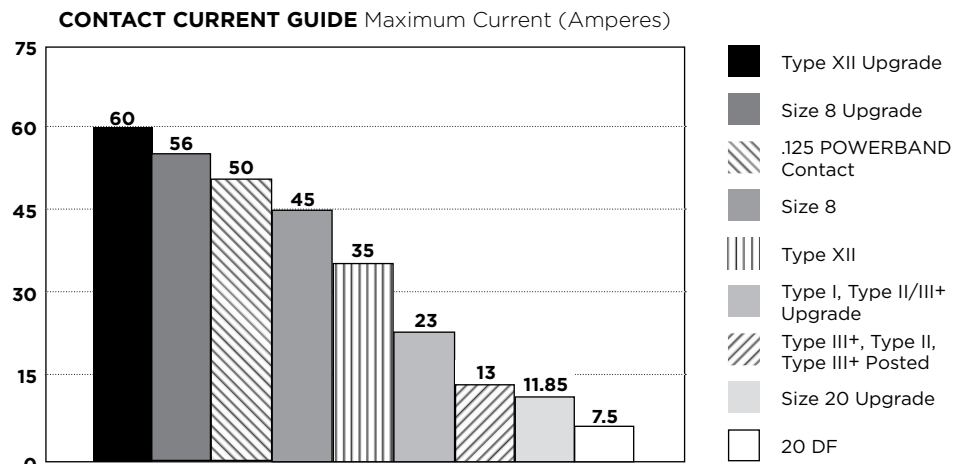

Presentation - Example of New Current Rating Format

The presentation of current-carrying capacity in AMP product specifications includes two parts:

- First, a base curve showing current levels versus T-rise for a single circuit and the largest wire size (See figure 1). This represents the maximum current capacity of the contact. The curve is usually flat up to 75°C ambient and then drops off. Up to 75°C, the 30°C T-rise limits the amount of current, and above 75°C the current must be reduced to keep the combination of ambient temperature and T-rise from exceeding the maximum operating temperature of 105°C.
- Next are rating factors; a table of multipliers to account for connector loading and for smaller wire sizes (See figure 2). The designer first determines the base current for the ambient conditions of the application; then multiplies this base current by the rating factors to find the current level for the application's loading factor and wire size.

Practical Values

The current-rating method gives designers practical values applicable to their applications. While the specified current levels for a contact may be lower than for other testing methods, they are more realistic and simplify the system design process. "Spec-manship" is replaced by a realistic assessment of the current-carrying capacity of a

Connector/Contact Acceptability

As previously stated, choosing the appropriate connector/contact combination is fundamental to the successful function of all connectors. The Selection Chart, shown at right, is designed to simplify your choice of connectors and their acceptable contacts. Once you have selected the wire size, current-carrying capacity need, number of positions required, and the type of contacts needed in your choice of connector, refer to this matrix for a quick look at exactly what is acceptable in a given connector type.

Note: Data is not typical of a specific M Series connector configuration. For specific current rating information based on % connector loading, contact Tyco Electronics.

To demonstrate the method of specifying current, consider the following application conditions; an ambient temperature of 65°C, a 50% loading of contacts in the housing, and 20 AWG [0.6mm²] wire.

- From Figure 1, the base current rating is 14 ampere with 18 AWG [0.8mm²] wire.
- Figure 2, the rating factor for 50% loading and 20 AWG [0.6mm²] wire is 0.68.
- The specific rating for this application is the product of the base rating and the rating factor:
 $14 \times 0.68 = 9.5$ ampere
- Each of the contacts can carry 9.5 ampere.
- However, if the ambient temperature is 80°C the allowable T-rise becomes 25°C. The base current must be lowered to 12.8 ampere so that the 105°C maximum operating temperature is not exceeded. The current rating then becomes:
 $12.8 \times 0.68 = 8.7$ ampere.

contact under varying conditions of temperature, connector loading, and wire size.

Specific current-carrying data based on EOL and % loading is available from Tyco Electronics Corporation. Please contact your local Sales Engineer or call Tyco Electronics Corporation.



Graph shows the relationship between base current, ambient temperature, and contact T-rise.



Figure 2
Rating factors allow the base current to be adjusted for various connector loading and wire sizes.

Contact Selection Chart

| Connector Type | Type I | Type II | High Current Type II/III | Type III+ | Posted Type III+ | Type XII | High Current Type XII | Mini-coax | Sub-Mini Coax |
|------------------|--------|---------|--------------------------|-----------|------------------|----------|-----------------------|-----------|---------------|
| M Series | | ✓ | ✓ | ✓ | ✓ | | | | ✓ |
| M Series Special | ✓ | ✓ | ✓ | ✓ | ✓ | ✓ | ✓ | ✓ | ✓ |

How to Use the M Series Connector Catalog

The information in this catalog has been arranged to assist the customer in selecting the connector and associated hardware that best satisfies their requirements.

Four cable-to-cable and four cable-to-panel applications utilizing the various types of fastening, guiding and protective hardware have been illustrated on pages 10 through 25.

After selecting the appropriate application to fit a particular requirement, refer to the indicated pages for component selection.

Posted connectors and Special Application connectors can be substituted for Standard Connectors where

indicated. Noted under each Special Application Connector is the standard size hardware used for that connector. Substitute into the appropriate column of the component selection charts.

The main portion of the catalog is divided into five basic sections: contacts, standard connectors, posted connectors, special application connectors and hardware. These sections contain brief descriptions, dimensions and other technical information. The remainder of the catalog contains application tooling information, a technical documents list and a numerical index which references pages covering all cataloged part numbers.

Cable-to-Cable

Application

A

Featured Hardware

- Strain Relief Clamps
- Locking Springs
- Pin Hoods
- Guide Hardware

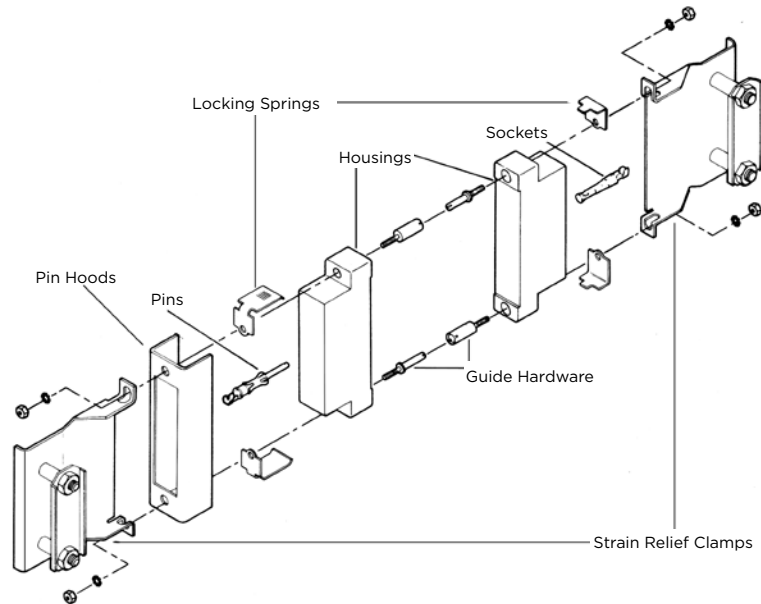

| Component Description | | Number of Positions | | | | |
|---|---|---------------------|----------|----------|-----------------------------|------------|
| | | 6 | 14 | 20 | 26 | 34 |
| STANDARD HOUSINGS Pages 44 to 51 | Plug Block } Phenolic | 202758-1 | 201355-1 | 201356-1 | 201359-1 | 1-201357-1 |
| | Receptacle Block } Phenolic | 202757-1 | 201298-1 | 200346-2 | 200512-2 | 200838-2 |
| | Plug Block } Diallyl Phthalate | 202758-3 | — | 201356-3 | 201359-3 | 201357-3 |
| | Receptacle Block } Diallyl Phthalate | 202757-3 | 201298-3 | 200346-4 | 200512-3 | 200838-3 |
| | Plug Block } Polyester | — | — | — | — | 2013800-1 |
| | Receptacle Block } Polyester | — | — | — | — | 200802-1 |
| STRAIN RELIEF CLAMPS Page 88 | Long } Nickel Plated Steel | — | 201843-3 | — | 201845-2 | 201846-5 |
| | Short } Nickel Plated Steel | 203432-1 | 200686-4 | — | 201229-5 | — |
| | Long } Stainless Steel | — | — | — | — | — |
| | Short } Stainless Steel | — | — | 201237-2 | — | 201224-7 |
| GUIDE HARDWARE Page 81 | Center Male } Stainless Steel | 200389-2 | 200389-2 | 200389-2 | 200389-2 | 200389-2 |
| | Center Female } Stainless Steel | 200390-9 | 200390-9 | 200390-9 | 200390-9 | 200390-9 |
| | Corner Male } Stainless Steel | — | — | — | — | 1-200833-1 |
| | Corner Female } Stainless Steel | — | — | — | — | 1-200835-1 |
| | | | | | | |
| LOCKING SPRINGS¹ Page 80 | Male—Nickel Plated Spring Steel | 201921-1 | 201921-1 | 201921-1 | 201923-1 | 201925-1 |
| | Female—Stainless Steel | 201922-1 | 201922-1 | 201922-1 | 201918-1 (Single Spring) | 201926-1 |
| PIN HOODS Pages 82 and 83 | Internal Open End Nickel Plated Steel | 204258-6 | 201363-4 | — | 201785-4 | 201786-4 |
| | Internal Closed End Nickel Plated Steel | — | — | — | — | — |
| | External Closed End Al Iridite | — | — | — | — | — |
| | External Closed End Nickel Plated Steel | — | — | — | — | — |

¹Each part number contains two locking springs. Order one male and one female for each mated pair of connectors.

Cable-to-Cable (Continued)

1. Confirm that **Application A** (at left) most closely meets your requirements. (Other applications are shown on pages 12 through 25.)
2. Find the appropriate column for the number of positions required.
3. Select part numbers required for the application listed in the column below the number of positions.
If a part number is not listed for a particular item, it is not available.
If more than one part number is listed for a particular hardware item, choose the one which best fits your application.
4. Dimensional information is available on the indicated pages under description column.
5. Select Contacts: Type II (page 30), Type III+ (pages 31 through 35) or Subminiature Coaxial (pages 40, 41).

Special application housings may be substituted for these standard housings. See Special Application Section.

This cable-to-cable application utilizes locking springs, strain relief clamps, a pin hood for pin protection and guide hardware.

The 34 and 50 position connectors can be used with either center or corner guide hardware. If center guide hardware is used, an additional four 4-40 screws, nuts and lockwashers are required to secure the locking springs. Corner guides require four guide pins and four guide sockets for each mated pair of connectors.

| Number of Positions | | | | | | Component Description | | |
|---------------------|------------|----|-----|------------|--------|--|---------------------|---|
| 41 | 50 | 75 | 104 | 104 CF | 160 CF | | | |
| 202135-2 | 201358-1 | — | — | — | — | Plug Block Receptacle Block | Phenolic | STANDARD HOUSINGS Pages 44 to 51 |
| 201302-1 | 200277-2 | — | — | — | — | | | |
| 202135-4 | 201358-3 | — | — | — | — | Plug Block Receptacle Block | Diallyl Phthalate | |
| 201302-3 | 200277-4 | — | — | — | — | | | |
| — | — | — | — | 1-201692-6 | — | Plug Block Receptacle Block | Polyester | |
| — | — | — | — | — | — | | | |
| — | — | — | — | — | — | Long Short | Nickel Plated Steel | |
| — | 201182-4 | — | — | — | — | | | |
| 201766-1 | 201847-1 | — | — | — | — | Long Short | Stainless Steel | |
| — | — | — | — | — | — | | | |
| 200389-2 | 200389-2 | — | — | — | — | Center Male Center Female Corner Male Corner Female | Stainless Steel | GUIDE HARDWARE Page 81 |
| 200390-9 | 200390-9 | — | — | — | — | | | |
| — | 1-200833-1 | — | — | — | — | | | |
| — | 1-200835-1 | — | — | — | — | | | |
| 201921-1 | 201925-1 | — | — | — | — | Male—Nickel Plated Spring Steel | | LOCKING SPRINGS¹ Page 80 |
| 201922-1 | 201926-1 | — | — | — | — | Female—Stainless Steel | | |
| — | — | — | — | — | — | Internal Open End | Nickel Plated Steel | PIN HOODS Pages 82 and 83 |
| — | — | — | — | — | — | Internal Closed End | Nickel Plated Steel | |
| — | — | — | — | — | — | External Closed End | Al Iridite | |
| — | — | — | — | — | — | External Closed End | Nickel Plated Steel | |

Cable-to-Cable (Continued)

Application

B

Featured Hardware

- Strain Relief Clamps
- Pin Hoods
- Jackscrews
- Guide Hardware



| Component Description | | Number of Positions | | | | | |
|--|--------------------------------|---|----------|----------|----------|----------|------------|
| | | 6 | 14 | 20 | 26 | 34 | |
| STANDARD HOUSINGS Pages 44 to 51 | Plug Block Receptacle Block | Phenolic | 202758-1 | 201355-1 | 201356-1 | 201359-1 | 1-201357-1 |
| | | | 202757-1 | 201298-1 | 200346-2 | 200512-2 | 200838-2 |
| | Plug Block Receptacle Block | Diallyl Phthalate | 202758-3 | — | 201356-3 | 201359-3 | 201357-3 |
| | | | 202757-3 | 201298-3 | 200346-4 | 200512-3 | 200838-3 |
| Plug Block Receptacle Block | Polyester | — | — | — | — | 213800-1 | |
| | | — | — | — | — | 213802-1 | |
| STRAIN RELIEF CLAMPS Page 88 | Long Short | Nickel Plated Steel | — | 201843-3 | — | 201845-2 | 201846-5 |
| | | | 203432-1 | 200686-4 | — | 201229-5 | — |
| | Long Short | Stainless Steel | — | — | — | — | — |
| | | | — | — | 201237-2 | — | 201224-7 |
| JACKSCREWS¹ Pages 78 and 79 | Fixed Male | Stainless Steel | 201092-4 | 201092-4 | 201092-4 | 201092-4 | 201092-4 |
| | Fixed Female | | 201089-4 | 201089-4 | 201089-4 | 201089-4 | 201089-4 |
| | Long-Long Male | Tip: Stainless Steel Body: Die Cast Zinc | — | — | — | — | — |
| | Long-Long Female | | — | — | — | — | — |
| | Long Male | | — | — | — | — | — |
| | Long Female | | — | — | — | — | — |
| | Short-Short Male | | 201827-1 | 201827-1 | 201827-1 | 201827-1 | 201827-1 |
| | Short-Short Female | | 201828-1 | 201828-1 | 201828-1 | 201828-1 | 201828-1 |
| GUIDE HARDWARE Page 81 | Center Male | Stainless Steel | — | — | — | — | — |
| | Center Female | | — | — | — | — | — |
| | Corner Male | | — | — | — | — | 1-200833-1 |
| | Corner Female | | — | — | — | — | 1-200835-1 |
| PIN HOODS Pages 82 and 83 | Internal Open End | Nickel Plated Steel | 204258-6 | 201363-4 | — | 201785-4 | 201786-4 |
| | Internal Closed End | Nickel Plated Steel | — | — | — | — | 202434-4 |
| | External Closed End | Al Iridite | — | — | — | 201349-2 | 201350-2 |
| | External Closed End | Nickel Plated Steel | — | — | — | — | — |

¹Listed Jackscrews have 6-32 single lead threads. For corresponding Jackscrews with 6-32 double lead threads, refer to pages 78 and 79.

Cable-to-Cable (Continued)

- Confirm that Application B (at left) most closely meets your requirements. (Other applications are shown on pages 10-11 and 14 through 25.)
- Find the appropriate column for the number of positions required.
- Select part numbers required for the application listed in the column below the number of positions.
If a part number is not listed for a particular item, it is not available.
If more than one part number is listed for a particular hardware item, choose the one which best fits your application.
- Dimensional information is available on the indicated pages under description column.
- Select Contacts: Type II (page 30), Type III+ (pages 31 through 35) or Subminiature Coaxial (pages 40, 41).

Special application housings may be substituted for these standard housings. See Special Application Section.

This cable-to-cable application utilizes jackscrews, strain relief clamps and guide hardware. A pin hood is provided for pin protection. Sizes 6, 14, 20, 26, and 41 **do not** use guide hardware with this application.

| Number of Positions | | | | | | Component Description | | |
|---------------------|------------|------------|------------|------------|--------|--|---|--|
| 41 | 50 | 75 | 104 | 104 CF | 160 CF | | | |
| 202135-2 | 201358-1 | 201310-1 | 201345-1 | — | — | Plug Block Receptacle Block | Phenolic | STANDARD HOUSINGS Pages 44 to 51 |
| 201302-1 | 200277-2 | 201311-1 | 201037-1 | — | — | Plug Block Receptacle Block | | |
| 202135-4 | 201358-3 | 201310-3 | 201345-2 | — | — | Plug Block Receptacle Block | Diallyl Phthalate | |
| 201302-3 | 200277-4 | 201311-3 | — | — | — | Plug Block Receptacle Block | Polyester | |
| — | — | — | — | 1-201692-6 | — | Plug Block Receptacle Block | | |
| — | — | — | 201849-1 | — | — | Long Short | Nickel Plated Steel | |
| — | 201182-4 | 200730-4 | — | — | — | Long Short | Stainless Steel | |
| 201766-1 | 201847-1 | 201848-5 | — | — | — | Long Short | Stainless Steel | |
| — | — | — | — | — | — | Fixed Male Fixed Female | Stainless Steel | |
| 201092-4 | 201092-4 | 201092-4 | 201092-4 | — | — | Long-Long Male Long-Long Female | Tip: Stainless Steel Body: Die Cast Zinc | |
| 201089-4 | 201089-4 | 201089-4 | 201089-4 | — | — | Long Male Long Female | | |
| — | — | — | — | — | — | Short-Short Male Short-Short Female | | |
| 201827-1 | 201827-1 | 201827-1 | 201827-1 | — | — | Center Male Center Female | | |
| 201828-1 | 201828-1 | 201828-1 | 201828-1 | — | — | Corner Male Corner Female | Stainless Steel | GUIDE HARDWARE Page 81 |
| — | 1-200833-1 | 1-201046-2 | 1-201046-2 | — | — | Internal Open End | Nickel Plated Steel | |
| — | 1-200835-1 | 201047-2 | 201047-2 | — | — | Internal Closed End | Nickel Plated Steel | PIN HOODS Pages 82 and 83 |
| — | — | — | — | — | — | External Closed End | Al Iridite | |
| — | 202394-2 | 201369-4 | 201364-4 | — | — | External Closed End | Nickel Plated Steel | |
| — | — | — | — | — | — | External Closed End | Al Iridite | |
| — | 201390-5 | 201368-4 | 201346-4 | — | — | External Closed End | Nickel Plated Steel | |

Cable-to-Cable (Continued)

Application



Featured Hardware

- Shields (One-piece)
- Pin Hoods
- Locking Springs
- Guide Hardware



| Component Description | | Number of Positions | | | | |
|--|--|--|----------|----------|------------|------------|
| | | 6 | 14 | 20 | 26 | 34 |
| STANDARD HOUSINGS Pages 44 to 51 | Plug Block Receptacle Block } Phenolic | — | 201355-1 | 201356-1 | 201359-1 | 1-201357-1 |
| | | — | 201298-1 | 200346-2 | 200512-2 | 200838-2 |
| | Plug Block Receptacle Block } Diallyl Phthalate | — | — | 201356-3 | 201359-3 | 201357-3 |
| | | — | 201298-3 | 200346-4 | 200512-3 | 200838-3 |
| | Plug Block Receptacle Block } Polyester | — | — | — | — | 213800-1 |
| | | — | — | — | — | 213802-1 |
| SHIELDS Pages 84 to 87 | 180° Two-Piece Long { | Al Anodized | — | — | — | — |
| | | Zinc Plated Steel | — | — | — | — |
| | 180° Two-Piece Short { | Al Anodized | — | — | — | — |
| | | Zinc Plated Steel | — | — | — | — |
| | | Zinc Plated Cast Al | — | — | — | — |
| | 90° Two-Piece Long 90° Two-Piece Short 45° Two-Piece Short 45° Two-Piece Deep 180° One-Piece Long 180° One-Piece Short 90° One-Piece Short } Nickel Plated Steel | — | — | — | — | — |
| | | — | — | — | — | — |
| | | — | — | — | — | — |
| | | — | 201378-2 | — | — | 201384-2 |
| | | — | 201360-2 | 201227-2 | 201169-2 | 201165-2 |
| | | — | — | 201460-2 | 201468-2 | 201469-2 |
| | GUIDE HARDWARE Page 81 | Center Male Center Female } Stainless Steel | — | 200389-2 | 200389-2 | 200389-2 |
| Corner Male Corner Female } | | — | 200390-2 | 200390-2 | 200390-2 | 200390-2 |
| — | | — | — | — | 1-200833-1 | |
| — | | — | — | — | 1-200835-1 | |
| LOCKING SPRINGS ¹ Page 80 | Male—Nickel Plated Spring Steel | — | 201921-1 | 201921-1 | 201923-1 | 201925-1 |
| | Female—Stainless Steel | — | 201922-1 | 201922-1 | — | 201926-1 |
| PIN HOODS Pages 82 and 83 | Internal Open End Nickel Plated Steel | — | 201363-4 | — | 201785-4 | 201786-4 |
| | Internal Closed End Nickel Plated Steel | — | — | — | — | — |
| | External Closed End Al Iridite | — | — | — | — | — |
| | External Closed End Nickel Plated Steel | — | — | — | — | — |

¹Each part number contains two locking springs. Order one male and one female for each mated pair of connectors.

Cable-to-Cable (Continued)

1. Confirm that Application C (at left) most closely meets your requirements. (Other applications are shown on pages 10-13 and 16 through 25.)
2. Find the appropriate column for the number of positions required.
3. Select part numbers required for the application listed in the column below the number of positions.
If a part number is not listed for a particular item, it is not available.
If more than one part number is listed for a particular hardware item, choose the one which best fits your application.
4. Dimensional information is available on the indicated pages under description column.
5. Select Contacts: Type II (page 30), Type III+ (pages 31 through 35) or Subminiature Coaxial (pages 40, 41).

Special application housings may be substituted for these standard housings. See Special Application Section.

This cable-to-cable application utilizes locking springs, one-piece shields, a pin hood for pin protection and guide hardware. The shields are available with both 180° and 90° cable exits. The 180° shields are available in a long version which provides pin protection in lieu of a pin hood.

A short shield and a pin hood or a long shield can be used on one side only of a mated pair of connectors. The mating connector must use a short shield.

The 34 and 50 position connectors can be used with either center or corner guide hardware. If center guides are used, an additional four 4-40 screws are required to secure the locking springs. If corner guides are used, an additional two 4-40 screws will be required to attach the shield. Corner guides require four guide pins and four guide sockets for each mated pair of connectors.

| | | Number of Positions | | | | | | Component Description | | |
|----------|------------|---------------------|-----|------------|--------|--|---|-----------------------|--|---|
| 41 | 50 | 75 | 104 | 104 CF | 160 CF | | | | | |
| 202135-2 | 201358-1 | — | — | — | — | Plug Block Receptacle Block | Phenolic | | | STANDARD HOUSINGS Pages 44 to 51 |
| 201302-1 | 200277-2 | — | — | — | — | | | | | |
| 202135-4 | 201358-3 | — | — | — | — | Plug Block Receptacle Block | Diallyl Phthalate | | | |
| 201302-3 | 200277-4 | — | — | — | — | | | | | |
| — | — | — | — | 1-201692-6 | — | Plug Block Receptacle Block | Polyester | | | |
| — | — | — | — | — | — | | | | | |
| — | — | — | — | — | — | 180° Two- Piece Long | Al Anodized Zinc Plated Steel | | | |
| — | — | — | — | — | — | | | | | |
| — | — | — | — | — | — | 180° Two- Piece Short | Al Anodized Zinc Plated Steel Zinc Plated Cast Al | | | |
| — | — | — | — | — | — | | | | | |
| — | — | — | — | — | — | 90° Two-Piece Long 90° Two-Piece Short 45° Two-Piece Short 45° Two-Piece Deep 180° One-Piece Long 180° One-Piece Short 90° One-Piece Short | Nickel Plated Steel | | SHIELDS Pages 84 to 87 | |
| — | — | — | — | — | — | | | | | |
| — | — | — | — | — | — | | | | | |
| — | — | — | — | — | — | | | | | |
| — | — | — | — | — | — | | | | | |
| 201486-2 | 201470-2 | — | — | — | — | Center Male Center Female | Stainless Steel | | | GUIDE HARDWARE Page 81 |
| 200389-2 | 200389-2 | — | — | — | — | | | | | |
| 200390-2 | 200390-2 | — | — | — | — | Corner Male Corner Female | | | | |
| — | 1-200833-1 | — | — | — | — | | | | | |
| — | 1-200835-1 | — | — | — | — | | | | | |
| 201921-1 | 201925-1 | — | — | — | — | Male—Nickel Plated Spring Steel | | | LOCKING SPRINGS¹ Page 80 | |
| 201922-1 | 201926-1 | — | — | — | — | Female—Stainless Steel | | | | |
| — | — | — | — | — | — | Internal Open End | Nickel Plated Steel | | PIN HOODS Pages 82 and 83 | |
| — | — | — | — | — | — | Internal Closed End | Nickel Plated Steel | | | |
| — | — | — | — | — | — | External Closed End | Al Iridite | | | |
| — | — | — | — | — | — | External Closed End | Nickel Plated Steel | | | |

Cable-to-Cable (Continued)

Application

D

Featured Hardware

- Shields (Two-piece)
- Pin Hoods
- Jackscrews
- Strain Relief Clamps
- Guide Hardware



| Component Description | Number of Positions | | | | | |
|--|---|--|--------------------|----------|----------|------------|
| | 6 | 14 | 20 | 26 | 34 | |
| STANDARD HOUSINGS Pages 44 to 51 | Plug Block } Phenolic | Receptacle Block | — | 201356-1 | 201359-1 | 1-201357-1 |
| | | Receptacle Block | — | 200346-2 | 200512-2 | 200838-2 |
| | Plug Block } Diallyl Phthalate | Receptacle Block | — | 201356-3 | 201359-3 | 201357-3 |
| | | Receptacle Block | — | 200346-4 | 200512-3 | 200838-3 |
| SHIELDS Pages 84 to 87 | 180° Two-Piece Long } Al Anodized | Nickel Plated Steel | — | — | 201576-1 | 201571-1 |
| | | Nickel Plated Steel | — | — | 201576-2 | 201571-2 |
| | 180° Two-Piece Short } Al Anodized | Nickel Plated Steel | — | — | — | 200517-1 |
| | | Nickel Plated Cast Al | — | 204087-1 | 200514-2 | 200517-9 |
| | 90° Two-Piece Long | — | — | — | — | |
| | 90° Two-Piece Short | — | — | — | — | |
| | 45° Two-Piece Short } Nickel Plated Steel | 45° Two-Piece Deep | — | — | — | — |
| | | 180° One-Piece Long | — | — | — | — |
| | | 180° One-Piece Short | — | — | — | — |
| | | 90° One-Piece Short | — | — | — | — |
| STRAIN RELIEF CLAMPS Page 88 | Long } Nickel Plated Steel | Short | — | — | 201845-2 | 201846-5 |
| | | Short | — | — | 201229-5 | — |
| | Long } Stainless Steel | Short | — | — | — | — |
| | | Short | — | 201237-2 | — | 201224-7 |
| JACKSCREWS¹ Pages 78 and 79 | Fixed Male } Stainless Steel | Fixed Female | — | 201092-4 | 201092-4 | 201092-4 |
| | | Fixed Female | — | 201089-4 | 201089-4 | 201089-4 |
| | Long-Long Male } Tip: Stainless Steel | Long-Long Female | — | — | — | — |
| | | Long Male | — | 201413-4 | 201413-4 | 201413-4 |
| | | Long Female | — | 201414-4 | 201414-4 | 201414-4 |
| | | Short-Short Male } Body: Die Cast Zinc | Short-Short Female | — | — | — |
| GUIDE HARDWARE Page 81 | Center Male } Stainless Steel | Center Female | — | — | — | — |
| | | Corner Male | — | — | — | 1-200833-1 |
| | Corner Female | Corner Female | — | — | — | 1-200835-1 |
| | | Corner Female | — | — | — | — |
| PIN HOODS Pages 82 and 83 | Internal Open End | Nickel Plated Steel | — | — | — | 201786-4 |
| | Internal Closed End | Nickel Plated Steel | — | — | — | 202434-4 |
| | External Closed End | Al Iridite | — | — | — | 201350-2 |
| | External Closed End | Nickel Plated Steel | — | — | — | — |

¹Listed Jackscrews have 6-32 single lead threads. For corresponding Jackscrews with 6-32 double lead threads, refer to pages 78 and 79. Erat veliquate magnibh enit, conullam vel ea feuguercip exerilli quatio er sequisci essismod magna feuis aliquatue feugait velestrud tinci tat. Duismodigna ad magna consequat ex eu feugait wis

Cable-to-Cable (Continued)

1. Confirm that Application D (at left) most closely meets your requirements. (Other applications are shown on pages 10-15 and 18 through 25.)
2. Find the appropriate column for the number of positions required.
3. Select part numbers required for the application listed in the column below the number of positions.
If a part number is not listed for a particular item, it is not available.
If more than one part number is listed for a particular hardware item, choose the one which best fits your application.
4. Dimensional information is available on the indicated pages under description column.
5. Select Contacts: Type II (page 30), Type III+ (pages 31 through 35) or Subminiature Coaxial (pages 40, 41).

Special application housings may be substituted for these standard housings. See Special Application Section.

This cable-to-cable application utilizes jackscrews, a two-piece short shield, a strain relief clamp, a pin hood for pin protection and guide hardware.

Do not use a pin hood in combination with the shield for sizes 20, 26 and 41. A long shield may be used in lieu of pin hood for pin protection for all sizes except the 20 position. Shields are available with 180° cable exit and for the 50 through 104 position connectors, a 90° cable exit.

Select the appropriate jackscrew length for the type of shield chosen as indicated by symbol (Δ▲).

| Number of Positions | | | | | | Component Description | |
|---------------------|------------|------------|------------|------------|--------|--------------------------------|---|
| 41 | 50 | 75 | 104 | 104 CF | 160 CF | | |
| 202135-2 | 201358-1 | 201310-1 | 201345-1 | — | — | Plug Block Receptacle Block | Phenolic |
| 201302-1 | 200277-2 | 201311-1 | 201037-1 | — | — | | |
| 202135-4 | 201358-3 | 201310-3 | 201345-2 | — | — | Plug Block Receptacle Block | |
| 201302-3 | 200277-4 | 201311-3 | — | — | — | | Diallyl Phthalate |
| — | — | — | — | 1-201692-6 | — | Plug Block Receptacle Block | |
| — | — | — | — | — | — | | |
| — | 201443-1Δ | — | — | — | — | 180° Two-Piece Long | Al Anodized Nickel Plated Steel |
| 202383-2 | 201443-2Δ | 202713-2▲ | — | — | — | | |
| — | 200532-1Δ | — | — | — | — | 180° Two-Piece Short | Al Anodized Nickel Plated Steel Nickel Plated Cast Al |
| 202383-1 | 200532-2Δ | 202713-1▲ | — | — | — | | |
| — | — | — | 201131-1Δ | — | — | 90° Two-Piece Long | Nickel Plated Steel |
| — | 203975-2▲ | 202711-3▲ | — | — | — | 90° Two-Piece Short | |
| — | 203975-1▲ | 202711-1▲ | — | — | — | 45° Two-Piece Short | |
| — | — | — | — | — | — | 45° Two-Piece Deep | |
| — | — | — | — | — | — | 180° One-Piece Long | |
| — | — | — | — | — | — | 180° One-Piece Short | |
| — | — | — | — | — | — | 90° One-Piece Short | |
| — | — | — | 201849-3 | — | — | Long Short | Nickel Plated Steel |
| — | 201182-4 | 200730-4 | — | — | — | | |
| 201766-1 | 201847-1 | 201848-5 | — | — | — | Long Short | Stainless Steel |
| — | — | — | — | — | — | | |
| 201092-4 | 201092-4 | 201092-4 | 201092-4 | — | — | Fixed Male | Stainless Steel |
| 201089-4 | 201089-4 | 201089-4 | 201089-4 | — | — | Fixed Female | |
| — | 207234-1▲ | 207234-1▲ | 207234-1▲ | — | — | Long-Long Male | Tip: Stainless Steel Body: Die Cast Zinc |
| — | 207235-1▲ | 207235-1▲ | 207235-1▲ | — | — | Long-Long Female | |
| 201413-4 | 201413-4Δ | 201413-4Δ | 201413-4Δ | — | — | Long Male | |
| 201414-4 | 201414-4Δ | 201414-4Δ | 201414-4Δ | — | — | Long Female | |
| — | — | — | — | — | — | Short-Short Male | |
| — | — | — | — | — | — | Short-Short Female | Stainless Steel |
| — | — | — | — | — | — | Center Male | |
| — | — | — | — | — | — | Center Female | |
| — | 1-200833-1 | 1-201046-2 | 1-201046-2 | — | — | Corner Male | Stainless Steel |
| — | 1-200835-1 | 201047-2 | 201047-2 | — | — | Corner Female | |
| — | — | — | — | — | — | Internal Open End | Nickel Plated Steel |
| — | 202394-2 | 201369-4 | 201364-4 | — | — | Internal Closed End | Nickel Plated Steel |
| — | — | — | — | — | — | External Closed End | Al Iridite |
| — | 201390-5 | 201368-4 | 201346-4 | — | — | External Closed End | Nickel Plated Steel |

Cable-to-Panel

Application

E

Featured Hardware

- Strain Relief Clamps
- Locking Springs
- Pin Hoods
- Guide Hardware



| Component Description | | Number of Positions | | | | |
|---|--|---------------------|----------|----------|----------|------------|
| | | 6 | 14 | 20 | 26 | 34 |
| STANDARD HOUSINGS Pages 44 to 51 | Plug Block Receptacle Block } Phenolic | 202758-1 | 201355-1 | 201356-1 | 201359-1 | 1-201357-1 |
| | | 202757-1 | 201298-1 | 200346-2 | 200512-2 | 200838-2 |
| | Plug Block Receptacle Block } Diallyl Phthalate | 202758-3 | — | 201356-3 | 201359-3 | 201357-3 |
| | | 202757-3 | 201298-3 | 200346-4 | 200512-3 | 200838-3 |
| Plug Block Receptacle Block } Polyester | — | — | — | — | 213800-1 | |
| | — | — | — | — | 213802-1 | |
| STRAIN RELIEF CLAMPS Page 88 | Long Short } Nickel Plated Steel | — | 201843-3 | — | 201845-2 | 201846-5 |
| | | 203432-1 | 200686-4 | — | 201229-5 | — |
| | Long Short } Stainless Steel | — | — | — | — | — |
| | | — | — | 201237-2 | — | 201224-7 |
| GUIDE HARDWARE Page 81 | Center Male | 200389-2 | 200389-2 | 200389-2 | 200389-2 | 200389-2 |
| | Center Female | 200390-9 | 200390-9 | 200390-9 | 200390-9 | 200390-9 |
| | Corner Male | — | — | — | — | 1-200833-1 |
| | Corner Female | — | — | — | — | 1-200835-1 |
| LOCKING SPRINGS¹ Page 80 | Male—Nickel Plated Spring Steel | 201921-1 | 201921-1 | 201921-1 | 201923-1 | 201925-1 |
| | Female—Stainless Steel | 201922-1 | 201922-1 | 201922-1 | — | 201926-1 |
| PIN HOODS Pages 82 and 83 | Internal Open End | 204258-6 | 201363-4 | — | 201785-4 | 201786-4 |
| | Internal Closed End | — | — | — | — | — |
| | External Closed End | — | — | — | — | — |
| | External Closed End | — | — | — | — | — |

¹Each part number contains two locking springs. Order one male and one female for each mated pair of connectors.

Cable-to-Panel (Continued)

1. Confirm that Application E (at left) most closely meets your requirements. (Other applications are shown on pages 10-17 and 20 through 25.)
2. Find the appropriate column for the number of positions required.
3. Select part numbers required for the application listed in the column below the number of positions.
If a part number is not listed for a particular item, it is not available.
If more than one part number is listed for a particular hardware item, choose the one which best fits your application.
4. Dimensional information is available on the indicated pages under description column.
5. Select Contacts: Type II (page 30), Type III+ (pages 31 through 35) or Subminiature Coaxial (pages 40, 41).

Special application housings and posted housings may be substituted for these standard housings. See Special Application and Posted Connectors Sections.

This cable-to-panel application utilizes locking springs, strain relief clamps, a pin hood for pin protection and guide hardware.

The 34 and 50 position connectors can be used with either center or corner guide hardware. If center guide hardware is used, an additional four 4-40 screws, nuts and lockwashers are required to secure the locking springs. Corner guides require four guide pins and four guide sockets for each mated pair of connectors.

| Number of Positions | | | | | | Component Description | | |
|---------------------|------------|----|-----|------------|--------|--|--------------------------------------|---|
| 41 | 50 | 75 | 104 | 104 CF | 160 CF | | | |
| 202135-2 | 201358-1 | — | — | — | — | Plug Block Receptacle Block | Phenolic | STANDARD HOUSINGS Pages 44 to 51 |
| 201302-1 | 200277-2 | — | — | — | — | | | |
| 202135-4 | 201358-3 | — | — | — | — | Plug Block Receptacle Block | Diallyl Phthalate | |
| 201302-3 | 200277-4 | — | — | — | — | | | |
| — | — | — | — | 1-201692-6 | — | Plug Block Receptacle Block | Polyester | |
| — | — | — | — | — | — | | | |
| — | 201182-4 | — | — | — | — | Long Short | Nickel Plated Steel | |
| 201766-1 | 201847-1 | — | — | — | — | | | |
| — | — | — | — | — | — | Long Short | Stainless Steel | |
| 200389-2 | 200389-2 | — | — | — | — | | | |
| 200390-9 | 200390-9 | — | — | — | — | Center Male Center Female Corner Male Corner Female | Stainless Steel | GUIDE HARDWARE Page 81 |
| — | 1-200833-1 | — | — | — | — | | | |
| — | 1-200835-1 | — | — | — | — | | | |
| 201921-1 | 201925-1 | — | — | — | — | | | |
| 201922-1 | 201926-1 | — | — | — | — | Male—Nickel Plated Spring Steel | Locking Springs ¹ | Page 80 |
| — | — | — | — | — | — | Female—Stainless Steel | | |
| — | — | — | — | — | — | Internal Open End | PIN HOODS Pages 82 and 83 | |
| — | — | — | — | — | — | Nickel Plated Steel | | |
| — | — | — | — | — | — | Internal Closed End | | |
| — | — | — | — | — | — | Nickel Plated Steel | | |
| — | — | — | — | — | — | External Closed End | Al Iridite | |
| — | — | — | — | — | — | Nickel Plated Steel | | |

Cable-to-Panel (Continued)

Application

F

Featured Hardware

- Strain Relief Clamps
- Pin Hoods
- Jackscrews
- Guide Hardware



| Component Description | | Number of Positions | | | | | |
|--|--|---|----------|----------|----------|------------|----------|
| | | 6 | 14 | 20 | 26 | 34 | |
| STANDARD HOUSINGS Pages 44 to 51 | Plug Block } Phenolic Receptacle Block | 202758-1 | 201355-1 | 201356-1 | 201359-1 | 1-201357-1 | |
| | | 202757-1 | 201298-1 | 200346-2 | 200512-2 | 200838-2 | |
| | Plug Block } Diallyl Phthalate Receptacle Block | 202758-3 | — | 201356-3 | 201359-3 | 201357-3 | |
| | | 202757-3 | 201298-3 | 200346-4 | 200512-3 | 200838-3 | |
| Plug Block } Polyester Receptacle Block | — | — | — | — | 213800-1 | | |
| | — | — | — | — | 213802-1 | | |
| STRAIN RELIEF CLAMPS Page 88 | Long } Nickel Plated Steel Short | — | 201843-1 | — | 201845-1 | 201846-1 | |
| | | 203432-1 | 200686-1 | — | 201229-1 | — | |
| | Long } Stainless Steel Short | — | — | — | — | — | |
| | | — | — | 201237-1 | — | 201224-1 | |
| JACKSCREWS¹ Pages 78 and 79 | Fixed Male } Stainless Steel | 201092-4 | 201092-4 | 201092-4 | 201092-4 | 201092-4 | |
| | Fixed Female | 201089-4 | 201089-4 | 201089-4 | 201089-4 | 201089-4 | |
| | Long-Long Male } Long-Long Female } Long Male } Long Female } Short-Short Male } Short-Short Female } | Tip: Stainless Steel Body: Die Cast Zinc | — | — | — | — | — |
| | | | — | — | — | — | — |
| | | | — | — | — | — | — |
| | | | 201827-1 | 201827-1 | 201827-1 | 201827-1 | 201827-1 |
| | | | 201828-1 | 201828-1 | 201828-1 | 201828-1 | 201828-1 |
| | | | — | — | — | — | — |
| GUIDE HARDWARE Page 81 | Center Male } Stainless Steel | — | — | — | — | — | |
| | Center Female | — | — | — | — | — | |
| | Corner Male } Stainless Steel | — | — | — | — | 1-200833-1 | |
| | Corner Female | — | — | — | — | 1-200835-1 | |
| PIN HOODS Pages 82 and 83 | Internal Open End } Nickel Plated Steel | 204258-6 | 201363-4 | — | 201785-4 | 201786-4 | |
| | Internal Closed End } Nickel Plated Steel | — | — | — | — | 202434-4 | |
| | External Closed End Al Iridite | — | — | — | 201349-2 | 201350-2 | |
| | External Closed End Nickel Plated Steel | — | — | — | — | — | |

¹Listed Jackscrews have 6-32 single lead threads. For corresponding Jackscrews with 6-32 double lead threads, refer to pages 78 and 79.

Cable-to-Panel (Continued)

1. Confirm that Application F (at left) most closely meets your requirements. (Other applications are shown on pages 10-19 and 22 through 25.)
2. Find the appropriate column for the number of positions required.
3. Select part numbers required for the application listed in the column below the number of positions.
If a part number is not listed for a particular item, it is not available.
If more than one part number is listed for a particular hardware item, choose the one which best fits your application.
4. Dimensional information is available on the indicated pages under description column.
5. Select Contacts: Type II (page 30), Type III+ (pages 31 through 35) or Subminiature Coaxial (pages 40, 41).

Special application housings and posted housings may be substituted for these standard housings. See Special Application and Posted Connectors Sections.

This cable-to-panel application utilizes jackscrews, strain relief clamps and guide hardware. A pin hood is provided for pin protection. Sizes 6, 14, 20, 26, and 41 **do not** use guide hardware for this application.

| Number of Positions | | | | | | Component Description | | |
|---------------------|------------|------------|------------|------------|--------|--|---|---|
| 41 | 50 | 75 | 104 | 104 CF | 160 CF | | | |
| 202135-2 | 201358-1 | 201310-1 | 201345-1 | — | — | Plug Block Receptacle Block | Phenolic | STANDARD HOUSINGS Pages 44 to 51 |
| 201302-1 | 200277-2 | 201311-1 | 201037-1 | — | — | | | |
| 202135-4 | 201358-3 | 201310-3 | 201345-2 | — | — | Plug Block Receptacle Block | Diallyl Phthalate | |
| 201302-3 | 200277-4 | 201311-3 | — | — | — | | | |
| — | — | — | — | 1-201692-6 | — | Plug Block Receptacle Block | Polyester | |
| — | — | — | — | — | — | | | |
| — | — | — | 201849-1 | — | — | Long Short | Nickel Plated Steel | |
| — | 201182-1 | 200730-1 | — | — | — | | | |
| 201766-1 | 201847-1 | 201848-1 | — | — | — | Long Short | Stainless Steel | |
| — | — | — | — | — | — | | | |
| 201092-4 | 201092-4 | 201092-4 | 201092-4 | — | — | Fixed Male Fixed Female | Stainless Steel | |
| 201089-4 | 201089-4 | 201089-4 | 201089-4 | — | — | | | |
| — | — | — | — | — | — | Long-Long Male Long-Long Female Long Male Long Female Short-Short Male Short-Short Female | Tip: Stainless Steel Body: Die Cast Zinc | JACKSCREWS¹ Pages 78 and 79 |
| — | — | — | — | — | — | | | |
| — | — | — | — | — | — | | | |
| — | — | — | — | — | — | | | |
| 201827-1 | 201827-1 | 201827-1 | 201827-1 | — | — | | | |
| 201828-1 | 201828-1 | 201828-1 | 201828-1 | — | — | Center Male Center Female Corner Male Corner Female | Stainless Steel | GUIDE HARDWARE Page 81 |
| — | — | — | — | — | — | | | |
| — | 1-200833-1 | 1-201046-2 | 1-201046-2 | — | — | | | |
| — | 1-200835-1 | 201047-2 | 201047-2 | — | — | Internal Open End Internal Closed End | Nickel Plated Steel | PIN HOODS Pages 82 and 83 |
| — | — | — | — | — | — | | | |
| — | 202394-2 | 201369-4 | 201364-4 | — | — | External Closed End | Al Iridite | |
| — | — | — | — | — | — | | | |
| — | 201390-5 | 201368-4 | 201346-4 | — | — | External Closed End | Nickel Plated Steel | |

Cable-to-Panel (Continued)

Application

G

Featured Hardware

- Shields (One-piece)
- Pin Hoods
- Locking Springs
- Guide Hardware



| Component Description | | Number of Positions | | | | | |
|---|--|---------------------|----------|----------|----------|------------|------------|
| | | 6 | 14 | 20 | 26 | 34 | |
| STANDARD HOUSINGS Pages 44 to 51 | Plug Block Receptacle Block } Phenolic | — | 201355-1 | 201356-1 | 201359-1 | 1-201357-1 | |
| | | — | 201298-1 | 200346-2 | 200512-2 | 200838-2 | |
| | Plug Block Receptacle Block } Diallyl Phthalate | — | — | 201356-3 | 201359-3 | 201357-3 | |
| | | — | 201298-3 | 200346-4 | 200512-3 | 200838-3 | |
| | Plug Block Receptacle Block } Polyester | — | — | — | — | 213800-1 | |
| | | — | — | — | — | 213802-1 | |
| SHIELDS Pages 84 to 87 | 180° Two-Piece Long { | Al Anodized | — | — | — | — | |
| | | Nickel Plated Steel | — | — | — | — | |
| | 180° Two-Piece Short { | Al Anodized | — | — | — | — | |
| | | Nickel Plated Steel | — | — | — | — | |
| | 90° Two-Piece Long } 90° Two-Piece Short } 45° Two-Piece Short } 45° Two-Piece Deep } 180° One-Piece Long } 180° One-Piece Short } 90° One-Piece Short } | Nickel Plated Steel | — | — | — | — | — |
| | | | — | — | — | — | — |
| | | | — | — | — | — | — |
| | | | — | 201378-2 | — | — | 201384-2 |
| | | | — | 201360-2 | 201227-2 | 201169-2 | 201165-2 |
| | | | — | — | — | — | 201469-2 |
| GUIDE HARDWARE Page 81 | Center Male } Center Female } Corner Male } Corner Female } | Stainless Steel | — | 200389-2 | 200389-2 | 200389-2 | 200389-2 |
| | | | — | 200390-9 | 200390-9 | 200390-9 | 200390-9 |
| | | | — | — | — | — | 1-200833-1 |
| | | | — | — | — | — | 1-200835-1 |
| LOCKING SPRINGS¹ Page 80 | Male—Nickel Plated Spring Steel | — | 201921-1 | 201921-1 | 201923-1 | 201925-1 | |
| | Female—Stainless Steel | — | 201922-1 | 201922-1 | — | 201926-1 | |
| PIN HOODS Pages 82 and 83 | Internal Open End Nickel Plated Steel | — | 201363-4 | — | 201785-4 | 201786-4 | |
| | Internal Closed End Nickel Plated Steel | — | — | — | — | — | |
| | External Closed End Al Iridite | — | — | — | — | — | |
| | External Closed End Nickel Plated Steel | — | — | — | — | — | |

¹Each part number contains two locking springs. Order one male and one female for each mated pair of connectors.

Cable-to-Panel (Continued)

- Confirm that Application G (at left) most closely meets your requirements. (Other applications are shown on pages 10-21 and 24, 25.)
- Find the appropriate column for the number of positions required.
- Select part numbers required for the application listed in the column below the number of positions.
If a part number is not listed for a particular item, it is not available.
If more than one part number is listed for a particular hardware item, choose the one which best fits your application.
- Dimensional information is available on the indicated pages under description column.
- Select Contacts: Type II (page 30), Type III+ (pages 31 through 35) or Subminiature Coaxial (pages 40, 41).

Special application housings and posted housings may be substituted for these standard housings. See Special Application and Posted Connectors Sections.

This cable-to-panel application utilizes locking springs, one-piece shields, a pin hood for pin protection and guide hardware. The shields are available with both 180° and 90° cable exits. The 180° shields are available in a long version which provides pin protection in lieu of a pin hood.

Do not select a long shield and a pin hood.

The 34 and 50 position connectors can be used with either center or corner guide hardware. If center guides are used, an additional four 4-40 screws are required to secure the locking springs. If corner guides are used, an additional two 4-40 screws will be required to attach the shield. Corner guides require four guide pins and four guide sockets for each mated pair.

| | | Number of Positions | | | | Component Description | | |
|----------|------------|---------------------|-----|------------|--------|--|---|---|
| 41 | 50 | 75 | 104 | 104 CF | 160 CF | | | |
| 202135-2 | 201358-1 | — | — | — | — | Plug Block Receptacle Block | Phenolic | STANDARD HOUSINGS Pages 44 to 51 |
| 201302-1 | 200277-2 | — | — | — | — | | | |
| 202135-4 | 201358-3 | — | — | — | — | Plug Block Receptacle Block | Diallyl Phthalate | |
| 201302-3 | 200277-4 | — | — | — | — | | | |
| — | — | — | — | 1-201692-6 | — | Plug Block Receptacle Block | Polyester | |
| — | — | — | — | — | — | | | |
| — | — | — | — | — | — | 180° Two- Piece Long | { Al Anodized Nickel Plated Steel | |
| — | — | — | — | — | — | | | |
| — | — | — | — | — | — | 180° Two- Piece Short | { Al Anodized Nickel Plated Steel Nickel Plated Cast Al | |
| — | — | — | — | — | — | | | |
| — | — | — | — | — | — | 90° Two-Piece Long 90° Two-Piece Short 45° Two-Piece Short 45° Two-Piece Deep 180° One-Piece Long 180° One-Piece Short 90° One-Piece Short | Nickel Plated Steel | SHIELDS Pages 84 to 87 |
| — | — | — | — | — | — | | | |
| — | — | — | — | — | — | | | |
| — | — | — | — | — | — | | | |
| — | — | — | — | — | — | | | |
| 200389-2 | 200389-2 | — | — | — | — | Center Male Center Female Corner Male Corner Female | Stainless Steel | GUIDE HARDWARE Page 81 |
| 200390-9 | 200390-9 | — | — | — | — | | | |
| — | 1-200833-1 | — | — | — | — | | | |
| — | 1-200835-1 | — | — | — | — | | | |
| 201921-1 | 201925-1 | — | — | — | — | Male—Nickel Plated Spring Steel | | LOCKING SPRINGS¹ Page 80 |
| 201922-1 | 201926-1 | — | — | — | — | Female—Stainless Steel | | |
| — | — | — | — | — | — | Internal Open End | Nickel Plated Steel | PIN HOODS Pages 82 and 83 |
| — | — | — | — | — | — | Internal Closed End | Nickel Plated Steel | |
| — | — | — | — | — | — | External Closed End | Al Iridite | |
| — | — | — | — | — | — | External Closed End | Nickel Plated Steel | |

Cable-to-Panel (Continued)

Application

H

Featured Hardware

- Shields (Two-piece)
- Pin Hoods
- Guide Hardware
- Jackscrews



| Component Description | Number of Positions | | | | | | |
|--|--|---------------------------|----|----------|----------|------------|------------|
| | 6 | 14 | 20 | 26 | 34 | | |
| STANDARD HOUSINGS Pages 44 to 51 | Plug Block Receptacle Block } Phenolic | — | — | 201356-1 | 201359-1 | 1-201357-1 | |
| | | — | — | 200346-2 | 200512-2 | 200838-2 | |
| | Plug Block Receptacle Block } Diallyl Phthalate | — | — | 201356-3 | 201359-3 | 201357-3 | |
| | | — | — | 200346-4 | 200512-3 | 200838-3 | |
| SHIELDS Pages 84 to 87 | Plug Block Receptacle Block } Polyester | — | — | — | — | 213800-1 | |
| | | — | — | — | — | 213802-1 | |
| | 180° Two-Piece Long { | Al Anodized | — | — | — | 201576-1 | 201571-1 |
| | | Nickel Plated Steel | — | — | — | 201576-2 | 201571-2 |
| | 180° Two-Piece Short { | Al Anodized | — | — | — | — | 200517-1 |
| | | Nickel Plated Steel | — | — | 204087-1 | 200514-2 | 200517-9 |
| | 90° One-Piece Long 90° Two-Piece Short 45° Two-Piece Short 45° Two-Piece Deep 180° One-Piece Long 180° One-Piece Short 90° One-Piece Short | Nickel Plated Steel | — | — | — | — | — |
| | | | — | — | — | — | — |
| | | | — | — | — | — | — |
| | | | — | — | — | — | — |
| — | | | — | — | — | — | |
| — | | | — | — | — | — | |
| JACKSCREWS¹ Pages 78 and 79 | Fixed Male Fixed Female } Stainless Steel | — | — | 201092-4 | 201092-4 | 201092-4 | |
| | | — | — | 201089-4 | 201089-4 | 201089-4 | |
| | Long-Long Male Long-Long Female Long Male Long Female Short-Short Male Short-Short Female } Tip: Stainless Steel Body: Die Cast Zinc | — | — | — | — | — | |
| | | — | — | — | — | — | |
| | | — | — | 201413-4 | 201413-4 | 201413-4 | |
| | | — | — | 201414-4 | 201414-4 | 201414-4 | |
| GUIDE HARDWARE Page 81 | Stainless Steel | Center Male | — | — | — | — | |
| | | Center Female | — | — | — | — | |
| | | Corner Male | — | — | — | — | 1-200833-1 |
| | | Corner Female | — | — | — | — | 1-200835-1 |
| PIN HOODS Pages 82 and 83 | Internal Open End | Nickel Plated Steel | — | — | — | 201786-4 | |
| | Internal Closed End | Nickel Plated Steel | — | — | — | 202434-4 | |
| | External Closed End | Al Iridite | — | — | — | 201350-2 | |
| | External Closed End | Nickel Plated Steel | — | — | — | — | |

¹Listed Jackscrews have 6-32 single lead threads. For corresponding Jackscrews with 6-32 double lead threads, refer to pages 78 and 79.

Cable-to-Panel (Continued)

1. Confirm that Application H (at left) most closely meets your requirements. (Other applications are shown on pages 10 through 23.)
2. Find the appropriate column for the number of positions required.
3. Select part numbers required for the application listed in the column below the number of positions.
If a part number is not listed for a particular item, it is not available.
If more than one part number is listed for a particular hardware item, choose the one which best fits your application.
4. Dimensional information is available on the indicated pages under description column.
5. Select Contacts: Type II (page 30), Type III+ (pages 31 through 35) or Subminiature Coaxial (pages 40, 41).

Special application housings and posted housings may be substituted for these standard housings. See Special Application and Posted Connectors Sections.

This cable-to-panel application utilizes jackscrews, a two-piece short shield, a strain relief clamp, a pin hood for pin protection and guide hardware.

Do not use a pin hood in combination with the shield for sizes 20, 26 and 41. A long shield may be used in lieu of pin hood for pin protection for all sizes except the 20 position. Shields are available with 180° cable exit and for the 50 thru 104 position connectors, a 90° cable exit. 104 CF has 90° and 45° cable exits. 160 CF has 45° cable exit.

Select the appropriate jackscrew length for the type of shield chosen as indicated by symbol (Δ▲).

| Number of Positions | | | | | | Component Description | |
|---------------------|------------|------------|------------|------------|------------|-----------------------|---|
| 41 | 50 | 75 | 104 | 104 CF | 160 CF | | |
| 202135-2 | 201358-1 | 201310-1 | 201345-1 | 201692-4 | 202799-2 | Plug Block | Phenolic |
| 201302-1 | 200277-2 | 201311-1 | 201037-1 | 201532-4 | 202800-2 | Receptacle Block | |
| 202135-4 | 201358-3 | 201310-3 | 201345-2 | 201692-3 | 202799-1 | Plug Block | Diallyl Phthalate |
| 201302-3 | 200277-4 | 201311-3 | — | 201532-2 | 202800-1 | Receptacle Block | |
| — | — | — | — | 1-201692-6 | — | Plug Block | Polyester |
| — | — | — | — | — | — | Receptacle Block | |
| — | 201443-1Δ | — | — | — | — | 180° Two-Piece Long | Al Anodized Nickel Plated Steel |
| 202383-2 | 201443-2Δ | 202713-2▲ | — | — | — | — | |
| — | 200532-1Δ | — | — | — | — | — | Al Anodized Nickel Plated Steel Nickel Plated Cast Al |
| 202383-1 | 200532-2Δ | 202713-1▲ | — | — | — | 180° Two-Piece Short | |
| — | — | — | 201131-1Δ | — | — | — | Nickel Plated Steel |
| — | 203975-2▲ | 202711-3▲ | — | — | — | 90° Two-Piece Long | |
| — | 203975-1▲ | 202711-1▲ | — | 202395-1 | — | 90° Two-Piece Short | SHIELDS Pages 84 to 87 |
| — | — | — | — | 202110-1 | 202798-1 | 45° Two-Piece Short | |
| — | — | — | — | 202169-1 | — | 45° Two-Piece Deep | Nickel Plated Steel |
| — | — | — | — | — | — | 180° One-Piece Long | |
| — | — | — | — | — | — | 180° One-Piece Short | Nickel Plated Steel |
| — | — | — | — | — | — | 90° One-Piece Short | |
| 201092-4 | 201092-4 | 201092-4 | 201092-4 | — | — | Fixed Male | Stainless Steel |
| 201089-4 | 201089-4 | 201089-4 | 201089-4 | — | — | Fixed Female | |
| — | 207234-1▲ | 207234-1▲ | 207234-1▲ | — | — | Long-Long Male | Tip: Stainless Steel |
| — | 207235-1▲ | 207235-1▲ | 207235-1▲ | — | — | Long-Long Female | |
| 201413-4 | 201413-4Δ | 201413-4Δ | 201413-4Δ | — | — | Long Male | Body: Die Cast Zinc |
| 201414-4 | 201414-4Δ | 201414-4Δ | 201414-4Δ | — | — | Long Female | |
| — | — | — | — | — | — | Short-Short Male | Stainless Steel |
| — | — | — | — | — | — | Short-Short Female | |
| — | — | — | — | — | — | Center Male | GUIDE HARDWARE Page 81 |
| — | — | — | — | — | — | Center Female | |
| — | 1-200833-1 | 1-201046-2 | 1-201046-2 | 202173-8 | 1-201046-2 | Corner Male | Stainless Steel |
| — | 1-200835-1 | 201047-2 | 201047-2 | 202174-5 | 201047-2 | Corner Female | |
| — | — | — | — | — | — | Internal Open End | Nickel Plated Steel |
| — | 202394-2 | 201369-4 | 201364-4 | — | 203743-4 | Internal Closed End | Nickel Plated Steel |
| — | — | — | — | — | — | External Closed End | Al Iridite |
| — | 201390-5 | 201368-4 | 201346-4 | 202119-2 | 203744-4 | External Closed End | Nickel Plated Steel |

Singal Contacts

Type III+, Crimp, Snap-In, Size 16

Precision formed pin and socket contacts in Size 16. They are used in M Series, Special M Series, "G" Series, Metrimate, Metrimate Drawer, and CPC Series 1 and 4 connectors. Contacts feature a high normal force which provides a low resistance in significant applications such as dry circuit signal conditions. Mating entry is closed-ended to prevent damage from stubbing due to misalignment. Stainless steel spring provides superior normal force and retention in the housing. AMP proprietary gold plating process is designed so that specified plating thicknesses are controlled on the inside of the socket, which is the critical contact mating area. The contacts are formed from brass. Single contact rating is 13 amperes at 30°C T-Rise. The single contact rating for enhanced high current Type III+ is 24 amperes @ 30°C T-Rise.

See page 31 for product details.

Type III+, Solder Type, Size 16

As with the crimp snap-in Type III+, these precision formed solder-type contacts are also used in M Series, Special M Series, Metrimate, Metrimate Drawer, and CPC Series 1 and 4 connectors. Contacts feature a high normal force which provides a low resistance in significant applications, such as dry circuit conditions. A preformed wire barrel accepts both stranded and solid wire, while the preformed insulation barrel provides strain relief for various wire insulation thicknesses. Mating entry is closed-ended to prevent damage from stubbing due to misalignment. A stainless steel spring provides superior normal force and retention in the housing. AMP proprietary gold plating process is designed so that specified plating thicknesses are controlled on the inside of the socket, which is the critical contact area. Single contact current rating is 13 amperes at 30°C Temperature Rise. Single contact rating for enhanced high current Type III+ is 24 amperes at 30°C T-Rise.

See pages 34 and 35 for product details.

Type III+, Solder Tab, Size 16

A companion contact style to the crimp snap-in and solder-type, the Type III+ Solder Tab is compatible with the same AMP connector families, and features high normal forces to provide a low resistance in significant applications. A pre-crimped solder tab with slot accepts various sizes of solid and stranded wire. Mating entry is closed-ended to prevent stubbing due to misalignment. A stainless steel spring provides superior normal force and retention in the housing. AMP proprietary gold plating process is designed so that specified plating thicknesses are controlled on the inside of the socket, which is the critical contact area. Single contact current rating is 13 amperes at 30°C Temperature Rise.

See page 35 for product details.

Signal Contacts (Continued)

Type III+, Posted Version, Size 16

The last member of the Type III+ family of contacts, the posted version is compatible with M Series, Special M Series, Metrimate, Metrimate Drawer, and CPC Series 1 connectors. Precision formed, they are pre-crimped to various post configurations including those that accept TERMI-POINT Clip or wire-wrap type terminations. Contacts feature high normal force which provides a low resistance in significant applications. Mating entry is closed-ended to prevent damage from stubbing due to misalignment. A stainless steel spring provides superior normal force and retention in the housing. AMP proprietary gold plating process is designed so that specified plating thicknesses are controlled on the inside of the socket, which is the critical contact mating area. Contacts are formed from brass. Single contact current rating is 13 amperes at 30°C Temperature Rise.

See page 32 for product details.

Type II, Crimp, Snap-In, Size 16

Precision screw-machined pin and socket contacts, they are used in M Series, Special M Series, "G" Series, Metrimate, Metrimate Drawer, and CPC Series 1 and 4 connectors. Contacts feature high normal force which provides a low resistance in significant applications such as dry circuit signal conditions. Mating entry is closed-ended to prevent damage from stubbing due to misalignment. A stainless steel spring provides superior normal force and retention in the housing. The contact bodies are machined from solid brass. Single contact current rating is 13 amperes at 30°C Temperature Rise.

See page 30 for product details.

Power Contacts

Type I, Crimp, Snap-In, Size 12

Precision screw-machined pin and socket, Size 12 contacts, they are used in Special M Series and "G" Series connectors, and are inserted into the same cavities as Miniature Coaxial contacts. These contacts feature a high normal force which provides a low resistance in significant applications. Mating entry is closed-ended to prevent damage from stubbing due to misalignment. Beryllium copper springs are used to provide contact normal force and are assisted by a stainless steel hood which provides anti-overstress assurance. Single contact current rating is 23 amperes at 30°C Temperature Rise.

See page 36 for product details.

Type XII, Crimp-Type

Precision formed male and female contacts used in CPC Series 3 and 4, Special M Series and "G" Series connectors, these contacts offer a low cost power option which provides additional applied cost savings when terminated with semiautomatic application equipment. The contact body is made from 100% copper, which provides for excellent conductivity. Spring characteristics are derived from a captive stainless steel spring which assists the dual cantilever spring members of the female contact. Single contact current rating is 35 amperes at 30°C Temperature Rise.

See page 38 for product details.

High Current Upgrades

Precision screw-machined pin and socket contacts have increased current capability. All upgraded contacts use the high amperage Louvertac contact band. The design of this contact allows for increased current in the same form factor. For example, Type II/Type III+ upgraded contacts increase the current from 13 amperes free air to 23 amperes free air at a 30°C Temperature Rise.

See pages 37 and 39 for product details.

Coaxial Contacts

Subminiature, Crimp, Snap-In, Size 16

Precision screw-machined pin and socket, Size 16 contacts, they are used in M Series, Special M Series, and CPC Series 1 and 4. They provide cost effective solutions in applications where mixtures of signal, power, and coaxial cable terminations are desired. The contact outer shell is made from brass, while the center pin conductor is beryllium copper, and the socket is brass. Both the pin and socket center conductor are gold plated for maximum corrosion resistance and minimum contact resistance. The retention spring is stainless steel, while the ferrule is tin plated copper. Contact design offers application of coaxial cable, shielded conductors, and twisted pair wire with a voltage rating of up to 200 VRMS, and a current rating of 1.0 ampere at 30°C Temperature Rise.

See pages 40 and 41 for product details.

Miniature, Crimp, Snap-In, Size 12

Precision screw-machined, Size 12 pin and socket contacts, they are used in Special M Series and "G" Series connectors. They provide cost effective solutions in applications where a mixture of signal, power, and coaxial cable terminations is desirable. Contact body and center wire conductor are made from brass, and are gold plated for maximum corrosion resistance and minimum contact resistance. The retention spring is beryllium copper, and the ferrule is tin plated copper. Contact design offers application of coaxial cable, shielded conductors, and twisted pair wire with a voltage rating of up to 325 VRMS, and a current rating of 7.5 amperes at 30°C Temperature Rise.

See pages 42 and 43 for product details.

Singal Contacts (Continued)

**Type II, Screw Machine,
Crimp**

Material

Contact Body - Brass

Retention Spring -
Stainless steel

Finish

Contact Body -

.000030 [0.00076] gold over

.000050 [0.00127] nickel.

Gold thickness controlled
on socket O.D.

Retention Spring -

Stainless steel

Related Product Data

Application Tooling -

Pages 76-79



Contact Size 16—Pin Diameter .062 [1.57] (Test Current, 13 Ampere)†

| Wire Size Range | Ins. Dia. Range ¹ | Tape Mounted Contact No. ² | | Loose Piece Contact No. | | Contact Color Code | Tooling Part No. | | | | | |
|--------------------|------------------------------------|--|-----------------------|----------------------------|-------------------------|--------------------------|---|---------|----------------------|--------------------------------------|----------------------|------------------------------------|
| | | Pin | Socket | Pin | Socket | | Tape Mounted | | Hand Tool | | | |
| | | | | | | | Dies for AMP-TAPETRONIC Machine 69875 | | | Dies for Pneumatic Tool System | | |
| 28-24 | 0.08-0.20 | 0.035-.055 0.89-1.40 | 201611-4 | — | 201611-1 ⁴ | 201613-1 ⁵ | Red/Red | 90249-2 | 90230-1 ⁷ | 91538-1 or 601967-1 | | |
| | | | — | — | 201334-1 ⁴ | 201332-1 ⁵ | | | — | 601967-1 | | |
| | | | — | — | 202410-1 ⁴ | 202411-1 ⁵ | | | | | Green | |
| 24-20 | 0.2-0.6 | .040-.062 1.02-1.57 | 201578-4 | — | 201578-1 ⁴ | 201580-1 ⁵ | Yellow/Red | 90249-2 | 90230-1 ⁷ | 91538-1 or 58541-1* | | |
| | | | 201330-6 | 201328-9 | 201330-1 ⁴ | 201328-1 ⁵ | | | Yellow/Red | or 601967-1 | | |
| | | | — | — | 202725-1 ⁴ | 202726-1 ⁴ | | | | | Blue | — |
| 18 (Two) | 0.9-0.9 (Two) | No. Ins. Support | — | — | 202725-1 ⁴ | 202726-1 ⁴ | Blue | — | 90231-2 ⁷ | 91539-1 or 601967-1 | | |
| 18-16 | 0.8-1.4 | .080-.105 2.03-2.67 | — | — | 202507-1 ⁴ | 202508-1 ⁵ | | | — | — | — | 90136-1 or 601967-1 |
| | | | 200336-6 | 200333-8 | 200336-1 ⁴ | 200333-1 ⁴ | Blue/Blue | 90250-1 | | | 90231-2 ⁷ | 91539-1 58541-1* or 601967-1 |
| | | | — | — | 204219-1 ^{5,6} | — | | | | | | |
| 14 | 2 | No. Ins. Support | 212618-2 ³ | 201568-3 | 201570-1 ⁴ | 201568-1 ⁵ | Violet/Blue | 90250-1 | 90231-2 ⁷ | 91539-1 58541-1* or 601967-1 | | |
| — | — | 201570-2 | — | 212618-1 ^{3,6,†} | — | — | | | | | — | |

¹Overall insulation crimp diameter, including crimp barrel, must not exceed .125 [3.18].

²For AMP-TAPETRONIC Machine No. 69875, order contacts by Tape Mounted Contact No., plus packaging code "IM REEL" (5000 parts per reel).

³Grounding pin is used to provide a make-first/break-last condition when mating and unmating connector halves.

⁴Use turret TH502 (1-601967-6) with hand tool 601967-1.

⁵Use turret TH501 (1-601967-5) with hand tool 601967-1.

⁶Pin length is .630 ± 0.005 [16.002 ± 0.127] on these two pins.

⁷Die Set requires "C" Head Adapter Part No. 318161-1; Adapter Holder Part No. 356304-1 (with ratchet) or 189928-1 (without); and Power Unit Part No. 189721-2 (hand actuated) or 189722-2 (foot actuated).

*Commercial PRO-CRIMPER II Hand Tool for field repair use only. Note: Die Set can be adapted for use with the 626 Pneumatic Tool System.

† Does not use Hand Tool 91539-1 or 601967-1.

‡ Single contact, free-air test current is not to be construed as contact rating current. Use only for testing. Refer to contact current carrying capability information on page 8.

Insertion Tool Part No. 200893-2 (for insulation diameters .070 [1.78] or less).

Extraction Tool Part No. 305183

Signal Contacts (Continued)

Type III+, Crimp, Snap-In

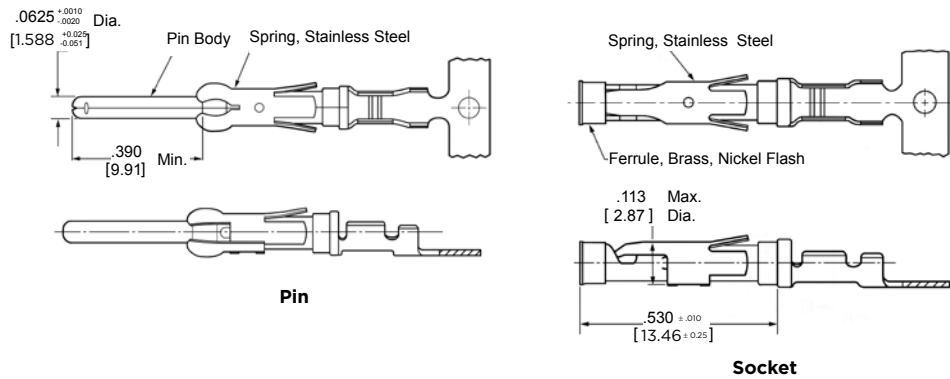

Related Product Data

Application Tooling - Pages 76-79

Technical Documents

114-10004 application Specification
108-10024 Product Specification

Material and Finish - See chart
Contact Body - Brass or phospher bronze⁷
Retention Spring - Stainless steel

**Contact Size 16 - Pin Diameter .062 [1.57]
(Test Current, 13 Ampere)†**

† Single contact, free-air test current is not to be construed as contact rating current. Use only for testing. Refer to contact current carrying capability information on page 8.

| AWG | Wire Size Range mm ² | Ins. Dia. Range | Contact Finish | Strip Form Contact No. | | Loose Piece Contact No. | | Tooling Part No. | | | |
|-------|------------------------------------|-------------------------------------|-------------------------------|------------------------|------------------------|-------------------------|----------------------|-----------------------|---|----------------------|----------------------------------|
| | | | | Pin | Socket | Pin | Socket | Loose Piece Hand Tool | Strip Form Applicators | | |
| 30-28 | 0.05-0.09 | .015-.030 0.38-0.76 | Gold/Nickel ² | 788085-3 | 788088-2 | — | — | 90716-1 | 567867-1*** or 567947-1*** or 680602-□*** | | |
| | | | Sel. Gold/Nickel ³ | 788085-1 | 788088-1 | 788085-4 | 788088-3 | | — | — | |
| | | | Bright Tin | 1-66425-2 | 1-66424-1 | — | — | | — | — | |
| 30-26 | 0.05-0.15 | .040-.060 ¹ 1.02-1.52 | Gold/Nickel ² | 66425-7 | 66424-7 | 66429-3 | 66428-3 | 91515-1 ⁶ | 466598-□*** | | |
| | | | Sel. Gold/Nickel ³ | 66425-8 | 66424-8 | 66429-4 | 66428-4 | | | — | — |
| | | | Gold/Nickel ² | 66393-7 | 66394-7 | — | — | | | — | — |
| 26-24 | 0.12-0.2 | .035-.055 ¹ 0.89-1.40 | Sel. Gold/Nickel ³ | 66393-8 | 66394-8 | 66406-4 | 66405-4 | 90225-2 ⁶ | 466585-3*** | | |
| | | | Bright Tin | 1-66106-5 | 1-66108-5 | 1-66107-1 | 1-66109-7 | | | — | — |
| | | | Gold/Nickel ² | 66106-7 | 66108-7 | 66107-3 | 66109-3 | | | 91515-1 ⁶ | 466321-□*** or 466908-2*** |
| 24-20 | 0.2-0.6 | .040-.080 ¹ 1.02-2.03 | Sel. Gold/Nickel ³ | 66106-8 | 66108-8 | 66107-4 | 66109-4 | 58495-1* | 466908-2*** | | |
| | | | Gold/Nickel ² | 66102-8 | 66104-8 | 66103-3 | 66105-3 | | | 91515-1 ⁶ | 466323-□*** or 466907-2*** |
| | | | Sel. Gold/Nickel ³ | 66102-9 | 66104-9 | 66103-4 | 66105-4 | | | — | — |
| 24-20 | 0.2-0.6 | .060-.120 ⁵ 1.52-3.05 | Sel. Gold/Nickel ⁴ | — | 66104-1 | — | 66105-1 | 91542-1 ⁶ | 466383-4*** or 466979-1*** or 567363-□*** | | |
| | | | Bright Tin | 1-66564-2 | 1-66563-1 | 66566-7 | 66565-7 | | | — | — |
| | | | Gold/Nickel ² | 66564-8 | 66563-8 | 66566-4 | 66565-4 | | | — | — |
| 18-16 | 0.8-1.4 | .080-.100 ¹ 2.03-2.54 | Bright Tin | 1-66332-4 | 1-66331-4 | 1-66400-0 | 1-66399-0 | 91523-1 ⁶ | 466324-□*** or 466942-1*** | | |
| | | | Gold/Nickel ² | 66332-7 | 66331-7 | 66400-3 | 66399-3 | | | 90225-2 ⁶ | 466942-1*** |
| | | | Sel. Gold/Nickel ³ | 66332-8 | 66331-8 | 66400-4 | 66399-4 | | | — | — |
| 18-14 | 0.8-2.0 | .080-.100 ¹ 2.03-2.54 | Sel. Gold/Nickel ⁴ | — | 66331-2 | — | 66399-2 | 91519-1 ⁶ | 466326-□*** or 466923-2*** | | |
| | | | Bright Tin | 1-66359-4 | 1-66358-6 | 1-66361-2 | 1-66360-2 | | | — | — |
| | | | Gold/Nickel ² | 66359-9 | 66358-9 | 66361-3 | 66360-3 | | | — | — |
| 18-14 | 0.8-2.0 | .110-.150 ⁵ 2.79-3.81 | Sel. Gold/Nickel ³ | 1-66359-0 | 1-66358-0 | 66361-4 | 66360-4 | 91521-1 ⁶ | 466958-1*** or 567364-□*** | | |
| | | | Gold/Nickel ² | 1-66359-2 ⁷ | 1-66358-3 ⁷ | 66361-8 ⁷ | 66360-8 ⁷ | | | — | — |
| | | | Bright Tin | 66597-8 | 66598-9 | 66602-8 | 66601-9 | | | — | — |
| | | | Sel. Gold/Nickel ³ | 66597-2 | 66598-2 | 66602-2 | 66601-2 | | | | |

¹ Overall insulation crimp diameter, including crimp barrel, must not exceed .125 [3.18].
² .000015 [0.00038] gold in the mating area over .000050 [0.00127] min. nickel.
³ .000030 [0.00076] gold in the mating area, with gold flash on remainder, over .000050 [0.00127] min. nickel.
⁴ .000030 [0.00076] gold in the mating area, with gold gradient on remainder, over .000050 [0.00127] min. nickel.
⁵ Phosphor bronze contact body

⁶ Contacts can ONLY be used in: Metrimate; CPC Series 1 (Arr. 23-24), Series 4 (Arr. 23-13M, 23-16M, 23-22M), and VDE connectors.
⁷ To use with the 626 Pneumatic Tool, remove crimping head from Straight Action Hand Tool (SAHT), order SAHT Adapter Part No. 217201-1. Adapter Holder Part No. 356304-1 (with ratchet) or 189928-1 (without), and Power Unit Part No. 189721-1 (hand actuated) or 189722-1 (foot actuated).

⁸ Standard reeling of strip form contacts.
⁹ Commercial PRO-CRIMPER II hand tool for field repair only. Note: Die Set can be adapted for use with 626 Pneumatic Tool System. Insertion Tool Part No. 91002-1 (for insulation diameters .070 [1.78] or less). No. 200893-2 (for insulation diameters .090 [2.29] max.). Extraction Tool Part No. 305183. (Instruction Sheet 408-1216)
*** Call Technical Support for Machine Applicator Part Numbers.

Singal Contacts (Continued)

Type III+, Posted
(Replacement Contacts,
See Note Below)



Pin



Socket



Pin



Socket



Material

Contact Body and Post—Brass

Retention Spring—Stainless steel

Finish

See chart.

Contact Size 16—Pin Diameter .062 [1.57] (Test Current, 13 Ampere)†

| Termination Method | Post Configuration | Contact Finish | Loose Piece Contact No. | | | | | |
|--------------------|-----------------------------------|-------------------------------|-------------------------|-----------|-------------------------|-----------|-------------------------|-----------|
| | | | 3 Termination High Post | | 2 Termination High Post | | 1 Termination High Post | |
| | | | Pin | Socket | Pin | Socket | Pin | Socket |
| Wrap-Type | .025 x .025 0.64 x 0.64 | Sel. Gold/Nickel ¹ | 66460-9 | 66461-9 | 66460-8 | 66461-8 | 66460-7 | 66461-7 |
| | | Gold/Nickel ² | 66460-6 | 66461-6 | — | 66461-5 | 66460-4 | 66461-4 |
| | | Bright Tin | 6-66460-6 | 5-66461-9 | 6-66460-7 | 5-66461-8 | 6-66460-5 | 5-66461-4 |
| | .045 x .045 1.14 x 1.14 | Sel. Gold/Nickel ¹ | 66471-9 | 66473-9 | — | — | 66471-7 | 66473-7 |
| Bright Tin | | 1-66471-7 | 1-66473-8 | — | — | 1-66471-6 | 1-66473-7 | |
| TERMI-POINT Clip | .031 x .062 0.79 x 1.57 | Sel. Gold/Nickel ¹ | 66470-9 | — | — | — | 66470-7 | — |
| | | Sel. Gold/Nickel ¹ | 66468-9 | 66459-9 | — | — | — | — |

¹Gold flash over .000050 [0.00127] nickel on entire contact, with .000030 [0.00076] gold to a distance of .200 [5.08] from mating end. Gold thickness controlled on socket O.D.

².000030 [0.00076] gold over .000050 [0.00127] nickel on contact body. Gold thickness controlled on socket O.D.

Posts plated tin over copper.

Extraction Tool **Part No. 305183** (Instruction Sheet 408-1216)

Insertion Tool **Part No. 200893-2**

Note: These contacts are used as replacement contacts for all posted connectors.

† Single contact, free-air test current is not to be construed as contact rating current. Use only for testing. Refer to contact current carrying capability information on page 7.

Signal Contacts (Continued)

Enhanced High Current Type III+, Crimp, Snap-In

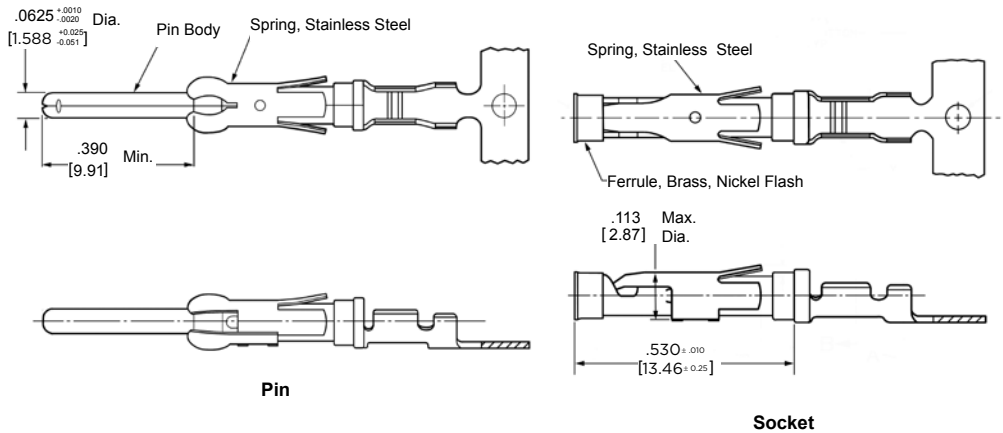

Material and Finish - See chart
Contact Body - Copper Nickel Alloy
Retention Spring - Stainless steel

Related Product Data
Application Tooling - Pages 76-79
Technical Documents
 114-10004 application Specification
 108-10024-2 Product Specification

Contact Size 16—Pin Diameter .062 [1.57]

| Wire Size Range | | Ins. Dia. Range | Contact Finish | Strip Form Contact No. | | Loose Piece Contact No. | | Tooling Part No. | |
|-----------------|-----------------|-------------------------------------|----------------|------------------------|-----------|-------------------------|-----------|-----------------------|---------------------------------|
| AWG | mm ² | | | Pin | Socket | Pin | Socket | Loose Piece Hand Tool | Strip Form Applicators |
| 18-14 | 0.8-2.0 | .080-.100 ¹ 2.03-2.54 | Gold | 1-66359-6 | 1-66358-9 | 1-66361-4 | 1-66360-4 | 91519-1 ³ | 466326□*** or 466923-2*** |
| | | | Tin | 1-66359-9 | 2-66358-1 | 1-66361-6 | 1-66360-6 | | 466958-1*** or 567364□*** |
| | | .110-.150 ² 2.79-3.81 | Gold | 1-66597-0 | 1-66598-1 | 66602-9 | 1-66601-0 | 91521-1 ³ | 466958-1*** or 567364□*** |
| | | | Tin | 1-66597-1 | 1-66598-2 | 1-66602-0 | 1-66601-2 | | |

¹ Overall insulation crimp diameter, including crimp barrel, must not exceed .125 [3.18].
² Contacts can ONLY be used in CPC, Series 1 (Arr. 23-24), Series 4 (Arr. 23-13M, 23-16M, 23-22M), and VDE connectors.
³ To use with the 626 Pneumatic Tool System: remove the crimping head from the Straight Action Hand Tool (SAHT) Assembly, order SAHT Adapter Part No. 217201-1, Adapter Holder Part No. 356304-1 (with ratchet) or 189928-1 (without), and Power Unit Part No. 189721-1 (hand actuated) or 189722-1 (foot actuated).
 *** Call Technical Support for Automatic Machine Applicator Part Numbers.

Ratings

Base Current: Type III+ contacts: 13 amperes, 30°C temperature rise with single contact on 14 AWG wire in free air
Enhanced High Current Type III+ contacts: **24 amperes**, 30°C temperature rise with single contact on 14 AWG wire
Temperature: -55°C to +105°C

Singal Contacts (Continued)

Type III+ (Precision Formed, Crimp)

Grounding Pin
(make first - break last)

Contact Size - 6
Pin Diameter - .062 [1.57]

Material and Finish

Contact Body - Copper alloy, plated tin or gold

Spring - Stainless steel

Related Product Data

Performance Characteristics -

Page 6

Application Tooling - Pages 76-79

Technical Documents - Page 80



| Wire Size Range | | Ins. Dia. Range ¹ | Contact Finish | Grounding Pin Part No. | | Strip Form Applicator Part No. | Loose Piece Hand Tool [□] Part No. |
|-----------------|-------|------------------------------|-------------------------------|------------------------|-------------|--------------------------------|---|
| mm2 | AWG | | | Strip Form | Loose Piece | | |
| 0.12-0.2 | 26-24 | .035-.055 | Tin | 164159-3 | 164162-1 | — | 91515-1 ⁵ or 58495-1* |
| | | | Sel. Gold/Nickel ⁴ | 164159-4 | 164162-2 | | |
| 0.2-0.6 | 24-20 | .045-.070 | Bright Tin | 164160-3 | 164163-1 | 466323-□*** | 91515-1 ⁵ or 58495-1* |
| | | | Sel. Gold/Nickel ⁴ | 164160-4 | 164163-2 | 466907-2*** | 91505-1 ⁵ or 58495-1* |
| 0.8-1.4 | 18-16 | .078-.098 | Tin | 164161-3 | 164164-1 | 466741-□*** | 91523-1 ⁵ or 58495-1* |
| | | | Sel. Gold/Nickel ⁴ | 164161-4 | 164164-2 | 680114-3*** | 91505-1 ⁵ or 58495-1* |

¹Overall insulation crimp diameter, including crimp barrel, must not exceed .125 [3.18].

⁴Gold flash over .000030 [0.00076] min. nickel on entire contact, with .000030 [0.00076] gold in contact area.

⁵To use with the 626 Pneumatic Tool System: remove the crimping head from the Straight Action Hand Tool (SAHT) Assembly, order SAHT Adapter **Part No. 217201-1**, Adapter Holder **Part No. 356304-1** (with ratchet) or **189928-1** (without), and Power Unit **Part No. 189721-1** (hand actuated) or **189722-1** (foot actuated).

*Commercial PRO-CRIMPER II hand tool for field repair only. **Note:** Die Set can be adapted for use with the 626 Pneumatic Tool System.

***Call Technical Support for Automatic Machine Applicator Part Numbers.

Extraction Tool Part No. 539972-1.

High Current Power Contact—Size 16

The features of the High Current Size 16 contact have been designed to retrofit into the existing AMP Connectors such as CPC (Circular Plastic Connector), CMC (Circular Metal Connector), G Series, M Series, Metrimate Square Grid and Drawer Connector housings. An initial T-Rise test in free air has shown a 23 amp capability with a 30° T-Rise. The contact may be crimped onto 14 AWG wire with an AMP hand tool **Part No. 601967-1**. Use turret TH502 (**1-601967-6**) for the pin and turret TH501 (**1-601967-5**) for the socket.

Material

Body - Copper alloy
Louvertac Band - Beryllium copper
Retention Spring - Stainless steel

Finish

Body - Silver
Louvertac Band - Gold



| Wire Range | | Contact Part Nos. | | | | Crimping Tool | | |
|------------|-------|-------------------|--------------|-------------|--------------|---------------|------------|-------------|
| mm2 | AWG | Pin | | Socket | | Tool | Turret | |
| | | Loose Piece | Tape Mounted | Loose Piece | Tape Mounted | | for Pins | for Sockets |
| 0.8-1.4 | 18-16 | 796964-1 | 796964-2 | 796966-1 | 796966-2 | 601967-1 | 1-601967-6 | 1-601967-5 |
| 2 | 14 | 193844-1 | 193844-2 | 193846-1 | 193846-2 | 601967-1 | 1-601967-6 | 1-601967-5 |

Extraction Tool Part No. 305183

Signal Contacts (Continued)

Type III+ (Precision Formed, Solder)

Contact Size - 16
Pin Diameter - .062 [1.57]

Material and Finish

Contact Body - Copper alloy, plated tin to gold

Spring - Stainless steel

Related Product Data

Performance Characteristics -

Page 6

Technical Documents - Page 80

Solder-Type

(with Preformed Wire Barrel/Insulation Support)

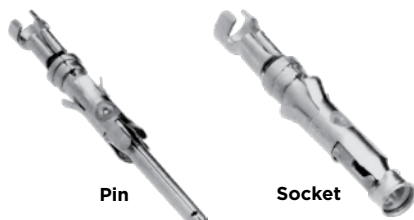
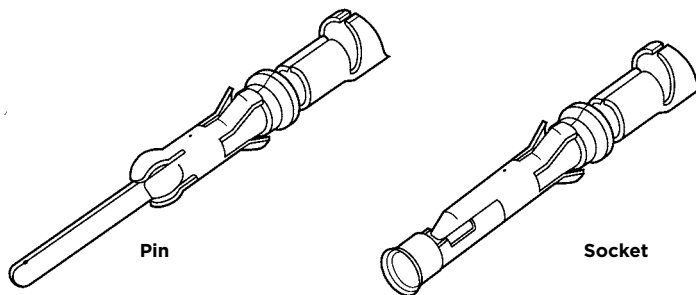

Solder-Type

Solder-Tab

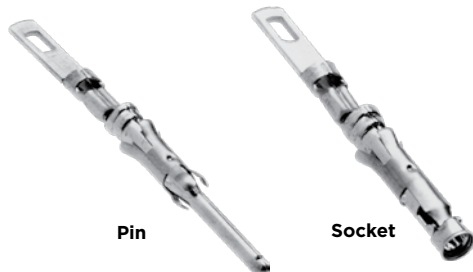
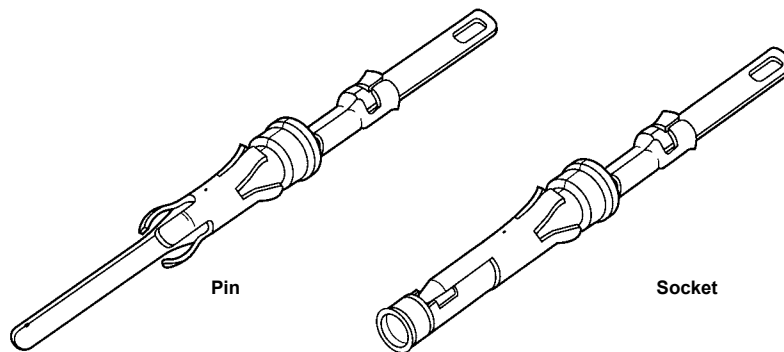

Solder-Tab

Contact Size 16—Pin Diameter .062 [1.57] (Test Current, 13 Ampere)‡

| Wire Size Range | | Contact Finish | Loose Piece Contact No. | |
|-------------------------|-----------------|--------------------------|-------------------------|----------|
| AWG | mm ² | | Pin | Socket |
| 26-20 | 0.12-0.6 | Gold/Nickel ¹ | 66182-1 | 66183-1 |
| 18-16 | 0.8-1.4 | Gold/Nickel ¹ | 66180-1 | 66181-1 |
| Solder Tab ⁴ | | Duplex ² | 202236-7 | 202237-7 |
| | | Bright Tin | 202236-5 | 202237-5 |

¹ .000030 [0.00076] gold in mating area over .000030 [0.00076] min. nickel.

² Duplex plated .000030 [0.00076] gold in mating area over .000030 [0.00076] min. nickel on contact body; bright tin solder tab.

³ Bright tin on entire contact.

⁴ Designed for up to 14 AWG; but, not to exceed current limitation of contact.

Note: These contacts can be used in Multimate contact cavities of all connector housings.

‡ Single contact, free-air test current is not to be construed as contact rating current. Use only for testing.

Refer to contact current carrying capability information on page 8.

Extraction Tool Part No. 305183

Power Contacts

Type I, Crimp, Snap-In



Pin



Socket



Pin



Socket

Power Contacts

Material

Contact Body - Bronze

Retention Spring - Beryllium copper

Finish

Contact Body - .000030 [0.00076] gold over .000050 [0.00127] nickel. Gold thickness controlled on socket O.D.

Retention Spring - Nickel plated

Related Product Data

Application Tooling - Pages 90, 91

Technical Documents

108-10108 Product Specification
114-10037 Application Specification

Size 12—Pin Diameter .094 [2.39] (Test Current, 23 Ampere)†

| Wire Size Range | | Loose Piece Contact No. | | Tooling Part No. | |
|-----------------|--------------------|-------------------------|----------|--------------------------|-----------|
| AWG | [mm ²] | Pin | Socket | Dies for Pneumatic Tool* | Hand Tool |
| 18-16 | 0.8-1.4 | 202421-1 | 202418-1 | 90122 | 90121 |
| 14-12 | 2-3 | 202422-1 | 202417-1 | 90122 | 90121 |

* Use hand actuated Power Unit **Part No. 189721-2** or foot actuated Power Unit **Part No. 189722-2**. Both units require "C" Head Die Set Adapter **Part No. 318161-1** and an Adapter Holder **Part No. 356304-1** (with ratchet) or **Part No. 189928-1** (without ratchet). Request Catalog 124208 for more information on the 626 Pneumatic Tool System.

† Single contact, free-air test current; not to be construed as contact rating current. Use only for testing. Refer to contact current carrying capability information, page 7.

Extraction Tool **Part No. 305183-8** (Instruction Sheet 408-1216)

Power Contacts (Continued)

Type XII, Precision Formed, Crimp, Snap-In

Material

Copper

Finish

- A - Tin
- B - .000030 [0.00076] selective gold over .000030 [0.00076] nickel
- C - .000100 [0.00254] silver plated contacts with lubricant added
- D - RoHS compliant Tin plating

Test Current Rating

Silver or Gold - 35 amperes ‡

Tin or Lead - 15 amperes ‡

‡ Single contact, free-air test current; not to be construed as contact rating current. Use only for testing. Refer to contact current carrying capability information, page 7.

Related Product Data

Application Tooling -
Pages 90, 91

Technical Documents -
Pages 92, 93



Male



Female

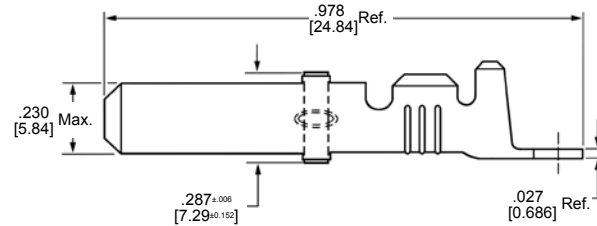
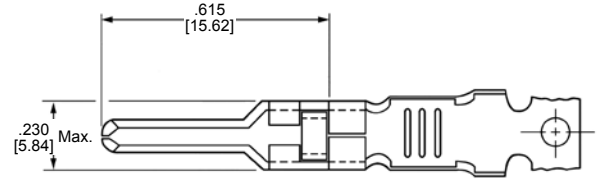

Male

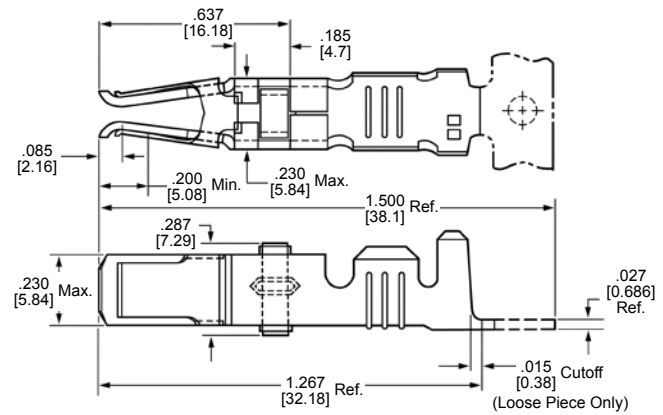

Female



Extraction Tool Part No. 91019-3

| Wire Size Range ¹ | Ins. Dia. Range | Contact Finish | Strip Form Contact Part Nos. | | | | Loose Piece Contact Part Nos. | | Tooling | | |
|------------------------------|----------------------|------------------------|------------------------------|----------------------|-------------------------|-------------------------|-------------------------------|----------------------|---------------------------------|--|---------------------------|
| | | | Standard*** | Standard*** | Heavy Duty Miniature*** | Heavy Duty Miniature*** | Male | Female | Heavy Duty Miniature Applicator | Die Set for Hand Tool 69710-1 or 626 Pneumatic Tool System | |
| AWG | mm ² | | Male | Female | Male | Female | Male | Female | | | |
| 16 and 14-12 | 1.25-1.4 and 2-3 | .135-.160 3.43-4.06 | A | 66255-1 | 66740-7 | 66255-5 | 1-66740-2 | 66261-1 | 66740-8 | 567455-□*** | 90145-23.7 and 90145-14.7 |
| | | | | 66256-1 ² | — | 66256-5 ² | — | 66262-1 ² | — | | |
| | | | B | 66255-2 | 66740-5 | 66255-6 | 1-66740-1 | 66261-2 | 66740-6 | | |
| | | | | 66256-2 ² | — | 66256-4 ² | — | 66262-2 ² | — | | |
| | | | C ⁵ | 66255-7 | 66740-1 | 66255-8 | 66740-9 | 66261-4 | 66740-2 | | |
| | | | | 66256-6 ² | — | 66256-7 ² | — | 66262-4 ² | — | | |
| 16 and 14-12 | | | D | 1-66255-1 | 1-66740-9 | 1-66255-2 | 2-66740-0 | 66261-5 | 2-66740-1 | 567021-□*** | 90140-17 |
| | | | | 66256-8 ² | — | 66256-9 ² | — | 66262-5 ² | — | | |
| | | | A | 66253-1 | 66741-7 | 66253-5 | 1-66741-2 | 66259-1 | 66741-8 | | |
| | | | | 66254-1 ² | — | — | — | 66260-1 ² | — | | |
| | | | B | 66253-2 | 66741-5 | 66253-6 | 1-66741-1 | 66259-2 | 66741-6 | | |
| | | | | 66254-2 ² | — | 66252-5 ² | — | 66260-2 ² | — | | |
| C ⁵ | 66253-4 | 66741-1 | 66253-8 | 66741-9 | 66259-4 | 66741-2 | | | | | |
| | 66254-4 ² | — | — | — | 66260-4 ² | — | | | | | |
| 10 | 5-6 | .190-.220 4.83-5.59 | D | 66253-9 | 1-66741-9 | 1-66253-0 | 2-66741-0 | 66259-5 | 2-66741-1 | | |
| | | | | 66254-6 ² | — | — | — | 66260-5 ² | — | | |

¹Wire strip length—.281 [7.14].

²Ground contact.

³Die insert **Part No. 90145-2** is for crimping 16 AWG [1.25-1.4 mm²] wire.

⁴Die insert **Part No. 90145-1** is for crimping 14-12 AWG [2-3 mm²] wire.

⁵Recommended for high current/vibration applications where fretting corrosion is a problem.

⁷ Die Set requires "C" Head Adapter **Part No. 318161-1**; Adapter Holder **Part No. 356304-1** (with ratchet) or **189928-1** (without); and Power Unit **Part No. 189721-2** (hand actuated) or **189722-2** (foot actuated).

Extraction Tool Part No. 91019-3

***Call the Technical Support Center at 1-800-522-6752 for Automatic Machine Applicator Part Numbers.

Power Contacts (Continued)

Type XII, Crimp, Snap-In

The Multimatte features of the High Current Type XII contact have been designed to fit into the existing AMP Connectors such as CPC (Circular Plastic Connector), CMC (Circular Metal-Shell Connector), G Series, and M Series housings. An initial T-Rise test in free air has shown a **60 amp** capability with a 30° T-Rise with 8 gage wires. The contact may be crimped onto 8 AWG wire with a Daniels Hand Tool M310 or AMP P/N 356114-1 and Positioner TP1068S or AMP P/N 356119-1.

Material

Body - Copper alloy

Louvertac Band - Beryllium copper

Retention Spring - Stainless steel

Finish

Body - Silver

Louvertac Band - Gold

Cable-to-Cable

**Standard
Type XII Socket
(Page 38)**



**Standard
Type XII Pin
(Page 38)**



**High Current
Type XII Socket
Part No. 193990-2**



**High Current
Type XII Pin
Part No. 193991-4**



**Extraction Tool
Part No. 224155-1**

Current-Carrying Capacity. The graph shows current-carrying capacity versus temperature rise for a fully energized 3 position CPC plug P/N 206037-2 and receptacle P/N 206036-2. These initial representative amperage ratings were conducted with 8 AWG wires that were 3 feet long.

- Notes:**
1. High Current contacts with Louvertac bands are **not** intermateable with any other contact.
 2. Additional information on CPC and CMC connectors is available in Tyco Electronics Catalog No. 82021.
 3. Additional information on G Series connectors is available in Tyco Electronics Catalog No. 82046.
 4. Additional information on M Series connectors is available in Tyco Electronics Catalog No. 82003.
 5. Additional information on LGH connectors is available in Tyco Electronics Catalog No. 82024.

Coaxial Contacts

Subminiature, Crimp, Snap-In, Size 16



Pin



Socket



Pin



Socket



Ferrule
Part No. 225088-1—A .120 Dia. [3.05]
225088-3—A .123 Dia. [3.12]



Ferrule
Part No. 1-332056-0



Ferrule
Part No. 1-332057-0

Selection Chart for Coaxial Cable

Material

Outer Shell - Brass per MIL-C-50

Center Conductor - Beryllium copper per QQ-C-533 (Pin); Brass per QQ-B-626 (Socket)

Inner Dielectric - Polypropylene

Retention Spring - Stainless steel per QQ-S-766

Ferrule - Copper per QQ-C-576 or ASTM-B-152 (1-332056-0)

Finish

Outer Shell, Center Conductor—See charts

Ferrule—Tin per MIL-T-10727

| Cable Size (RG/U) | Contact Finish | Loose Piece Contact No. | | Ferrule Part No. | Tooling Part No. | |
|--------------------|--------------------------------------|-------------------------|---------|------------------|--|--------------------|
| | | Pin | Socket | | Die Inserts for Hand Tool 69710-1 or Pneumatic Tool* | Hand Tool |
| 178, 196 | Gold/Nickel Gold/Copper ¹ | 226537-2 | 51565-2 | 1-332057-0 | 69690-2 | 69656-2 |
| | Gold/Nickel Gold/Copper ² | — | 51565-5 | | | |
| 196 (Double Braid) | Gold/Nickel Gold/Copper ¹ | 226537-2 | 51565-2 | 225088-1 | — | 69656-9 |
| | Gold/Nickel Gold/Copper ² | — | 51565-5 | | | |
| 174, 188, 316 | Gold/Nickel Gold/Copper ¹ | 226537-1 | 51565-1 | 1-332056-0 | 69690 | 69656 |
| | Gold/Nickel Gold/Copper ² | 226537-4 | 51565-4 | | | |
| 174 (Double Braid) | Gold/Nickel Gold/Copper ¹ | 226537-1 | 51565-1 | 225088-3 | — | 69656-7 |
| | Gold/Nickel Gold/Copper ² | 226537-4 | 51565-4 | | | |
| 179, 187 | Gold/Nickel Gold/Copper ¹ | 226537-1 | 51565-1 | 1-332056-0 | 69690-1 | 354940-1 & 91911-4 |
| | Gold/Nickel Gold/Copper ² | 226537-4 | 51565-4 | | | |
| 187 (Double Braid) | Gold/Nickel Gold/Copper ¹ | 226537-1 | 51565-1 | 225088-1 | — | 69656-8 |
| | Gold/Nickel Gold/Copper ² | 226537-4 | 51565-4 | | | |
| 161 | Gold/Nickel Gold/Copper ¹ | 226537-1 | 51565-1 | 1-332056-0 | — | — |
| | Gold/Nickel Gold/Copper ² | 226537-4 | 51565-4 | | | |

* Use hand actuated Power Unit **Part No. 189721-2** or foot actuated Power Unit **Part No. 189722-2**. Both units require "C" Head Die Set Adapter **Part No. 318161-1** and an Adapter Holder **Part No. 356304-1** (with ratchet) or **Part No. 189928-1** (without ratchet). Request Catalog 124208 for more information on the 626 Pneumatic Tool System.

Extraction Tool **Part No. 305183**

Coaxial Contacts (Continued)

Subminiature, Crimp, Snap-In, Size 16 (Continued)

Selection Chart for Twisted Pair and Shielded Wire

| Wire Size | | Contact Finish | Loose Piece Contact No. | | Ferrule Part No. | Tooling Part No. | |
|-----------|---|--|-------------------------|---------|------------------|--|-------------------------------------|
| AWG | [mm ²] | | Pin | Socket | | Die Inserts for Hand Tool 69710-1 or Pneumatic Tool* | Hand Tool |
| 30 | 0.05 | Gold/Nickel Gold/Copper ¹ | 226537-3 | 51565-3 | 1-332057-0 | 69690-2 | 69656-2 |
| 28 | 0.08-0.09 | Gold/Nickel Gold/Copper ¹ | 226537-3 | 51565-3 | 1-332057-0 | 69690 | 69656 |
| 28 | 0.08-0.09 (Twisted Pair, Stranded 7 Str., .0050 [0.13] Dia.) | Gold/Nickel ¹ Gold/Copper | 226537-3 | 51565-3 | 1-332057-0 | 69690-1 or 69690-2 | 354940-1 & 91911-4 or 69656-2 |
| 26 | 0.12-0.15 (Twisted Pair, Solid or Stranded 7 Str. .0063 [0.16] Dia.) | Gold/Nickel ¹ Gold/Copper | 226537-3 | 51565-3 | 1-332057-0 | 69690 | 69656 |
| 26 | 0.12-0.15 (Shielded, .075 [1.91] Max. O.D.) | Gold/Nickel Gold/Copper ¹ Gold/Nickel Gold/Copper ² | 226537-1 | 51565-1 | 1-332057-0 | 69690-3 | 69656-3 |

¹ 000030 [0.00076] gold over .000050 [0.00127] nickel—outer shell and socket center conductor; .000030 [0.00076] gold over .000100 [0.00254] copper—pin center conductor.

² 000050 [0.00127] gold over .000050 [0.00127] nickel—outer shell and socket center conductor; .000050 [0.00127] gold over .000100 [0.00254] copper—pin center conductor.

* Use hand actuated Power Unit **Part No. 189721-2** or foot actuated Power Unit **Part No. 189722-2**. Both units require "C" Head Die Set Adapter **Part No. 318161-1** and an Adapter Holder **Part No. 356304-1** (with ratchet) or **Part No. 189928-1** (without ratchet). Request Catalog 124208 for more information on the 626 Pneumatic Tool System.

Note: A ferrule is required for each pin and socket.
Extraction Tool Part No. 305183

Coaxial Contacts (Continued)

Miniature, Crimp, Snap-In, Size 12



Pin



Socket



Ferrule

Retention Spring
Part No. 201142-1

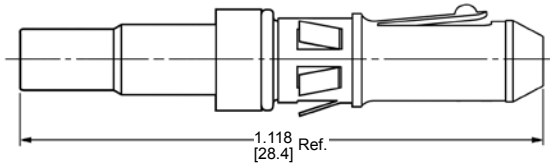

Pin



Socket

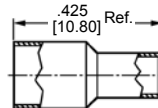

Ferrule

Material

Outer Shell - Brass per MIL-C-50

Center Conductor - Brass per QQ-B-626

Inner Dielectric - Polymethylpentene

Retention Spring - Beryllium copper per QQ-C-533

Ferrule - Copper per QQ-C-576

Finish

Outer Shell, Center Conductor - See charts on next page

Retention Spring - Nickel per QQ-N-290

Ferrule - Tin per MIL-T-10727

Extraction Tool **Part No. 305183-8**

Coaxial Contacts (Continued)

Miniature, Crimp, Snap-In, Size 12 (Continued)

Selection Chart for Coaxial Cable

| Cable Size (RG/U) | Contact Finish | Loose Piece Contact No. | | Ferrule Part No. | Tooling Part No. | |
|--------------------------------------|--|-------------------------|----------|------------------|--|-----------------------|
| | | Pin | Socket | | Die Inserts for Hand Tool 69710-1 or Pneumatic Tool* | Hand Tool |
| | | | | | | |
| 55, 55A, 55B 141, 142, 223 | Gold/Nickel ¹ Gold/Copper ² | 201145-4 | 201146-4 | 330478 | 69315-4 | 69248-4 |
| 58, 58A, 58B, 58C | Gold/Nickel ¹ Gold/Copper ² | 201145-4 | 201146-4 | 328663 | 69220-2 | 45740-2 |
| 174, 179A, 187, 21-598 | Gold/Nickel ¹ Gold/Copper ² | 201143-1 | 201144-1 | 328666 | 69227-2 | 354940-1 & 91912-3 |
| 180, 180A, 195, 21-597 | Gold/Nickel ¹ Gold/Copper ² | 201145-2 | 201146-2 | 328664 | 69222-2 | 45639-2 |
| 178, 178A, 196 | Gold/Nickel ¹ | 201511-1 | 201512-1 | 328667 | 69373 | 69186-2 |
| 188 | Gold/Nickel ¹ Gold/Copper ² | 201143-5 | 201144-5 | 328666 | 69227-2 | 354940-1 & 91912-4 |
| 122 | Gold/Nickel ¹ | 201145-1 | — | 328664 | 69222-2 | 45639-2 |
| 188 Double Braid 316 Double Braid | Gold/Nickel ¹ Gold/Copper ² | 201143-5 | 201144-5 | 221848-3 | — | 58290-1 |
| Special .125, .100, .066, .012DB | Gold/Nickel ¹ | 201143-1 | 201144-1 | 221848-3 | — | 58290-1 |

Selection Chart for Twisted Pair

| Wire Size AWG [mm ²] | Max. Ins. Dia. (Two Wires Combined) | Contact Finish | Loose Piece Contact No. | | Ferrule Part No. | Tooling Part No. | |
|-----------------------------------|-------------------------------------|--|-------------------------|----------|------------------|--|-----------------------|
| | | | Pin | Socket | | Die Inserts for Hand Tool 69710-1 or Pneumatic Tool* | Hand Tool |
| | | | | | | | |
| 28-26 0.08-0.15 (Solid) | .080 2.03 | Gold/Nickel ¹ | 201511-1 | 201512-1 | 328667 | 69373 | 345940-1 & 91912-3 |
| 24-22 0.2-0.4 (Stranded) | .115 2.92 | Gold/Nickel ¹ Gold/Copper ² | 201143-5 | 201144-5 | 328666 | 69672 | 45638-3 |
| 24-22 0.2-0.4 (Solid or Stranded) | .160 4.06 | Gold/Nickel ¹ | 50079-1 | 50080-1 | 329029 | 69222-2 | 45639-2 |

Selection Chart for Shielded Wire

| Shielded Wire | | Contact Finish | Loose Piece Contact No. | | Ferrule Part No. | Tooling Part No. | |
|---------------|----------------------|--|-------------------------|----------|------------------|--|-----------------------|
| AWG | No. | | Pin | Socket | | Die Inserts for Hand Tool 69710-1 or Pneumatic Tool* | Hand Tool |
| | | | | | | | |
| 22 | NAS-702, Class A | Gold/Nickel ¹ | — | 201144-3 | 328666 | 69227-2 | 354940-1 & 91912-3 |
| 22 | MIL-C-7078A, Type II | Gold/Nickel ¹ Gold/Copper ² | 201145-4 | 201146-4 | 328663 | 69220-2 | 45740-2 |

Selection Chart for Various Manufacturers' Cables

| Cable Size Type/AWG | Dielectric O.D. (Max.) [mm ²] | Cable O.D. Range | Braid | Contact Finish | Loose Piece Contact No. | | Ferrule Part No. | Tooling Part No. | | |
|--|---|------------------|------------------------|----------------|--|----------|------------------|--|-----------|---------|
| | | | | | Pin | Socket | | Die Inserts for Hand Tool 69710-1 or Pneumatic Tool* | Hand Tool | |
| | | | | | | | | | | |
| Brand-Rex T209A 29 AWG | 0.08 | .076 1.93 | .112-.122 2.84-3.10 | Single | Gold/Nickel ¹ | — | 201146-6 | 330587 | — | — |
| Brand-Rex T5788A 26 AWG | 0.12-0.15 | .106 2.69 | .160 4.06 | Single | Gold/Nickel ¹ Gold/Copper ² | 201145-2 | 201146-2 | 328664 | 69222-2 | 45639-2 |
| RAYCHEM 0030D1314 Army Ord. 11207177 32-26 AWG | 0.03-0.15 | .129 3.28 | .122-.137 3.10-3.48 | Single | Gold/Nickel ¹ | — | 201146-6 | 330587 | — | — |

¹ .000030 [0.00076] gold over .000030 [0.00076] nickel.

² .000100 [0.00254] gold over .000100 [0.00254] copper.

* Use hand actuated Power Unit **Part No. 189721-2** or foot actuated Power Unit **Part No. 189722-2**. Both units require "C" Head Die Set Adapter **Part No. 318161-1** and an Adapter Holder **Part No. 356304-1** (with ratchet) or **Part No. 189928-1** (without ratchet). Request Catalog 124208 for more information on the 626 Pneumatic Tool System.

Note: A ferrule and retention spring (**201142-2**) are required for each pin and socket.

Engineering Notes



Standard Housings



Standard connectors are furnished as unloaded housings that have Multimate contact cavities for accepting Type II, Type III+, and subminiature COAXICON crimp-type contacts, as well as Type III+ solder-type and posted contacts. All Multimate contacts are interchangeable in the same housing cavity.

Standard connector housings are available in sizes ranging from 6 thru 160 positions. They mate with each other, as well as posted connectors of a corresponding size for hand tool and semiautomatic machine wiring. See Posted Connector section.

Standard Housings (Continued)

6 Position

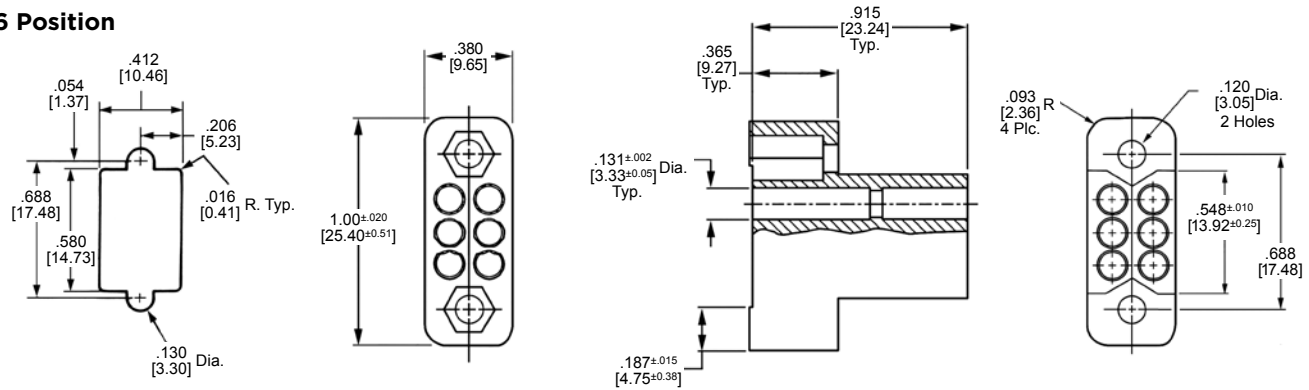

Recommended Panel Cutout

Plug Housing
Phenolic Part No. 202758-1
Diallyl Phthalate Part No. 202758-3

Receptacle Housing
Phenolic Part No. 202757-1
Diallyl Phthalate Part No. 202757-3

14 Position

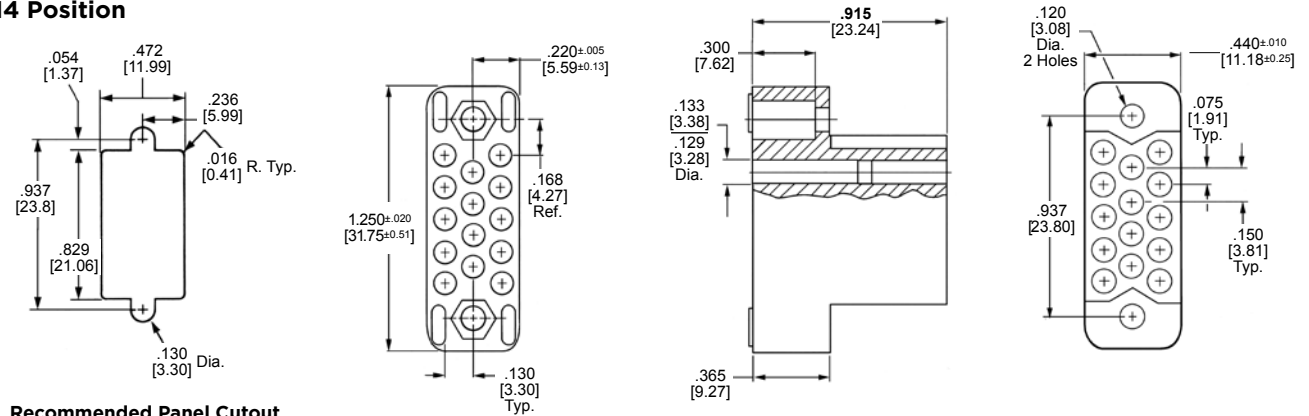

Recommended Panel Cutout

Plug Housing
Phenolic Part No. 201355-1

Receptacle Housing
Phenolic Part No. 201298-1
Diallyl Phthalate Part No. 201298-3

20 Position

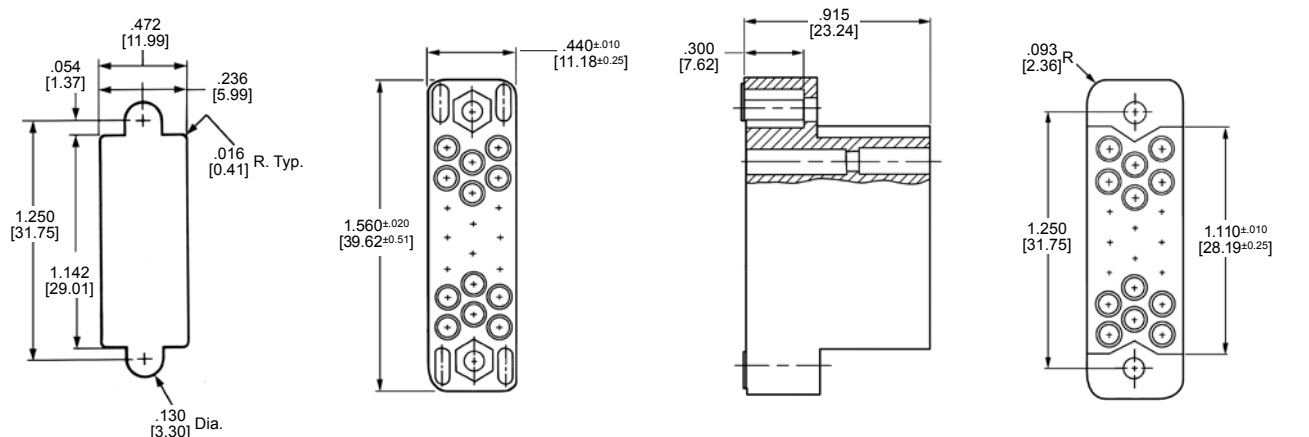

Recommended Panel Cutout

Plug Housing
Phenolic Part No. 201356-1
Diallyl Phthalate Part No. 201356-3

Receptacle Housing
Phenolic Part No. 200346-2
Diallyl Phthalate Part No. 200346-4

- Notes:**
1. All housings accept Type II, Type III+, and Subminiature COAXICON contacts.
 2. Pins and/or sockets may be used in any housing.
 3. Dimensions are 3.005 [0.127], unless otherwise noted.
 4. Housing cavity identification are mirror image.

NOTE: All part numbers
are RoHS Compliant

Standard Housings (Continued)

26 Position



Recommended Panel Cutout



Plug Housing (Shown)



34 Position



Recommended Panel Cutout



Plug Housing (Shown)

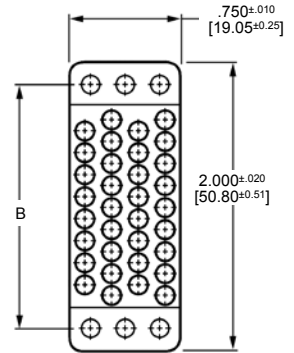

36 Position



Recommended Panel Cutout



Plug Housing (Shown)

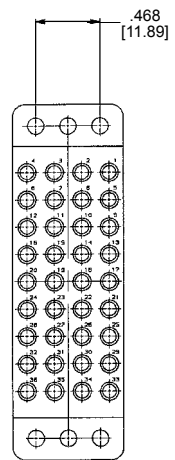

Standard Housings

Standard Housings (Continued)

26, 34 and 36 Positions (Continued)

| No. of Pos. | Housing Material | Plug Part Number | Dimension A | Receptacle Part Number | Dimension B |
|-------------|-------------------|----------------------------------|-----------------------|------------------------|-----------------------|
| 26 | Phenolic | 201359-1 | 1.312 33.32 | 200512-2 | 1.312 33.32 |
| | Diallyl Phthalate | 201359-3 | 1.322 33.58 | 200512-3 | 1.322 33.58 |
| 34 | Phenolic | 1-201357-1 | 1.686 42.82 | 200838-2 | 1.686 42.82 |
| | | 213799-1 (Modified) | | 213801-1 (Modified) | |
| | Polyester | 213800-1 213800-2 (Pins only) | 213802-1 | — | |
| | Diallyl Phthalate | 201357-3 | 1.696 43.08 | 200838-3 | 1.696 43.08 |
| 36 | Phenolic | 203956-2 | 2.281 57.94 | — | — |

Related Product Data

Dimensions—Page 46

- Notes:**
- All housings accept Type II, Type III+, and Subminiature COAXICON contacts.
 - Pins and/or sockets may be used in any housing, except for 213800-2, which accepts only pin contacts.
 - Dimensions are 3.005 [0.127], unless otherwise noted.
 - Housing cavity identification are mirror image.

41 Position

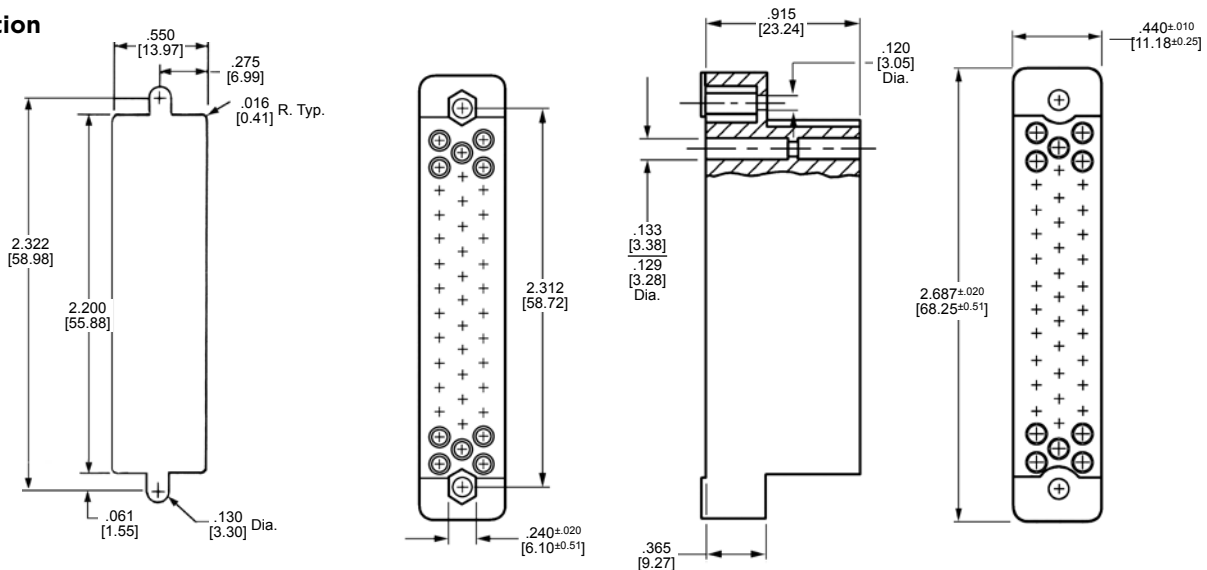

Recommended Panel Cutout

Plug Housing
Phenolic Part No. 202135-2
Diallyl Phthalate Part No. 202135-4

Receptacle Housing
Phenolic Part No. 201302-1
Diallyl Phthalate Part No. 201302-3

50 Position

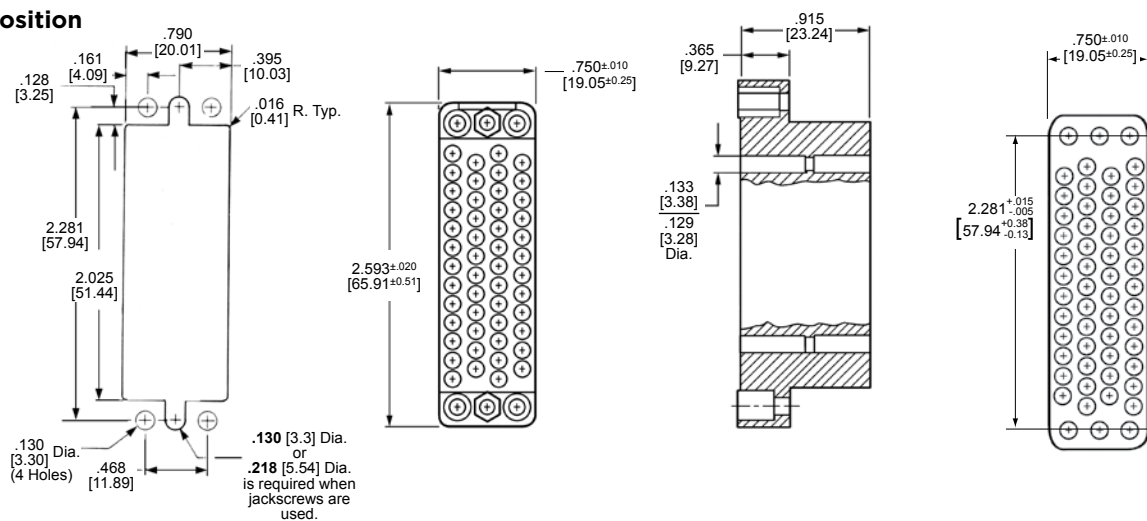

Recommended Panel Cutout

Plug Housing
Phenolic Part No. 201358-1
Diallyl Phthalate Part No. 201358-3

Receptacle Housing
Phenolic Part No. 200277-2
Diallyl Phthalate Part No. 200277-4

Standard Housings (Continued)

50 Position



Recommended Panel Cutout

Plug Housing
Phenolic Part No. 203622-2

(Mating face contact cavities numbered left to right.)

50 Position

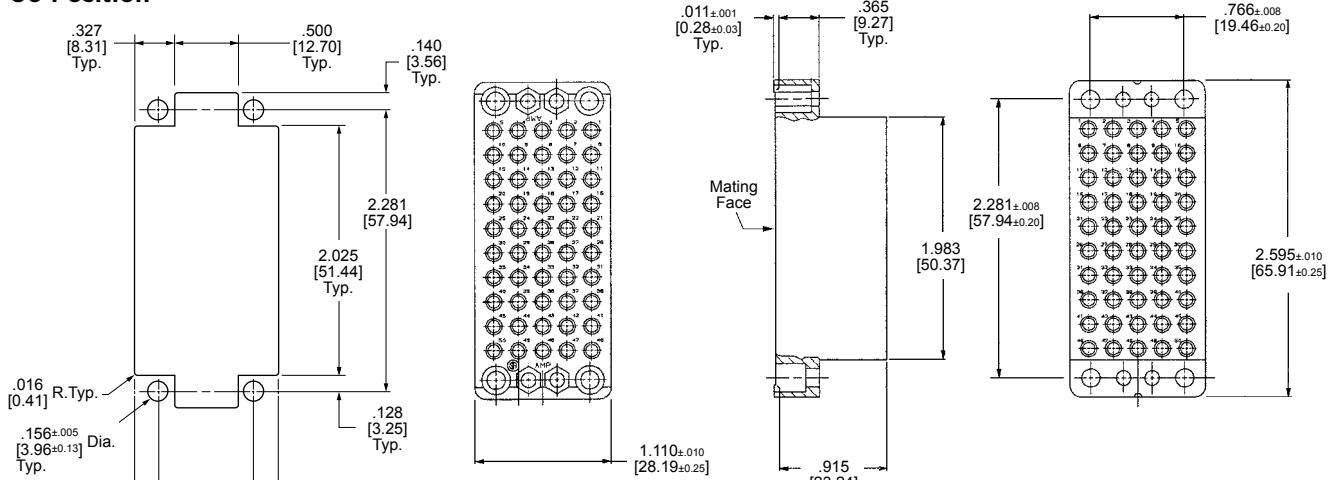

Recommended Panel Cutout

Plug Housing
Phenolic Part No. 205058-2

(Mating face contact cavities numbered right to left.)

Standard Housings (Continued)

75 Position



Recommended Panel Cutout

Plug Housing
Phenolic Part No. 201310-1
Diallyl Phthalate Part No. 201310-3

Receptacle Housing
Phenolic Part No. 201311-1
Diallyl Phthalate Part No. 201311-3

104 Position



†.218 [5.54] diameter is required when jackscrews are used.

Recommended Panel Cutout

Plug Housing
Phenolic Part No. 201345-1

Receptacle Housing
Phenolic Part No. 201037-1

- Notes:**
1. All housings accept Type II, Type III+, and Subminiature COAXICON contacts.
 2. Pins and/or sockets may be used in any housing.
 3. Dimensions are 3.005 [0.127], unless otherwise noted.
 4. Housing cavity identification are mirror image.

Standard Housings (Continued)

104 CF Position
(with Center Fastener)



Recommended Panel Cutout



Plug Housing



Receptacle Housing



Standard Housings

| Center Fastener Description | Center Fastener Length | Plug Housing Part No. | | | Receptacle Housing Part No. | | |
|--------------------------------|---------------------------|-----------------------|----------------------|------------|-----------------------------|----------------------|-----------|
| | | Phenolic | Diallyl Phthalate | Polyester | Phenolic | Diallyl Phthalate | Polyester |
| "T" Handle | 2.500 63.50 | 201692-4 | 201692-3 | 1-201692-6 | | | |
| Slotted Hex | 2.500 63.50 | 201692-6 | — | — | 201532-4 | 201532-2 | — |
| Slotted Hex | .531 13.49 | 201692-2 | — | — | | | |

- Notes:**
1. All housings accept Type II, Type III+, and Subminiature COAXICON contacts.
 2. Pins and/or sockets may be used in any housing.
 3. Dimensions are 3.005 [0.127], unless otherwise noted.
 4. Housing cavity identification are mirror image.

Standard Housings (Continued)

160 CF Position
(with Center Fastener)



Recommended Panel Cutout



Plug Housing
Phenolic Part No. 202799-2
Diallyl Phthalate Part No. 202799-1



Receptacle Housing
Phenolic Part No. 202800-2
Diallyl Phthalate Part No. 202800-1

- Notes:**
1. All housings accept Type II, Type III+, and Subminiature COAXICON contacts.
 2. Pins and/or sockets may be used in any housing.
 3. Dimensions are 3.005 [0.127].
 4. Housing cavity identification are mirror image.

Posted Connectors



Posted connectors are furnished preloaded with Size 16, posted contacts (as shown on page 32) and are specifically designed to be wired with hand tools and semiautomatic machines. The cavity centerline spacing is too close to accommodate the heads and mandrels of fully automatic machines. Post configurations of the preloaded contacts are available for accepting TERMI-POINT Clip and wrap-type terminations.

Posted connector housings are made of black phenolic or diallyl phthalate and are available in sizes ranging from 6 thru 104 positions. They will mate with correspondingly sized standard connector (except .200 [5.08] grid) housings loaded with Size 16 crimp-type contacts. It is not recommended to mate two posted connectors. Since the preloaded posted contacts are rigid in the housing, mating two posted connectors, particularly of the larger sizes, would be difficult.

Posted connectors can be substituted for standard connectors in the Connector/ Hardware Selection Charts, pages 10 to 25.

Tyco Electronics does not recommend the use of shields or strain relief clamps with posted connectors because of the potential of shorting.

Posted Connectors (Continued)

6 Position

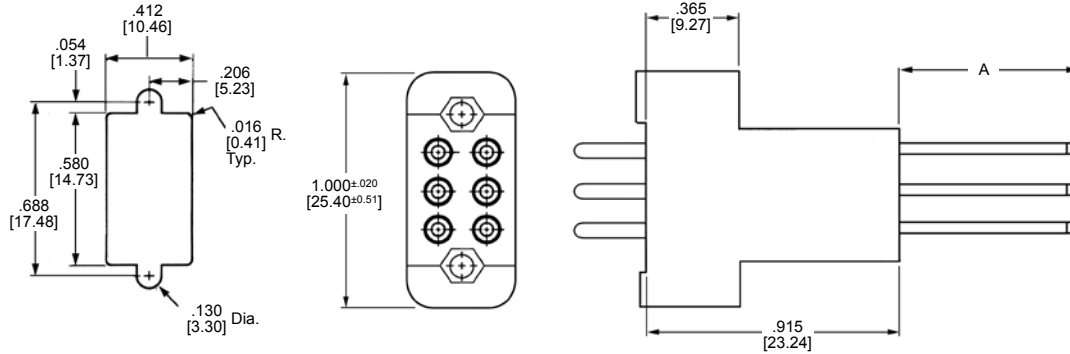

Recommended Panel Cutout

Plug Assembly

14 Position



Recommended Panel Cutout

Plug Assembly

Receptacle Assembly

20 Position



Recommended Panel Cutout

Plug Assembly

Posted Connectors (Continued)

26 Position



Recommended Panel Cutout

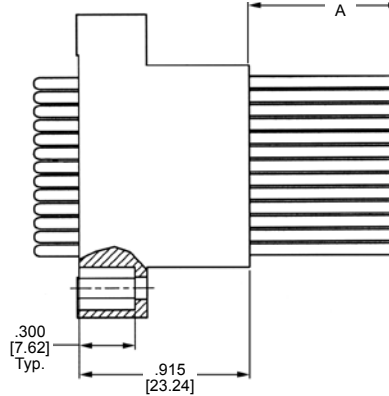

Plug Assembly

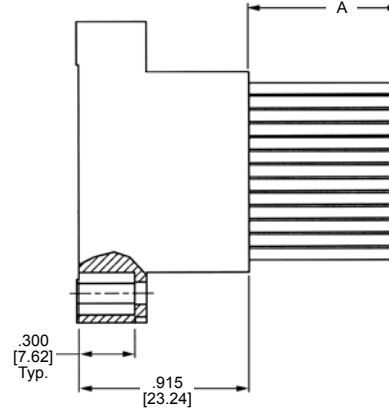
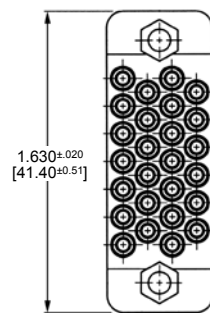
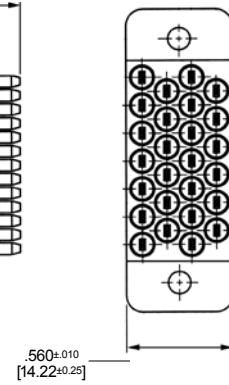

Receptacle Assembly

Plug and Receptacle Assemblies

| No. of Pos. | Termination Method | Post Configuration | A Dimension | Contact Finish | Plug Assembly Part No. | Receptacle Assembly Part No. |
|-------------|--------------------|----------------------------|---------------|----------------------------------|------------------------|------------------------------|
| 6 | Wrap Type | .025 x .025 0.64 x 0.64 | .659 16.74 | Sel. Gold/Nickel ¹ | 205507-1 | — |
| 14 | Wrap Type | .025 x .025 0.64 x 0.64 | .659 16.74 | Sel. Gold/Nickel ¹ | 205317-1 | — |
| | | | .261 6.63 | | — | 3-205508-1 |
| 20 | Wrap Type | .025 x .025 0.64 x 0.64 | .659 16.74 | Sel. Gold/Nickel ¹ | 205509-1 | — |
| 26 | TERMI-POINT Clip | .031 x .062 0.79 x 1.57 | .810 20.57 | Sel. Gold/Nickel ¹ | 1-205512-3 | 1-205511-3 |

¹ Gold flash over .000050 [0.00127] nickel on entire contact, with .000030 [0.00076] gold to a distance of .200 [5.08] from mating end. Posts are plated tin-lead over copper.

Notes: 1. Posted connectors listed above have black phenolic housings.

2. Replacement contacts are shown on page 32.

3. These posted connectors mate with standard connector housings shown on pages 45-47.

Posted Connectors (Continued)

34 Position



Plug Assembly



Receptacle Assembly

†.218 [5.54] diameter is required when jackscrews are used.

Recommended Panel Cutout

Posted Connectors

Posted Connectors (Continued)

50 Position



Recommended Panel Cutout

†.218 [5.54] diameter is required when jackscrews are used.

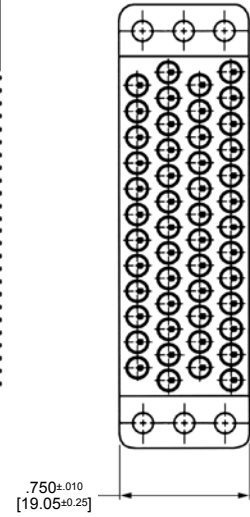
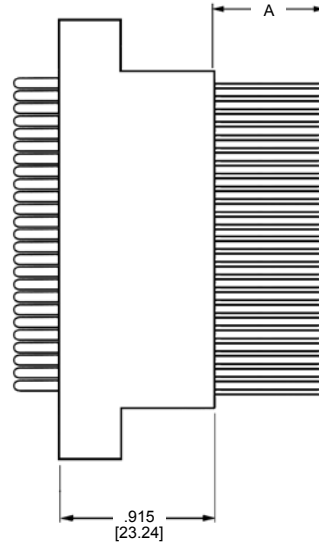
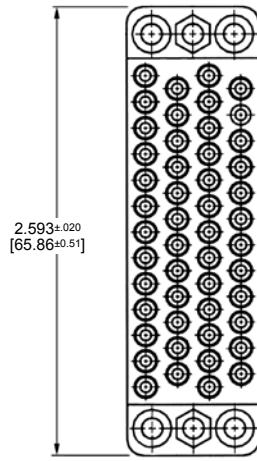

Plug Assembly

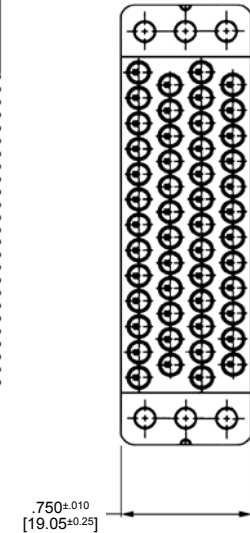
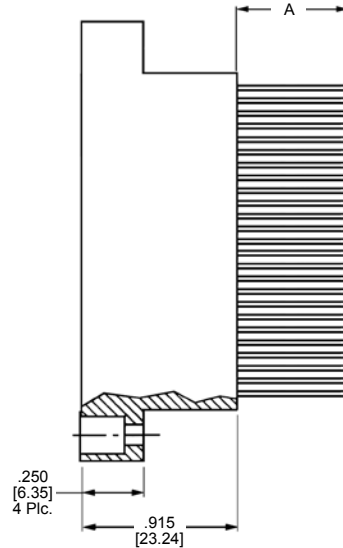
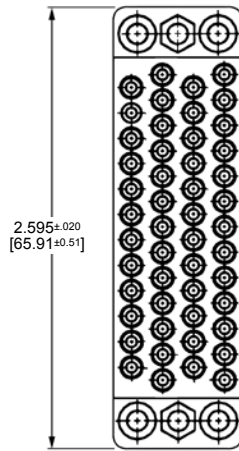

Receptacle Assembly

Plug and Receptacle Assemblies

| No. of Pos. | Termination Method | Post Configuration | A Dimension | Contact Finish | Plug Assembly Part No. | Receptacle Assembly Part No. |
|-------------|--------------------|----------------------------|---------------|-------------------------------|------------------------|------------------------------|
| 34 | Wrap Type | .025 x .025 0.64 x 0.64 | .659 16.74 | Sel. Gold/Nickel ¹ | 205361-1 | 205505-1 |
| | | | .261 6.63 | Sel. Gold/Nickel ¹ | — | 3-205505-1 |
| 50 | Wrap Type | .025 x .025 0.64 x 0.64 | .659 16.74 | Sel. Gold/Nickel ¹ | 205156-1 | 205514-1 |
| | | | .261 6.63 | Sel. Gold/Nickel ¹ | — | 3-205514-1 |

¹ Gold flash over .000050 [0.00127] nickel on entire contact, with .000030 [0.00076] gold to a distance of .200 [5.08] from mating end. Posts are plated tin-lead over copper.

Notes: 1. Posted connectors listed above have black phenolic housings.

2. Replacement contacts are shown on page 32.

3. These posted connectors mate with standard connector housings shown on pages 46-47.

Posted Connectors (Continued)

75 Position

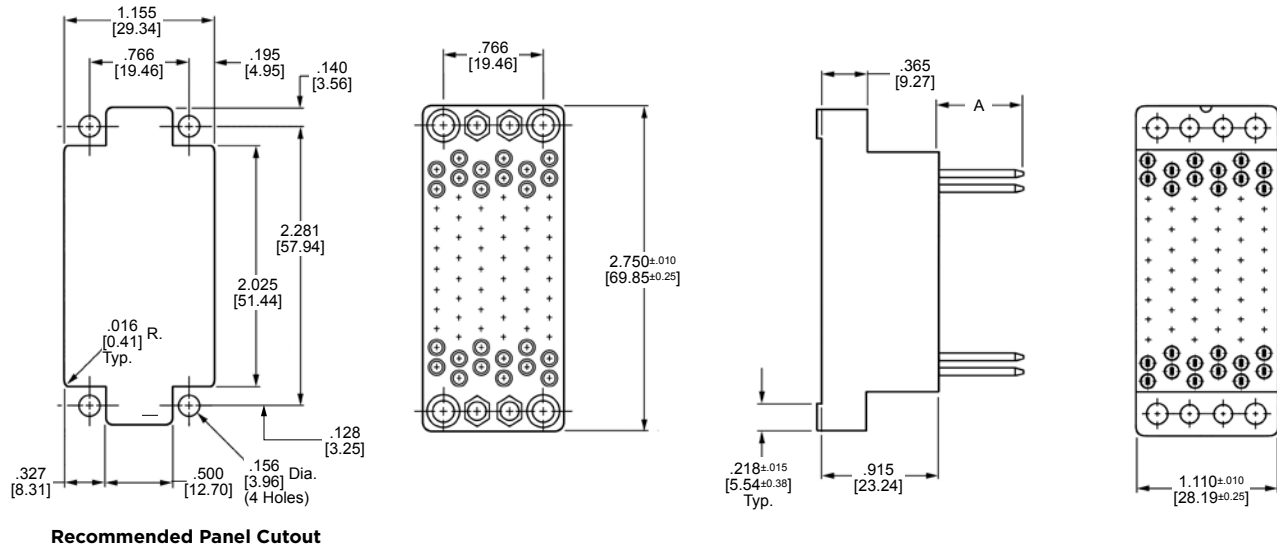

104 Position

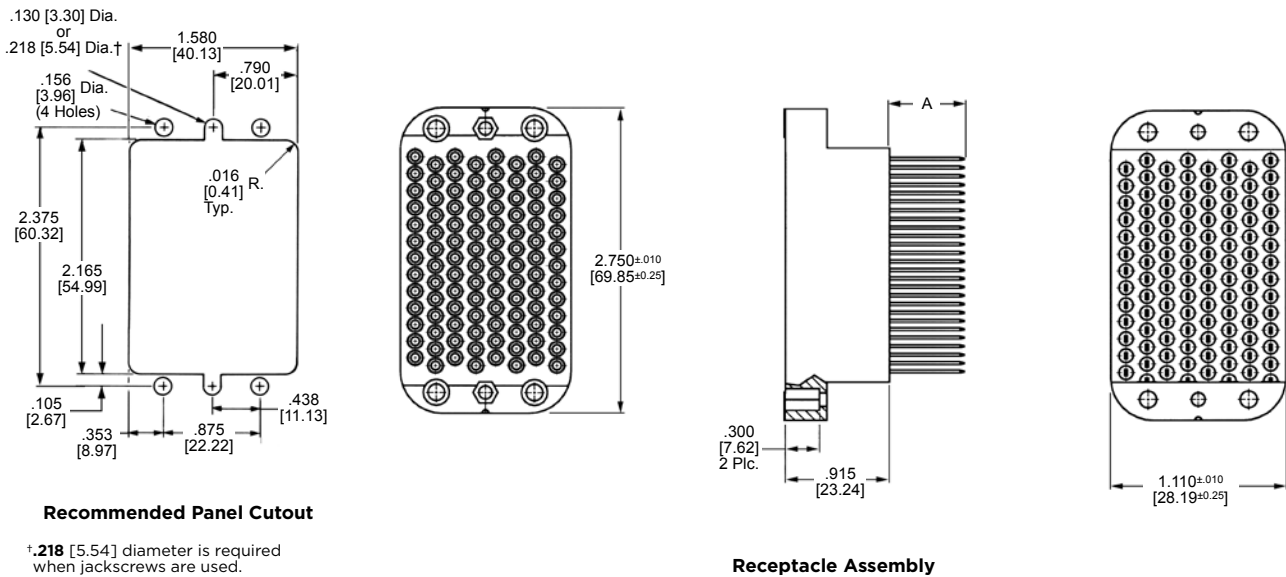

Receptacle Assemblies

| No. of Pos. | Termination Method | Post Configuration | A Dimension | Contact Finish | Receptacle Assembly Part No. |
|-------------|--------------------|----------------------------|---------------|-------------------------------|------------------------------|
| 75 | Wrap-Type | .025 x .025 0.64 x 0.64 | .659 16.74 | Sel. Gold/Nickel ¹ | 205515-1 |
| 104 | Wrap-Type | .025 x .025 0.64 x 0.64 | .659 16.74 | Sel. Gold/Nickel ¹ | 205359-1 |

¹ Gold flash over .000050 [0.00127] nickel on entire contact, with .000030 [0.00076] gold to a distance of .200 [5.08] from mating end. Posts are plated tin-lead over copper.

- Notes:**
1. Posted connectors listed above have black phenolic housings.
 2. Replacement contacts are shown on page 32.
 3. These posted connectors mate with standard connector housings shown on page 49.

NOTE: All part numbers are RoHS Compliant

Posted Connectors with Center Fastener

**104 CF Position
(with Center Fastener)**



Recommended Panel Cutout

Receptacle Assembly (With Posted Socket Contacts)

**104 CF Position
(with Center Insert)**



**160 CF Position
(with Jackscrew Socket)**



Receptacle Assembly (With Posted Pin Contacts)

Posted Connectors

Posted Connectors with Center Fastener (Continued)

Receptacle Assembly

| No. of Pos. | Termination Method | Post Configuration | Housing Material (Color) | A Dimension | Contact Finish | Receptacle Assembly Part No. | Mating Plug Assembly Part No. |
|-------------|--------------------|-----------------------------------|--------------------------|----------------------|-------------------------------|-------------------------------|-------------------------------|
| 104 CF | Wrap-Type | .025 x .025 0.64 x 0.64 | Phenolic (Black) | .659 16.74 | Sel. Gold/Nickel ¹ | 205720-2 | Page 50 |
| | | | Diallyl Phthalate (Blue) | .261 6.63 | Sel. Gold/Nickel ¹ | 205720-1 | |
| | | | | | .261 6.63 | Sel. Gold/Nickel ² | — |
| 160 CF | Wrap-Type | .025 x .025 0.64 x 0.64 | Diallyl Phthalate (Blue) | .261 6.63 | Sel. Gold/Nickel ² | 213521-1 | 202799 (Page 51) |

¹ Gold flash over .000050 [0.00127] nickel on entire contact, with .000030 [0.00076] gold to a distance of .200 [5.08] from mating end. Posts are plated tin-lead over copper.

² Gold flash over .000050 [0.00127] nickel on entire contact, with .000030 [0.00076] gold to a distance of .250 [6.53] from mating end. Posts are plated tin-lead over copper.

Extraction Tool Part No. 305183.

Note: Replacement contacts (Type III+ posted) are shown on page 32.

Posted Connectors, .200 [5.08] Grid

36 Position



Recommended Panel Cutout



Plug Assembly (With Posted Pin Contacts)



50 Position



Recommended Panel Cutout



Plug Assembly (With Posted Pin Contacts)



Posted Connectors

Material and Finish

Housing - Phenolic per MIL-M-14, Type CFG; color, black

Contacts - Brass per MIL-C-50; selective .000030 [0.00076] gold over .000050 [0.00127] nickel plated (gold plating per MIL-G-45204, nickel plating per QQ-N-290)

Plug Assemblies

| No. of Pos. | Termination Method | Post Configuration | Post Length [†] | Contact Finish | Plug Assembly Part Number | Mates with Receptacle Assembly Part Number |
|-------------|--------------------|--------------------|--------------------------|-------------------------------|---------------------------|--|
| 36 | TERMI-POINT | .031 x .062 | .810 | Sel. Gold/Nickel [‡] | 205629-1▲ | ▲ |
| 50 | Clip | 0.79 x 1.57 | 20.57 | | 205630-1△△ | △△ |

[‡]Gold flash over .000050 [0.00127] nickel on entire contact with .000030 [0.00076] gold to a distance of .200 [5.08] from mating end. Posts are plated tin-lead over copper.

[†]Post length will accommodate up to 3 terminations.

Extraction Tool-Part No. 305183.

Refer to page 32 for contact specifications (Type III+, Size 16).

▲ Mating receptacle block using crimp, snap-in contacts for 36-Position Plug Assembly, order **Part No. 203956-2.**

△△ Mating receptacle block using crimp, snap-in contacts for 50-Position Plug Assembly, order **Part No. 203622-2.**

Refer to the appropriate column of Application Chart for Hardware Selection Page 10 through Page 25.

Note: 36 position connector uses standard 50 position hardware. 50 position connector uses standard 75 position hardware.

Special Application Connectors



Special Application Connectors are available in the following configurations:

- V.35
- Shallow Block
- High Current
- Mixed
- High Voltage
- RFI/EMI Shielded
- Grounding Blocks

V.35 Connector

The 34 position V.35 Connector is fully assembled and ready for placement on a printed circuit board. They are also available in kit form for cable assembly. These AMP V.35 connectors meet the requirements of 408-2593 for CCITT V.35 interfacing.

High current connectors are designed for applications requiring up to 25 amperes of current. They are available in 12-position male and female housings which have rectangular contact cavities for accepting Type XII contacts.

Mixed connectors are designed for applications that require intermixing signal, power and/or coaxial circuits in the same connector

housing. Housings are available in 15-, 16-, 29 CF (center fastener) and 42-position sizes and, depending upon the specific configuration, will accept Multimate contacts, Type I and Miniature, Standard and Twin Standard COAXICON contacts. The rectangular contact cavities accept Type XII contacts.

High voltage connectors are designed for high voltage applications using Multimate contacts. The cavity centerline spacings and the silo construction of the contact cavities increase the current creepage path for higher voltage ratings. Housing sizes include 20 and 28 positions.

RFI/EMI shielding kits provide shielding capabilities against radio frequency and electromagnetic interferences. Special 104-position housings accept Multimate contacts and are especially designed for use with shielding hardware. These shielding kits cannot be used with the standard 104-position connector housings.

Grounding blocks are ideally suited for aircraft applications, where shielded cable is to be grounded to an airframe. The ground wires of shielded cables are pigtailed off with ferrules and are crimped to Size 16 socket contacts. The contacts are loaded into a standard 14- or 34-position connector housing. This connector then can be mated to the grounding block which is fastened to the aircraft frame. Grounding blocks have Size 16 screw-machined pin contacts which are staked, riveted and soldered into the L-shaped metal bracket. The bracket has fixed jackscrew receptacles that will accept the special turnable jackscrews fastened to the mating socket connector half.

M Series V.35 Special Application Connectors

Product Facts

- Meets requirements of 408-2593 for CCITT V.35 interface
- Pcb connectors fully assembled, right-angle and vertical mount
- Mounting bracket secures pcb connector to board
- Pcb connectors pre-loaded with Size 16 contacts
- Right-angle connector features true position location wafer
- Intermateable with comparable M Series connectors
- Cable connector kits available with 1-piece stamped and formed shield or new, more durable die cast 2-piece shield
- Cable connectors accept Size 16, Type III+ strip form or loose piece contacts
- Housings made of UL 94V-0 rated flame retardant material
- Recognized under the Component Program of the Underwriters Laboratories Inc. for 250 volts, File No. E28476 
- Certified by Canadian Standards Association, File No. LR7189 



The 34-position V.35 includes both printed circuit board mount and cable mount configurations.

The pcb connectors are fully assembled and ready for placement on printed circuit boards. Available in vertical or right-angle mount versions, they offer dependable, convenient assembly in high-speed data transmission applications. Connectors are preloaded with economical, dependable Size 16 precision stamped and formed contacts. Contact posts feature a chamfered lead-in that eases assembly to the pc boards. A mounting bracket for securing the connector to the pc board is standard equipment. Right-angle pcb connectors feature true position, location wafers that provide for the exact location of each post. Both the right-angle and vertical mount pcb connectors are fully mateable with comparable M

Series connectors.

Cable connector assemblies are offered in kit form. Each kit contains: a 34-position housing; one-piece or two-piece shield; two, one-piece turnable jackscrews; strain relief clamp; and necessary mounting screws. Shields are offered in an economical one-piece stamped and formed version or a more durable two-piece die cast version. A choice of die cast zinc, nickel plated or stainless steel turnable jackscrews are available. Cable connectors accept Size 16, Type III+ pin and socket contacts. (Contacts sold separately, see page 31.)

AMP M Series V.35 Special Application Connectors meet the requirements of ISO 2593 for CCITT V.35 interface.

Technical Documents

Product Specifications—
108-10001 M Series 042 Type

M Series V.35 Special Application Connectors (Continued)

Material Specifications Contacts

The material composition and construction of AMP Type III+ contacts encompasses varying price ranges and performance characteristics. Specific materials and available plating thicknesses of each contact are provided.

Housings

M Series V.35 connector housings are made of general purpose phenolic (black) or polyester (black). Phenolic housings are molded of material per MIL-M-14, Type CFG. The performance characteristics of this material makes the connector an excellent choice in applications where exceptional resistance to acids, alkalis, or solvents is not a prime factor.

Hardware

A variety of materials such as plated steel, stainless steel, zinc (nickel plated) and aluminum are used in the manufacture of M Series V.35 connector hardware. This provides for the proper operation and durability of each hardware component, while offering a choice of economies to satisfy particular application requirements.

Current Carrying Capabilities

The total current capacity of each contact in any given M Series connector is dependent upon the heat rise resulting from the combination of electrical loads of all contacts in the connector arrangement and the maximum ambient temperature in which the connector will be operating. Caution must be taken to insure that this combination of conditions does not cause the internal temperature of the connector to exceed the maximum operating temperature of the housing material. Several variables which must be considered when determining this maximum current capability for your application are:

- a) Wire Size - Larger wire will carry more current since it has less internal resistance to current flow and generates less heat. The wire also conducts heat away from the connector.
- b) Connector Size - In general, with more circuits in a connector, less current per contact can be carried.
- c) Current Load Distribution - Spreading those lines with greater current loads throughout the connector, particularly around the outer perimeter, will enhance heat dissipation.
- d) Ambient Temperature - With higher ambient temperature, less current can be carried.

Performance Data

Temperature Rating - Phenolic Housings, -55°C to +150°C

Polyester Housings - -55°C to +130°C

Flammability Rating - Phenolic Material, UL 94V-0

Dielectric Withstanding Voltage (at sea level) Type III+ Contacts, 900 VAC, RMS

Durability (Mating/Unmating) - Contacts, Gold plated - 500 cycles; Contacts, Bright tin-lead plated - 50 cycles

Note: For detailed information on the above performance data and further information on other performance data such as Insulation Resistance, Thermal Shock, Moisture Resistance, Vibration and Physical Shock, request AMP Product Specification No. 108-10001.

M Series V.35 Printed Circuit Board Connectors

Right-Angle Receptacle Assembly



Material and Finish

Housing—Flame retardant phenolic or polyester, black

Contacts—Brass, plated:
a) .000030 [0.00076] gold min. in mating area, .000050 [0.00127] nickel min. under-plating overall

Contact Spring—Stainless steel

Contact Post—Brass, tin plated

Mounting Bracket—Brass, tin-nickel plated or zinc, nickel plated

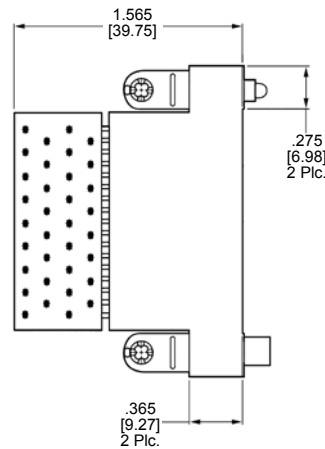

(For Recommended PC Board Hole Pattern see page 65)

Boardlocks—Copper alloy, tin plated

Location Wafer—Phenolic

Nuts and Lockwashers—Steel, zinc plated

Jackscrews—Stainless steel

| No. of Pos. | Mounting Bracket | PCB Dimensions | | Boardlocks | Housing Material | Select Load Pattern | Part Number |
|-------------|--------------------------|----------------|--------------|------------|------------------|---|-------------|
| | | A | B | | | | |
| 34 | Brass, Tin-Nickel Plated | .555 14.10 | * | No | Phenolic | Fully Loaded | 2-212810-0 |
| 14 | | .555 14.10 | * | No | Phenolic | B, C, D, E, F, H, P, R, S, T, V, X, Y, AA | 2-212810-4 |
| 27 | | .555 14.10 | * | No | Phenolic | A, B, C, D, E, F, H, J, P, R, S, T, U, V, W, X, Y, AA, BB, CC, DD, FF, HH, JJ, KK, LL, NN | 2-212810-7 |
| 34 | Zinc, Nickel Plated | .572 14.53 | .347 8.81 | Yes | Phenolic | Fully Loaded | 1-213574-1 |
| 17 | | .572 14.53 | .347 8.81 | Yes | Phenolic | A, B, C, D, E, F, H, P, R, S, T, U, V, W, X, Y, AA | 1-213574-2 |
| 23 | | .572 14.53 | .347 8.81 | Yes | Phenolic | A, B, C, D, E, F, H, J, K, L, N, P, R, S, T, U, V, W, X, Y, AA, BB, NN | 1-213574-3 |
| 22 | | .572 14.53 | .347 8.81 | Yes | Phenolic | A, B, C, D, E, F, H, K, L, N, P, R, S, T, U, V, W, X, Y, AA, BB, NN | 1-213574-4 |
| 22 | | .555 14.10 | .330 8.38 | Yes | Phenolic | A, B, C, D, E, F, H, J, L, N, P, R, S, T, U, V, W, X, Y, AA, HH, NN | 1-213574-5 |

| No. of Pos. | Mounting Bracket | PCB Dimensions | | Boardlocks | Housing Material | Select Load Pattern | Part Number |
|-------------|--------------------------|----------------|--------------|------------|------------------|--|-------------|
| | | A | B | | | | |
| 34 | Brass, Tin-Nickel Plated | .555 14.10 | * | No | Polyester | Fully Loaded | 1-213806-0 |
| 34 | None | — | * | No | Polyester | Fully Loaded | 1-213806-3 |
| 19 | Brass, Tin-Nickel Plated | .555 14.10 | * | No | Polyester | A, B, C, D, E, F, H, J, L, P, R, S, T, U, V, W, X, Y, AA Hardware Supplied Unassembled | 1-213806-1 |
| 18 | None | — | * | — | Polyester | A, B, C, D, E, F, H, K, P, R, S, T, U, V, W, X, Y, AA No Hardware Supplied | 1-213806-2 |
| 34 | Zinc, Nickel Plated | .572 14.53 | .347 8.81 | Yes | Polyester | Fully Loaded | 213977-9 |
| 23 | Zinc, Nickel Plated | .572 14.53 | .347 8.81 | Yes | Polyester | A, B, C, D, E, F, H, J, K, L, N, P, R, S, T, U, V, W, X, Y, AA, BB, NN | 213977-7 |
| 23 | Zinc, Nickel Plated | .572 14.53 | .347 8.81 | Yes | Polyester | A, B, C, D, E, F, H, J, L, N, P, R, S, T, U, V, W, X, Y, AA, HH, KK, NN | 213977-8 |
| 17 | Zinc, Nickel Plated | .572 14.53 | .347 8.81 | Yes | Polyester | A, B, C, D, E, F, H, P, R, S, T, U, V, W, X, Y, AA | 1-213807-0 |

*The mounting bracket has an elongated slot for a 4-40 screw that will accommodate a .330 [8.38] or .347 [8.81] footprint.
Note: Other select loaded configurations can be made available; consult Tyco Electronics Corporation.

M Series V.35 Printed Circuit Board Connectors (Continued)

Right-Angle Plug Assembly



Material and Finish

Housing - Flame retardant phenolic or polyester, black

Contacts—Brass, plated:
a) .000030 [0.00076] gold min. in mating area, .000050 [0.00127] nickel min. under-plating overall

Contact Spring - Stainless steel

Contact Post—Brass, tin plated

Mounting Bracket - Brass, tin-nickel plated or zinc, nickel plated

Boardlocks - Copper alloy, tin plated

Location Wafer Phenolic

Nuts and Lockwashers - Steel, zinc plated

Jackscrews - Stainless steel



Recommended PC Board Hole Pattern
(All dimensions typical)

Note: Pc board layouts and connector dimensions illustrated above serve as a guide only; they are not to be used for actual design or construction of customer equipment. Consult AMP customer drawings for latest detailed pc board layout and connector dimension requirements.

| No. of Pos. | Mounting Bracket | Dimensions | | Boardlocks | Housing Material | Select Load Pattern | Part Number |
|-------------|--------------------------|---------------|--------------|------------|------------------|---------------------|-------------|
| | | A | B | | | | |
| 34 | Brass, Tin Nickel Plated | .555 14.10 | * | No | Phenolic | Fully Loaded | 213289-2 |
| 34 | Zinc, Nickel Plated | .572 14.53 | .347 8.81 | Yes | Phenolic | Fully Loaded | 213513-4 |

*The mounting bracket has an elongated slot for a 4-40 screw that will accommodate a .330 [8.38] or .347 [8.81] footprint.

Note: Other select loaded configurations can be made available; consult Tyco Electronics Corporation.

| No. of Pos. | Mounting Bracket | Dimensions | | Boardlocks | Housing Material | Select Load Pattern | Part Number |
|-------------|---------------------|----------------------|--------------|------------|------------------|---|-------------|
| | | A | B | | | | |
| 34 | Zinc, Nickel Plated | .572 14.53 | .347 8.81 | Yes | Polyester | Fully Loaded | 213808-3 |
| 18 | — | No Hardware Supplied | | | Polyester | A, B, C, D, E, F, H, K, P, R, S, T, U, V, W, X, Y, AA | 213808-4 |

Note: Other select loaded configurations can be made available; consult Tyco Electronics Corporation.

M Series V.35 Printed Circuit Board Connectors (Continued)

Vertical Receptacle Assembly



Material and Finish

Housing - Flame retardant phenolic or polyester, black

Contacts - Brass, plated:
a) .000030 [0.00076] gold min. in mating area, .000050 [0.00127] nickel min. under-plating overall

Contact Spring - Stainless steel

Contact Post - Brass, tin-lead plated

Nuts and Lockwashers - Steel, zinc plated

Spacers - Stainless steel

Jackscrews - Stainless steel

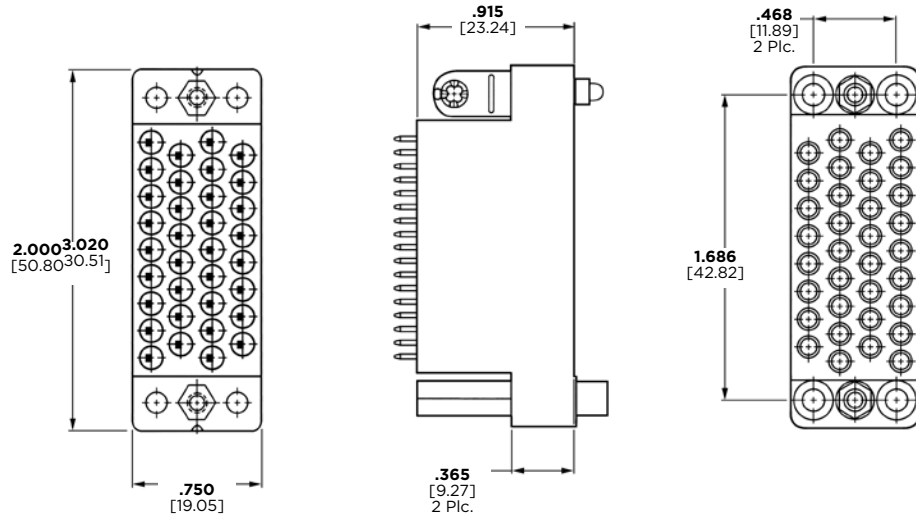

Recommended PC Board Hole Pattern
(All dimensions typical)

Note: Pc board layouts and connector dimensions illustrated above serve as a guide only; they are not to be used for actual design or construction of customer equipment. Consult AMP customer drawings for latest detailed pc board layout and connector dimension requirements.

| No. of Pos. | Mounting Hardware | Housing Material | Select Load Pattern | Part Number |
|-------------|--------------------|-----------------------|--|----------------------|
| 34 | None | Phenolic | Fully Loaded | 213473-3 |
| | Spacers | Phenolic Polyester | Fully Loaded | 213524-8 213809-7 |
| 13 | Nuts & Lockwashers | Phenolic | B, C, D, E, F, P, R, S, T, V, X, Y, AA | 213524-9 |

Note: Other select loaded configurations can be made available; consult Tyco Electronics Corporation.

M Series V.35 Printed Circuit Board Connectors (Continued)

Vertical Plug Assembly



Material and Finish

- Housing** - Flame retardant phenolic, black
- Contacts** - Brass, plated:
a) .000030 [0.00076] gold min. in mating area, .000050 [0.00127] nickel min. under-plating overall
- Contact Spring** - Stainless steel
- Contact Post** - Brass, tin-lead plated
- Nuts and Lockwashers** - Steel, zinc plated
- Spacers** - Stainless steel
- Jackscrews** - Stainless steel



Recommended PC Board Hole Pattern
(All dimensions typical)

Note: Pc board layouts and connector dimensions illustrated above serve as a guide only; they are not to be used for actual design or construction of customer equipment. Consult Tyco Electronics customer drawings for latest detailed pc board layout and connector dimension requirements.

| No. of Pos. | Mounting Hardware | Select Load Pattern | Part Number |
|-------------|-------------------|--|-------------|
| 19 | Spacers* | A, B, C, D, E, F, K, L, N, P, R, S, T, U, V, W, X, Y, AA | 213550-4 |
| 34 | Spacers* | Fully Loaded | 213550-5 |

*Jackscrews and spacers are provided unassembled.
Note: Other select loaded configurations can be made available, consult Tyco Electronics Corporation.

M Series V.35 Cable Connectors

**Cable Connector Kits,
34 Position, Phenolic**



Material and Finish

Housing - Flame retardant phenolic, black

Shield - Anodized aluminum

Screws - Steel, zinc plated

Jackscrews - Stainless steel

Cable Clamp - Steel, nickel plated

Kits include:

- Housing
- One-piece shield
- One-piece turnable jackscrews
- Strain relief clamp
- Mounting screws

Notes:

1. Plug and receptacle connector kits come partially assembled.
2. Plug connector kits are available with long and short shields, (long shield provides pin protection) and two different size cable clamps.
3. Housings are keyed to fix the proper location of the male and female jackscrew as defined by 408-2593.
4. Short shield kits, **Part No. 213753-1** available with all accessories listed above except housing block and jackscrews. Part number for blocks are found on page 47.
5. Pin and socket contacts sold separately. Size 16, Type III+ contacts are listed on page 31.

| Shield Size | Cable Dia. Range | Housing Material | Dimension A | Kit Part Numbers | |
|-------------|--------------------------|------------------|---------------|------------------|----------|
| | | | | Receptacle | Plug |
| Short | .435-.545 11.05-13.83 | Phenolic | 1.53 38.86 | — | 213300-1 |
| Short | .300-.450 7.62-11.43 | Phenolic | 1.53 38.86 | — | 213300-2 |
| Long | .435-.545 11.05-13.83 | Phenolic | 1.97 50.04 | — | 213300-3 |
| Long | .300-.450 7.62-11.43 | Phenolic | 1.97 50.04 | — | 213300-4 |
| Short | .435-.545 11.05-13.83 | Phenolic | 1.53 38.86 | 213522-1 | — |
| Short | .300-.450 7.62-11.43 | Phenolic | 1.53 38.86 | 213522-2 | — |
| Short | .200-.300 5.08-7.62 | Phenolic | 1.53 38.86 | — | 213300-7 |

M Series V.35 Cable Connectors (Continued)

Cable Connector Kits, 34 Position, Polyester (Continued)



Plug



Receptacle



Material and Finish

Housing—Flame retardant polyester, black

Shield—Anodized aluminum

Screws—Steel, zinc plated

Jackscrews—Stainless steel or zinc, nickel plated

Cable Clamp—Steel, nickel plated

Notes:

1. Plug and receptacle connector kits come partially assembled.
2. Two different size cable clamps.
3. Housings are keyed to fix the proper location of the male and female jackscrew as defined by 408-2593.
4. Pin and socket contacts sold separately. Size 16, Type III+ contacts are listed on page 31.

Kits include:

- Housing
- One-piece shield
- One-piece turnable jackscrews
- Strain relief clamp
- Mounting screws

| Packaging | Cable Dia. Range | Housing Material | Jackscrew Type | Kit Part Numbers | |
|------------|---------------------------------|------------------|-----------------|------------------|------------|
| | | | | Receptacle | Plug |
| Bulk | .435-.545 11.05-13.83 | Polyester | Stainless Steel | 213931-1 | — |
| Individual | .300-.450 7.62-11.43 | Polyester | Stainless Steel | 213931-2 | — |
| Individual | .435-.545 11.05-13.83 | Polyester | Zinc | 213931-3 | — |
| Individual | .435-.545 11.05-13.83 | * | Zinc | 213931-4 | — |
| Individual | .300-.450 7.64-11.43 | Polyester | Zinc | 213931-5 | — |
| Bulk | .435-.545 11.05-13.83 | Polyester | Stainless Steel | — | 213932-1 |
| Individual | .300-.450 7.62-11.43 | Polyester | Stainless Steel | — | 213932-2 |
| Individual | .435-.545 11.05-13.83 | Polyester | Zinc | — | 213932-3 |
| Individual | .300-.450 7.62-11.43 | Polyester | Zinc | — | 213932-4 |
| Individual | .300-.450 7.62-11.43 | Polyester | Zinc | — | 213932-5** |

*Housing not included in Kit No. 213931-4

**Long Shield, Assembled Length - 2.060±0.040 [52.32±1.02]

M Series V.35 Cable Connectors (Continued)

Cable Connector Kits, 34 Position, Phenolic
(Continued)

Material and Finish

Housing - Flame retardant phenolic, black

Shield - Zinc, nickel plated

Screws - Steel, zinc plated

Jackscrews - Stainless steel or zinc, nickel plated

Cable Clamp - Steel, nickel plated

Kits include:

- Housing
- Two-piece shield
- One-piece turnable jackscrews
- Two cable clamp inserts
- Mounting screws

Notes:

1. Plug and receptacle connector kits come partially assembled.
2. Plug connector kits are available with or without pin hoods.
3. Housings are keyed to fix the proper location of the male and female jackscrew as defined by 408-2593.
4. Choice of stainless steel or zinc die cast one-piece jackscrews.
5. Pin and socket contacts sold separately. Size 16, Type III+ contacts are listed on page 31.



| Pin Hood | Cable Dia. Range | Jackscrew Type | Kit Part Numbers | |
|----------|--------------------------|-----------------|------------------|------------|
| | | | Receptacle | Plug |
| No | .400-.600 10.16-15.24 | Zinc | — | 213684-1 |
| No | .250-.400 6.35-10.16 | Zinc | — | 213684-2 |
| Yes | .400-.600 10.16-15.24 | Zinc | — | 213684-3 |
| Yes | .250-.400 6.35-10.16 | Zinc | — | 213684-4 |
| No | .400-.600 10.16-15.24 | Stainless Steel | — | 213684-7 |
| No | .400-.600 10.16-15.24 | Zinc | 213685-1 | — |
| No | .250-.400 6.35-10.16 | Zinc | 213685-2 | — |
| No | .400-.600 10.16-15.24 | Stainless Steel | 213685-3 | — |
| No | .150-.300 3.81-7.62 | Zinc | 213685-5 | — |
| Yes | .150-.300 3.81-7.62 | Zinc | — | 213684-9 |
| No | .150-.300 3.81-7.62 | Zinc | — | 1-213684-0 |

M Series V.35 Cable Connectors (Continued)

**Cable Connector Kits,
34 Position, Polyester**
(Continued)

Material and Finish

Housing—Flame retardant polyester, black

Shield—Zinc, nickel plated

Screws—Steel, zinc plated

Jackscrews—Zinc, nickel plated

Cable Clamp—Steel, nickel plated

Kits include:

- Housing
- Two-piece shield
- One-piece turnable jackscrews
- Two cable clamp inserts
- Mounting screws

Notes:

1. Plug and receptacle connector kits come partially assembled.
2. Plug connector kits are available with or without pin hoods.
3. Housings are keyed to fix the proper location of the male and female jackscrew as defined by 408-2593.
4. Pin and socket contacts sold separately. Size 16, Type III+ contacts are listed on page 31.



| Pin Hood | Cable Dia. Range | Kit Part Numbers | |
|----------|---------------------------------|------------------|----------|
| | | Receptacle | Plug |
| No | .150-.300 3.81-7.62 | — | 213803-1 |
| No | .250-.400 6.35-10.16 | — | 213803-2 |
| Yes | .150-.300 3.81-7.62 | — | 213804-1 |
| Yes | .250-.400 6.35-10.16 | — | 213804-2 |
| No | .150-.300 3.81-7.62 | 213805-1 | — |
| No | .250-.400 6.35-10.16 | 213805-2 | — |
| No | .400-.600 10.16-15.24 | — | 213803-3 |
| Yes | .400-.600 10.16-15.24 | — | 213804-3 |
| No | .400-.600 10.16-15.24 | 213805-3 | — |

NOTE: All part numbers are RoHS Compliant

Special Application Connectors

**High Current 12 Position
UL Voltage Rating:
1800 V**

Material and Finish

Housing - Phenolic, 94V-O rated, black

Contacts must be ordered separately.



Recommended Panel Cutout



Plug Housing

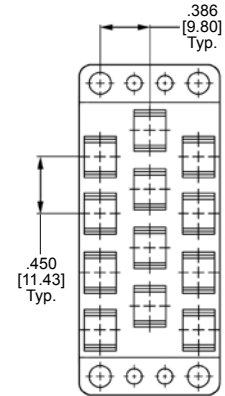

Receptacle Housing

| Phenolic Housing Part No. | | Contacts Accepted | | |
|---------------------------|------------|-------------------|--------------|-----------|
| Plug | Receptacle | Quantity | Contact Type | Page Ref. |
| 205042-1 | 205043-1 | 12 | Type XII | 38, 39 |

Note: 12 position connector uses Standard 75 Position Hardware. Refer to appropriate column of Application Charts for Hardware Selection pages 10 through 25.

Special Application Connectors (Continued)

Mixed 29 CF Position (with Center Fastener)

Material and Finish

Housing - Phenolic, 94V-0 rated, black

Contacts must be ordered separately.



Plug Housing

Recommended Panel Cutout



Receptacle Housing

| Phenolic Housing Part No. | | Contacts Accepted | | |
|---------------------------|------------|-------------------|---------------------------|------------|
| Plug | Receptacle | Quantity | Contact Type | Page Ref. |
| 202479-2 | 202478-2 | 14* | Type II | 30 |
| | | | Type III+ | 31-35 |
| | | | Subminiature COAXICON | 40, 41 |
| | | 12 | Type XII | 38, 39 |
| | | 2 | Standard COAXICON | — |
| | | 1 | Type I Miniature COAXICON | 36, 42, 43 |

*Quantity may be all of the same type, or a combination of those types listed. See Hardware Section for appropriate hardware for this connector. See pages 78-89.

Special Application Connectors (Continued)

Mixed 42 Position

Material and Finish

Housing - Phenolic, black or diallyl phthalate, blue, 94V-0 rated

Contacts must be ordered separately.



Recommended Panel Cutout

Plug Housing

Receptacle Housing

| Phenolic Housing Part No. | | Diallyl Phthalate Housing Part No. | | Contacts Accepted | | |
|---------------------------|------------|------------------------------------|------------|-----------------------|--------------|-----------|
| Plug | Receptacle | Plug | Receptacle | Quantity | Contact Type | Page Ref. |
| 202515-1 | 202516-1 | 202515-3 | 202516-3 | 36* | Type II | 30 |
| | | | | | Type III+ | 31-35 |
| | | | | Subminiature COAXICON | 40, 41 | |
| | | | | 6* | Type I | 36 |
| Miniature COAXICON | 42, 43 | | | | | |

*Quantity may be all of the same type, or a combination of those types listed.
Note: 42 position connector uses Standard 50 Position Hardware. Refer to appropriate column of Application Charts for Hardware Selection pages 10 through 25.

Special Application Connectors (Continued)

High Voltage 20 Position UL Voltage Rating: 1800 V

Material and Finish

Housing - Diallyl phthalate, 94V-O rated, blue

Contacts must be ordered separately.

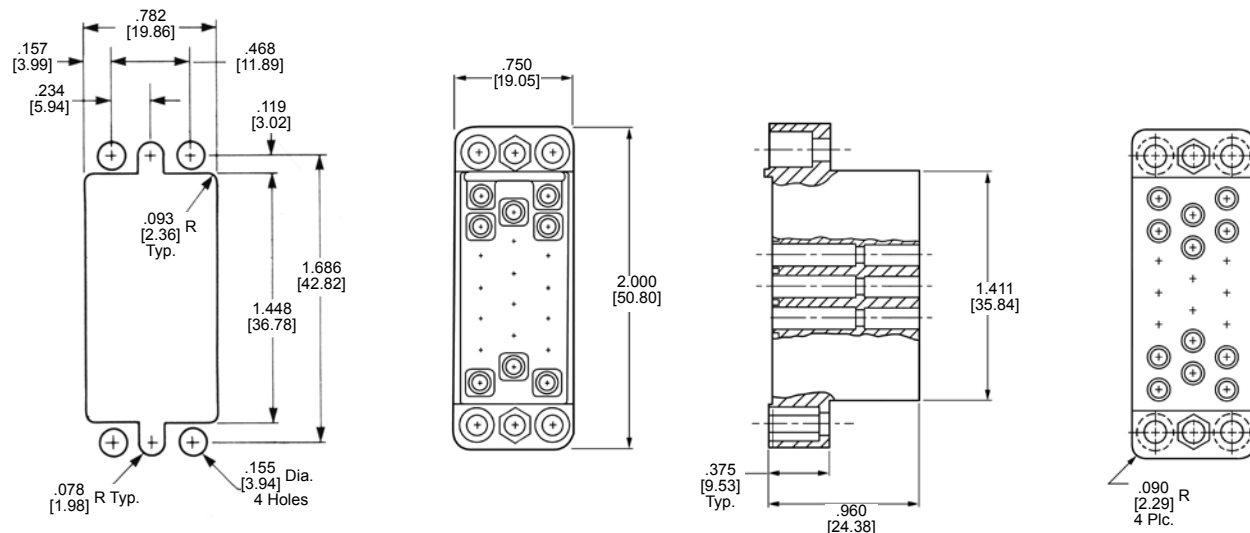

Recommended Panel Cutout

Plug Housing

Receptacle Housing

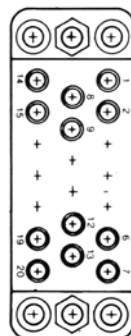

Plug Housing Wiring Side

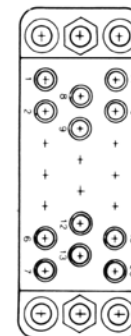

Receptacle Housing Wiring Side

| Diallyl Phthalate Housing Part No. | | Contacts Accepted | | |
|------------------------------------|------------|-------------------|-----------------------|-----------|
| Plug | Receptacle | Quantity | Contact Type | Page Ref. |
| 203908-2 | 203909-2 | 20* | Type II | 30 |
| | | | Type III+ | 31-35 |
| | | | Subminiature COAXICON | 40, 41 |

*Quantity may be all of the same type, or a combination of those types listed.
Note: 20 Position connector uses Standard 34 Position Hardware. Refer to appropriate column of Application Charts for Hardware Selection pages 10 through 25.

Special Application Connectors (Continued)

High Voltage 28 Position UL Voltage Rating: 1800 V

Material and Finish

Housing - Phenolic, 94V-O rated, black

Contacts must be ordered separately.



Plug Housing

Recommended Panel Cutout

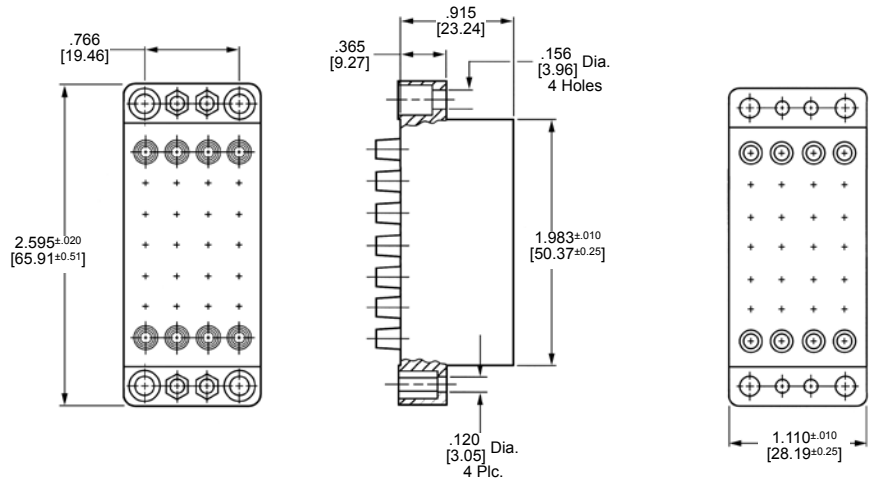

Receptacle Housing

| Phenolic Housing Part No. | | Contacts Accepted | | |
|---------------------------|------------|-------------------|-----------------------|-----------|
| Plug | Receptacle | Quantity | Contact Type | Page Ref. |
| 205689-2 | 205690-2 | 28* | Type II | 30 |
| | | | Type III+ | 31-35 |
| | | | Subminiature COAXICON | 40, 41 |

*Quantity may be all of the same type, or a combination of those types listed.

Note: 28 Position connector uses Standard 75 Position Hardware. Refer to appropriate column of Application Charts for Hardware Selection Pages 10 through 25.

Special Application Connectors (Continued)

Grounding Blocks

Material and Finish

- Plate** - Brass, tin plated
- Clinch Nuts** - Stainless steel
- Pin Contacts** - Phosphor bronze, gold over nickel plated



14-Position, Part No. 203540-1*



34-Position, Part No. 204814-1*



Grounding blocks mate with standard 14 and 34 position receptacle housings.

Note: Use referenced turnable jackscrews on mating housings when mating to grounding blocks.
*CSA Certification pending.

Fastening Hardware - For use in connector housings to mate with grounding blocks

Jackscrews

Material and Finish

- Jackscrew Body** - Die cast zinc, (clear chromate) conversion coating
- Jackscrew Tip, Roll Pin** - Stainless steel



**Short Turnable Jackscrew, Male
Part No. 203618-1
(2 Req'd.)**

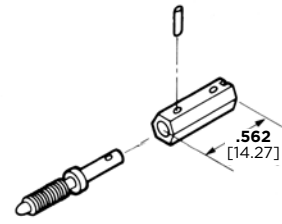

**Short-Short Turnable Jackscrew, Male
Part No. 203535-2
(2 Req'd.)**

Fastening Hardware

Jackscrews

Material and Finish

Turnable Jackscrew Body - Die cast zinc, chromate conversion coating

Turnable Jackscrew Tip - Stainless steel

Roll Pin - Stainless steel

For Fixed Jackscrews

Lockwasher - Steel

Hex Nut - Steel, zinc plated

Jackscrews are used as an aid in mating and unmating connectors and for holding mated connectors together, mostly larger sizes (34-position and up). They can also be used for polarization.

Turnable jackscrews are free to rotate in a connector housing and are always used opposite mating fixed jackscrews. Where provided, roll pins are used to hold a male or female tip onto the turnable jackscrew body. AMP Assembly Tool No. 91016-2 (shown below) is available for properly assembling the turnable jackscrews on a connector housing.

Fixed jackscrews can be readily assembled to a connector housing with the Nut Driver Tool (also shown below).

Turnable Jackscrews



*Assembled dimension includes metal thickness of Pin Hood or Strain Relief Clamp. Remove washer when both Pin Hood and Strain Relief Clamp are used.

Turnable Jackscrews

| Style | Jackscrew Part No. | | Connectors Used on (No. of Positions) | | | | |
|-------------------------------|--------------------------------------|--------------------------------------|---------------------------------------|---------------------------------------|---------------------|---------------|--------------|
| | 6-32 [M3.5 x 0.6] Double Lead Thread | 6-32 [M3.5 x 0.6] Single Lead Thread | Standard | Posted | Special Application | | |
| | | | | | High Current | Mixed | High Voltage |
| Long-Long Male ¹ | 201911-1 | 207234-1 | 50 (90° shield only), 75 and 104 | — | 12 | 42 | 28 |
| Long-Long Female ¹ | 201910-1 | 207235-1 | | | | | |
| Long Male | 1-200871-0 | 201413-4 | 20, 26, 34, 41 and 50 | 20, 26, 34, 41, and 50 | 12 | 15, 16 and 42 | 20 and 28 |
| Long Female | 1-200867-1 | 201414-4 | | | | | |
| Short Male | 200868-1 | 201087-1 | 6, 14, 20, 26, 34, 41, 50, 75 and 104 | 6, 14, 20, 26, 34, 41, 50, 75 and 104 | 12 | 15, 16 and 42 | 20 and 28 |
| Short Female | 200870-1 | 201088-1 | | | | | |
| Short-Short Male | 201388-1 | 201827-1 | 6, 14, 20, 26, 34, 41, 50, 75 and 104 | 6, 14, 20, 26, 34, 41, 50, 75 and 104 | 12 | 15, 16 and 42 | 20 and 28 |
| Short-Short Female | 201389-1 | 201828-1 | | | | | |

¹Long-Long Turnable Jackscrews are used only with Two-Piece Shields on the connector sizes listed.

Notes: 1. Turnable Jackscrews mate with any Fixed Jackscrew listed below having the same thread size.

2. Special Turnable Jackscrews for use in connector housings to mate with Grounding Blocks are presented on page 77.

3. Single-lead versions are designed to mate with competitive Jackscrews.

Roll pins for turnable jackscrews, Long-Long, Long, Short Part No. 201501-1, Short-Short Part No. 201501-2.



**AMP Assembly Tool
Part No. 91016-2
(for Roll Pins)**



**Nut Driver
Part No. 811262-1 (4-40)**

Fastening Hardware (Continued)

Fixed Jackscrews

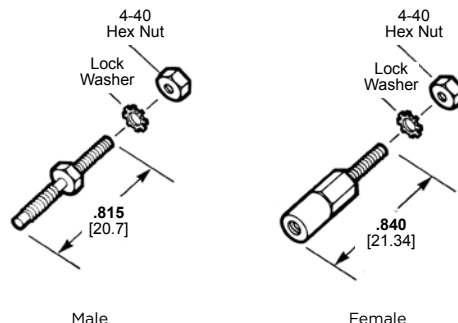

Fixed Jackscrews

| Type | Jackscrew Part No. | |
|--------|--|--|
| | 6-32 [M3.5 x 0.6] Double Lead Thread | 6-32 [M3.5 x 0.6] Single Lead Thread |
| Male | 1-200874-2 | 201092-4 |
| Female | 200875-7 | 201089-4 |

- Notes:**
1. Fixed Jackscrews mate with any Turnable Jackscrew listed above having the same thread size.
 2. Single-lead versions are designed to mate with competitive Jackscrews.
 3. **Double-Lead Thread and Single-Lead Thread Jackscrews can NOT be mixed; i.e., Double-Lead must mate with Double, Single-Lead with Single.**
 4. Double-Lead Thread has two leads in the same revolution versus one lead for Single-Lead Thread. Therefore, Double-Lead Thread will pick up twice as fast.

Fastening Hardware (Continued)

Locking Springs

Material and Finish

Male (Spring Member) -
Spring steel, nickel plated

Female (Latching Member) -
Stainless steel

Locking Springs are used to hold mated connectors together. Although Locking Springs can be used on connectors up to 50 positions, they are primarily used on smaller size connectors (less than 34 positions).

In all applications, a Male (Spring Member) is used opposite a Female (Latching Member). They can be secured to a connector housing using Guide Pins and Sockets or 4-40 x .250 [6.35] fillister head screws and nuts. Locking Springs can be used with all hardware, except Closed-End Pin Hoods.

For Housings with Single Mounting Hole



For Housings with Three Mounting Holes



| Standard Connector Size* | A Max. |
|--------------------------|----------------|
| 6 | 1.413 35.89 |
| 14 | 1.662 42.21 |
| 20 | 1.975 50.17 |
| 26 | 2.037 51.74 |
| 34 | 2.412 61.26 |
| 41 | 3.047 77.39 |
| 50 | 3.006 76.35 |

*A dimension also applies to other comparably sized connector types listed in the chart at the right.

| Locking Spring Part No. | | Connectors Used On (No. of Positions) | | | | |
|-------------------------|--------------------------|---------------------------------------|------------------|---------------------|-----------|--------------|
| Male (Spring Member) | Female (Latching Member) | Standard | Posted | Special Application | | |
| | | | | High Current | Mixed | High Voltage |
| 201921-1 | 201922-1 | 6, 14, 20 and 41 | 6, 14, 20 and 41 | — | — | — |
| 201923-1 | 201918-1* | 26 | 26 | — | 15 | — |
| 201925-1 | 201926-1 | 34 and 50 | 34 and 50 | — | 16 and 42 | 20 |

*Single female latch, two must be ordered per assembly.

Guiding Hardware

Guide Pins and Sockets

Material and Finish

Guide Pins and Sockets—Stainless steel

Lockwashers—Stainless steel

Hex Nuts—Steel, zinc plated

Guiding hardware is used to align connector halves during mating. This hardware can also be used for keying connectors to provide for proper mating. Guiding hardware can be readily secured to connector housings using the Nut Driver shown below.

Center Guide Pins and Sockets are used primarily in housings having a single mounting hole, but can also be used in the centermost hole of housings having 3 or 4 mounting holes.

Corner Guide Pins and Sockets are used in the corner holes of housings having 2, 3 or 4 mounting holes. They cannot be used in center mounting holes which are slightly deeper than corner mounting holes to accept Jackscrews.



Nut Driver
Part No. 811262-1 (4-40)
Part No. 811262-2 (6-32)

| Guide Pins and Sockets Type | Part No. | Connectors Used On (No. of Positions) | | | | |
|--------------------------------|------------------------------------|---------------------------------------|---------------------------------------|---------------------|---------------|--------------|
| | | Standard | Posted | Special Application | | |
| | | | | High Current | Mixed | High Voltage |
| Center Pin | 200389-2 | 6, 14, 20, 26, 34, 41, 50, 75 and 104 | 6, 14, 20, 26, 34, 41, 50, 75 and 104 | 12 | 15, 16 and 42 | 20 and 28 |
| Center Socket | 200390-9 207619-1* ² | | | | | |
| Corner Pin | 1-200833-1 | 34 and 50 | 34 and 50 | — | 16 and 42 | 20 |
| Corner Socket | 1-200835-1 203964-1* | | | | | |
| Corner Pin | 1-201046-2 | 75, 104 and 160 CF | 75, 104 and 160 CF | 12 | 29 | 28 |
| Corner Socket | 201047-2 203966-1* | | | | | |
| Corner Pin | 202173-8 202173-7 ³ | 104 CF | 104 CF | — | — | — |
| Corner Socket | 202174-5 202174-4 ³ | | | | | |
| | 204099-2** | | | | | |
| Long Pin ¹ | 201540-1 | | | | | |

¹Two Long Pins are to be installed in diagonal corners. Use without Guide Sockets.

²Hex Nut Stainless Steel.

³Without Spacer.

* These Corner or Center Guide Sockets (.880 [22.35] long) are to be used when housings are loaded with Subminiature COAXICON contacts.

** Corner Socket, Part No. 204099-2 (.838 [21.29] long), is to be used when housings are loaded with Subminiature COAXICON contacts.

Protective Hardware

Pin Hoods, Internal Open-End and Closed-End

Material and Finish

See charts

Pin Hoods are used to protect pin contacts that protrude from a connector housing.

When contacts are mixed (pins and sockets in both housings), an Internal Pin Hood is used on one housing and an External Pin Hood (page 83) is used on the other housing. Or a Long Shield is used on one housing and an External Pin Hood must be used on the other housing. When a housing is loaded with all pin contacts, an Internal or External Pin Hood may be used—no Pin Hood is required on the mating half.

External Open-End Pin Hoods with flanges (page 83) are used primarily for mounting a connector with pin contacts to a panel.

All Pin Hoods may be secured to connector housings using other appropriate hardware, such as Jackscrews and Guide Pins and Sockets.



Internal Open-End



Internal Closed-End

Note: Typical Internal Open-End and Closed-End Pin Hoods are illustrated. Slight differences in configuration exist for various sizes. The mounting holes and/or slots in each Pin Hood match the mounting hole pattern of the connector housing on which the Pin Hood is used.

Pin Hoods, Internal Open-End

| Dimensions | | | Material | Pin Hood Part No. | Connectors Used On (No. of Positions) | | | | |
|-----------------------|----------------------|----------------------|---------------------|-------------------|---------------------------------------|--------------|---------------------|--------------|----|
| A | B | C | | | Standard | Posted | Special Application | | |
| | | | | | | High Current | Mixed | High Voltage | |
| 1.000 25.4 | .500 12.7 | .718 18.24 | Nickel Plated Steel | 204258-6 | 6 | 6 | — | — | — |
| 1.250 31.75 | .550 13.97 | .718 18.24 | Nickel Plated Steel | 201363-4 | 14 | 14 | — | — | — |
| 1.632 41.45 | .725 18.42 | .718 18.24 | Nickel Plated Steel | 201785-4 | 26 | 26 | — | 15 | — |
| 2.000 50.8 | .880 22.35 | .718 18.24 | Nickel Plated Steel | 201786-4 | 34 | 34 | — | 16 | 20 |

Pin Hoods, Internal Closed-End

| Dimensions | | | Material | Pin Hood Part No. | Connectors Used On (No. of Positions) | | | | |
|-----------------------|-----------------------|----------------------|---------------------|-------------------|---------------------------------------|--------------|---------------------|--------------|----|
| A | B | C | | | Standard | Posted | Special Application | | |
| | | | | | | High Current | Mixed | High Voltage | |
| 2.130 54.1 | .880 22.35 | .687 17.45 | Nickel Plated Steel | 202434-4 | 34 | 34 | — | 16 | 20 |
| 2.875 73.02 | .952 24.18 | .687 17.45 | Nickel Plated Steel | 202394-2 | 50 | 50 | — | 42 | — |
| 2.765 70.23 | 1.310 33.27 | .687 17.45 | Nickel Plated Steel | 201369-4 | 75 | 75 | 12 | — | 28 |
| 2.975 75.57 | 1.740 44.2 | .687 17.45 | Nickel Plated Steel | 201364-4 | 104 | 104 | — | — | — |
| 2.975 75.57 | 2.040 51.82 | .687 17.45 | Nickel Plated Steel | 203743-4 | 160 CF | 160 CF | — | — | — |

Protective Hardware (Continued)

Pin Hoods, External Closed-End and Open-End (with Flanges)

Material and Finish

See charts



External Closed-End



External Open-End with Flanges

Note: Typical External Closed-End and Open-End (with Flanges) Pin Hoods are illustrated. Slight differences in configuration exist for various sizes. The mounting holes and/or slots in each Pin Hood match the mounting hole pattern of the connector housing on which the Pin Hood is used.

Pin Hoods, External Closed-End

| Dimensions | | | Material | Pin Hood Part No. | Connectors Used On (No. of Positions) | | | | |
|-----------------------|-----------------------|----------------------|---------------------|-------------------|---------------------------------------|--------------|---------------------|--------------|----|
| A | B | C | | | Standard | Posted | Special Application | | |
| | | | | | | High Current | Mixed | High Voltage | |
| 1.880 47.75 | .812 20.62 | .687 17.45 | Aluminum Iridite | 201349-2 | 26 | 26 | — | 15 | — |
| 2.250 57.15 | 1.000 25.4 | .687 17.45 | Aluminum Iridite | 201350-2 | 34 | 34 | — | 16 | 20 |
| 2.845 72.26 | 1.000 25.4 | .687 17.45 | Nickel Plated Steel | 201390-5 | 50 | 50 | — | 42 | — |
| 2.845 72.26 | 1.360 34.54 | .687 17.45 | Nickel Plated Steel | 201368-4 | 75 | 75 | 12 | 29 | 28 |
| 3.025 76.84 | 1.800 45.72 | .687 17.45 | Nickel Plated Steel | 201346-4 | 104 | 104 | — | — | — |
| 3.040 77.22 | 1.340 34.04 | .718 18.24 | Nickel Plated Steel | 202119-2 | 104 CF | 104 CF | — | — | — |
| 3.025 76.84 | 2.100 53.34 | .687 17.45 | Nickel Plated Steel | 203744-4 | 160 CF | 160 CF | — | — | — |

Pin Hoods, External Open-End with Flanges

| Dimensions | | | Material | Pin Hood Part No. | Connectors Used On (No. of Positions) | | | | |
|-----------------------|----------------------|----------------------|---------------------|-------------------|---------------------------------------|--------------|---------------------|--------------|----|
| A | B | C | | | Standard | Posted | Special Application | | |
| | | | | | | High Current | Mixed | High Voltage | |
| 2.875 73.02 | .891 22.63 | .687 17.45 | Nickel Plated Steel | 202095-5 | 34 | 34 | — | 16 | 20 |
| 3.375 85.73 | .565 14.35 | .687 17.45 | Nickel Plated Steel | 202165-5 | 41 | 41 | — | — | — |
| 3.468 88.09 | .891 22.63 | .687 17.45 | Nickel Plated Steel | 202096-5 | 50 | 50 | — | 42 | — |

Protective Hardware (Continued)

Shields, Two-Piece, 180° and 90° Cable Exit

Material and Finish

Shields - See charts

Cable Clamp - Steel, nickel plated

Screws - Steel, zinc plated

These Two-Piece Shields are used to protect connectors from dust, dirt and physical damage and to provide strain relief for the contacts. They feature integral cable clamps formed at 180° and 90° and are available in long and short versions. Long versions offer pin protection as well as connector protection and strain relief. Short versions may be used in combination with Pin Hoods to provide pin protection.

For shielding and fastening applications, Two-Piece Shields are used with Jackscrews. They may be secured to a connector housing using other appropriate hardware such as Guide Pins and Sockets.

Two-Piece Shields with cable clamps formed at 45° are available, see page 87.

Tyco Electronics does **NOT** recommend the use of shields with posted connectors because of the potential of shorting.



180° Cable Exit



90° Cable Exit

Protective Hardware (Continued)

Two-Piece Shields, 180° Cable Exit (Long and Short)

| Dimensions | | | | Material | Shield Part No. | | Max. Cable Dia. | Connectors Used On (No. of Positions) | | | |
|----------------|----------------|----------------|----------------|-----------------------------|-----------------|----------|-----------------|---------------------------------------|---------------------|-------|--------------|
| A | B | C | D | | Long | Short | | Standard | Special Application | | |
| | | | | | | | | | High Current | Mixed | High Voltage |
| .520 13.21 | 1.562 39.67 | 1.815 46.10 | 1.300 33.02 | Nickel Plated Steel | — | 204087-1 | .375 9.53 | 20 | — | — | — |
| | | | | Anodized Aluminum | 201576-1 | — | | | | | |
| .640 16.26 | 1.625 41.28 | 2.453 62.31 | 1.970 50.04 | Nickel Plated Steel | 201576-2 | — | .415 10.54 | 26 | — | 15 | — |
| | | | | Nickel Plated Steel | — | 200514-2 | | | | | |
| | | | | Anodized Aluminum | 201571-1 | — | | | | | |
| .828 21.03 | 2.000 50.8 | 2.453 62.31 | 1.937 49.2 | Nickel Plated Steel | 201571-2 | — | .500 12.7 | 34 | — | 16 | 20 |
| | | | | Anodized Aluminum | — | 200517-1 | | | | | |
| | | | | Nickel Plated Steel | — | 200517-9 | | | | | |
| .515 13.08 | 2.687 68.25 | 2.453 62.31 | 1.968 49.99 | Nickel Plated Steel | 202383-2 | — | .435 11.05 | 41 | — | — | — |
| | | | | Nickel Plated Steel | — | 202383-1 | | | | | |
| | | | | Anodized Aluminum | 201443-1 | — | | | | | |
| .828 21.03 | 2.593 65.86 | 2.468 62.69 | 1.970 50.04 | Nickel Plated Steel | 201443-2 | — | .550 13.97 | 50 | — | 42 | — |
| | | | | Anodized Aluminum | — | 200532-1 | | | | | |
| | | | | Nickel Plated Steel | — | 200532-2 | | | | | |
| 1.195 30.35 | 2.727 69.27 | 3.327 84.51 | 2.797 71.04 | Nickel Plated Steel | 202713-2 | — | 1.000 25.4 | 75 | 12 | — | 28 |
| | | | | Nickel Plated Steel | — | 202713-1 | | | | | |
| 1.703 43.26 | 2.765 70.23 | 1.843 46.81 | 1.290 32.77 | Nickel Plated Cast Aluminum | — | 201131-1 | .800 20.32 | 104 | — | — | — |

Two-Piece Shields, 90° Cable Exit (Long and Short)

| Dimensions | | | | Shield Part No. | | Max. Cable Dia. | Connectors Used On (No. of Positions) | | | | |
|----------------|----------------|----------------|----------------|-----------------|----------|-----------------|---------------------------------------|---------------------|--------------|-------|--------------|
| A | B | C | D | Long | Short | | Standard | Special Application | | | |
| | | | | | | | | | High Current | Mixed | High Voltage |
| .900 22.86 | 2.592 65.84 | 3.098 78.69 | 2.797 71.04 | 203975-2 | — | .550 13.97 | 50 | — | 42 | — | |
| | | | | — | 203975-1 | | | | | | |
| 1.195 30.35 | 2.730 69.34 | 3.260 82.80 | 2.797 71.04 | 202711-3 | — | 1.000 25.4 | 75 | 12 | — | 28 | |
| | | | | — | 202711-1 | | | | | | |
| 1.145 29.08 | 2.845 72.26 | 3.375 85.73 | 2.375 60.33 | — | 202395-1 | 1.000 25.4 | 104 CF | — | — | — | |

Notes: 1. All parts are packaged unassembled.
2. Material: nickel plated steel.

Protective Hardware (Continued)

Shields, One-Piece, 180° and 90° Cable Exit

Material and Finish

Shields and Cable Clamps - Steel, nickel plated

Screws - Steel, zinc plated

One-Piece Shields are used to protect connectors from dust, dirt and physical damage and to provide strain relief for the contacts. They feature integral cable clamps formed at 180° and 90° and are available in long and short versions. Long versions offer pin protection as well as connector protection and strain relief. Short versions may be used in combination with Pin Hoods to provide pin protection.

For shielding and fastening applications, One-Piece Shields are used with Locking Springs. They cannot be used with Jackscrews.

One-Piece Shields may be secured to a connector housing using other appropriate hardware such as Guide Pins and Sockets.

Tyco Electronics does **NOT** recommend the use of shields with posted connectors because of the potential of shorting.



180° Cable Exit

90° Cable Exit

Note: Typical 180° and 90° Cable Exit Shields are illustrated. Slight differences in configuration exist for various sizes.

One-Piece Shields, 180° Cable Exit (Long and Short)

| Dimensions | | | | Shield Part No. | | Max. Cable Dia. | Connectors Used On (No. of Positions) | | |
|----------------------|-----------------------|--------------|--------------|-----------------|----------|----------------------|---------------------------------------|---------------------|--------------|
| A | B | C | D | Long | Short | | Standard | Special Application | |
| | | | | | | | | Mixed | High Voltage |
| | | 2.468 | 1.969 | 201378-2 | — | .375 9.53 | 14 | — | — |
| .531 13.49 | 1.312 33.32 | 62.69 | 50.01 | — | 201360-2 | | | | |
| | | 1.796 | 1.300 | — | 201227-2 | .350 8.89 | 20 | — | — |
| .515 13.08 | 1.640 41.66 | 45.62 | 33.02 | — | 201169-2 | | | | |
| | | 1.796 | 1.296 | — | 201169-2 | .400 10.16 | 26 | 15 | — |
| .640 16.26 | 1.687 42.85 | 45.62 | 32.92 | — | 201165-2 | | | | |
| | | 2.468 | 1.969 | 201384-2 | — | .500 12.7 | 34 | 16 | 20 |
| .828 21.03 | 2.062 52.37 | 62.69 | 50.01 | — | 201165-2 | | | | |
| | | 1.781 | 1.281 | — | 201165-2 | | | | |
| | | 45.24 | 32.54 | | | | | | |

One-Piece Shields, 90° Cable Exit (Short)

| Dimensions | | | | Shield Part No. | Max. Cable Dia. | Connectors Used On (No. of Positions) | | |
|----------------------|-----------------------|--------------|--------------|-----------------|---------------------|---------------------------------------|---------------------|----|
| A | B | C | D | Short | | Standard | Special Application | |
| | | | | | | Mixed | High Voltage | |
| | | 2.562 | 1.812 | 201469-2 | .500 12.7 | 34 | 16 | 20 |
| .828 21.03 | 2.062 52.37 | 65.07 | 46.02 | | | | | |

Note: All parts are packaged unassembled.

Protective Hardware (Continued)

**Shields, Two-Piece,
45° and 30° Cable Exit**

Material and Finish

Shields and Cable Clamps -

Steel, nickel plated

Screws - Steel, zinc plated

These Two-Piece Shields are used to protect connectors from dust, dirt and physical damage and to provide strain relief for the contacts. They feature integral cable clamps formed at 45° and are specifically designed for use with 104 CF and 160 CF position standard connectors; 30° exit shield is available for 29 CF position connectors.

These Shields may be used with Pin Hoods to provide pin protection.

These Two-Piece Shields may be secured to a connector housing using other appropriate hardware such as Guide Pins and Sockets.

Tyco Electronics does **NOT** recommend the use of shields with posted connectors because of the potential of shorting.

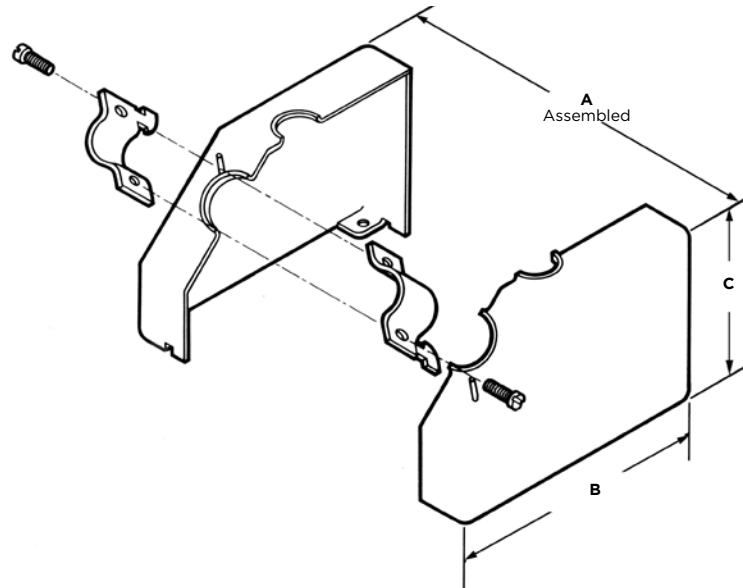

45° Cable Exit

Note: A typical 45° Cable Exit Shield is illustrated. Slight differences in configuration exist between sizes.

Two-Piece Shields, 45° Cable Exit

| Dimensions | | | Shield Part No. | Max. Cable Dia. | Connectors Used On (No. of Positions) Standard |
|-----------------------|-----------------------|-----------------------|-----------------|-----------------------|--|
| A | B | C | | | |
| 1.145 29.08 | 2.845 72.26 | 2.375 60.33 | 202169-4 | 1.000 25.4 | 104 CF |
| | | 1.875 47.63 | 202110-1 | .650 16.51 | |
| 1.845 46.86 | 2.770 70.36 | 2.750 69.85 | 202798-1 | 1.200 30.48 | 160 CF |

Note: All parts are packaged unassembled.

Two-Piece Shield, 30° Cable Exit

| Dimensions | | | Shield Part No. | Max. Cable Dia. | Connectors Used On (No. of Positions) Standard |
|-----------------------|-----------------------|-----------------------|-----------------|-----------------------|--|
| A | B | C | | | |
| 1.375 34.93 | 2.685 68.19 | 3.440 87.38 | 202483-3 | 1.250 31.75 | 29 CF |

Strain Relief Hardware

Strain Relief Clamps

Material and Finish

- Clamp**—Steel, nickel plated
- Hex Nuts**—Steel, zinc plated
- “U” Bolt**—Stainless steel
- Sleeves**—Black plastic
- Bracket**—See chart

Strain Relief Clamps are used to relieve the stress of the wires on the contacts and to group the wires where they enter a connector. Both long and short versions are available. The long versions are normally used for all applications and provide a greater distance between the wire bundle and the connector for operating Jackscrews without interference. The short versions are ideally suited for applications where space is limited.

Tyco Electronics does **NOT** recommend the use of Strain Relief Clamps with posted connectors because of the potential of shorting.

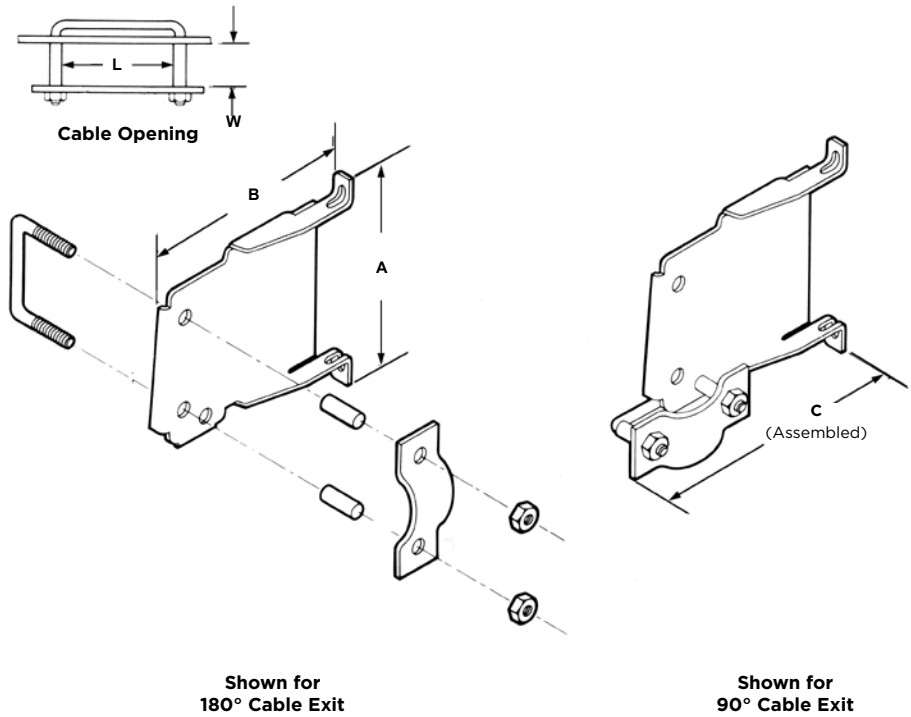

Note: A typical Strain Relief Clamp is illustrated. Slight differences in configuration exist for various sizes.

Cable Clamps (Long and Short)

| Bracket Material | Dimensions | | | Cable Opening L x W | Strain Relief Clamp Part No. | | Connectors Used On (No. of Positions) | | | |
|----------------------|-----------------------|-----------------------|-----------------------|---------------------------------------|------------------------------|----------|---------------------------------------|--------------|-------|--------------|
| | A | B | C | | Long | Short | Standard | High Current | Mixed | High Voltage |
| Steel, Nickel Plated | 1.000 25.4 | 1.125 28.58 | — | .305 x .155 7.75 x 3.94 | — | 203432-1 | 6 | — | — | — |
| | 1.250 31.75 | 2.125 53.98 | 2.687 68.25 | .530 x .335 13.46 x 8.51 | 201843-3 | — | 14 | — | — | — |
| | | 1.125 28.58 | 1.687 42.85 | | — | 200686-4 | — | — | — | — |
| Stainless Steel | 1.562 39.67 | 1.187 30.15 | 2.000 50.8 | .780 x .335 19.81 x 8.51 | — | 201237-2 | 20 | — | — | — |
| Steel, Nickel Plated | 1.625 41.28 | 2.125 53.98 | 2.937 74.6 | .780 x .505 19.81 x 12.83 | 201845-2 | — | 26 | — | 15 | — |
| | | 1.250 31.75 | 2.062 52.37 | .780 x .430 19.81 x 10.92 | — | 201229-5 | — | — | — | — |
| | 2.000 50.8 | 1.500 38.1 | 2.265 57.33 | .780 x .425 19.81 x 10.8 | — | 201224-7 | 34 | — | 16 | 20 |
| Stainless Steel | 2.625 66.68 | 2.000 50.8 | 3.343 84.91 | 1.500 x .360 38.1 x 9.14 | 201766-1 | — | 41 | — | — | — |
| | 2.593 65.86 | 2.406 61.11 | 3.296 83.72 | 1.125 x .675 28.58 x 17.15 | 201847-1 | — | 50 | — | 42 | — |
| Steel, Nickel Plated | 2.562 65.07 | 1.703 43.26 | 2.780 70.61 | 1.125 x .550 28.58 x 13.97 | — | 201182-4 | — | — | — | — |
| Stainless Steel | 2.594 65.89 | 2.531 64.29 | 3.717 94.41 | 1.125 x .925 28.58 x 23.5 | 201848-5 | — | 75 | 12 | — | 28 |
| Steel, Nickel Plated | 2.625 66.68 | 1.734 44.04 | 2.874 73.0 | 1.125 x .800 28.58 x 20.32 | — | 200730-4 | — | — | — | — |
| | 2.750 69.85 | 2.531 64.29 | 3.389 86.08 | 1.125 x 1.235 28.58 x 31.37 | 201849-3 | — | 104 | — | — | — |

Notes: All parts are packaged unassembled.

Keying Hardware

Keying Plug (for Multimate Contact Cavities)

Material

Natural color nylon

This cylindrical keying plug is used in Multimate contact cavities that accept Type II, Type III+ and Subminiature COAXICON socket contacts. The plug protrudes from the mating face of a connector and will prevent connector halves from being mated by butting against the pin contact. The mating pin contact must be removed to provide for proper mating.



Part No. 200821-1



Part No. 207597-1

Keying Plugs (for Type XII Contact Cavities)

Material

For 207597-1—Gray nylon

For 206508-1—Natural color nylon

Two versions of rectangular keying plugs are available for Type XII contact cavities. A pin style is used in cavities that accept Type XII male contacts, and a plug style is used in cavities that accept Type XII female contacts. These keying plugs perform the same as the cylindrical keying plug described above. The mating contact must also be removed to provide for proper connector mating.



Part No. 206508-1

Application Tooling

Mechanical Hand Tools for Interchangeable Die Sets

These tools are ideal for small production, prototype and experimental applications. They are used for terminating pin and socket contacts to wire and feature a ratchet device to provide consistently formed crimps.

SDE (Standard Die Envelope) Die Sets



SDE die sets provide cost-effective flexibility, through many options for a common die-set outline. The SDE die sets can be adapted for use with CERTI-CRIMP hand tools, PRO-CRIMPER III hand tools, the SDE Terminator and the 626 Pneumatic Tool System.

For more information, request Catalog **1654003**.

PRO-CRIMPER III Hand Tool, Part No. 58495-1



Commercial grade hand tool for crimping various products. Features ratchet control to provide complete crimp cycle. Accepts both pinned- and shouldered-style die sets. Locators are provided with pinned-style die sets for proper contact and wire positioning, and to help minimize contact rotation and bending during crimping. Approximate weight 1.3 lb [0.60 kg].

For use with Type III+ contacts, see pages 17-19. For more information, request Catalog **1773379-1**, Instruction Sheet **408-9930**.

CERTI-CRIMP Straight Action Hand Tools (SAHT)



172076

Premium grade hand tools. Feature ratchet control to provide complete crimp cycle. Die sets close in a straight line. Include a contact locator and wire stop, plus an insulation crimp adjustment lever, when applicable. Approximate weight 1.3 lb [0.59 kg].

For Type III+ contacts, see pages 17-19. For more information, request Catalog **65780**.

CERTI-CRIMP "C" Head Straight Action Hand Tool (SAHT), Part No. 69710-1



920648

Premium grade hand tool. Features ratchet control to provide complete crimp cycle. The interchangeable die sets close in a straight line to minimize contact or terminal rotation during crimping. When applicable, user-assist features such as a contact or terminal locator and a wire stop, are built into the die set. Approximate weight 1.9 lb [0.86 kg].

For subminiature coaxial contacts, see pages 22-23. For more information, request Catalog **65780**, Instruction Sheet 408-2095.

Electric Machine for Interchangeable Die Sets

SDE Terminator, Part No. 1490076-2



112869

An electric crimp terminator with compact design features a die set holder that is compatible with all AMP SDE (PRO-CRIMPER III Tool) die sets. Hand- or foot-actuated options are available. CE Approved.

For more information, request Catalog **1654714**.

Application Tooling (Continued)

Pneumatic Hand Tool for Interchangeable Die Sets

6-26 Pneumatic Tool System



Effortless crimping for a broad range of terminals, either bench-mounted or hand-held for working in cramped quarters.

- Lightweight tool eliminates physical force required by hand tools
- Hand- or foot-switch operation
- Termination wire range from 26-6 AWG [0.12-13.0mm²], plus coaxial

and fiber optic cable

- Works with existing AMP-compatible crimp heads and die sets
- Ratchet control option provides complete crimp cycle, eliminating partial crimps
- Use rotating head assembly to reach difficult termination locations

For more information, request Catalog **124208**.

Battery-Powered Crimp Tool Kits



The Battery-Powered Crimp Tool Kit is a fast, ergonomically-designed tool is ideal for use at the bench, on the line, or in the field. It's completely portable, lightweight (3.48 lbs including battery) and compact. The charge delivers over 100 crimps - charge time is 40 mins. The kit includes the tool, 2 batteries and the charger.

P/N 1213890-1 — SDE Battery Powered Crimp Tool Kit (dies not included)

P/N 1213805-1 — CERTI-CRIMP II, SA Battery Powered Crimp Tool Kit (heads not included)

P/N 1213840-1 — CERTI-CRIMP, Large Die, C-Head Adapter Battery Powered Crimp Tool Kit (dies not included)

P/N 1213819-1 — CERTI-CRIMP, Large Die, Straight-Action Adapter Battery Powered Crimp Tool Kit (dies not included)

For more information, request Catalog **1773381**.

CRIMP MACHINES

AMP-O-LECTRIC Model "G" Terminating Machines, Part Nos. 354500-1, -9, -11



Semiautomatic bench machines for crimping reeled terminals and contacts, featuring a quiet and reliable direct motor drive, microprocessor controls for ease of setup and operation, and guarding and lighting designed for operator convenience and safety. All models are equipped with either manual or automatic precision adjustment of crimp height. Machine-mounted sensors are available for crimp quality monitoring using conventional miniature-style applicators.

For more information, request Catalog **1654956-2**, Video **198116**, Catalog **82275 [Crimp Quality Monitor (CQM)]**, Video **198094**.

Note: New Stripping Module available, see page 79.

AMP-TAPETRONIC Machine, Part No. 69875



AMP-O-LECTRIC Model "K" Terminating Machine with a permanently-mounted applicator that accepts interchangeable die sets to apply a variety of tape-mounted terminals and splices. Many of the die sets can also be used in AMP-O-LECTRIC Terminating Machines with a tape applicator.

For more information, contact Tyco Electronics.

Application Tooling (Continued)

Crimp Quality Monitor (CQM)

Part No. 1320420-2



The unique system provides 100% on-the-fly crimp inspection. It measures the crimp height of each termination, and evaluates the quality of each crimp. If a crimp is questionable, the monitor alerts the operator with both visual and audible alarms. It also provides ports for printing and networking. When used with AMP-O-LECTRIC Model "G" Termination Machines, the monitor is mounted to the machine. When used with AMPOMATOR CLS IV Lead Making Machines, it is integrated into the machine's operating system.

For more information, request Catalog **82275**.

AMP 3K/40 and AMP 5K/40 Terminating Machines



The AMP 3K/40 and AMP 5K/40 Terminators are designed for customers that require the increased output and quality of a semiautomatic machine at a competitive price. By incorporating the most commonly requested features as standard and offering a long list of optional equipment, these terminators offer flexibility to meet the specific needs of various applications at the lowest possible cost.

Features

- 3,000 lb [1361 kg] max. crimp force (AMP 3K/40);
- 5,000 lb [2268 kg] max. crimp force (AMP 5K/40)
- Toolless removal of applicators and guards
- Jog capability
- Quiet, fast operation - 80/76 dBA and cycle time less than 0.400 seconds
- Accepts Heavy Duty Mini style applicators
- Wide range of optional equipment such as toolless precision crimp height adjust, batch counter, CQM capability and work light

For more information, request Catalog **1654956-2**.

Note: New Stripping Module available, see page 79.

Crimp Force Monitor (CFM)



Your Quality Program calls for more than a Good Crimping System. It demands proof — the proof you get with the SLE crimp force monitor. It has high-resolution piezo-quartz sensor technology for a more precise identification of typical crimping faults.

Sure, you can sample and test crimp height with a micrometer. In fact, that's how you standardize your process. But for ongoing quality control, testing every crimp, SLE is the choice.

It's known worldwide, and meets our standards or a high performance terminating system. That's how you can be sure.

High quality crimping — with verification — means higher production and productivity.

Features

- 1 or 2 Channels
- 128 x 128 Dot Matrix
- Zone & Peak Force Analysis
- Force Trigger
- Encoder Proximity Trigger
- Absolute Force Measurement
- Monitors the wire barrel crimp of open-barrel, uninsulated contacts and terminals
- Real-time monitoring of every crimp
- Special applicators are not required
- Use with the AMP-3K/40 and AMP-5K/40 presses from Tyco Electronics
- Frame-mounted force sensor
- For bench or fully-automatic machines
- Please contact us for any other type of press you would like to use with the CFM

Crimp Force Monitor Specifications

- Electrical: 110-230 VAC Single Phase, 50-60 Hz, 15 watts
- Size (Monitor): 178mm x 137mm x 95mm
- Weight (Monitor): 1.02kg (single channel), 1.05kg (double channel)

For more information, request Catalog **1309085-2**

System III Applicator



The System III Applicator introduces several new technologies into the applicator including a precision servo-electric motorized feeding system, a built-in data module for storing terminal crimp and set-up information, a precision fit round ram, and a newly designed terminal depressor. It still utilizes the proven quality of the HD-M crimper and anvil tooling.

For more information, request Catalog **1654956-8**

Application Tooling (Continued)

LEAD MAKERS

Komax gamma 333 PC Lead-Making Machine



This fully-automatic, PC-controlled leadmaker can be equipped with up to three processing stations enabling the crimping of both ends of the wire, double-crimp connections with three different contacts, single-ended seal applications, tinning or ink-jet marking. Features include ultra-short conversions times, easy-to-use graphic-based TopWin interface with multiple-language capability, crimp force analyzer with statistical analysis, seal monitoring, and integrated good/bad sorting.

For more information, request Catalog **1307901**.

AMPOMATOR System III Leadmaker



The AMPOMATOR System III Leadmaker is designed for the demands of low-volume/high mix manufacturing and precision quality. This leadmaker combines the best wire processing capabilities with new technologies in terminal feeding and machine set-up found in the System III Applicator to offer significant advantages for higher throughput and efficiencies.

For more information, request Catalog **1654956-5**

Komax 433-S alpha Lead-Making Machine



The 433-S alpha offers maximum flexibility for applying seals to one or both ends of the wire with the corresponding terminal. When equipped with the mci 711 crimp terminator and mci 761 seal applicator, the fully-automated 433-S alpha forms a highly compact system with optimum accessibility. Dynamic servo-drives provide fine travel settings on all motor axes and the wire straightening unit with quick-release lock and automatic lead-in feature reduces wire changeover time. The TopWin software provides for fast, simple data input.

For more information, request Catalog **1307801**.

APPLICATORS

End-Feed Heavy-Duty Miniature Applicators (coded HDM)



Interchangeable applicators for crimping products reeled end-to-end (primarily open-barrel terminals). Used in bench and lead-making machines; most designs can be used, or adapted for use with minor tooling changes, dial-in settings for different wire sizes and insulation diameters. Mechanical or air-powered feed systems, depending on the product applied.

For more information, request Catalog **296393-2** and Instruction Sheet **408-8039**.

EDGE Applicator Counter



The new EDGE counter tracks wearable tool usage for the most effective maintenance planning. The completely electronic counter, with clear LCD display, indicates cycles since installation. By performing maintenance at measured intervals with pre-set limits, operators avoid breakdowns and rejects caused by tool wear or mis-adjustment. A wireless interface transfers counters to a PC running the optional Edge Counter Software Pack.

The EDGE is standard on all new applicators and can be retrofitted to most existing Tyco Electronics applicators.

For more information, request Catalog **1773385**.

Side-Feed Heavy-Duty Miniature Applicators (coded HDM)



Interchangeable applicators for crimping products reeled side-by-side on single or dual carrier strips (primarily closed-barrel terminals and open-barrel contacts). Similar design as the end-feed version. All side-feed applicators include a wire stop to help correctly position the wire end in the crimping target area.

For more information, request Catalog **296393-2** and Instruction Sheet **408-8040**.

Application Tooling (Continued)

Stripper-Crimper Applicators (coded SCA)



Interchangeable applicators for crimping products in AMP-O-MATIC Stripper-Crimper Machines. Consist of separate ram and lower tooling assemblies. Similar dial-in settings for different wire sizes and insulation diameters as HDM applicators. Available with sensors for use with the Crimp Quality Monitor.

For more information, request Catalog **65004 (AMP-O-MATIC Stripper-Crimper Machines)**, Catalog **82275 [Crimp Quality Monitor (CQM)]**.

Cosmic 30M Wire Stripping Machine, 5-528367-0



The Cosmic 30M is a high precision, high speed electrical wire stripper that is very easy to operate. It's equipped with a four blade system and an optional gripper for more difficult wires. There is a digital display for the wire diameter that can be set at 0.01 mm increments.

For more information, request Catalog **1773385-2**.

Cosmic 927R Micro-Cable Stripper



The compact, lightweight, benchtop Cosmic 927R was designed and developed to reliably strip various insulation materials and micro-cable. From conductor diameter 36 to 10 AWG, the stripping diameter display can be set to within 0.1 mm increments.

For more information, request Catalog **1773385-4**.

STRIPPER-CRIMPER MACHINES

AMP-O-MATIC Stripper-Crimper Machines, Part Nos. 1320895-1, -2



Semiautomatic bench crimping machines that also strip the wire, and are therefore used for terminating jacketed cable. Feature manual precision adjustment of crimp height, keyed strip blades for faster, more accurate setups, and an efficient scrap removal system. All adjustments can be made from the front of the machines without special tools. Available with crimp quality monitoring.

For more information, request Catalog **65004**, Video **198075**, Catalog **82275 [Crimp Quality Monitor (CQM)]**, Video **198094**.

Stripping Module (for the AMP 3K/40 and AMP 5K/40 Terminating Machines and AMP-O-LECTRIC Model "G" Terminator on page 77)



The combination of the Stripping Module with the AMP 3K/40 and AMP 5K/40 Terminating Machines or the AMP-O-LECTRIC Model "G" Terminator provides an economic and proficient method of stripping the wire and crimping terminals on the same machine. The module accepts End- and Side-Feed HDM Applicators (32-14 AWG) and operates in three modes: crimp only, strip only, or strip and crimp. It can be installed on existing machines in the field or purchased as one unit from the factory.

For more information, request Catalog **1309085**.

Tooling Numerical Index

Application Tooling/Technical Document Cross Reference

| Part No. | Instruction Sheet |
|----------|-------------------|
| 58541-1 | 408-4051 |
| 58495-1 | 408-9819 |
| 69710-1 | 408-2095 |
| 91550-1 | 408-7608 |
| 91521-1 | 408-7608 |
| 91519-1 | 408-7942 |
| 91019-3 | 408-7276 |
| 91067-2 | 408-7508 |
| 189721-2 | 408-5862 |
| 189722-2 | 408-5862 |
| 305183 | 408-1216 |

Tooling Numerical Index

| Part No. | Page No. | Part No. | Page No. |
|----------|-----------------------------|----------|--------------------------------------|
| 45098 | 30 | 200893 | 30,31,32 |
| 45638 | 42 | 217201 | 31,33 |
| 45639 | 42 | 224155 | 38 |
| 45740 | 42 | 305183 | 30,31,32,35,36, 37,39,41,42,59,60 |
| 58290 | 43 | 318161 | 30,36,37,39,41,42 |
| 58305 | 30 | 354940 | 39,40,42 |
| 58448 | 14 | 356114 | 38 |
| 58495 | 31,34 | 356119 | 38 |
| 58541 | 30 | 356304 | 30,31,34,36, 37,39,41,43 |
| 69186 | 42 | 356336 | 22 |
| 69220 | 42 | 466321 | 31 |
| 69222 | 42 | 466323 | 31,34 |
| 69227 | 42 | 466324 | 31 |
| 69248 | 42 | 466325 | 31 |
| 69315 | 42 | 466326 | 31 |
| 69360 | 42 | 466383 | 31 |
| 69373 | 42 | 466422 | 14 |
| 69656 | 39,40 | 466423 | 14 |
| 69672 | 42 | 466585 | 31 |
| 69690 | 39 | 466598 | 31 |
| 69710 | 37,39,41,42 | 466741 | 34 |
| 69875 | 30 | 466758 | 14 |
| 90066 | 31,34 | 466900 | 14 |
| 90067 | 31,34 | 466901 | 14 |
| 90121 | 36 | 466906 | 31 |
| 90122 | 36 | 466907 | 31,34 |
| 90136 | 30 | 466908 | 31 |
| 90140 | 38 | 466923 | 31 |
| 90145 | 37 | 466942 | 31 |
| 90225 | 31 | 466958 | 31 |
| 90230 | 30 | 466963 | 14 |
| 90231 | 30 | 466968 | 14 |
| 90249 | 30 | 466979 | 31 |
| 90250 | 30 | 567021 | 37 |
| 90265 | 15 | 567036 | 14 |
| 90302 | 14 | 567363 | 31 |
| 90310 | 31 | 567364 | 31 |
| 90331 | 31 | 567455 | 37 |
| 90374 | 14 | 567801 | 14 |
| 90405 | 15 | 567804 | 14 |
| 90406 | 14 | 567849 | 14 |
| 90716 | 31 | 567867 | 31 |
| 91002 | 31 | 567947 | 31 |
| 91016 | 78 | 601967 | 30,37 |
| 91019 | 37 | 608651 | 21 |
| 91067 | 19 | 608668 | 21 |
| 91285 | 14 | 680114 | 34 |
| 91911 | 39,40 | 680602 | 31 |
| 91912 | 42 | 725840 | 34 |
| 126195 | 19 | 811262 | 78,81 |
| 189721 | 30,31,33,36, 37,39,40,43 | 1016002 | 14 |
| 189722 | 30,31,33,36, 37,39,40,43 | 1616015 | 14 |
| 189928 | 30,31,33,36, 37,39,40,43 | | |

Technical Documents

The following is a list of technical documents that provide specifications, application and performance data for M Series connectors, contacts, tooling and hardware.

Product Specifications describe technical performance characteristics and verification tests. They are intended for the Design, Component and Quality Engineer.

- 108-10001 M Series Connectors
- 108-10024 CPC Connectors
- 108-10037 Contacts, Type XII
- 108-10039 Type II Contacts
- 108-10040 Metal-Shell CPC Connectors
- 108-10042 Type III+ Contacts
- 108-10108 Type I Contacts
- 108-12011 Subminiature COAXICON Contacts
- 108-12021 Miniature COAXICON Contacts

Application Specifications describe requirements for using the product in its intended application and/or crimping information. They are intended for the Packaging and Design Engineer and the Machine Setup Person.

- 114-10000 Contacts, Size 20 DF
- 114-10004 Type III+ Contacts, Application of
- 114-10005 Type XII Contacts, Application of
- 114-10026 Type II Contacts
- 114-10038 CPC Connectors

Instruction Sheets provide instructions for assembling or applying the product. They are intended for the Manufacturing Assembler or Operator.

- 408-1379 Selection Charts for Multimate Pin and Socket Contacts
- 408-7053 Selection Chart for Type I Pin and Socket Contacts
- 408-1770 Selection Chart for Miniature COAXICON Contacts
- 408-7170 6, 14, 20 and 41 Position M Series Connectors
- 408-7177 21 and 26 Position M Series Connectors
- 408-7161 34 and 50 Position and 20 Position (High Voltage) M Series Connectors
- 408-7164 75 and 104 Position M Series Connectors
- 408-7005 104 CF Position M Series Connectors
- 408-7293 160 CF Position M Series Connectors
- 408-7105 14, 20, 26 and 41 Position M Series Connector Kits
- 408-7107 34 and 50 Position M Series Connector Kits
- 408-7730 34, 50, 75 and 104 Position M Series Connector Kits
- 408-7108 75 and 104 Position M Series Connector Kits
- 408-7048 15 Position (Mixed) M Series Connectors
- 408-7455 29 Position (Mixed) M Series Connectors
- 408-6800 Shield Kit 208783-1 for 104 Position M Series Connector
- 408-7485 Press-Fit Jackscrews for M Series Connectors
- 408-7066 Locking Springs for 14, 20, 21, 26 and 41 Position M Series Connectors
- 408-7067 Locking Springs for 34 and 50 Position M Series Connectors
- 408-7055 Corner Guide Pins and Sockets for 34 and 50 Position M Series Connectors
- 408-7056 Corner Guide Pins and Sockets for 75 and 104 Position M Series Connectors
- 408-7121 Guide Pins and Sockets for 104 CF Position M Series Connectors
- 408-7013 Pin Hoods for M Series Connectors

Technical Documents (Continued)

Instruction Sheets provide instructions for assembling or applying the product. They are intended for the Manufacturing Assembler or Operator. (Continued)

- 408-7094 Pin Hoods w/Mounting Flange for 34 and 50 Position M Series Connectors
- 408-7103 Pin Hoods w/Mounting Flange for 41 Position M Series Connectors
- 408-7095 Pin Hoods w/Mounting Flange for 75 Position M Series Connectors
- 408-9731 M Series V.35 Cable Connector Kits
- 408-7089 Pin Hoods, Closed-End, for 104 CF Position M Series Connectors
- 408-1238 Shields (Long) for 34 and 50 Position M Series Connectors
- 408-1197 Shields (Short) for 34 and 50 Position M Series Connectors
- 408-1298 Shields, 180° (Long) for 14, 20, 26, 34 and 50 Position M Series Connectors
- 408-1312 Shields, 180° (Short) for 14, 20, 26, 34 and 50 Position M Series Connectors
- 408-1296 Shields, 90° (Long) for 14, 20, 26, 34 and 50 Position M Series Connectors
- 408-1297 Shields, 90° (Short) for 14, 20, 26, 34 and 50 Position M Series Connectors
- 408-7026 Shields, 90° (Short) for 21 and 41 Position M Series Connectors
- 408-1192 Shields, 180° (Long and Short) for 26 and 41 Position M Series Connectors
- 408-7220 Shields, 180° and 90° (Long and Short) for 75 Position M Series Connectors
- 408-1321 Shields, 90° (Short) for 104 Position M Series Connectors
- 408-7148 Shields, 90° and 45° (Long) for 104 CF Position M Series Connectors
- 408-7088 Shields, 45° (Short) for 104 CF Position M Series Connectors
- 408-7423 Shields, 45° (Short) for 160 CF Position M Series Connectors
- 408-7017 Strain Relief Clamps (Long) for 14 and 20 Position M Series Connectors
- 408-7018 Strain Relief Clamps (Long) for 26 Position M Series Connectors
- 408-1313 Strain Relief Clamps (Short) for 14, 20 and 26 Position M Series Connectors
- 408-7012 Strain Relief Clamps (Long and Short) for 21 and 41 Position M Series Connectors
- 408-7019 Strain Relief Clamps (Long) for 34 Position M Series Connectors
- 408-1317 Strain Relief Clamps (Short) for 34 and 50 Position M Series Connectors
- 408-7216 Strain Relief Clamps (Long) for 75 Position M Series Connectors
- 408-1368 Strain Relief Clamps (Short) for 75 Position M Series Connectors
- 408-7020 Strain Relief Clamps (Long) for 50 and 104 Position M Series Connectors
- 408-1322 Strain Relief Clamps (Short) for 104 Position M Series Connectors
- 408-1340 Keying Plug (Cylindrical) for Multimate Contact Cavities
- 408-6613 Application and Maintenance of AMP Hand Crimping Tool 90067
- 408-7414 Application and Maintenance of AMP Hand Crimping Tool 90225-2
- 408-7942 Application and Maintenance of AMP Hand Crimping Tool 90310-2
- 408-7773 Application and Maintenance of AMP Hand Crimping Tool 90331-1
- 408-7126 AMP Assembly Tool 91016 for Turnable Jackscrews

Part Number Index

Note: This numerical index lists all cataloged parts by base no. only. Complete part nos. (with prefixes and/or suffixes) are shown on the page(s) indicated.

| Part No. | Page | Part No. | Page | Part No. | Page |
|----------|--------|----------|--------|----------|------|
| 50079 | 42 | 164159 | 34 | 201349 | 83 |
| 50080 | 42 | 164160 | 34 | 201350 | 83 |
| 51565 | 39, 40 | 164161 | 34 | 201355 | 45 |
| 66098 | 31 | 164162 | 34 | 201356 | 45 |
| 66099 | 31 | 164163 | 34 | 201357 | 47 |
| 66100 | 31 | 164164 | 34 | 201358 | 47 |
| 66101 | 31 | 193990 | 38 | 201359 | 47 |
| 66102 | 31 | 193991 | 38 | 201360 | 86 |
| 66103 | 31 | 200277 | 47 | 201363 | 82 |
| 66104 | 31 | 200333 | 30 | 201364 | 82 |
| 66105 | 31 | 200336 | 30 | 201368 | 83 |
| 66106 | 31 | 200346 | 45 | 201369 | 82 |
| 66107 | 31 | 200389 | 81 | 201378 | 86 |
| 66108 | 31 | 200390 | 81 | 201384 | 86 |
| 66109 | 31 | 200512 | 47 | 201388 | 78 |
| 66180 | 35 | 200514 | 85 | 201389 | 78 |
| 66181 | 35 | 200517 | 85 | 201390 | 83 |
| 66182 | 35 | 200532 | 85 | 201413 | 78 |
| 66183 | 35 | 200686 | 88 | 201414 | 78 |
| 66253 | 37 | 200730 | 88 | 201443 | 85 |
| 66254 | 37 | 200821 | 89 | 201469 | 86 |
| 66255 | 37 | 200833 | 81 | 201501 | 78 |
| 66256 | 37 | 200835 | 81 | 201511 | 43 |
| 66259 | 37 | 200838 | 47 | 201512 | 43 |
| 66260 | 37 | 200867 | 78 | 201532 | 50 |
| 66261 | 37 | 200868 | 78 | 201540 | 81 |
| 66262 | 37 | 200870 | 78 | 201568 | 30 |
| 66331 | 31 | 200871 | 78 | 201570 | 30 |
| 66332 | 31 | 200874 | 79 | 201571 | 85 |
| 66358 | 31 | 200875 | 79 | 201576 | 85 |
| 66359 | 31 | 201037 | 49 | 201578 | 30 |
| 66360 | 31 | 201046 | 81 | 201580 | 30 |
| 66361 | 31 | 201047 | 81 | 201611 | 30 |
| 66393 | 31 | 201087 | 78 | 201613 | 30 |
| 66394 | 31 | 201088 | 78 | 201692 | 50 |
| 66399 | 31 | 201089 | 79 | 201766 | 88 |
| 66400 | 31 | 201092 | 79 | 201785 | 82 |
| 66405 | 31 | 201131 | 85 | 201786 | 82 |
| 66406 | 31 | 201142 | 42, 43 | 201827 | 78 |
| 66424 | 31 | 201143 | 43 | 201828 | 78 |
| 66425 | 31 | 201144 | 43 | 201843 | 88 |
| 66428 | 31 | 201145 | 43 | 201845 | 88 |
| 66429 | 31 | 201146 | 43 | 201846 | 88 |
| 66459 | 32 | 201165 | 86 | 201847 | 88 |
| 66460 | 32 | 201169 | 86 | 201848 | 88 |
| 66461 | 32 | 201182 | 88 | 201849 | 88 |
| 66468 | 32 | 201224 | 88 | 201910 | 78 |
| 66470 | 32 | 201227 | 86 | 201911 | 78 |
| 66471 | 32 | 201229 | 88 | 201918 | 80 |
| 66473 | 32 | 201237 | 88 | 201921 | 80 |
| 66563 | 31 | 201298 | 45 | 201922 | 80 |
| 66564 | 31 | 201302 | 47 | 201923 | 80 |
| 66565 | 31 | 201310 | 49 | 201925 | 80 |
| 66566 | 31 | 201311 | 49 | 201926 | 80 |
| 66597 | 31 | 201328 | 30 | 202095 | 83 |
| 66598 | 31 | 201330 | 30 | 202096 | 83 |
| 66601 | 31 | 201332 | 30 | 202110 | 87 |
| 66602 | 31 | 201334 | 30 | 202119 | 83 |
| 66740 | 37 | 201345 | 49 | 202135 | 47 |
| 66741 | 37 | 201346 | 83 | 202165 | 83 |

Part Number Index (Continued)

Note: This numerical index lists all cataloged parts by base no. only. Complete part nos. (with prefixes and/or suffixes) are shown on the page(s) indicated.

| Part No. | Page | Part No. | Page |
|----------|-------|----------|--------|
| 202169 | 87 | 205514 | 56 |
| 202173 | 81 | 205515 | 57 |
| 202174 | 81 | 205516 | 72 |
| 202236 | 35 | 205606 | 60 |
| 202237 | 35 | 205628 | 60 |
| 202383 | 85 | 205629 | 60 |
| 202394 | 82 | 205630 | 60 |
| 202395 | 85 | 205689 | 76 |
| 202417 | 36 | 205690 | 76 |
| 202418 | 36 | 205720 | 59 |
| 202421 | 36 | 206508 | 89 |
| 202422 | 36 | 207234 | 78 |
| 202434 | 82 | 207235 | 78 |
| 202478 | 73 | 207597 | 89 |
| 202479 | 73 | 207619 | 81 |
| 202483 | 87 | 212618 | 30 |
| 202507 | 30 | 212810 | 64 |
| 202508 | 30 | 213289 | 65 |
| 202515 | 74 | 213300 | 68 |
| 202516 | 74 | 213473 | 66 |
| 202711 | 85 | 213513 | 65 |
| 202713 | 85 | 213521 | 59 |
| 202725 | 30 | 213522 | 68 |
| 202726 | 30 | 213524 | 66 |
| 202757 | 45 | 213550 | 67 |
| 202758 | 45 | 213574 | 64 |
| 202798 | 87 | 213684 | 70 |
| 202799 | 51,59 | 213685 | 70 |
| 202800 | 51 | 213753 | 68 |
| 203432 | 88 | 213763 | 59 |
| 203535 | 77 | 213799 | 47 |
| 203540 | 77 | 213800 | 47 |
| 203618 | 77 | 213801 | 47 |
| 203622 | 48,60 | 213802 | 47 |
| 203743 | 82 | 213803 | 71 |
| 203744 | 83 | 213804 | 71 |
| 203908 | 75 | 213805 | 71 |
| 203909 | 75 | 213806 | 64 |
| 203956 | 47,60 | 213807 | 64 |
| 203964 | 81 | 213808 | 65 |
| 203966 | 81 | 213809 | 66 |
| 203975 | 85 | 213931 | 69 |
| 204087 | 85 | 213932 | 69 |
| 204099 | 81 | 221848 | 42 |
| 204219 | 30 | 225088 | 39 |
| 204258 | 82 | 226537 | 39, 40 |
| 204814 | 77 | 328663 | 42 |
| 205042 | 72 | 328664 | 42 |
| 205043 | 72 | 328666 | 42 |
| 205058 | 48 | 328667 | 42 |
| 205156 | 56 | 329029 | 42 |
| 205317 | 54 | 330478 | 42 |
| 205359 | 57 | 330587 | 42 |
| 205361 | 56 | 332056 | 39 |
| 205505 | 56 | 332057 | 39, 40 |
| 2075507 | 54 | 788085 | 31 |
| 205508 | 54 | 788088 | 31 |
| 205509 | 54 | | |
| 205511 | 54 | | |
| 205512 | 54 | | |



Компания «ЭлектроПласт» предлагает заключение долгосрочных отношений при поставках импортных электронных компонентов на взаимовыгодных условиях!

Наши преимущества:

- Оперативные поставки широкого спектра электронных компонентов отечественного и импортного производства напрямую от производителей и с крупнейших мировых складов;
- Поставка более 17-ти миллионов наименований электронных компонентов;
- Поставка сложных, дефицитных, либо снятых с производства позиций;
- Оперативные сроки поставки под заказ (от 5 рабочих дней);
- Экспресс доставка в любую точку России;
- Техническая поддержка проекта, помощь в подборе аналогов, поставка прототипов;
- Система менеджмента качества сертифицирована по Международному стандарту ISO 9001;
- Лицензия ФСБ на осуществление работ с использованием сведений, составляющих государственную тайну;
- Поставка специализированных компонентов (Xilinx, Altera, Analog Devices, Intersil, Interpoint, Microsemi, Aeroflex, Peregrine, Syfer, Eurofarad, Texas Instrument, Miteq, Cobham, E2V, MA-COM, Hittite, Mini-Circuits, General Dynamics и др.);

Помимо этого, одним из направлений компании «ЭлектроПласт» является направление «Источники питания». Мы предлагаем Вам помощь Конструкторского отдела:

- Подбор оптимального решения, техническое обоснование при выборе компонента;
- Подбор аналогов;
- Консультации по применению компонента;
- Поставка образцов и прототипов;
- Техническая поддержка проекта;
- Защита от снятия компонента с производства.



Как с нами связаться

Телефон: 8 (812) 309 58 32 (многоканальный)

Факс: 8 (812) 320-02-42

Электронная почта: org@eplast1.ru

Адрес: 198099, г. Санкт-Петербург, ул. Калинина, дом 2, корпус 4, литера А.