



## 60W Passive Power over Ethernet Adapter Lowest Cost Ultra PoE Power Injector



### Features

- Continuous flow of power with no detection
- Very Low leakage
- Non-Vented Case
- 2 or 3 Wire Options
- 1 Year Warranty
- Lowest Cost Ultra PoE
- Full Protection OCP, OVP
- Level VI Efficiency
- Optional Gigabit Base-T Data Rate

### Applications

- Satellite Receivers
- Wireless Network Access Points
- Kiosks
- Security Camera
- LCD Displays
- WiMax Access Points

### Safety Approvals

- cUL/UL
- CE

### Mechanical Characteristics

- Length: 163mm (6.4in)
- Width: 65mm (2.56in)
- Height: 36mm (1.42in)
- Weight: 0.4Kg

### Output Specifications

Model Number	Output Voltage	Output Current	Input Connector	Gigabit
POE61W -560D-R <sup>1</sup>	56V	1.1A	2 Wire C8	No
POE61W- 560DG-R <sup>1</sup>	56V	1.1A	2 Wire C8	Yes

Notes: (1) Consult factory for availability

Phihong is not responsible for any error, and reserves the right to make changes without notice. Please visit our website at [www.phihong.com](http://www.phihong.com) for the most up-to-date specifications and contact information.

**INPUT:****AC Input Voltage Range**

90 to 264VAC

**AC Input Voltage Rating**

100 to 240VAC, 47-63Hz

**AC Input Current**

2.0A (RMS) maximum for 90VAC

1.2A (RMS) maximum for 240VAC

**Leakage Current**

0.25mA maximum fro 264VAC, 50Hz

**AC Inrush Current**

30A maximum for 115VAC

60A maximum for 230VAC

(at cold start, 25°C)

**OUTPUT:****Total Output Power**

60W

**Output Ripple**

250mVp-p

**DC Offset**

No data degradation with DC imbalance 18mA

**Efficiency**

DOE Level VI

**Hold-up Time**

10mS min. 120VAC and maximum load

**ENVIRONMENTAL:****Temperature**

Operation 0 to +40°C

Non-operation -20 to +65°C

Humidity 5 to 90%

**EMC**

Complies with FCC Class B

Complies with EN55032 Class B

**Isolation Test**Primary to Secondary: 4242VDC for 1 minute,  
10mAPrimary to F.G.: 2121VDC for 1 minute,  
10mASecondary to F.G.: 2121VDC for 1 minute,  
10mA**Immunity**

ESD: EN61000-4-2. Level 3

RS: EN61000-4-3. Level 2

EFT: EN61000-4-4. Level 2

Surge: EN61000-4-5. Level 3

CS: EN61000-4-6. Level 2

Voltage Dips EN61000-4-11

Harmonic: EN61000-3-2 Class A

**Insulation Resistance**

Primary to Secondary: &gt;10M OHM 500VDC

Primary to Field Ground: >10M OHM  
500VDC**FEATURE:****Over Voltage/Current, Short Circuit Protection**Outputs equipped with short circuit protection  
and overload protection.The output can be shorted permanently without  
damage**Input Connector**

IEC320 C8

**Output Connection**

4-pair powering for Gigabit models

Pins 3,6, 4,5(+) Pins 1,2, 7,8 (-)

2-pair powering for non-gigabit models

Pins 4,5(+) Pins 7,8 (-)

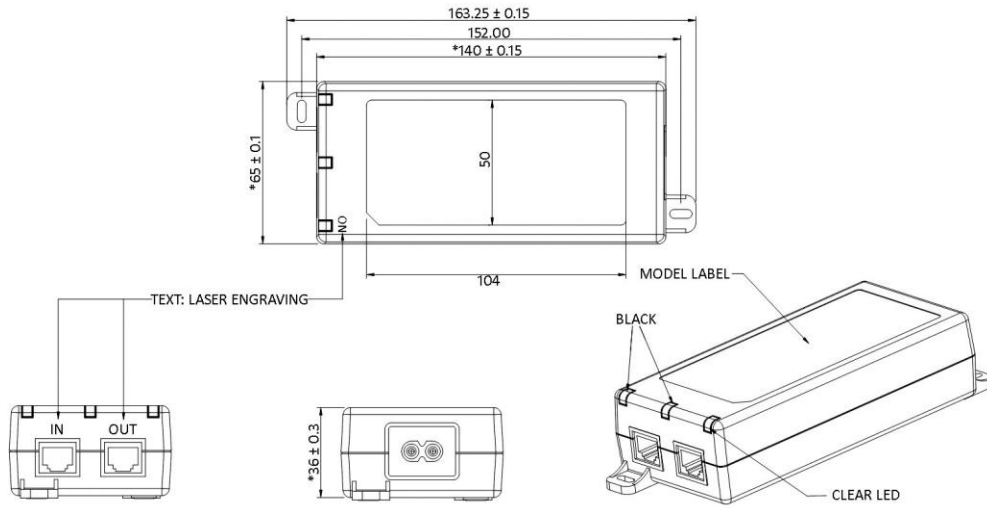

**Supplier's Declaration of Conformity**  
**47 CFR § 2.1077 Compliance Information**

Phihong USA Corporation  
47800 Fremont Boulevard  
Fremont, CA 94538  
Telephone: (510) 445-0100  
[www.phihong.com](http://www.phihong.com)

NOTE: This model has/The models in this products series have been tested and found to comply with the limits for a Class B digital device, pursuant to part 15 of the FCC Rules. These limits are designed to provide reasonable protection against harmful interference in a residential installation. This equipment generates, uses and can radiate radio frequency energy and, if not installed and used in accordance with the instructions, may cause harmful interference to radio communications. However, there is no guarantee that interference will not occur in a particular installation. If this equipment does cause harmful interference to radio or television reception, which can be determined by turning the equipment off and on, the user is encouraged to try to correct the interference by one or more of the following measures:

- Reorient or relocate the receiving antenna.
- Increase the separation between the equipment and receiver.
- Connect the equipment into an outlet on a circuit different from that to which the receiver is connected.
- Consult the dealer or an experienced radio/TV technician for help.

Changes or modifications to equipment not expressly approved by PHIHONG could void the user's authority to operate the equipment.



Компания «ЭлектроПласт» предлагает заключение долгосрочных отношений при поставках импортных электронных компонентов на взаимовыгодных условиях!

Наши преимущества:

- Оперативные поставки широкого спектра электронных компонентов отечественного и импортного производства напрямую от производителей и с крупнейших мировых складов;
- Поставка более 17-ти миллионов наименований электронных компонентов;
- Поставка сложных, дефицитных, либо снятых с производства позиций;
- Оперативные сроки поставки под заказ (от 5 рабочих дней);
- Экспресс доставка в любую точку России;
- Техническая поддержка проекта, помощь в подборе аналогов, поставка прототипов;
- Система менеджмента качества сертифицирована по Международному стандарту ISO 9001;
- Лицензия ФСБ на осуществление работ с использованием сведений, составляющих государственную тайну;
- Поставка специализированных компонентов (Xilinx, Altera, Analog Devices, Intersil, Interpoint, Microsemi, Aeroflex, Peregrine, Syfer, Eurofarad, Texas Instrument, Miteq, Cobham, E2V, MA-COM, Hittite, Mini-Circuits, General Dynamics и др.);

Помимо этого, одним из направлений компании «ЭлектроПласт» является направление «Источники питания». Мы предлагаем Вам помощь Конструкторского отдела:

- Подбор оптимального решения, техническое обоснование при выборе компонента;
- Подбор аналогов;
- Консультации по применению компонента;
- Поставка образцов и прототипов;
- Техническая поддержка проекта;
- Защита от снятия компонента с производства.



#### Как с нами связаться

**Телефон:** 8 (812) 309 58 32 (многоканальный)

**Факс:** 8 (812) 320-02-42

**Электронная почта:** [org@eplast1.ru](mailto:org@eplast1.ru)

**Адрес:** 198099, г. Санкт-Петербург, ул. Калинина, дом 2, корпус 4, литера А.