



SANYO Semiconductors

# DATA SHEET

## LA6586FA — Monolithic Linear IC An ON Semiconductor Company BTL Driver Single-Phase Full-Wave Fan Motor Driver

### Overview

The LA6586FA is Single-phase bipolar fan motor is put into silent driving by means of BTL output linear drive, offering high efficiency and power saving by suppressing the reactive current. Lock protection and rotation signal (FG, RD) circuits are built in, ensuring optimum application to small fans for notebook PC, consumer equipment power supply, car audio system, CPU cooler, etc. that require high reliability and low noise.

### Functions

- Single-phase full-wave linear drive by BTL output (gain resistance 1k $\Omega$ -360k $\Omega$ , 51dB)
- Low-voltage operation possible, with wide operating voltage range (2.2 to 14.0V)
- Low saturation output (Upper + lower saturation voltage : Vosat (total)=1.2Vtyp, IO=200mA)
- Built-in lock protection and automatic reset circuits
- Built-in FG&RD outputs
- Thermal protection circuit
- Built-in Hall bias (VHB=1.3V)
- Extra-small package (Micro10)

### Specifications

**Absolute Maximum Ratings** at Ta = 25 °C

Parameter	Symbol	Conditions	Ratings	Unit
Output voltage	V <sub>CC</sub> max		15	V
Allowable power dissipation	Pd max	Mounted on a specified board*	400	mW
Output current	I <sub>OUT</sub> max		0.6	A
Output withstand voltage	V <sub>OUT</sub> max		15	V
RD/FG output pin output withstand voltage	VRD/FG max		15	V
RD/FG output current	IRD/FG max		10	mA
HB output current	IB max		10	mA
Operating temperature	Topr		-30 to +90	°C
Storage temperature	Tstg		-55 to +150	°C

Continued on next page.

- Any and all SANYO Semiconductor Co.,Ltd. products described or contained herein are, with regard to "standard application", intended for the use as general electronics equipment. The products mentioned herein shall not be intended for use for any "special application" (medical equipment whose purpose is to sustain life, aerospace instrument, nuclear control device, burning appliances, transportation machine, traffic signal system, safety equipment etc.) that shall require extremely high level of reliability and can directly threaten human lives in case of failure or malfunction of the product or may cause harm to human bodies, nor shall they grant any guarantee thereof. If you should intend to use our products for new introduction or other application different from current conditions on the usage of automotive device, communication device, office equipment, industrial equipment etc. , please consult with us about usage condition (temperature, operation time etc.) prior to the intended use. If there is no consultation or inquiry before the intended use, our customer shall be solely responsible for the use.
- Specifications of any and all SANYO Semiconductor Co.,Ltd. products described or contained herein stipulate the performance, characteristics, and functions of the described products in the independent state, and are not guarantees of the performance, characteristics, and functions of the described products as mounted in the customer's products or equipment. To verify symptoms and states that cannot be evaluated in an independent device, the customer should always evaluate and test devices mounted in the customer's products or equipment.

# LA6586FA

Continued from preceding page.

\*Mounted on a specified board : 20mm×10mm×0.8mm, paper phenol

Caution 1) Absolute maximum ratings represent the value which cannot be exceeded for any length of time.

Caution 2) Even when the device is used within the range of absolute maximum ratings, as a result of continuous usage under high temperature, high current, high voltage, or drastic temperature change, the reliability of the IC may be degraded. Please contact us for the further details.

## Recommended Operating Range at Ta = 25 °C

Parameter	Symbol	Conditions	Ratings	Unit
Supply voltage	V <sub>CC</sub>		2.2 to 14.0	V
Common-phase input voltage range of Hall input	V <sub>ICM</sub>		0 to V <sub>CC</sub> -1.5	V

## Electrical Characteristics at Ta = 25 °C, V<sub>CC</sub> = 12 V

Parameter	Symbol	Conditions	Ratings			Unit
			min	typ	max	
Circuit current	I <sub>CC1</sub>	During drive (CT = L)	3	6	9	mA
	I <sub>CC2</sub>	During lock protection (CT = H)	2.5	5	7.5	mA
Lock detection capacitor charge current	I <sub>CT1</sub>		0.9	1.2	1.5	μA
Capacitor discharge current	I <sub>CT2</sub>		0.10	0.18	0.25	μA
Capacitor charge and discharge current ratio	RCT	RCT = I <sub>CT1</sub> /I <sub>CT2</sub>	5	6.5	8	-
CT charge voltage	V <sub>CT1</sub>		1.3	1.5	1.7	V
CT discharge voltage	V <sub>CT2</sub>		0.3	0.5	0.7	V
OUT output L saturation voltage	V <sub>OL</sub>	I <sub>O</sub> = 200 mA		0.25	0.45	V
OUT output H saturation voltage	V <sub>OH</sub>	I <sub>O</sub> = 200 mA		0.95	1.2	V
Input offset voltage	V <sub>OFST</sub>			3	6	mV
Hall input sensitivity	V <sub>HN</sub>	Zero peak value (including offset and hysteresis)		7	15	mV
Hall bias output L voltage	V <sub>HB</sub>	I <sub>HB</sub> = 5 mA	1.3	1.5	1.7	V
RD/FG input pin L voltage	V <sub>FG</sub>	I <sub>RD/FG</sub> = 5 mA		0.15	0.3	V
RD/FG input pin leak current	I <sub>IFGL</sub>	V <sub>RD/FG</sub> = 15 V		1	30	μA
Overheat protection circuit	TSD	(*1) Designed target value	150	180	210	°C

(\*1) The standard is a design target and the measurement with a single unit is not made.

## Package Dimensions

unit : mm

3428

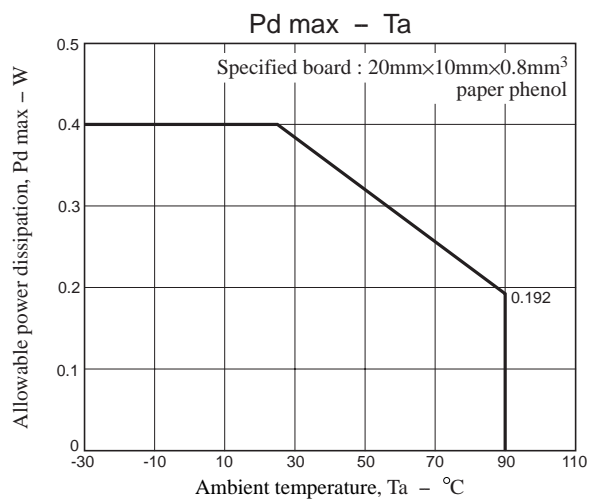
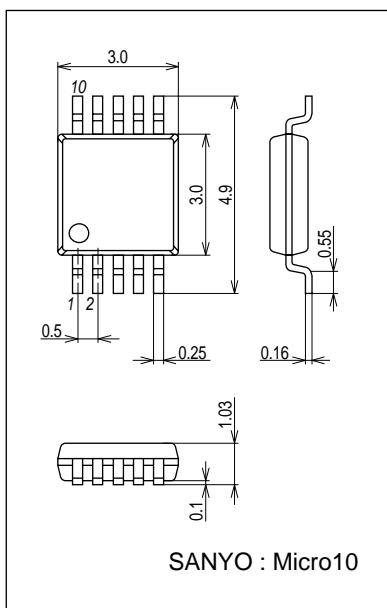

# LA6586FA

## Truth Table

IN-	IN+	CT	OUT1	OUT2	FG	RD	Mode
H	L	L	H	L	L	L	During rotation
L	H		L	H	H		
-	-	H	OFF	OFF	-	H	During overheat protection

## Pin Assignment

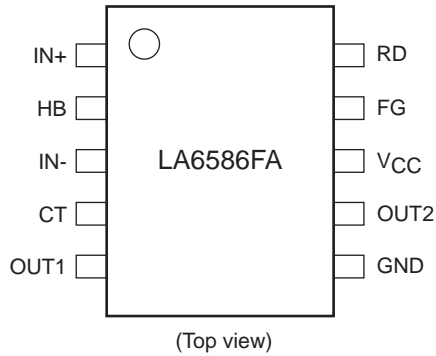

## Sample Application Circuit

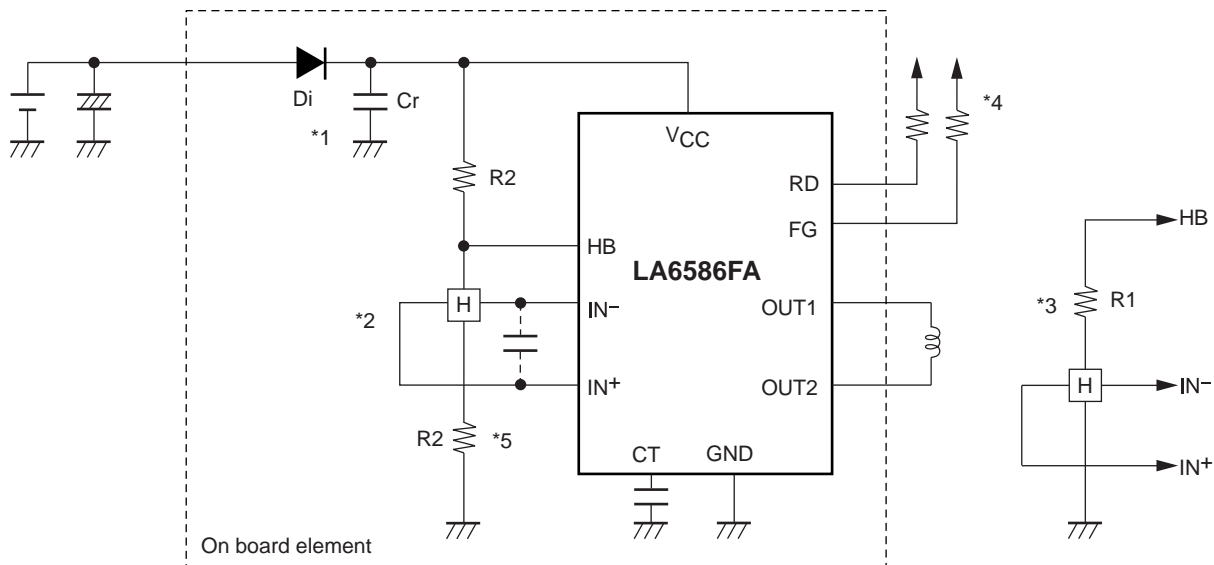

- \*1 To enhance the reliability, it is necessary to insert a capacitor Cr to secure the regenerative current route.
- \*2 To obtain Hall bias from VCC, carry out  $1/2 \times V_{CC}$  bias as shown in the figure. Linear driving is made through voltage control of the coil by amplifying the Hall output. When the Hall element output is large, the startup performance and efficiency are improved. Adjustment of the Hall element can reduce the noise further.
- \*3 To obtain Hall bias from the HB pin, carry out constant-voltage bias at about 1.5 V, which enables the Hall element to generate the stable Hall output satisfactory in temperature characteristics. The Hall output amplitude is adjusted with R1. (In the case of  $V_{CC} = 12$  V, \*2 proves advantageous in terms of heat generation in IC.)
- \*4 Keep this open when not used.
- \*5 When the wiring from the Hall output to IC Hall input is long, noise may be carried through the wiring. In this case, insert the capacitor as shown in the figure.

# LA6586FA

## Internal Equivalent Circuit

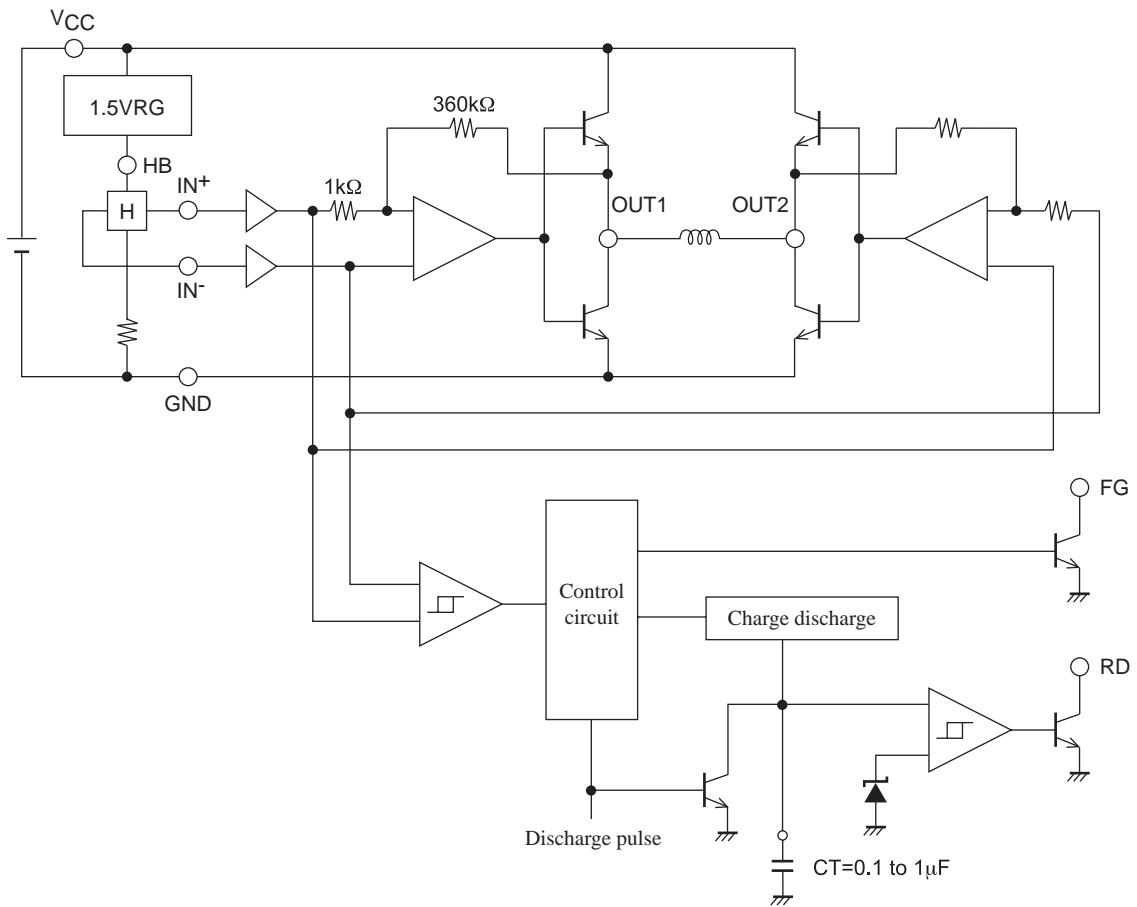

## Test Circuit Diagram

Input current ( $I_{CC}$ )

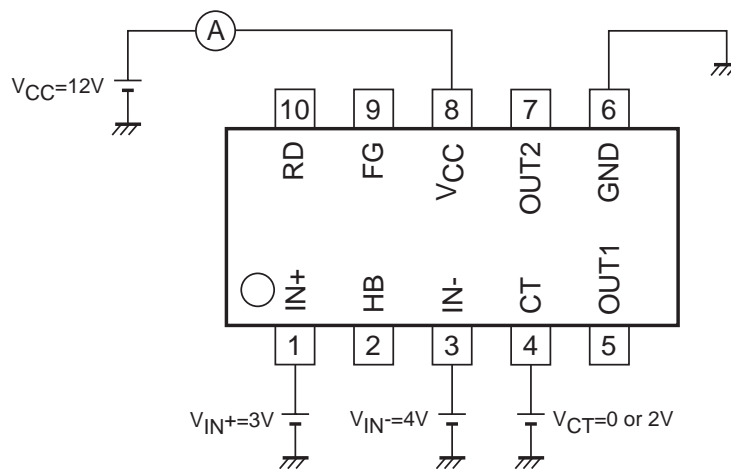

# LA6586FA

## CT pin charge/discharge current ( $I_{CT}$ )

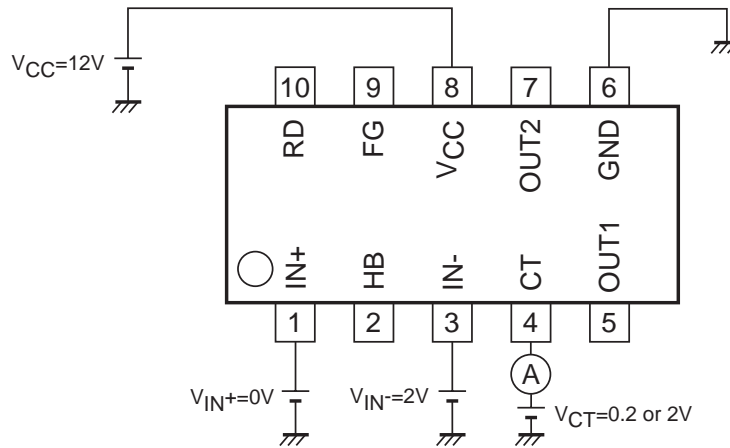

## CT pin charge/discharge voltage ( $V_{CT}$ )

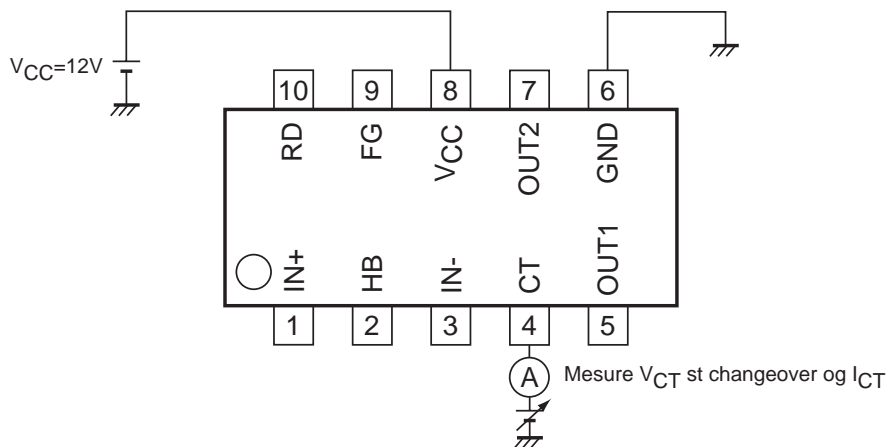

## OUT output saturation voltage ( $V_{OL}$ , $V_{OH}$ )

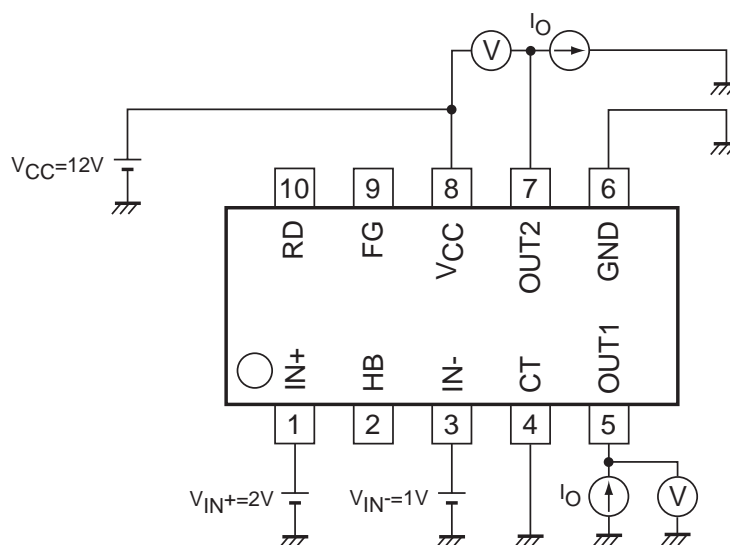

# LA6586FA

## Input offset voltage (VOFST)

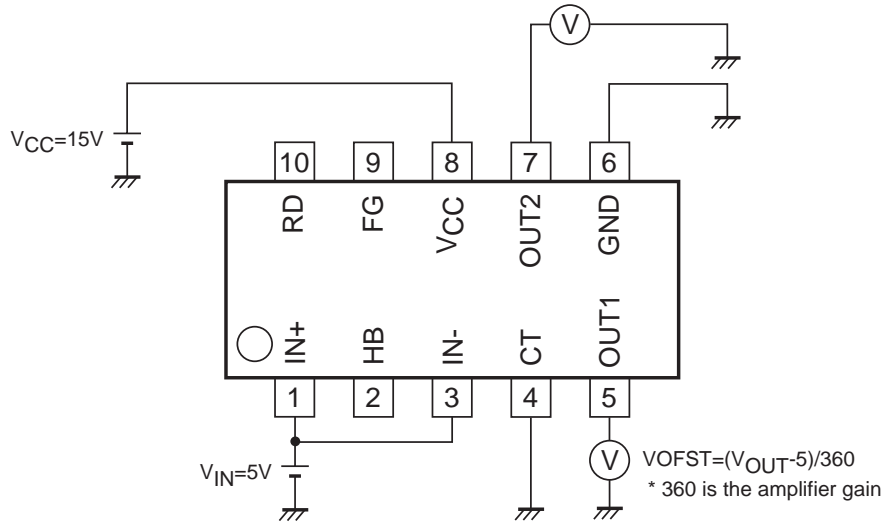

## Hall input sensitivity (VHN)

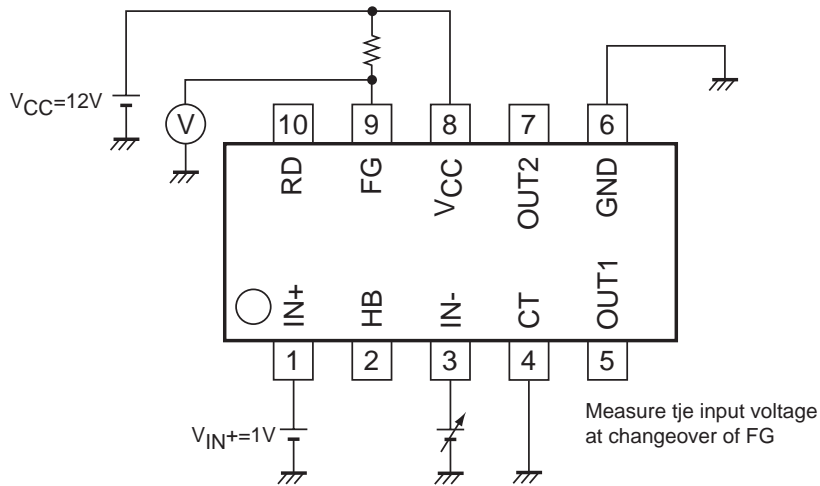

## Hall bias output voltage (VHB)

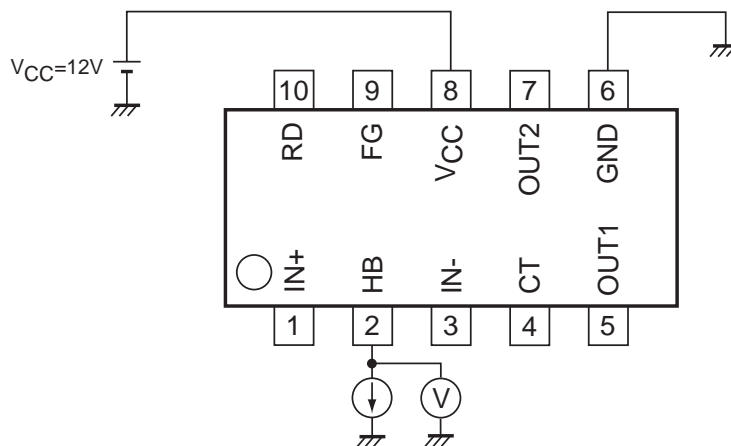

# LA6586FA

FG, RD input pin L voltage (VFG, RD)

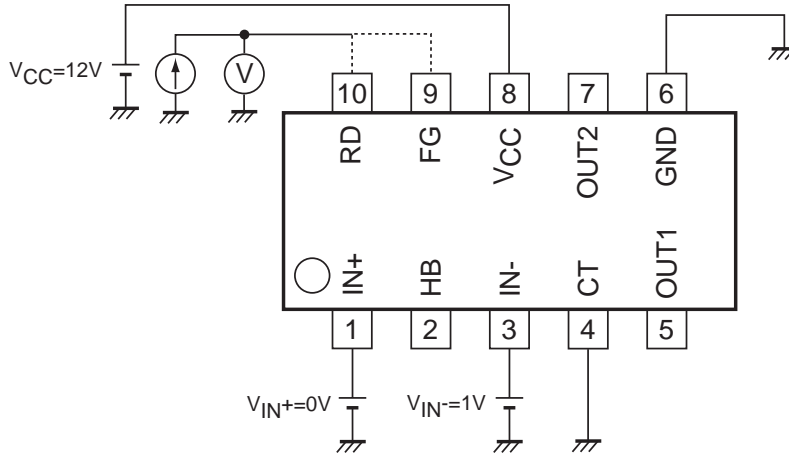

FG, RD input pin leakage current (IFGL, RDL)

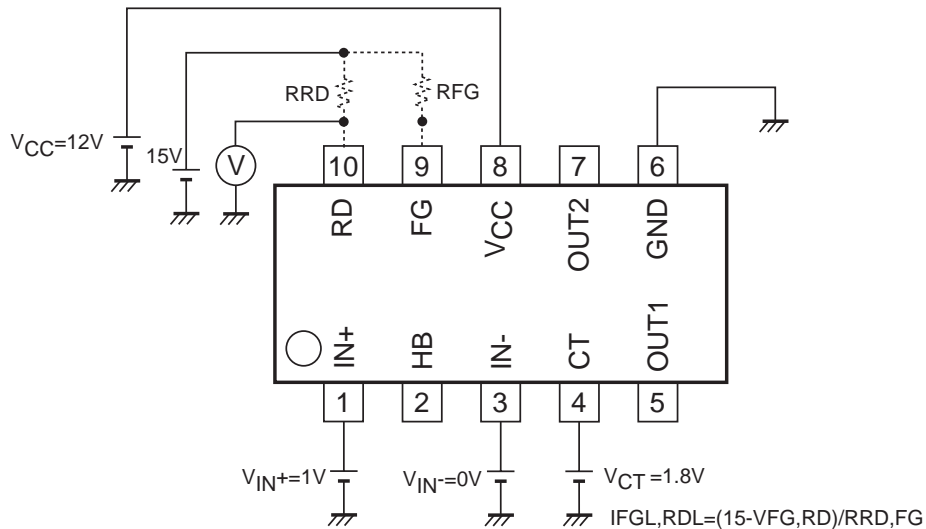

- SANYO Semiconductor Co.,Ltd. assumes no responsibility for equipment failures that result from using products at values that exceed, even momentarily, rated values (such as maximum ratings, operating condition ranges, or other parameters) listed in products specifications of any and all SANYO Semiconductor Co.,Ltd. products described or contained herein.
- SANYO Semiconductor Co.,Ltd. strives to supply high-quality high-reliability products, however, any and all semiconductor products fail or malfunction with some probability. It is possible that these probabilistic failures or malfunction could give rise to accidents or events that could endanger human lives, trouble that could give rise to smoke or fire, or accidents that could cause damage to other property. When designing equipment, adopt safety measures so that these kinds of accidents or events cannot occur. Such measures include but are not limited to protective circuits and error prevention circuits for safe design, redundant design, and structural design.
- In the event that any or all SANYO Semiconductor Co.,Ltd. products described or contained herein are controlled under any of applicable local export control laws and regulations, such products may require the export license from the authorities concerned in accordance with the above law.
- No part of this publication may be reproduced or transmitted in any form or by any means, electronic or mechanical, including photocopying and recording, or any information storage or retrieval system, or otherwise, without the prior written consent of SANYO Semiconductor Co.,Ltd.
- Any and all information described or contained herein are subject to change without notice due to product/technology improvement, etc. When designing equipment, refer to the "Delivery Specification" for the SANYO Semiconductor Co.,Ltd. product that you intend to use.
- Upon using the technical information or products described herein, neither warranty nor license shall be granted with regard to intellectual property rights or any other rights of SANYO Semiconductor Co.,Ltd. or any third party. SANYO Semiconductor Co.,Ltd. shall not be liable for any claim or suits with regard to a third party's intellectual property rights which has resulted from the use of the technical information and products mentioned above.

This catalog provides information as of April, 2012. Specifications and information herein are subject to change without notice.



Компания «ЭлектроПласт» предлагает заключение долгосрочных отношений при поставках импортных электронных компонентов на взаимовыгодных условиях!

Наши преимущества:

- Оперативные поставки широкого спектра электронных компонентов отечественного и импортного производства напрямую от производителей и с крупнейших мировых складов;
- Поставка более 17-ти миллионов наименований электронных компонентов;
- Поставка сложных, дефицитных, либо снятых с производства позиций;
- Оперативные сроки поставки под заказ (от 5 рабочих дней);
- Экспресс доставка в любую точку России;
- Техническая поддержка проекта, помощь в подборе аналогов, поставка прототипов;
- Система менеджмента качества сертифицирована по Международному стандарту ISO 9001;
- Лицензия ФСБ на осуществление работ с использованием сведений, составляющих государственную тайну;
- Поставка специализированных компонентов (Xilinx, Altera, Analog Devices, Intersil, Interpoint, Microsemi, Aeroflex, Peregrine, Syfer, Eurofarad, Texas Instrument, Miteq, Cobham, E2V, MA-COM, Hittite, Mini-Circuits, General Dynamics и др.);

Помимо этого, одним из направлений компании «ЭлектроПласт» является направление «Источники питания». Мы предлагаем Вам помощь Конструкторского отдела:

- Подбор оптимального решения, техническое обоснование при выборе компонента;
- Подбор аналогов;
- Консультации по применению компонента;
- Поставка образцов и прототипов;
- Техническая поддержка проекта;
- Защита от снятия компонента с производства.



#### Как с нами связаться

**Телефон:** 8 (812) 309 58 32 (многоканальный)

**Факс:** 8 (812) 320-02-42

**Электронная почта:** [org@eplast1.ru](mailto:org@eplast1.ru)

**Адрес:** 198099, г. Санкт-Петербург, ул. Калинина, дом 2, корпус 4, литера А.