

CIRCUIT SIZE	DIM. "A"	DIM. "B"
2	—	—
4	.59 (15.0)	.165 (4.20)
6	.76 (19.2)	.331 (8.40)
8	.92 (23.4)	.496 (12.60)
10	1.09 (27.6)	.661 (16.80)
12	1.25 (31.8)	.827 (21.00)
14	1.42 (36.0)	.992 (25.20)
16	1.58 (40.2)	1.157 (29.40)
18	1.75 (44.4)	1.323 (33.60)
20	1.91 (48.6)	1.488 (37.80)
22	2.08 (52.8)	1.654 (42.00)
24	2.24 (57.0)	1.819 (46.20)

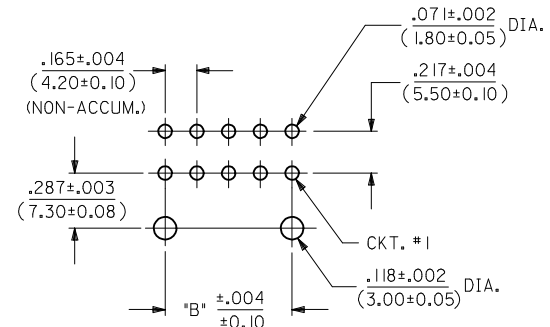

A-44499-*



- NOTES:
- MATERIAL:
HOUSING: "A" = NYLON 6/6, UL 94V-2, COLOR: NATURAL
"B" = NYLON 6/6, UL 94V-0, COLOR: NATURAL
TERMINALS: BRASS
 - TERMINAL PLATING:
C = .000030/(.00076) MIN. SELECT GOLD AND .000100/(.00254) MIN. MATTE TIN OVER .000050/(.00127) MIN. NICKEL OVERALL.
D = .000100/(.00254) MIN. MATTE TIN OVER .000050/(.00127) MIN. NICKEL OVERALL.
 - PRODUCT SPECIFICATION: PS-5556-002
 - PACKAGING: TRAY PACKED PER MOLEX SPECIFICATION PK-42404-002.
 - PART MATES WITH MINI-FIT JR. RECEPTACLE 5557, 42385, 42474 AND 44516. 2 CIRCUIT PARTS MATE WITH 42385, 42474, AND 44516 ONLY.
 - PART ALLOWS FOR UP TO .100/(2.54) MISALIGNMENT WITH MATING RECEPTACLE IN ANY DIRECTION. SEE MATING CONNECTOR DRAWINGS FOR SPECIFIC ALLOWANCES.
 - PART IS NOT DESIGNED FOR CURRENT SHARING.
 - CONNECTOR ASSEMBLIES ARE NOT TO BE MATED OR UNMATED WHILE CIRCUITS ARE LIVE.
 - CIRCUITS SHOWN PROVIDE THE "MAKE-FIRST/BREAK-LAST" FEATURE.
 - PART CONFORMS TO CLASS B OF COSMETIC SPECIFICATION PS-45499-002.
 - DISCOLORATION IN THE BANDOLIER CARRIER AREA OF THE PIN IS INHERENT TO THE PLATING PROCESS AND IS DUE TO THE MASKING EFFECT OF THE CARRIER. THIS DISCOLORATION IS IN A NON-FUNCTIONAL AREA OF THE PIN AND WILL NOT AFFECT THE PERFORMANCE OF THE HEADER ASSEMBLY.
 - FORMING MARKS ARE ACCEPTABLE

ADD 4499-0066 EC NO: UCP2015-3172 DRWINGB 2015/02/05 CHKD:IBELL 2015/02/05 APPR:FSMITH 2015/02/18	DESCRIPTION	QUALITY SYMBOLS	GENERAL TOLERANCES (UNLESS SPECIFIED)	DIMENSION STYLE	SCALE	DESIGN UNITS	THIRD ANGLE PROJECTION
		▽=0	mm INCH	IN/MM	2:1	METRIC	
D17	REV	▽=0	4 PLACES ± --- ± ---	DRAWN BY DATE	TITLE	DOCUMENT NO.	SHEET NO.
		▽=0	3 PLACES ± --- ± .010	AFG 1994/09/13			
		▽=0	2 PLACES ± 0.25 ± .015	CHECKED BY DATE			
		▽=0	1 PLACE ± 0.38 ± ---	RJF 1994/09/13			
			0 PLACE ± ±	APPROVED BY DATE			
			ANGULAR ±1/2°	FSMITH 2011/08/03			
			DRAFT WHERE APPLICABLE MUST REMAIN WITHIN DIMENSIONS	MATERIAL NO.			
				SEE CHART			
				SIZE C			
				THIS DRAWING CONTAINS INFORMATION THAT IS PROPRIETARY TO MOLEX. INCORPORATED AND SHOULD NOT BE USED WITHOUT WRITTEN PERMISSION			

ITEM NO.	CKT. SIZE	CHARACTERISTIC DESCRIPTION	LETTER INDICATES PIN PLATING AND LENGTH REQUIRED AT EACH CIRCUIT LOCATION, SEE NOTE 2 ON SHEET 1.																							
			1	2	3	4	5	6	7	8	9	10	11	12	13	14	15	16	17	18	19	20	21	22	23	24
44499-0113	24	24BD	DS	V	DS	V	DS	V	DS	V	V	DS	DS	DS	V	DS	V	DS	V	DS	V	V	DS	DS	DS	
44499-0114	14	14BD	DS	V	DS	V	DS	V	DS	DS	V	DS	V	DS	-	-	-	-	-	-	-	-	-	-	-	
44499-0115	18	18BD	DS	V	V	DS	V	V	DS	DS	DS	DS	V	V	DS	V	V	DS	DS	DS	-	-	-	-	-	
44499-0116	04	04BD	DS	DS	DM	DM	-	-	-	-	-	-	-	-	-	-	-	-	-	-	-	-	-	-		
44499-0117	10	10BD	DM	DM	DM	DM	DM	DM	DM	DM	DM	DM	-	-	-	-	-	-	-	-	-	-	-	-		
44499-0118	14	14BD	DM	DM	DM	DM	DM	DM	DM	DM	DM	DM	DM	DM	DM	-	-	-	-	-	-	-	-	-		
44499-0119	14	14BC	CM	CM	CM	CM	CS	CM	CS	CM	CM	CM	CM	CM	CS	-	-	-	-	-	-	-	-	-		
44499-0120	14	14BC	CM	CM	CM	CM	CS	CM	CM	CM	CM	CM	CM	CS	CM	CM	-	-	-	-	-	-	-	-		
44499-0121	10	10BC	CM	CS	CS	CS	CS	CM	CS	CS	CS	CS	-	-	-	-	-	-	-	-	-	-	-	-		
44499-0122	18	18BC	CM	CM	CM	CM	CM	CM	CM	CM	CM	CM	CM	CS	CS	CM	CM	CM	CM	CM	-	-	-	-	-	
44499-0123	10	10BD	DS	V	DS	V	DS	DS	V	DS	V	DS	-	-	-	-	-	-	-	-	-	-	-	-		
44499-0124	14	14BC	CM	CM	CM	CM	CM	CM	CM	CM	CS	CM	CM	CS	CM	CM	-	-	-	-	-	-	-	-		
44499-0125	14	14BC	CM	CM	CM	CM	CS	CM	CM	CM	CS	CM	CM	CM	CM	-	-	-	-	-	-	-	-	-		
44499-0126	14	14BC	CM	CM	CM	CM	CS	CM	CM	CM	CM	CM	CS	CS	CM	CM	-	-	-	-	-	-	-	-		
44499-0127	18	18BD	DM	DM	DM	DM	DM	DS	DS	DM	DS	DM	DM	DM	DM	DM	DM	DM	DM	-	-	-	-	-		
44499-0128	14	14BC	CM	CM	CM	CS	CS	CM	CS	CM	CM	CM	CS	CM	CM	CS	-	-	-	-	-	-	-	-		
44499-0129	14	14BD	DM	DM	DM	DS	DS	DM	DS	DM	DM	DM	DS	DS	DM	DS	-	-	-	-	-	-	-	-		

CHARACTERISTICS LEGEND:

CIRCUIT SIZE (02-24) **** * ***

HOUSING MATERIAL **** * ***

A = NYLON 6/6, U.L. 94V-2, COLOR: NATURAL
 B = NYLON 6/6, U.L. 94V-0, COLOR: NATURAL

TERMINAL PLATING **** * ***

C = SELECT GOLD
 D = MATTE TIN OVERALL
 * = MIXED TIN AND GOLD

TERMINAL PLATING AND LENGTH CODE

CS = SELECT GOLD, STANDARD LENGTH
 DS = MATTE TIN, STANDARD LENGTH
 CM = SELECT GOLD, MATE-FIRST/BREAK-LAST (LONGER)
 DM = MATTE TIN, MATE-FIRST/BREAK-LAST (LONGER)
 V = VOID CIRCUIT

SEE SHEET 1 EC NO: UCP2015-3172 DRWNG: 2015/02/05 CHKD: JBELL 2015/02/05 APPR: FSMITH 2015/02/18	QUALITY SYMBOLS	GENERAL TOLERANCES (UNLESS SPECIFIED)	DIMENSION STYLE	SCALE	DESIGN UNITS	THIRD ANGLE PROJECTION
	▽=0	mm INCH	IN/MM	1:1	METRIC	
	▽=0	4 PLACES ± --- ± ---	DRAWN BY DATE	TITLE		
	▽=0	3 PLACES ± --- ±.010	AFG 1994/09/13	SELECTIVELY-LOADED RT ANGLE DUAL ROW HEADER (MATE-FIRST/BREAK-LAST)		
	2 PLACES ±0.25 ±.015	CHECKED BY DATE	molex			
	1 PLACE ±0.38 ± ---	RJF 1994/09/13	SDA-44499-*			
	0 PLACE ± ±	APPROVED BY DATE	SHEET NO. 3 OF 3			
	ANGULAR ±1/2°	FSMITH 2011/08/03	INCORPORATED AND SHOULD NOT BE USED WITHOUT WRITTEN PERMISSION			
	DRAFT WHERE APPLICABLE MUST REMAIN WITHIN DIMENSIONS	MATERIAL NO.				
D17		SIZE				



Компания «ЭлектроПласт» предлагает заключение долгосрочных отношений при поставках импортных электронных компонентов на взаимовыгодных условиях!

Наши преимущества:

- Оперативные поставки широкого спектра электронных компонентов отечественного и импортного производства напрямую от производителей и с крупнейших мировых складов;
- Поставка более 17-ти миллионов наименований электронных компонентов;
- Поставка сложных, дефицитных, либо снятых с производства позиций;
- Оперативные сроки поставки под заказ (от 5 рабочих дней);
- Экспресс доставка в любую точку России;
- Техническая поддержка проекта, помощь в подборе аналогов, поставка прототипов;
- Система менеджмента качества сертифицирована по Международному стандарту ISO 9001;
- Лицензия ФСБ на осуществление работ с использованием сведений, составляющих государственную тайну;
- Поставка специализированных компонентов (Xilinx, Altera, Analog Devices, Intersil, Interpoint, Microsemi, Aeroflex, Peregrine, Syfer, Eurofarad, Texas Instrument, Miteq, Cobham, E2V, MA-COM, Hittite, Mini-Circuits, General Dynamics и др.);

Помимо этого, одним из направлений компании «ЭлектроПласт» является направление «Источники питания». Мы предлагаем Вам помощь Конструкторского отдела:

- Подбор оптимального решения, техническое обоснование при выборе компонента;
- Подбор аналогов;
- Консультации по применению компонента;
- Поставка образцов и прототипов;
- Техническая поддержка проекта;
- Защита от снятия компонента с производства.



Как с нами связаться

Телефон: 8 (812) 309 58 32 (многоканальный)

Факс: 8 (812) 320-02-42

Электронная почта: org@eplast1.ru

Адрес: 198099, г. Санкт-Петербург, ул. Калинина, дом 2, корпус 4, литера А.