

High voltage high and low-side driver

Datasheet - production data

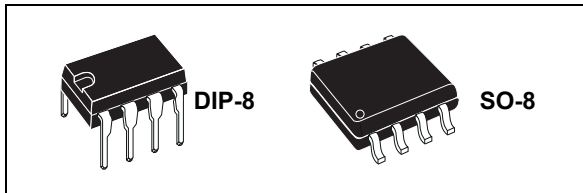

Features

- High voltage rail up to 600 V
- dV/dt immunity ± 50 V/nsec in full temperature range
- Driver current capability:
 - 400 mA source
 - 650 mA sink
- Switching times 70/40 nsec rise/fall with 1 nF load
- 3.3 V, 5 V, 15 V CMOS/TTL input comparators with hysteresis and pull-down
- Internal bootstrap diode
- Outputs in phase with inputs
- Deadtime and interlocking function

Applications

- Home appliances
- Industrial applications and drives
- Motor drivers
 - DC, AC, PMDC and PMAC motors
- Induction heating
- HVAC
- Factory automation
- Lighting applications
- Power supply systems

Description

The L6388E is a high voltage gate driver, manufactured with the BCD™ “offline” technology, and able to drive a half-bridge of power MOSFET/IGBT devices. The high-side (floating) section is enabled to work with voltage rail up to 600 V. Both device outputs can sink and source 650 mA and 400 mA respectively and cannot be simultaneously driven high thanks to an integrated interlocking function. Further prevention from outputs cross conduction is guaranteed by the deadtime function.

The L6388E device has two input and two output pins, and guarantees the outputs switch in phase with inputs. The logic inputs are CMOS/TTL compatible (3.3 V, 5 V and 15 V) to ease the interfacing with controlling devices.

The bootstrap diode is integrated in the driver allowing a more compact and reliable solution.

The L6388E device features the UVLO protection on both supply voltages (V_{CC} and V_{BOOT}) ensuring greater protection against voltage drops on the supply lines.

The device is available in a DIP-8 tube and SO-8 tube, and tape and reel packaging options.

Contents

1	Block diagram	3
2	Electrical data	4
2.1	Absolute maximum ratings	4
2.2	Thermal data	4
2.3	Recommended operating conditions	4
3	Pin connection	5
4	Electrical characteristics	6
4.1	AC operation	6
4.2	DC operation	6
5	Waveform definitions	8
6	Input logic	9
7	Bootstrap driver	9
	C _{BOOT} selection and charging	9
8	Typical characteristics	11
9	Package information	13
9.1	DIP-8 package information	13
9.2	SO-8 package information	15
10	Order codes	16
11	Revision history	17

1 Block diagram

Figure 1. Block diagram

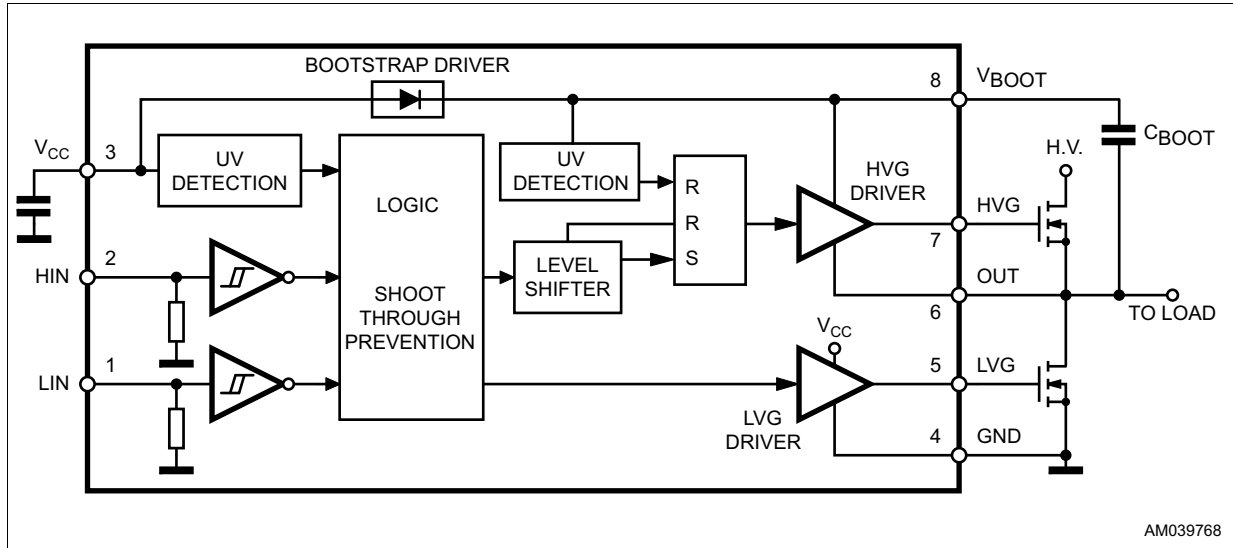

2 Electrical data

2.1 Absolute maximum ratings

Table 1. Absolute maximum ratings

Symbol	Parameter	Value		Unit
		Min.	Max.	
V_{OUT}	Output voltage	$V_{BOOT} - 18$	V_{BOOT}	V
V_{CC}	Supply voltage	- 0.3	18	V
V_{BOOT}	Floating supply voltage	- 0.3	618	V
V_{hvg}	High-side gate output voltage	$V_{OUT} - 0.3$	V_{BOOT}	V
V_{lvg}	Low-side gate output voltage	-0.3	$V_{CC} + 0.3$	V
V_i	Logic input voltage	-0.3	$V_{CC} + 0.3$	V
dV_{OUT}/dt	Allowed output slew rate		50	V/ns
P_{tot}	Total power dissipation ($T_J = 85\text{ °C}$)	750	750	mW
T_j	Junction temperature	150	150	°C
T_s	Storage temperature	-50	150	°C
ESD	Human body model	2		kV

2.2 Thermal data

Table 2. Thermal data

Symbol	Parameter	SO-8	DIP-8	Unit
$R_{th(JA)}$	Thermal resistance junction to ambient	150	100	°C/W

2.3 Recommended operating conditions

Table 3. Recommended operating conditions

Symbol	Pin	Parameter	Test condition	Min.	Typ.	Max.	Unit
V_{OUT}	6	Output voltage		(1)		580	V
$V_{BS}^{(2)}$	8	Floating supply voltage		(1)		17	V
f_{sw}		Switching frequency	HVG, LVG load $C_L = 1\text{ nF}$			400	kHz
V_{CC}	3	Supply voltage				17	V
T_J		Junction temperature		-45		125	°C

1. If the condition $V_{BOOT} - V_{OUT} < 18\text{ V}$ is guaranteed, V_{OUT} can range from -3 to 580 V.

2. $V_{BS} = V_{BOOT} - V_{OUT}$.

3 Pin connection

Figure 2. Pin connection (top view)

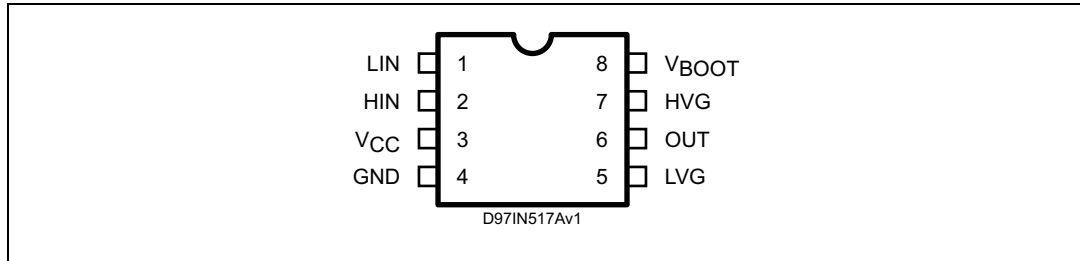

Table 4. Pin description

No.	Pin	Type	Function
1	LIN	I	Low-side driver logic input
2	HIN	I	High-side driver logic input
3	V _{CC}	P	Low-voltage power supply
4	GND	P	Ground
5	LVG ⁽¹⁾	O	Low-side driver output
6	OUT	P	High-side driver floating reference
7	HVG ⁽¹⁾	O	High-side driver output
8	V _{BOOT}	P	Bootstrap supply voltage

1. The circuit guarantees 0.3 V maximum on the pin (at $I_{\text{sink}} = 10 \text{ mA}$). This allows the omission of the "bleeder" resistor connected between the gate and the source of the external MOSFET normally used to hold the pin low.

4 Electrical characteristics

4.1 AC operation

Table 5. AC operation electrical characteristics ($V_{CC} = 15\text{ V}$; $T_J = 25\text{ °C}$)

Symbol	Pin	Parameter	Test condition	Min.	Typ.	Max.	Unit
t_{on}	1 vs. 5	High/low-side driver turn-on propagation delay	$V_{OUT} = 0\text{ V}$		225	300	ns
t_{off}	2 vs. 7	High/low-side driver turn-off propagation delay	$V_{OUT} = 0\text{ V}$		160	220	ns
t_r	5, 7	Rise time	$C_L = 1000\text{ pF}$		70	100	ns
t_f	5, 7	Fall time	$C_L = 1000\text{ pF}$		40	80	ns
DT	5, 7	Deadtime		220	320	420	ns

4.2 DC operation

Table 6. DC operation electrical characteristics

Symbol	Pin	Parameter	Test condition	Min.	Typ.	Max.	Unit
Low supply voltage section							
V_{CCth1}	3	V_{CC} UV turn-on threshold		9.1	9.6	10.1	V
V_{CCth2}		V_{CC} UV turn-off threshold		7.9	8.3	8.8	V
V_{CCchys}		V_{CC} UV hysteresis		0.9			V
I_{QCCU}		Undervoltage quiescent supply current	$V_{CC} \leq 9\text{ V}$		250	330	μA
I_{QCC}		Quiescent current	$V_{CC} = 15\text{ V}$		350	450	μA
$R_{DS(on)}$		Bootstrap driver on resistance ⁽¹⁾	$V_{CC} \geq 12.5\text{ V}$		125		Ω
Bootstrapped supply voltage section							
V_{BSth1}	8	V_{BS} UV turn-on threshold		8.5	9.5	10.5	V
V_{BSth2}		V_{BS} UV turn-off threshold		7.2	8.2	9.2	V
V_{BSchys}		V_{BS} UV hysteresis		0.9			V
I_{QBS}		V_{BS} quiescent current	HVG ON			250	μA
I_{LK}		High voltage leakage current	$V_{hvg} = V_{OUT} = V_{BOOT} = 600\text{ V}$			10	μA
High/low-side driver							
I_{so}	5, 7	Source short-circuit current	$V_{IN} = V_{ih} (t_p < 10\text{ }\mu\text{s})$	300	400		mA
I_{si}		Sink short-circuit current	$V_{IN} = V_{il} (t_p < 10\text{ }\mu\text{s})$	500	650		mA

Table 6. DC operation electrical characteristics (continued)

Symbol	Pin	Parameter	Test condition	Min.	Typ.	Max.	Unit
Logic inputs							
V_{il}	1, 2	Low logic level input voltage				1.1	V
V_{ih}		High logic level input voltage		1.8			V
I_{ih}		High logic level input current	$V_{IN} = 15\text{ V}$		20	70	μA
I_{il}		Low logic level input current	$V_{IN} = 0\text{ V}$	-1			μA

1. $R_{DS(on)}$ is tested in the following way:

$$R_{DS(on)} = \frac{(V_{CC} - V_{BOOT1}) - (V_{CC} - V_{BOOT2})}{I_1(V_{CC}, V_{BOOT1}) - I_2(V_{CC}, V_{BOOT2})}$$

where:

I_1 is pin 8 current when $V_{BOOT} = V_{BOOT1}$, I_2 when $V_{BOOT} = V_{BOOT2}$.

5 Waveform definitions

Figure 3. Deadtime time waveform definition

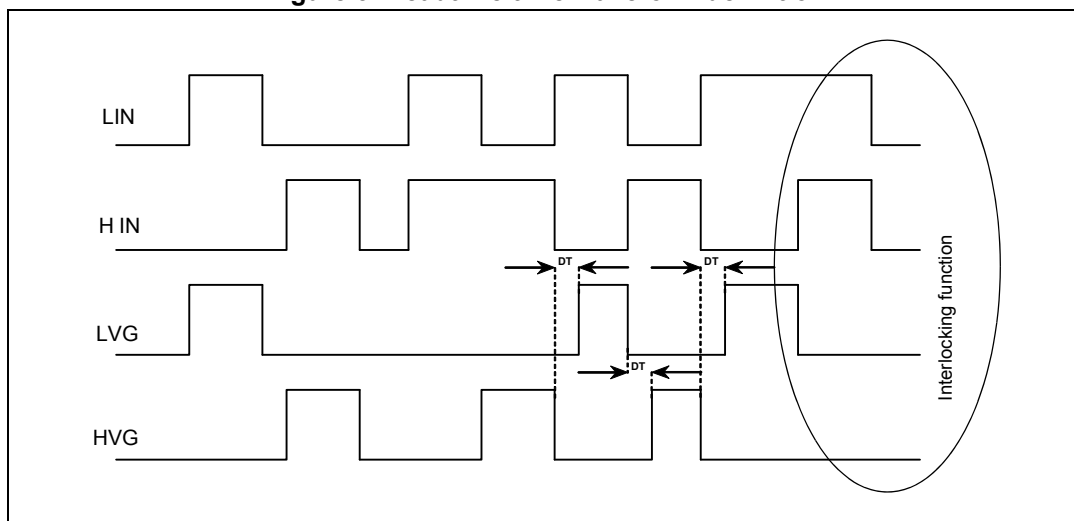
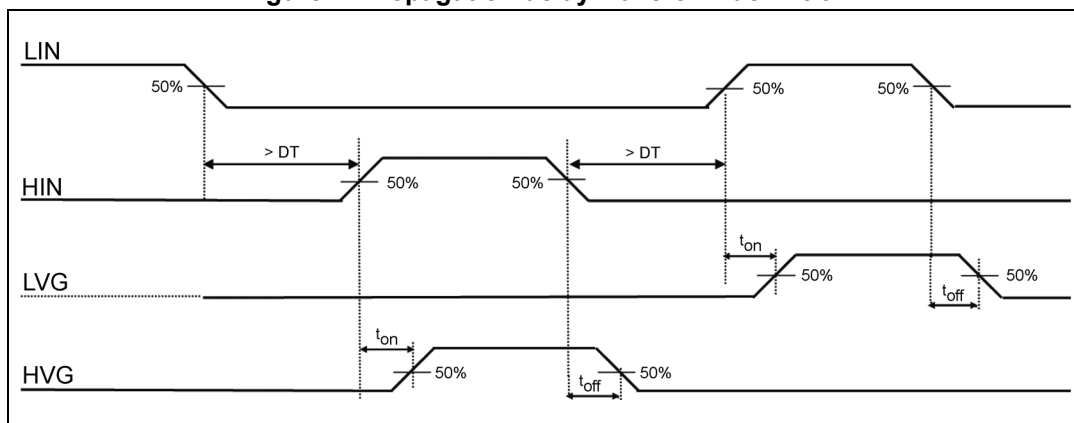

Figure 4. Propagation delay waveform definition



6 Input logic

Input logic is provided with an interlocking circuitry which avoids the two outputs (LVG, HVG) being active at the same time when both the logic input pins (LIN, HIN) are at a high logic level. In addition, to prevent cross conduction of the external MOSFETs, after each output is turned off, the other output cannot be turned on before a certain amount of time (DT) (see [Figure 3](#)).

7 Bootstrap driver

A bootstrap circuitry is needed to supply the high voltage section. This function is normally accomplished by a high voltage fast recovery diode ([Figure 5 a](#)). In the L6388E device, a patented integrated structure replaces the external diode. It is realized by a high voltage DMOS, driven synchronously with the low-side driver (LVG), with a diode in series, as shown in [Figure 5 b](#). An internal charge pump ([Figure 5 b](#)) provides the DMOS driving voltage. The diode connected in series to the DMOS has been added to avoid an undesirable turn-on.

C_{BOOT} selection and charging

To choose the proper C_{BOOT} value, the external MOSFET can be seen as an equivalent capacitor. This capacitor C_{EXT} is related to the MOSFET total gate charge:

Equation 1

$$C_{EXT} = \frac{Q_{gate}}{V_{gate}}$$

The ratio between the capacitors C_{EXT} and C_{BOOT} is proportional to the cyclical voltage loss. It must be:

$$C_{BOOT} \gg C_{EXT}$$

E.g.: if Q_{gate} is 30 nC and V_{gate} is 10 V, C_{EXT} is 3 nF. With $C_{BOOT} = 100$ nF the drop is 300 mV.

If HVG must be supplied for a long period, the C_{BOOT} selection must also take the leakage losses into account.

E.g.: HVG steady-state consumption is typical 250 μ A, so, if HVG T_{ON} is 5 ms, C_{BOOT} must supply 1.25 μ C to C_{EXT} . This charge on a 1 μ F capacitor means a voltage drop of 1.25 V.

The internal bootstrap driver offers important advantages: the external fast recovery diode can be avoided (it usually has a high leakage current).

This structure can work only if V_{OUT} is close to GND (or lower) and, at the same time, the LVG is on. The charging time (T_{charge}) of the C_{BOOT} is the time in which both conditions are fulfilled and it must be long enough to charge the capacitor.

The bootstrap driver introduces a voltage drop due to the DMOS $R_{DS(on)}$ (typical value: 125 Ω). This drop can be neglected at low switching frequency, but it should be taken into account when operating at high switching frequency.

The following equation is useful to compute the drop on the bootstrap DMOS:

Equation 2

$$V_{\text{drop}} = I_{\text{charge}} R_{\text{dson}} \rightarrow V_{\text{drop}} = \frac{Q_{\text{gate}}}{T_{\text{charge}}} R_{\text{dson}}$$

where Q_{gate} is the gate charge of the external power MOSFET, $R_{\text{DS(on)}}$ is the on-resistance of the bootstrap DMOS, and T_{charge} is the charging time of the bootstrap capacitor.

For example: using a power MOSFET with a total gate charge of 30 nC, the drop on the bootstrap DMOS is about 1 V, if the T_{charge} is 5 μs .

In fact:

Equation 3

$$V_{\text{drop}} = \frac{30\text{nC}}{5\mu\text{s}} \cdot 125\Omega \sim 0.8\text{V}$$

V_{drop} should be taken into account when the voltage drop on C_{BOOT} is calculated: if this drop is too high, or the circuit topology doesn't allow a sufficient charging time, an external diode can be used.

Figure 5. Bootstrap driver

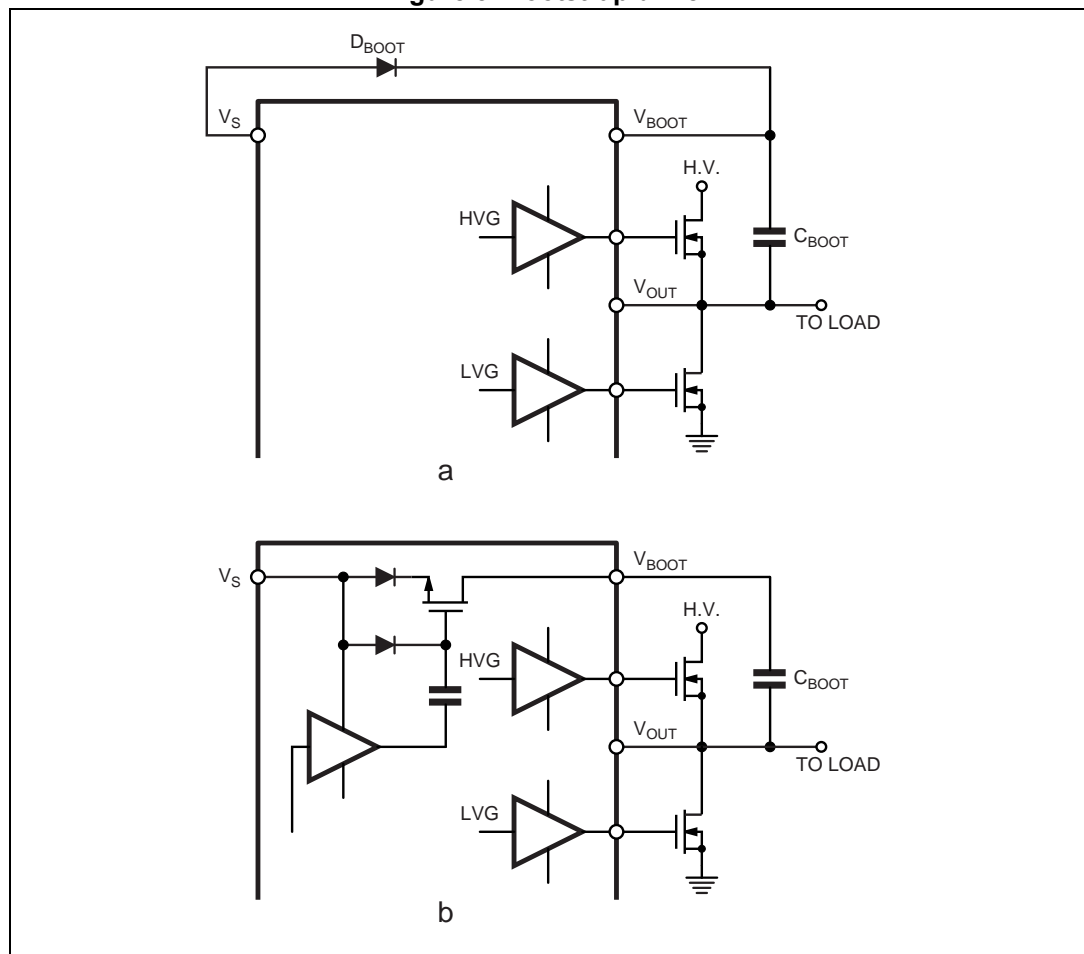

8 Typical characteristics

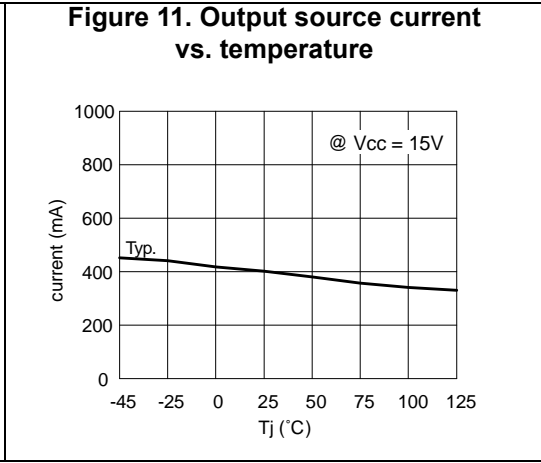
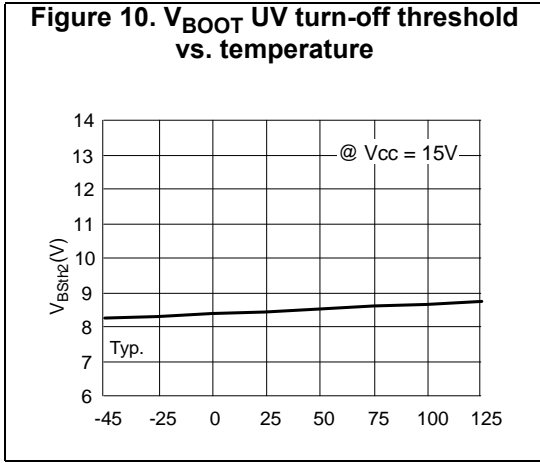
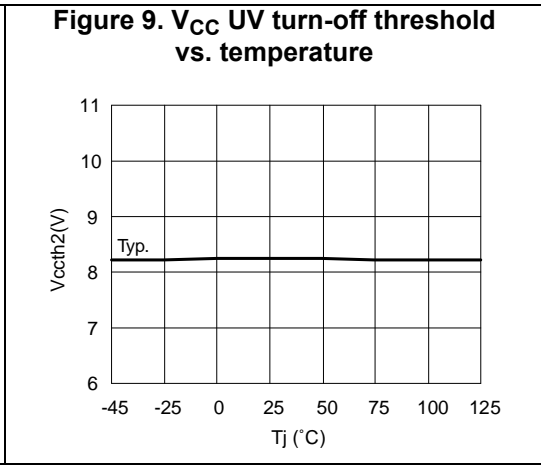
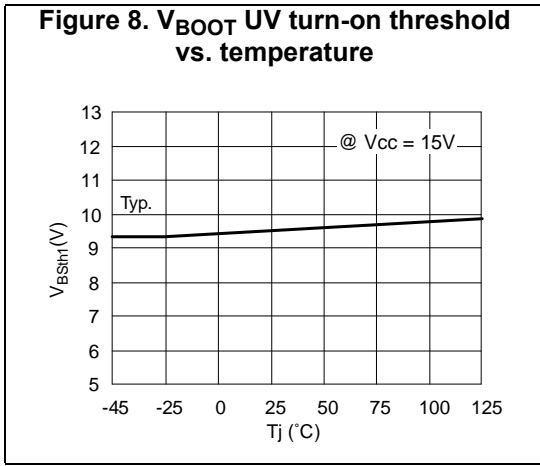
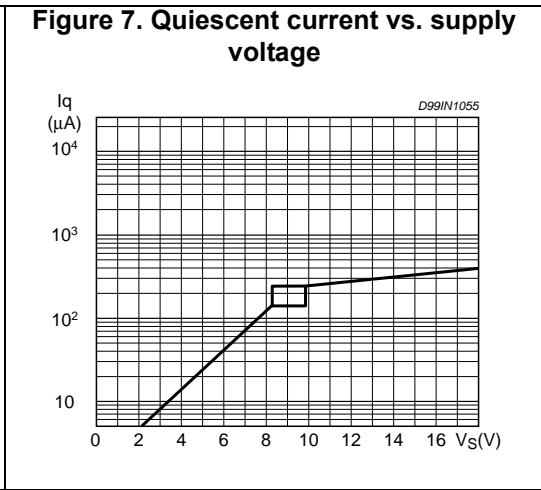
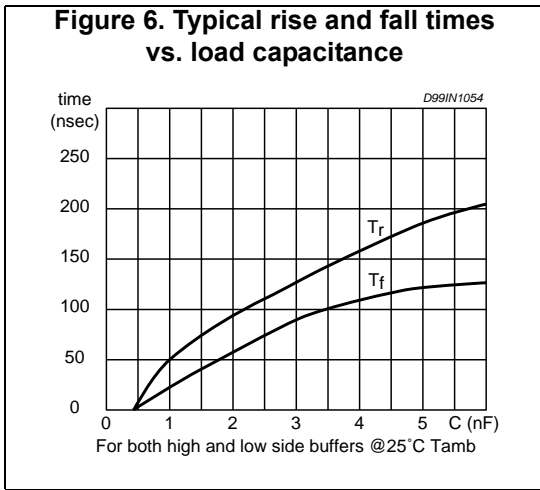

Figure 12. V_{CC} UV turn-on threshold vs. temperature

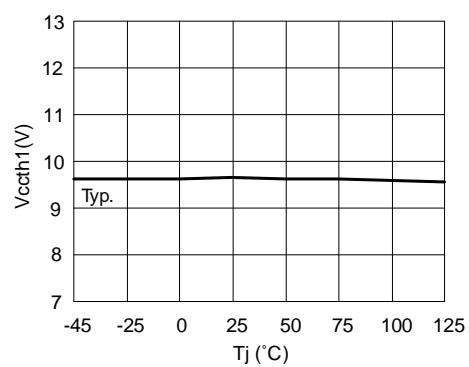
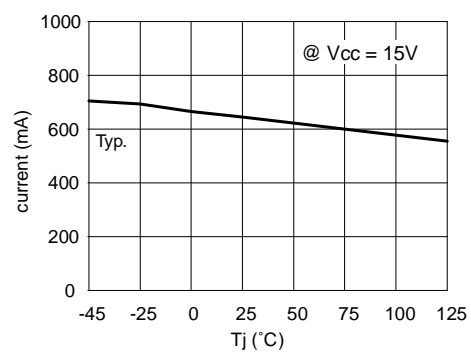

Figure 13. Output sink current vs. temperature



9 Package information

In order to meet environmental requirements, ST offers these devices in different grades of ECOPACK® packages, depending on their level of environmental compliance. ECOPACK specifications, grade definitions and product status are available at: www.st.com. ECOPACK is an ST trademark.

9.1 DIP-8 package information

Figure 14. DIP-8 package outline

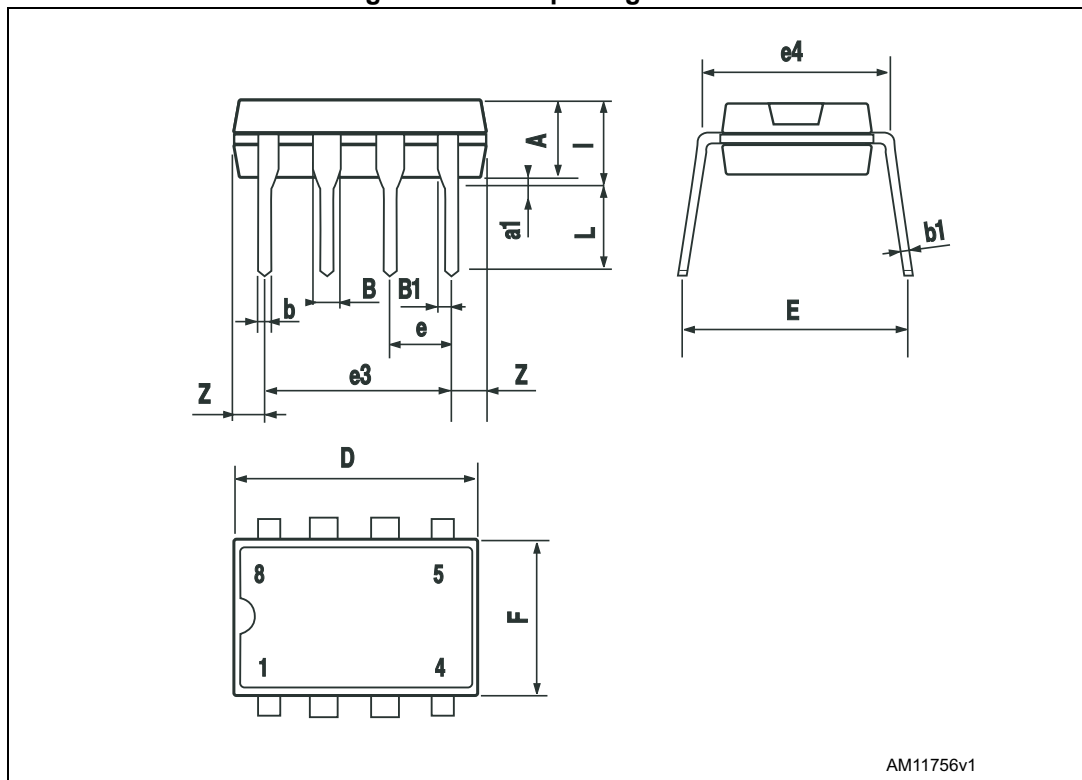

Table 7. DIP-8 package mechanical data

Symbol	Dimensions (mm)		
	Min.	Typ.	Max.
A		3.32	
a1	0.51		
B	1.15		1.65
b	0.356		0.55
b1	0.204		0.304
D			10.92
E	7.95		9.75
e		2.54	
e3		7.62	
e4		7.62	
F			6.6
I			5.08
L	3.18		3.81
Z			1.52

9.2 SO-8 package information

Figure 15. SO-8 package outline

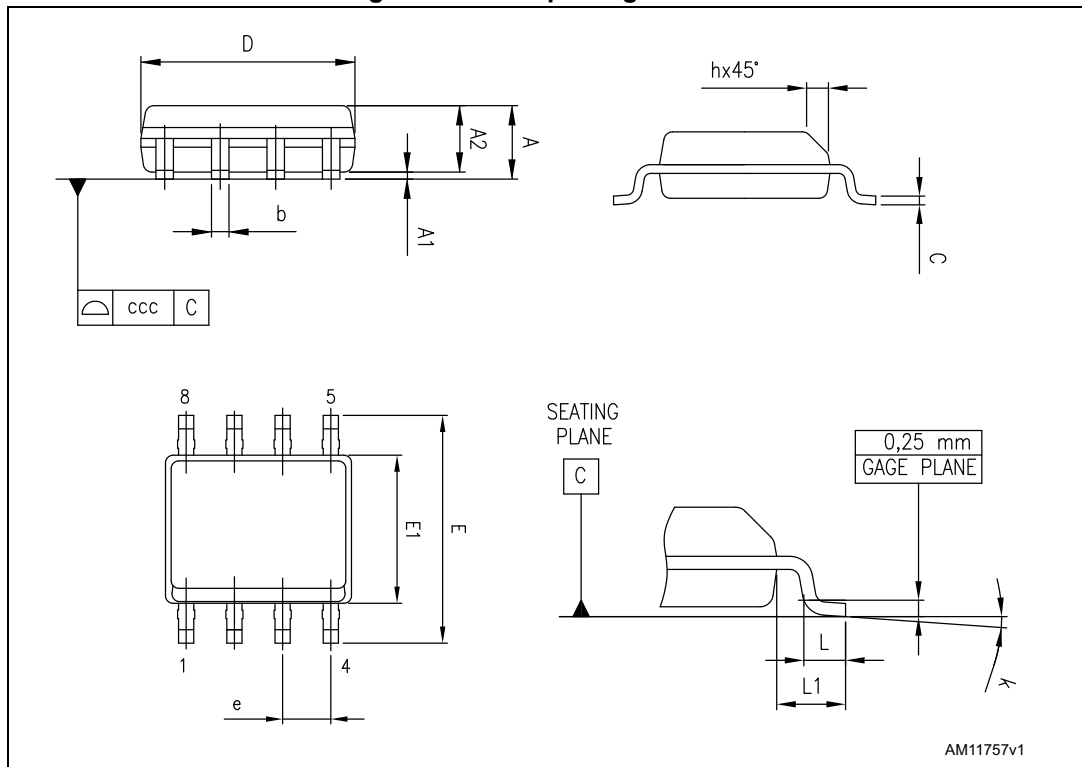

Table 8. SO-8 package mechanical data

Symbol	Dimensions (mm)		
	Min.	Typ.	Max.
A			1.75
A1	0.10		0.25
A2	1.25		
b	0.28		0.48
c	0.17		0.23
D	4.80	4.90	5.00
E	5.80	6.00	6.20
E1	3.80	3.90	4.00
e		1.27	
h	0.25		0.50
L	0.40		1.27
L1		1.04	
k	0°		8°
ccc			0.10

10 Order codes

Table 9. Order codes

Part number	Package	Packaging
L6388E	DIP-8	Tube
L6388ED	SO-8	Tube
L6388ED013TR	SO-8	Tape and reel

11 Revision history

Table 10. Document revision history

Date	Revision	Changes
11-Oct-2007	1	First release
29-Feb-2012	2	Updated Table 2 , Table 7 and Section 6.1 . DIP-8 mechanical data and package dimensions have been updated. SO-8 mechanical data and package dimensions have been updated.
31-Jan-2013	3	Update note in Section 2.1 .
19-Jun-2014	4	Added Section : Applications on page 1 . Updated Section : Description on page 1 (replaced by new description). Updated Table 1: Device summary on page 1 (moved from page 17 to page 1, renamed title of Table 1). Updated Figure 1: Block diagram on page 3 (moved from page 1 to page 3, added Section 1: Block diagram on page 3). Updated Section 2.1: Absolute maximum ratings on page 4 (removed note below Table 2: Absolute maximum ratings). Updated Table 5: Pin description on page 5 (added "Type" for several pins). Updated Section 9: Package information on page 14 (added/updated titles, reversed order of Figure 14 and Table 8 , Figure 15 and Table 9 minor modifications). Minor modifications throughout document.
21-Oct-2015	5	Updated Table 1 on page 4 (added ESD row). Updated note 1 . below Table 6 on page 6 (replaced V_{BOOTx} by V_{BOOTx}). Added Section 10: Order codes on page 16 (moved Table 9 from page 1, updated title). Minor modifications throughout document.

IMPORTANT NOTICE – PLEASE READ CAREFULLY

STMicroelectronics NV and its subsidiaries (“ST”) reserve the right to make changes, corrections, enhancements, modifications, and improvements to ST products and/or to this document at any time without notice. Purchasers should obtain the latest relevant information on ST products before placing orders. ST products are sold pursuant to ST’s terms and conditions of sale in place at the time of order acknowledgement.

Purchasers are solely responsible for the choice, selection, and use of ST products and ST assumes no liability for application assistance or the design of Purchasers’ products.

No license, express or implied, to any intellectual property right is granted by ST herein.

Resale of ST products with provisions different from the information set forth herein shall void any warranty granted by ST for such product.

ST and the ST logo are trademarks of ST. All other product or service names are the property of their respective owners.

Information in this document supersedes and replaces information previously supplied in any prior versions of this document.

© 2015 STMicroelectronics – All rights reserved



Компания «ЭлектроПласт» предлагает заключение долгосрочных отношений при поставках импортных электронных компонентов на взаимовыгодных условиях!

Наши преимущества:

- Оперативные поставки широкого спектра электронных компонентов отечественного и импортного производства напрямую от производителей и с крупнейших мировых складов;
- Поставка более 17-ти миллионов наименований электронных компонентов;
- Поставка сложных, дефицитных, либо снятых с производства позиций;
- Оперативные сроки поставки под заказ (от 5 рабочих дней);
- Экспресс доставка в любую точку России;
- Техническая поддержка проекта, помощь в подборе аналогов, поставка прототипов;
- Система менеджмента качества сертифицирована по Международному стандарту ISO 9001;
- Лицензия ФСБ на осуществление работ с использованием сведений, составляющих государственную тайну;
- Поставка специализированных компонентов (Xilinx, Altera, Analog Devices, Intersil, Interpoint, Microsemi, Aeroflex, Peregrine, Syfer, Eurofarad, Texas Instrument, Miteq, Cobham, E2V, MA-COM, Hittite, Mini-Circuits, General Dynamics и др.);

Помимо этого, одним из направлений компании «ЭлектроПласт» является направление «Источники питания». Мы предлагаем Вам помощь Конструкторского отдела:

- Подбор оптимального решения, техническое обоснование при выборе компонента;
- Подбор аналогов;
- Консультации по применению компонента;
- Поставка образцов и прототипов;
- Техническая поддержка проекта;
- Защита от снятия компонента с производства.



Как с нами связаться

Телефон: 8 (812) 309 58 32 (многоканальный)

Факс: 8 (812) 320-02-42

Электронная почта: org@eplast1.ru

Адрес: 198099, г. Санкт-Петербург, ул. Калинина, дом 2, корпус 4, литера А.