

NOTES:

1. ALL DIMENSIONS ARE IN  $\frac{\text{INCHES}}{[\text{MILLIMETERS}]}$ ;  $\frac{\text{LBS}}{[\text{GRAMS}]}$

2. DIMENSIONS APPEARING IN TABLE ARE AS FOLLOWS:  
 a AS SUPPLIED  
 b AFTER UNRESTRICTED RECOVERY

3. COATING (ADHESIVE) IS OPTIONAL. AS SUPPLIED DIMENSIONS APPEARING IN TABLE ARE FOR UNCOATED PARTS. WHEN COATING IS ADDED, ENTRY DIAMETERS WILL BE REDUCED BY .06 MAX.

4. MOLDING PORTS ARE OPTIONAL. WHEN -00 MODIFICATION NUMBER IS SPECIFIED MOLDING PORTS WILL BE LOCATED AS SHOWN.

ON SIZES 222A111 AND 222A121 THE 0.18 INCH DIAMETER MOLDING PORT AT "T" WILL BE ELIMINATED. THE 0.12" DIA MOLDING PORT WILL BE ENLARGED TO 0.18 INCHES

5. WEIGHT SHOWN IN TABLE OF DIMENSIONS IS BASED ON POLYOLEFIN PART

6. ORDERING INFORMATION 222A1XX -XX -XX /XXX /0

BASE PART NUMBER

MATERIAL DASH NUMBER

- 3 POLYOLEFIN, SEMI RIGID (RT-301)
- 4 POLYOLEFIN, FLEXIBLE (RT-1304)
- 5 ELASTOMER, FLEXIBLE (RT-501)
- 6 SILICONE (RT-602)
- 8 POLYOLEFIN, SPACE (RT-1308)
- 12 FLUORO ELASTOMER, FLEXIBLE (RT-1312)
- 25 ELASTOMER, FLUID RESISTANT (RT-1325)
- 100 POLYOLEFIN, SEMI-FLEXIBLE ZEROHAL (RT-1323)

MODIFICATION NUMBER

ADHESIVE SLASH NUMBER

SEE COMPATIBILITY CHART BELOW

COLOR DESIGNATOR

IF THIS DOCUMENT IS PRINTED IT BECOMES UNCONTROLLED. CHECK FOR THE LATEST REVISION.

COMPATIBILITY CHART

MATERIAL DASH NO.	ADHESIVE (COATING) SLASH NO.	ADHESIVE (COATING) S NO.
-3; -4	/42; /86	S-1017; S-1048;
-5	/42	S-1017
-6; -8; -12	NOT APPLICABLE	N/A
-25	/42; /86; /225	S-1017; S-1048; S-1206
-100	/86; /180; /184	S-1017; S-1030

REVISIONS		
LTR	DESCRIPTION	DATE
U1	REVISED PER ECO-11-005139	29MAR11

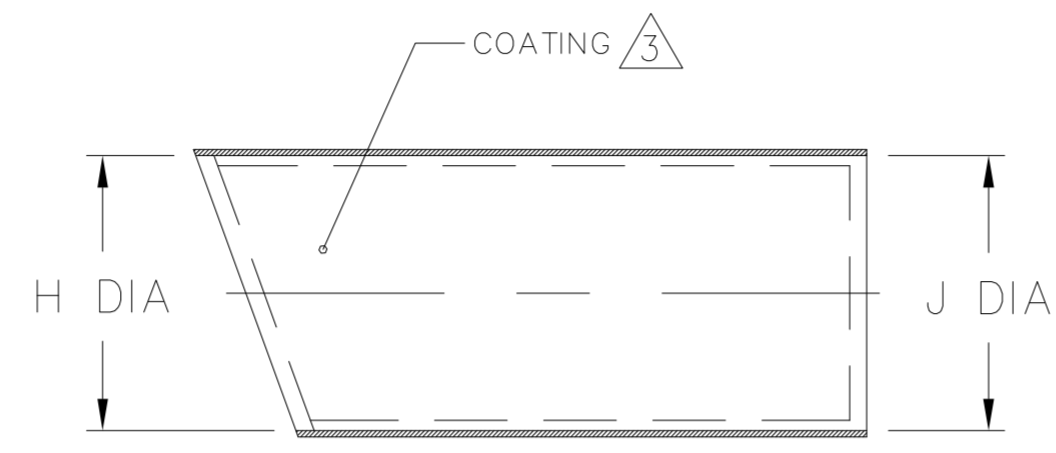

AS SUPPLIED

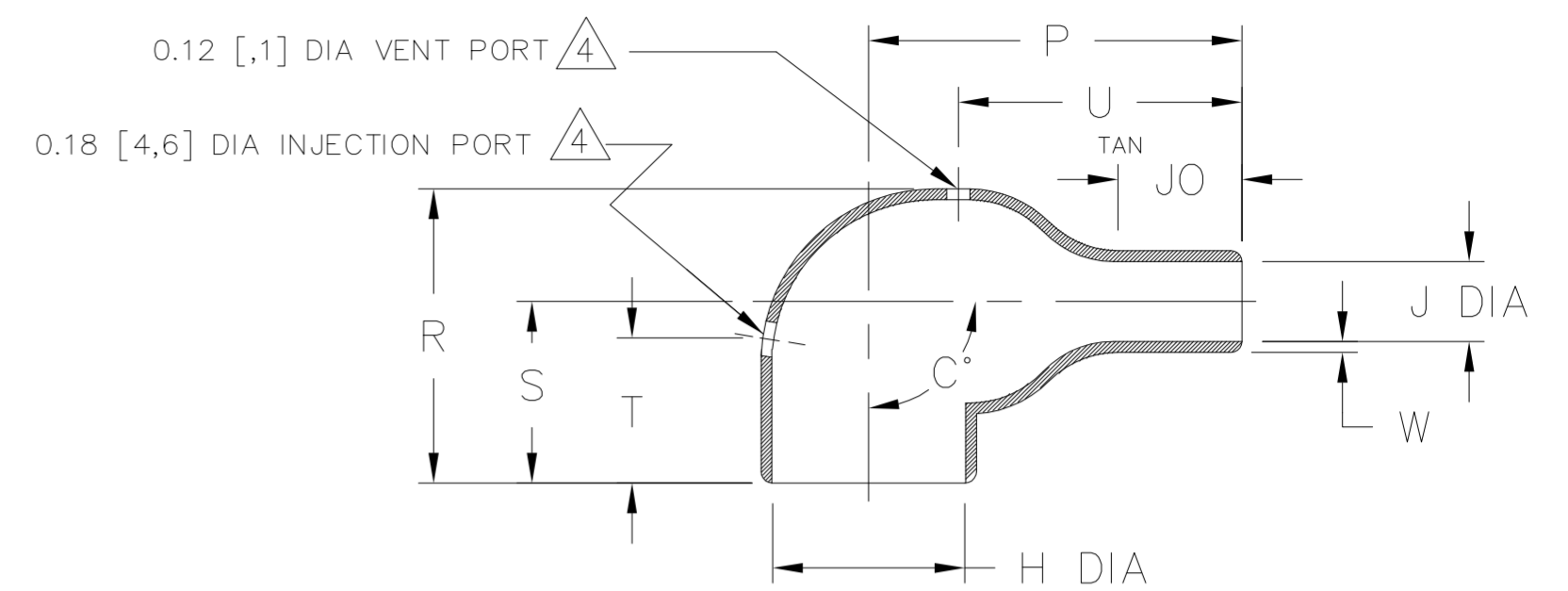

AFTER UNRESTRICTED RECOVERY

TABLE OF DIMENSIONS

PART DESCRIPTION	H			J				P	R	S	T	U	JO	W	C°		WEIGHT REF
	MIN -3,-4,-5,-6 -12,-25,-100 a	MIN -8 a	MAX b	MIN -3,-4 -6,-25 a	MIN -5,-8 -100 a	MIN -12 a	MAX b	±10% b	±10% b	±10% b	±10% b	±10% b	±10% b	±20% b	±10% a	±5% b	b
222A111	.70 [17,8]	.43 [10,9]	.31 [7,9]	.70 [17,8]	.43 [10,9]	.39 [9,9]	.15 [3,8]	.68 [17,3]	.79 [20,1]	.61 [15,5]	N/A	.45 [11,4]	.17 [4,3]	.04 [1,02]	180	90	.002 [0,91]
222A121	.98 [24,9]	.63 [16,0]	.40 [10,2]	.98 [24,9]	.63 [16,0]	.71 [18,0]	.21 [5,3]	.84 [21,3]	.89 [22,6]	.65 [16,5]	N/A	.58 [14,7]	.23 [5,8]	.05 [1,3]	180	90	.003 [1,36]
222A132	1.18 [30,0]	.83 [21,1]	.56 [14,2]	1.18 [30,0]	.83 [21,1]	.81 [20,6]	.25 [6,4]	1.06 [26,9]	1.05 [26,7]	.73 [18,5]	.75 [19,1]	.70 [17,8]	.28 [7,1]	.06 [1,5]	180	90	.006 [2,72]
222A142	1.28 [32,5]	.90 [22,9]	.68 [17,3]	1.28 [32,5]	.90 [22,9]	.90 [22,9]	.27 [6,9]	1.44 [36,6]	1.20 [30,5]	.81 [20,6]	.75 [19,1]	.98 [24,9]	.40 [10,2]	.07 [1,8]	180	90	.014 [6,35]
222A152	1.42 [36,1]	1.08 [27,4]	.86 [21,8]	1.42 [36,1]	1.08 [27,4]	1.04 [26,4]	.33 [8,4]	1.72 [43,7]	1.38 [35,1]	.90 [22,9]	.75 [19,1]	1.18 [30,0]	.50 [12,7]	.07 [1,8]	180	90	.019 [8,62]
222A163	1.73 [43,9]	1.12 [28,4]	1.08 [27,4]	1.73 [43,9]	1.12 [28,4]	1.08 [27,4]	.37 [9,4]	2.11 [53,6]	1.73 [43,9]	1.15 [29,2]	.75 [19,1]	1.34 [34,0]	.68 [17,3]	.08 [2,0]	180	90	.029 [13,15]
222A174	2.09 [53,1]	1.90 [48,3]	1.33 [33,8]	2.09 [53,1]	1.90 [48,3]	1.84 [46,7]	.59 [15,0]	2.98 [75,7]	2.08 [52,8]	1.34 [34,0]	1.00 [25,4]	2.10 [53,3]	1.26 [32,0]	.13 [3,3]	180	90	.077 [34,93]
222A185	2.66 [67,6]	2.30 [58,4]	1.74 [44,2]	2.66 [67,6]	2.30 [58,4]	2.14 [54,4]	.80 [20,3]	3.84 [97,5]	2.60 [66,0]	1.66 [42,2]	1.00 [25,4]	2.80 [71,1]	1.60 [40,6]	.15 [3,8]	180	90	.143 [64,86]
222A196	3.45 [87,6]	2.71 [68,8]	2.18 [55,4]	3.45 [87,6]	2.71 [68,8]	2.48 [63,0]	.92 [23,4]	5.04 [128,0]	3.12 [79,2]	1.93 [49,0]	1.00 [25,4]	3.45 [87,6]	2.22 [56,4]	.18 [4,6]	180	90	.310 [140,6]

CUSTOMER DRAWING

UNLESS OTHERWISE SPECIFIED DIMENSIONS ARE INCHES. METRIC DIMENSIONS ARE IN BRACKETS. DECIMAL TOLERANCES .XXX ± 0.005 [0.13 mm] .XX ± 0.01 [0.25 mm] .X ± 0.1 [0.50 mm] ANGLE TOLERANCE .X ± 1 DEG. TE CONNECTIVITY RESERVES THE RIGHT TO AMEND THIS DRAWING AT ANY TIME. USERS SHOULD EVALUATE THE SUITABILITY OF THE PRODUCT FOR THEIR APPLICATION. © 2004, 2011 Tyco Electronics Corporation, a TE Connectivity Ltd. company. All rights reserved.	DRAWN YUNGUYEN	TE Connectivity Raychem Molded Parts 305 Constitution Dr Menlo Park, CA 94025	
	APPROVED DHURRELL		TITLE BOOT, 90 DEGREE, THIN WALL
	THIRD ANGLE PROJECTION	SIZE B	CODE IDENT. NO. 06090



Компания «ЭлектроПласт» предлагает заключение долгосрочных отношений при поставках импортных электронных компонентов на взаимовыгодных условиях!

Наши преимущества:

- Оперативные поставки широкого спектра электронных компонентов отечественного и импортного производства напрямую от производителей и с крупнейших мировых складов;
- Поставка более 17-ти миллионов наименований электронных компонентов;
- Поставка сложных, дефицитных, либо снятых с производства позиций;
- Оперативные сроки поставки под заказ (от 5 рабочих дней);
- Экспресс доставка в любую точку России;
- Техническая поддержка проекта, помощь в подборе аналогов, поставка прототипов;
- Система менеджмента качества сертифицирована по Международному стандарту ISO 9001;
- Лицензия ФСБ на осуществление работ с использованием сведений, составляющих государственную тайну;
- Поставка специализированных компонентов (Xilinx, Altera, Analog Devices, Intersil, Interpoint, Microsemi, Aeroflex, Peregrine, Syfer, Eurofarad, Texas Instrument, Miteq, Cobham, E2V, MA-COM, Hittite, Mini-Circuits, General Dynamics и др.);

Помимо этого, одним из направлений компании «ЭлектроПласт» является направление «Источники питания». Мы предлагаем Вам помощь Конструкторского отдела:

- Подбор оптимального решения, техническое обоснование при выборе компонента;
- Подбор аналогов;
- Консультации по применению компонента;
- Поставка образцов и прототипов;
- Техническая поддержка проекта;
- Защита от снятия компонента с производства.



#### Как с нами связаться

**Телефон:** 8 (812) 309 58 32 (многоканальный)

**Факс:** 8 (812) 320-02-42

**Электронная почта:** [org@eplast1.ru](mailto:org@eplast1.ru)

**Адрес:** 198099, г. Санкт-Петербург, ул. Калинина, дом 2, корпус 4, литера А.