

# UM10895

QN9020 mini DK user guide

Rev. 2 — 24 May 2016

User manual

## Document information

Info	Content
<b>Keywords</b>	mini DK, J-Link OB, UART, SWD, GPIO, LED, button, power supply, buzzer
<b>Abstract</b>	This user manual describes the features of the QN9020_MINIDK_Vx board.



## Revision history

Rev	Date	Description
v.2	20160524	second release. Modifications: <ul style="list-style-type: none"><li>• <a href="#">Section 1.2 "Additional resource"</a> updated.</li><li>• <a href="#">Figure 5</a> updated.</li><li>• <a href="#">Section 2.6 "GPIO interface"</a> updated.</li><li>• <a href="#">Section 3.1 "Schematics for QN9020 mini DK board"</a> updated.</li></ul>
v.1	20150601	initial release

## Contact information

For more information, please visit: <http://www.nxp.com>

For sales office addresses, please send an email to: [salesaddresses@nxp.com](mailto:salesaddresses@nxp.com)

## 1. Introduction

---

This user manual describes the hardware details of the QN9020 mini Development Kit (DK).

### 1.1 Kit contents

The QN9020 mini development kit includes the following:

- QN9020 mini development board
- QN9020 USB dongle
- USB cable

### 1.2 Additional resource

For additional resources, visit

<http://www.nxp.com/products/microcontrollers-and-processors/more-processors/applications-specific-mcus-mpus/bluetooth-low-energy-ble:BLUETOOTH-LOW-ENERGY-BLE>

## 2. Hardware description

---

The QN9020 mini development board provides easy access to peripherals such as buttons, piezo buzzer and LED. The board also provides useful interfaces such as a USB port for UART communication and J-Link debug, and a GPIO/optional sensor board connector.

A USB dongle is a Bluetooth device powered by the QN9020. It acts as a master when communicating with the QN9020.

### 2.1 Hardware overview

The hardware blocks in the QN9020 mini DK, and the functional relationship of each main component, are shown in [Figure 1](#).

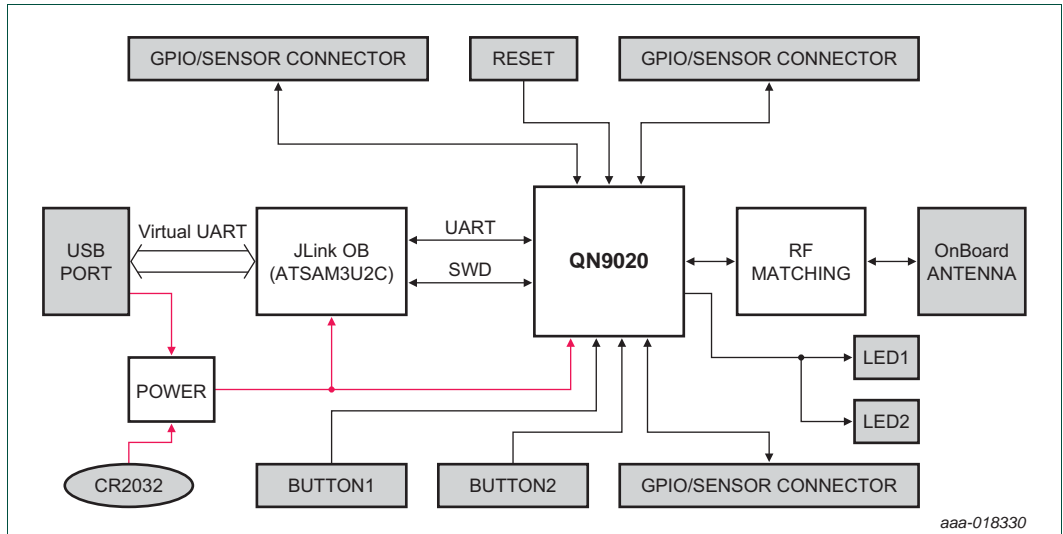

Fig 1. The QN9020 functional diagram

The component layout on both the sides of the board is shown in [Figure 2](#) and [Figure 3](#). The detailed information of each component is listed in [Table 1](#).

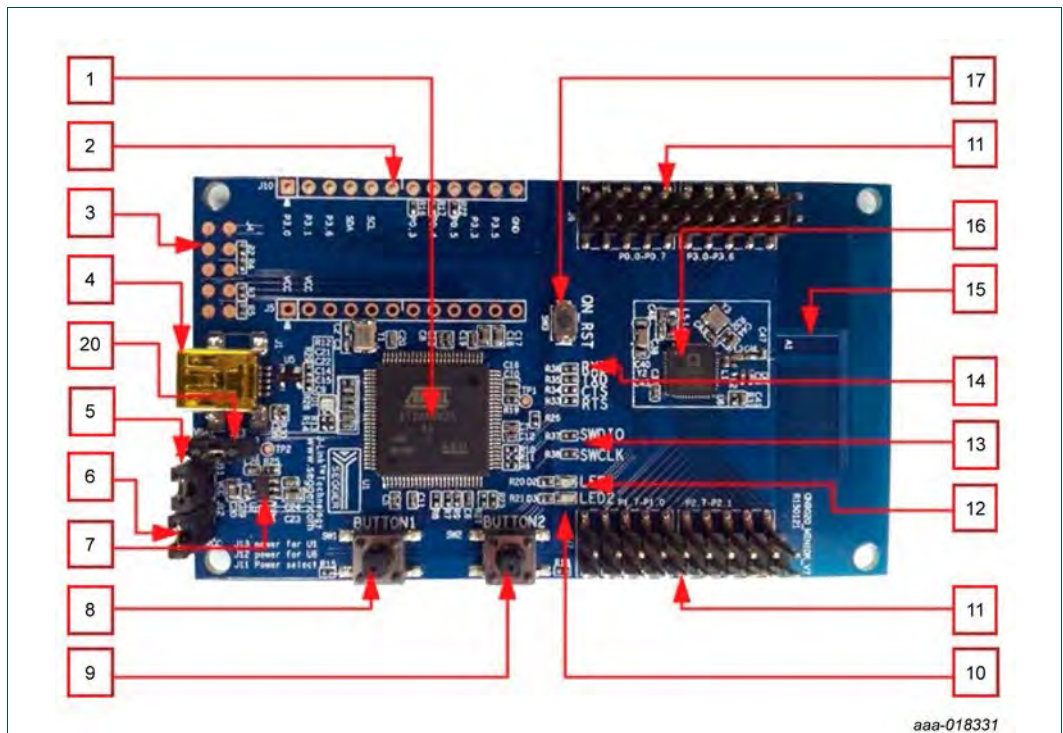

Fig 2. The QN9020 board top view

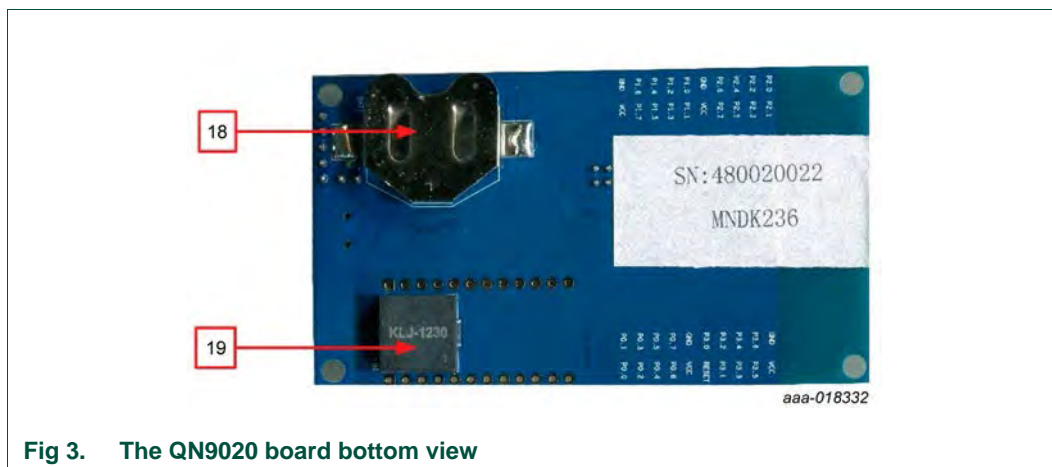

Fig 3. The QN9020 board bottom view

Table 1. QN9020 board components list

Number	Name	Description
1	J-Link OB	ATSAM3U2C; used to offer SWD and UART interfaces for QN9020 debug and communication
2	connector	optional; used for connecting sensor board
3	debug port	debug port for ATSAM3U2CA
4	mini USB port	power and communication port
5	power source select jumper	used for power source selection; see <a href="#">Section 2.3</a>
6	current measurement jumper	used to measure the QN9020 device power consumption
7	LDO (TPS73630)	5 V to 3 V regulator
8	button1	used as input; see <a href="#">Section 2.9</a>
9	button2	used as input; see <a href="#">Section 2.9</a>
10	LED2	used as output; see <a href="#">Section 2.8</a>
11	QN9020 GPIO port	used for interface extension
12	LED1	used as output; see <a href="#">Section 2.8</a>
13	SWD resistors	zero ohm resistors; shorted for QN9020 device debug
14	UART interface	used as communication port for QN9020 device
15	PCB antenna	onboard Bluetooth antenna
16	QN9020 chip	QN9020 chip
17	QN9020 reset button	used for QN9020 hardware reset
18	CR2032 battery holder	CR2032 battery holder
19	piezo buzzer	buzzer: KLJ-1230
20	jumper	used for power cycle ATSAM3U2CA

### 2.2 Default jumper settings on mini DK board

The jumpers on QN9020 mini DK are factory set to power the board over the USB. The factory-set jumper and switch settings are shown in [Table 2](#).

**Table 2. QN9020 mini DK board components list**

Jumper	Pins to be shorted using jumpers	Function
J11	2 and 3	USB powered
J12	1 and 2	VCC_QN9020 3.3 V
J13	1 and 2	VCC_MB 3.3 V

### 2.3 Power supply

The QN9020 board has two power supply modes:

1. Bus-power mode: The board can be powered using the USB cable. The onboard LDO is used to regulate output voltage to 3 V and supplies power to all parts on the board.
2. Battery-power mode: The CR2032 supplies power to QN9020 and optional sensor connector when it is in battery-power mode. The J-Link OB still uses the LDO as power supply via USB cable. When using USB interface as a power supply, connect the jumper J11 pin 2 and pin 3; see [Figure 4](#).

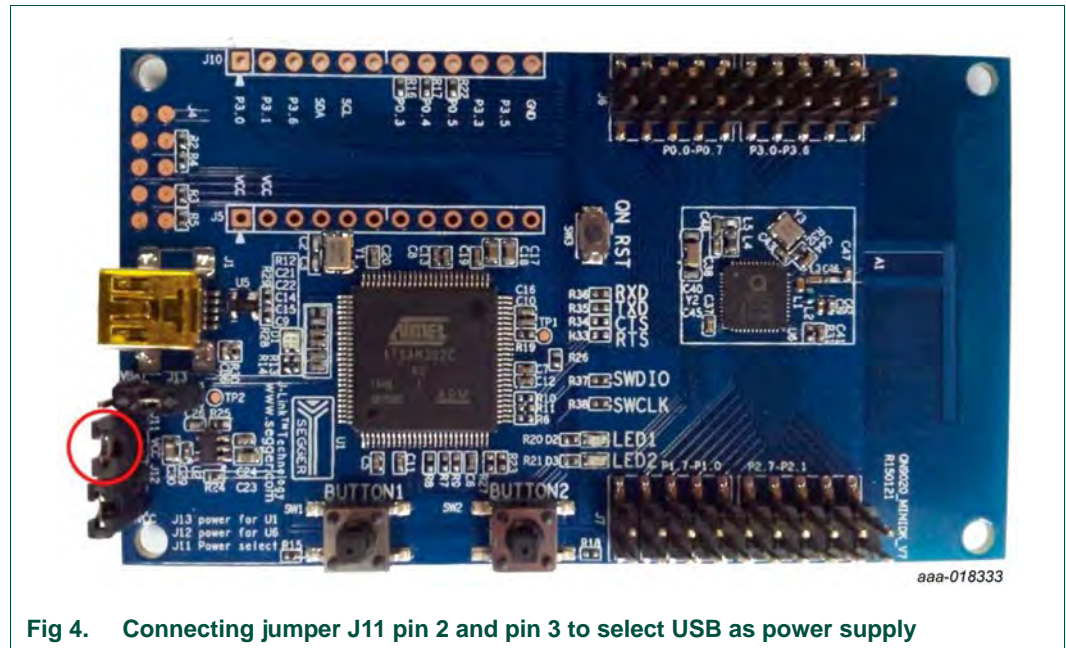

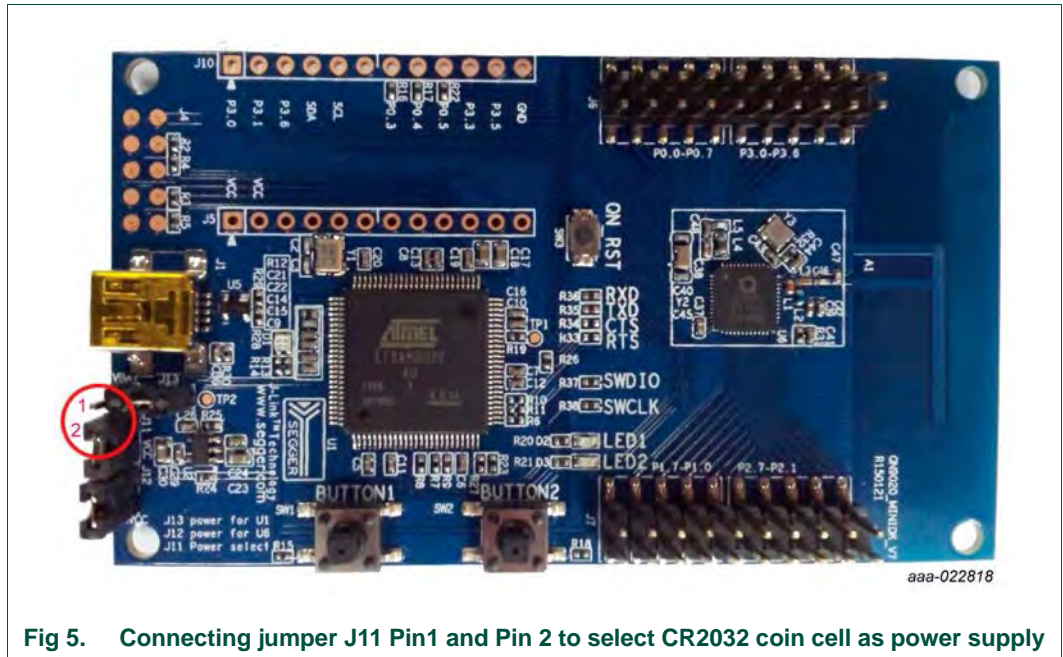

Fig 5. Connecting jumper J11 Pin1 and Pin 2 to select CR2032 coin cell as power supply

### 2.4 SEGGER J-Link OB part

The SEGGER J-Link OB offers the SWD and UART interface. Users can download or update firmware into a QN9020 device by using the UART or SWD interface. Furthermore, it is convenient to debug the program for a QN9020 device using SWD interface.

To program or debug the QN9020 device using the SEGGER J-Link OB, the 0 Ω resistors R37, R38 should be soldered; see [Figure 6](#).

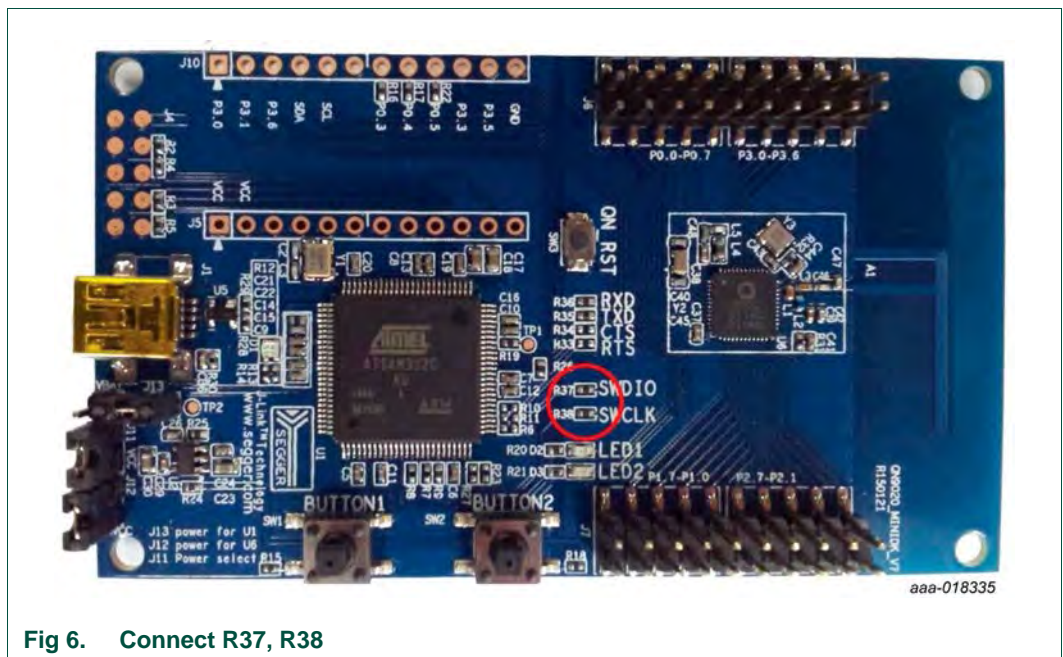
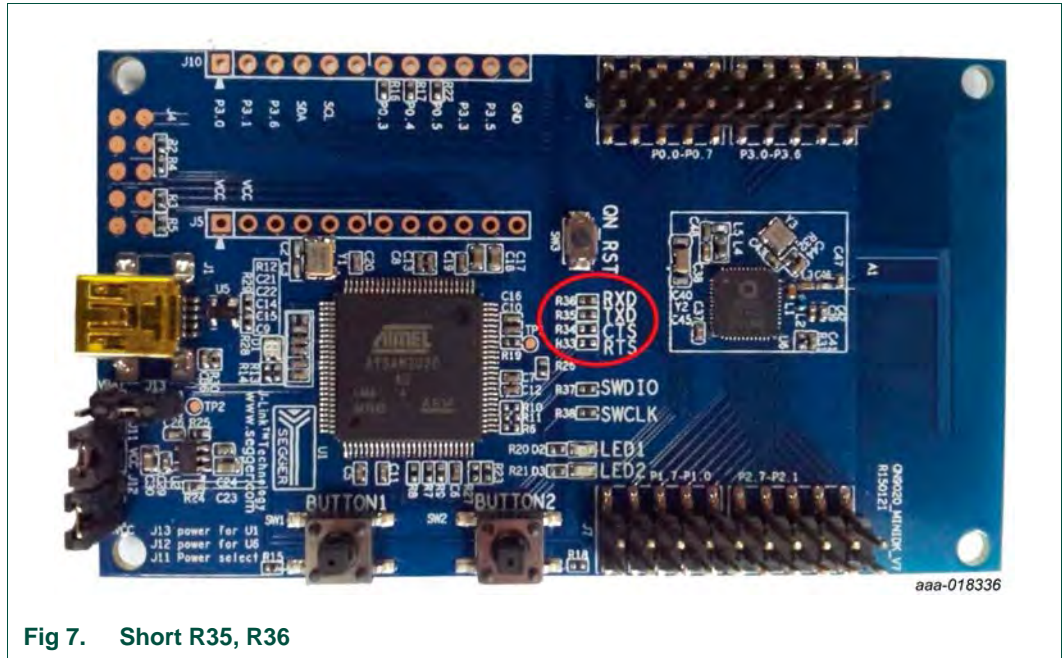

Fig 6. Connect R37, R38

In order to use a USB to UART bridge for the QN9020 download, the solder bridge SB3, SB4 should be shorted; see [Figure 7](#).



### 2.5 QN9020 device

The QN9020 device is integrated with a BLE radio, controller, protocol stack and profile software, and a high performance MCU on a single chip; see [Figure 8](#).

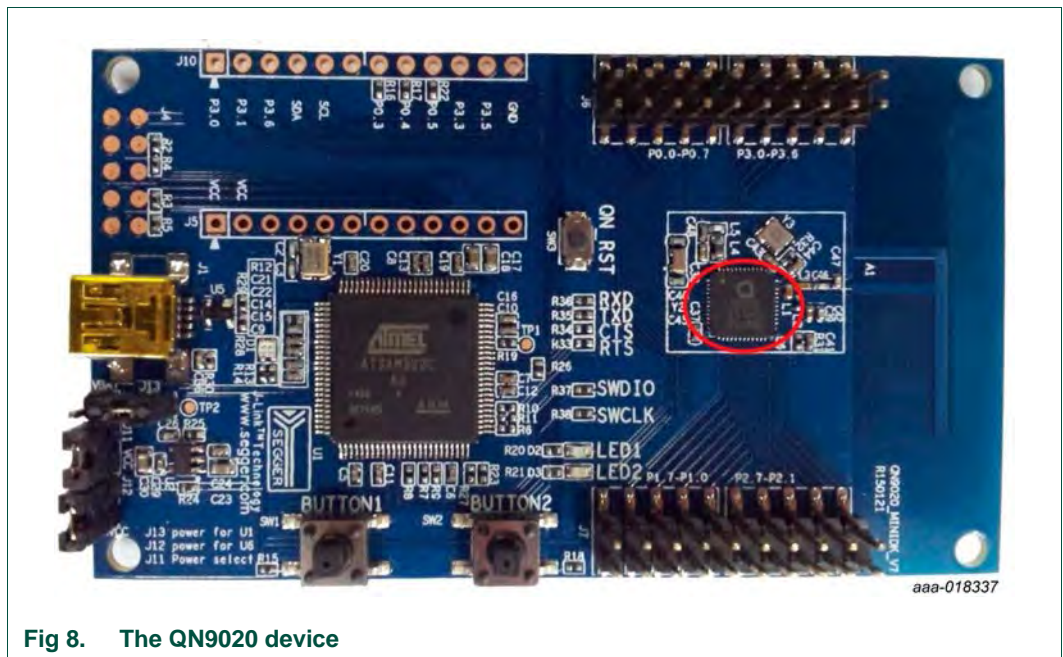



### 2.6 GPIO interface

In QN9020 mini development board version V7, the connectors J6, J7, J8 and J9 provide GPIO connection. The net name is shown in [Figure 9](#).

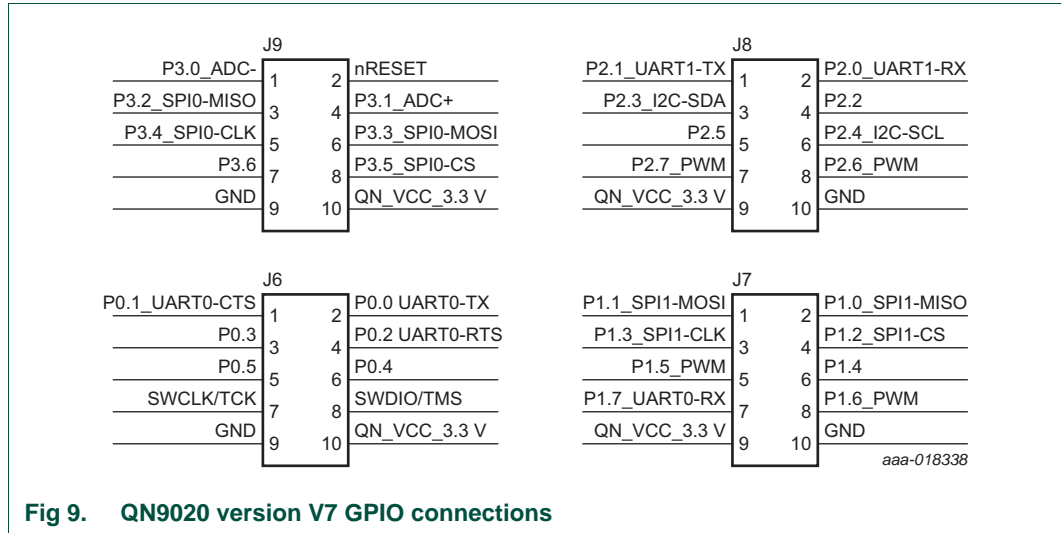

Fig 9. QN9020 version V7 GPIO connections

In QN9020 mini development board version V8, connectors J6 and J7 provide GPIO connection, as shown in [Figure 10](#).

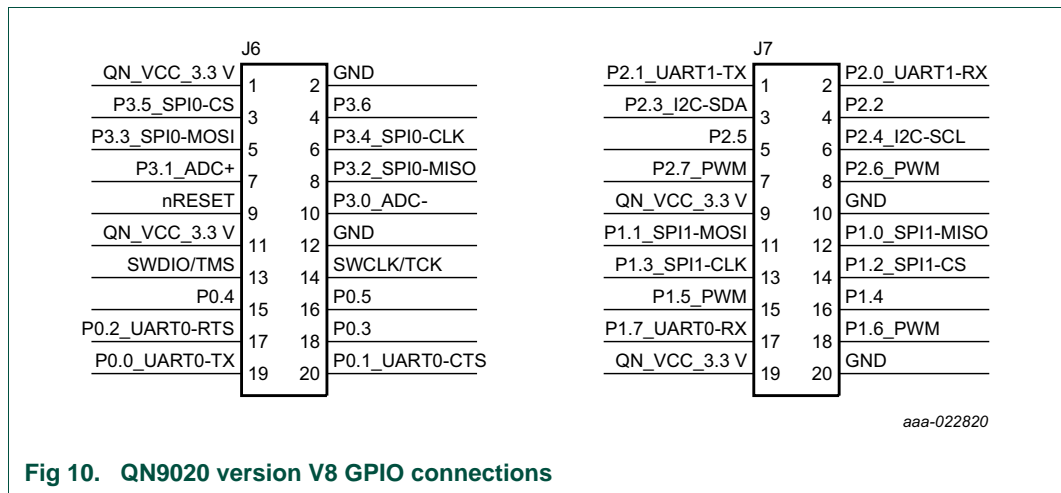

Fig 10. QN9020 version V8 GPIO connections

### 2.7 QN9020 reset button

The reset button is used to provide hardware reset to the QN9020 device. When programming the QN9020 using UART interface of SEGGER J-Link OB, the reset button should be pressed first to ensure that QN9020 is in boot mode. See [Figure 11](#) for the detailed circuit.

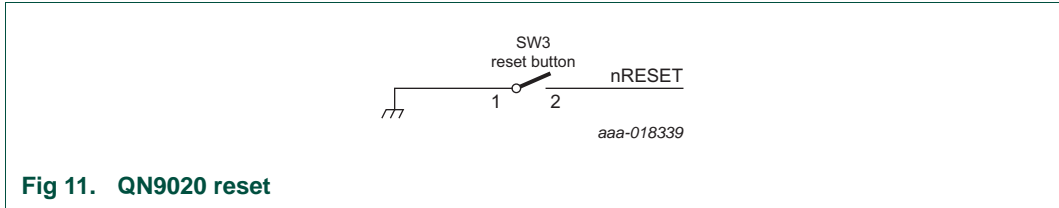

Fig 11. QN9020 reset

## 2.8 LED

The QN9020 board offers two programmable LEDs, which are connected to the QN9020 device GPIO.

LED1 and LED2 are connected to GPIO P0.4 and P0.5 respectively. The connections are shown in [Figure 12](#). The LEDs are powered-up when the corresponding GPIO outputs switch to logic LOW level.

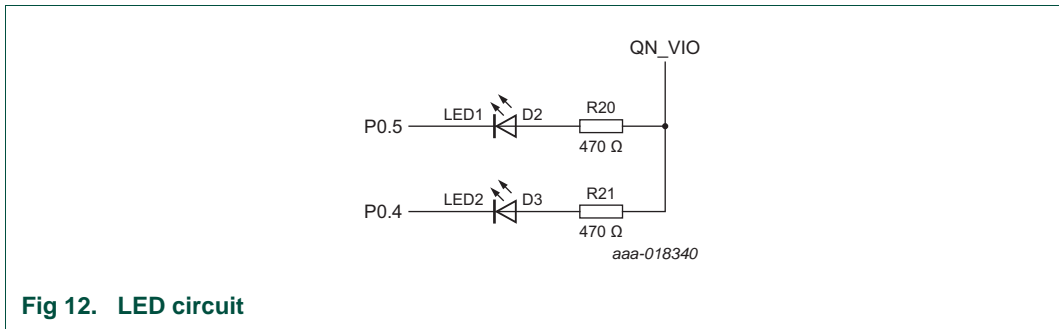

Fig 12. LED circuit

## 2.9 Button

The QN9020 board offers two buttons which are connected to QN9020 device GPIO. Button 1 and button 2 are connected to GPIO P1.4 and P1.5 respectively. See [Figure 13](#) for detailed circuits.

When using the buttons, the GPIO P1.4 and P1.5 must be configured as inputs. Logic LOW input is applied to QN9020 when a button is pressed.

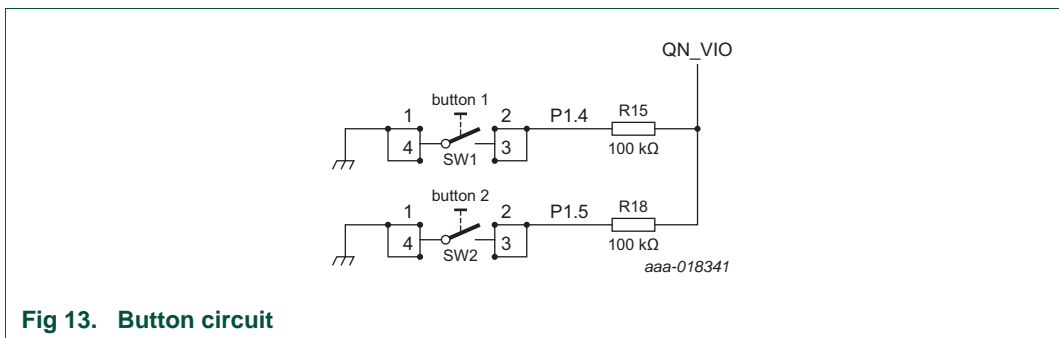

Fig 13. Button circuit

### 2.10 Piezo buzzer

The piezo buzzer receives input from GPIO P2.6; see [Figure 14](#). Refer to *KLJ-1230 data sheet* for detailed information.

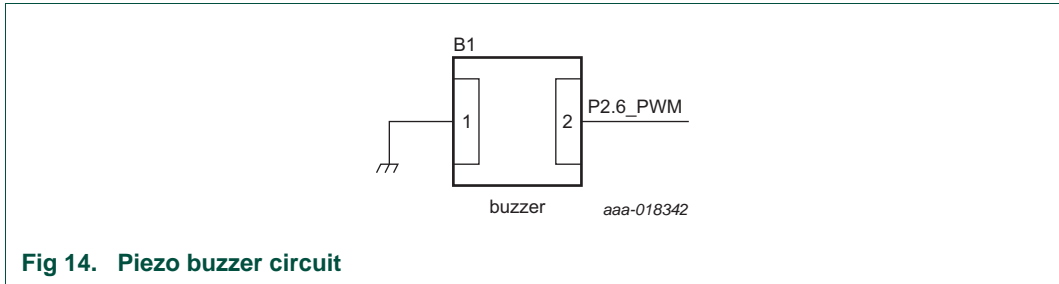

Fig 14. Piezo buzzer circuit

### 2.11 Optional sensor connector

These connectors are used as an interface to connect the sensor board. The pin name definitions are shown in [Figure 15](#).

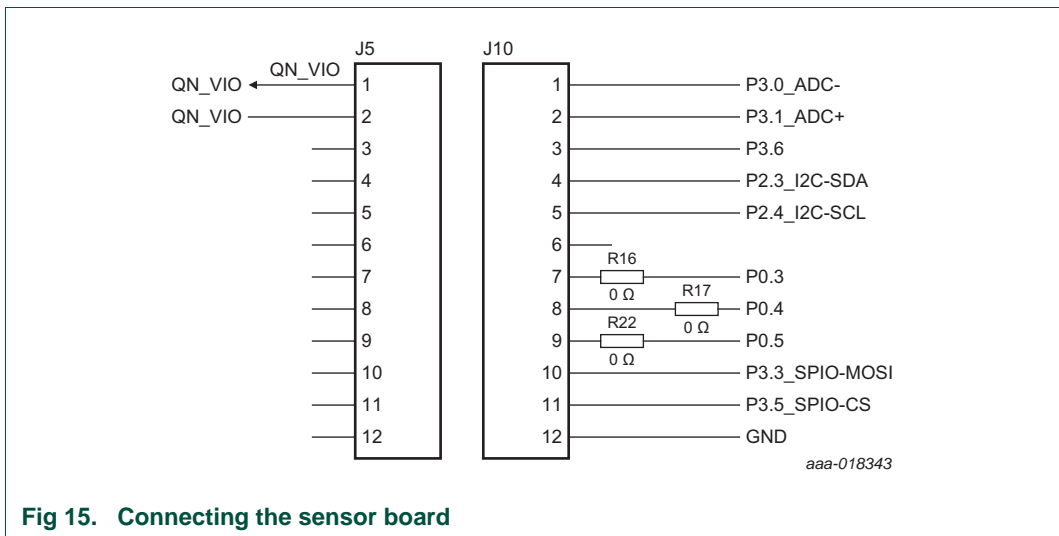

Fig 15. Connecting the sensor board

### 2.12 Current measurement

The jumper J12 is used to measure the QN9020 device current. In current test mode, the digital ammeter should be connected in series with J12. In the other modes, pin 1 and pin 2 of J12 are shorted. A jumper cap is used to short the pins.

### 3. Appendix - Schematics and PCB layout

#### 3.1 Schematics for QN9020 mini DK board

QN9020 mini DK board schematics have three parts: J-Link, power and QN9020.

Figure 16, Figure 17 and Figure 18 are the same for all versions. The QN9020 schematic in version V7 is shown in Figure 19. In version V8, it is shown in Figure 20.

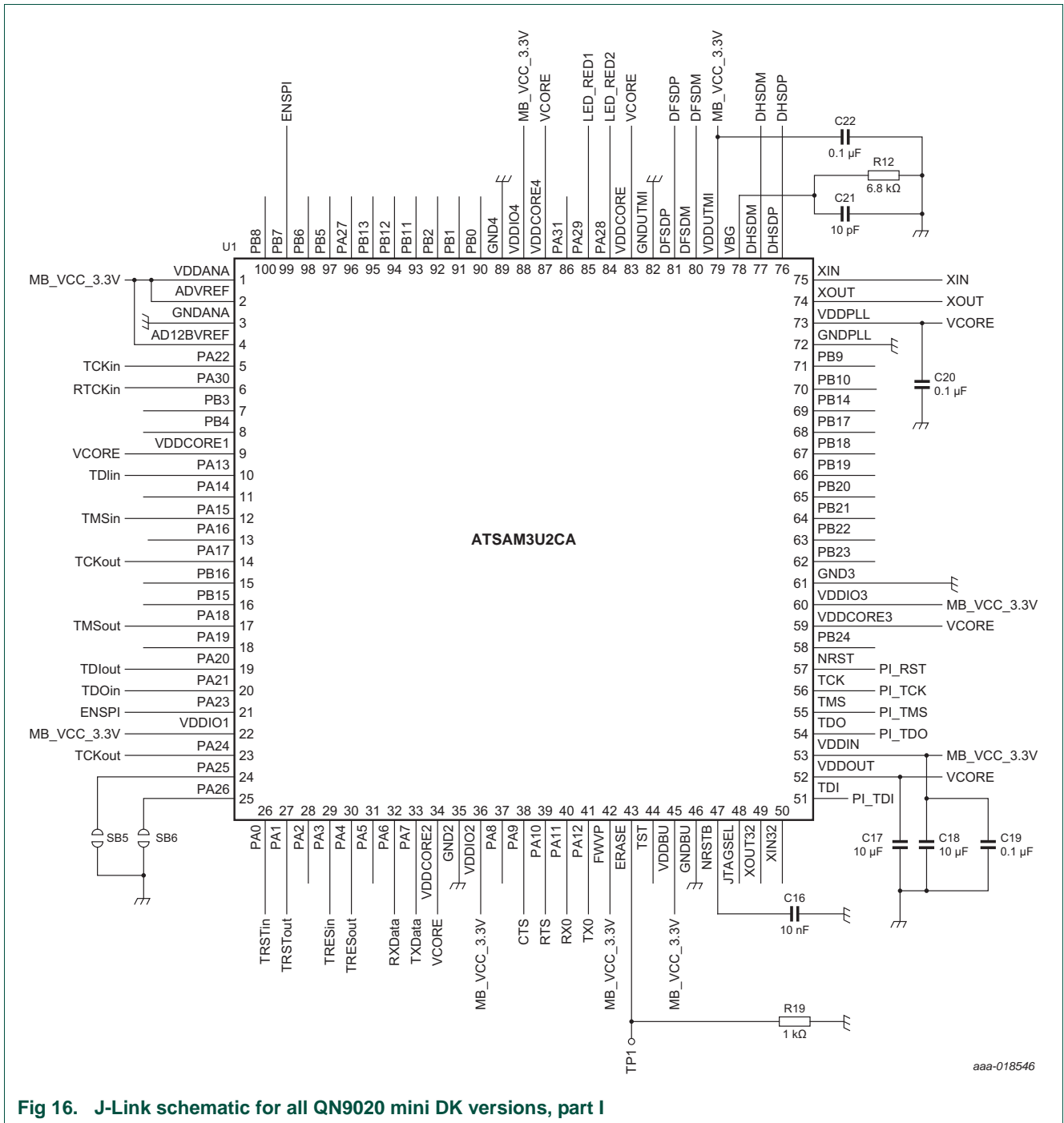
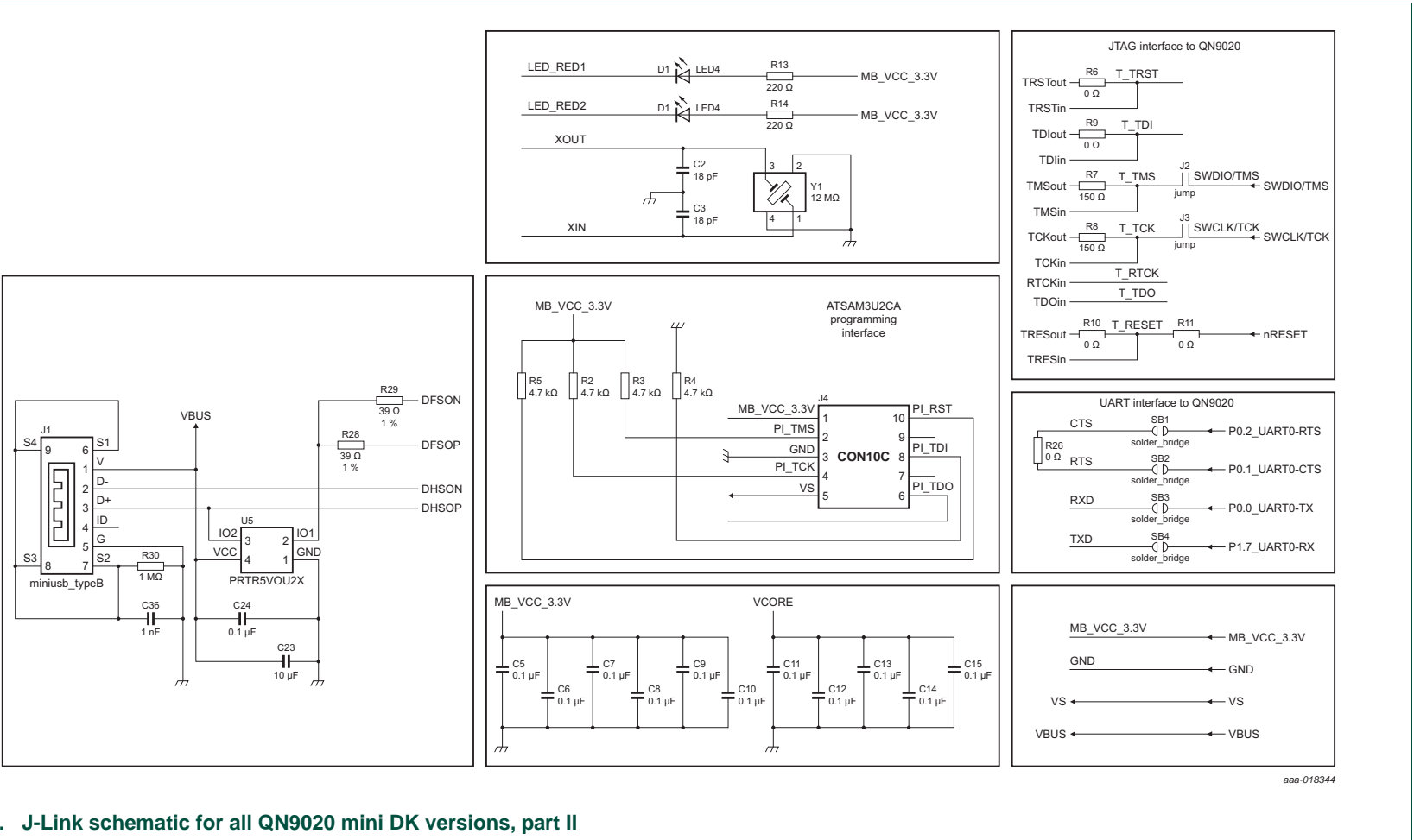

Fig 16. J-Link schematic for all QN9020 mini DK versions, part I



aaa-018344

Fig 17. J-Link schematic for all QN9020 mini DK versions, part II

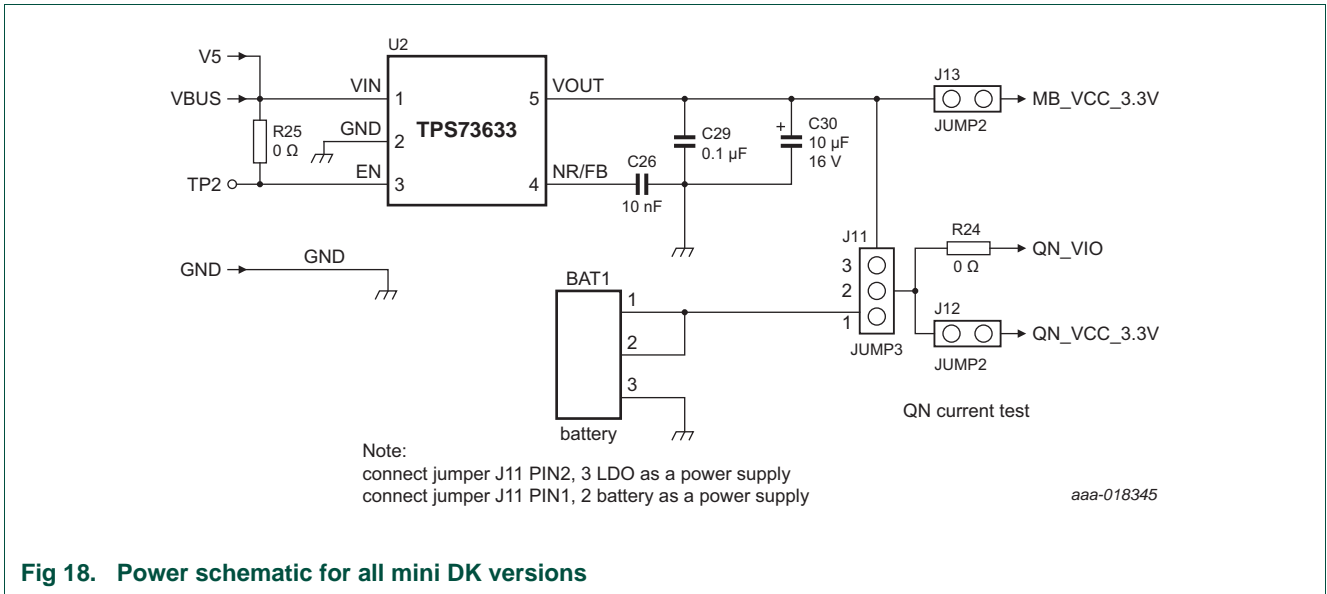
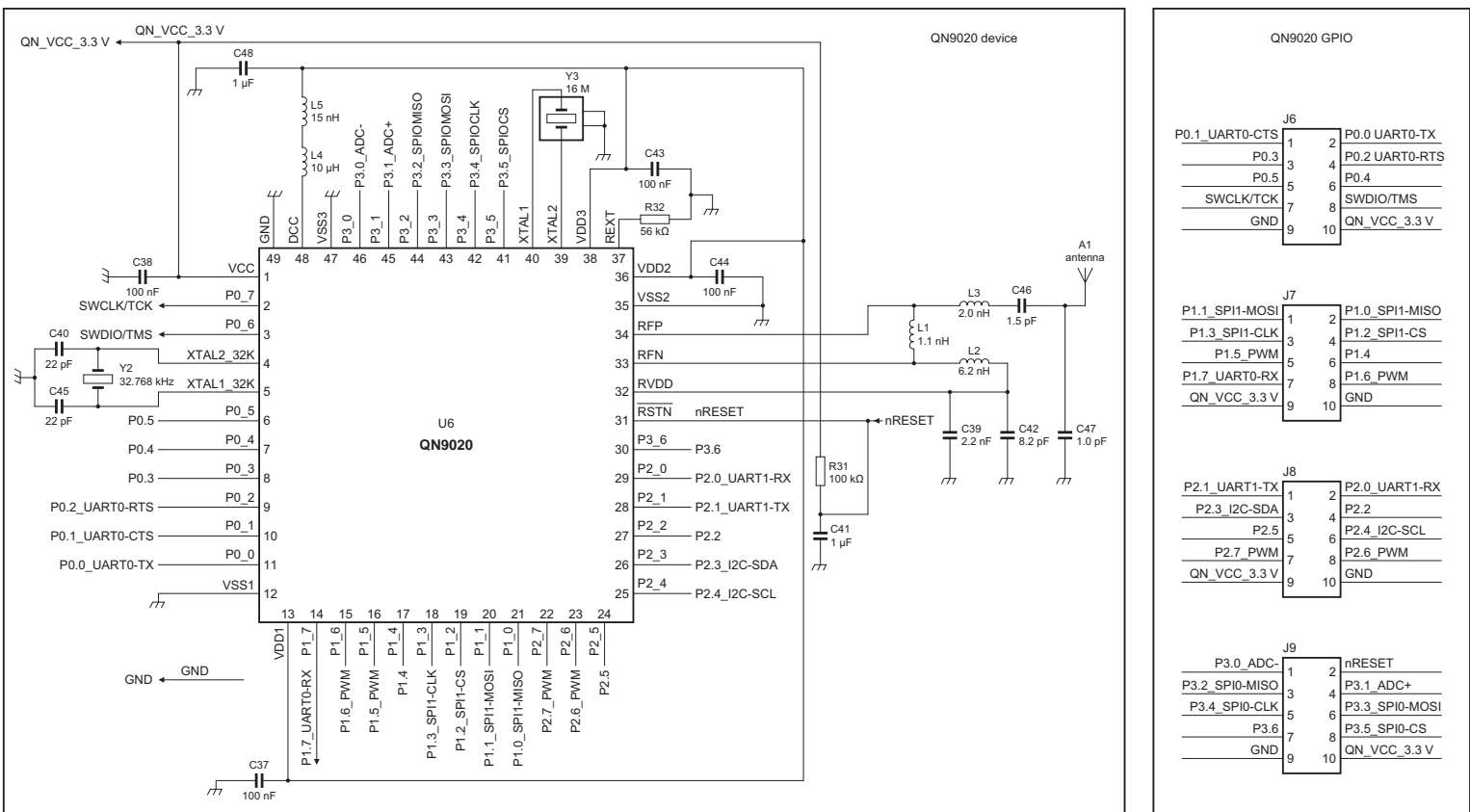

Fig 18. Power schematic for all mini DK versions



aaa-018346

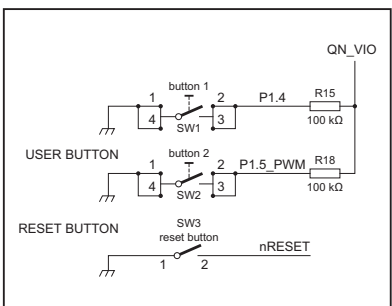
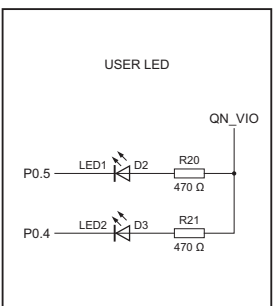
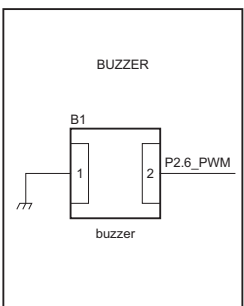
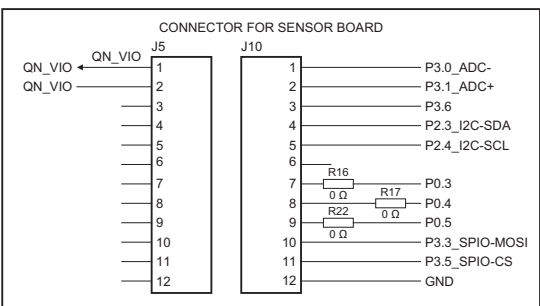
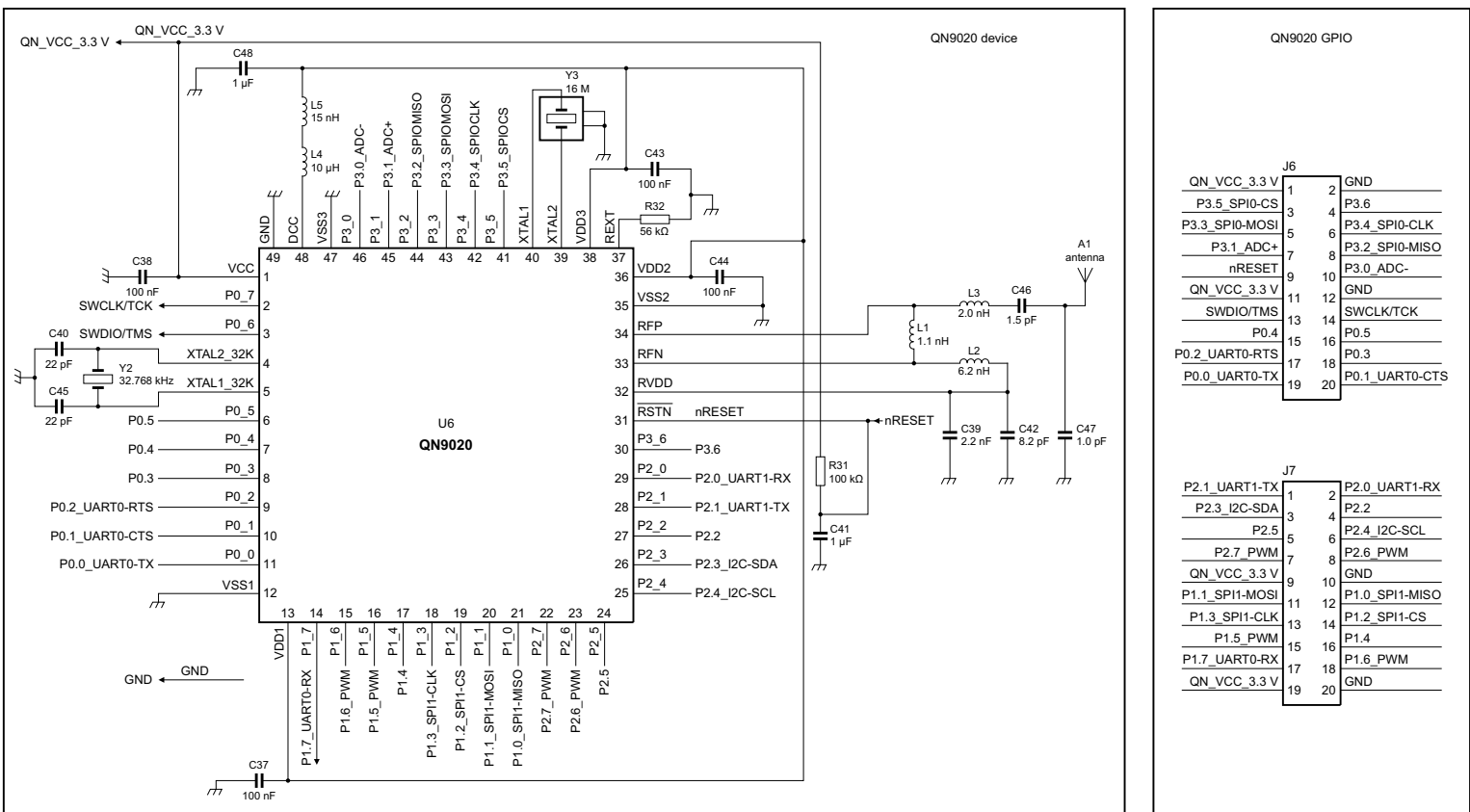

Fig 19. QN9020 schematic in QN9020 mini DK board V7 and below



QN9020 GPIO

J6			
QN_VCC_3.3 V	1	2	GND
P3.5_SPIO-CS	3	4	P3.6
P3.3_SPIO-MOSI	5	6	P3.4_SPIO-CLK
P3.1_ADC+	7	8	P3.2_SPIO-MISO
nRESET	9	10	P3.0_ADC-
QN_VCC_3.3 V	11	12	GND
SWDIO/TMS	13	14	SWCLK/TCK
P0.4	15	16	P0.5
P0.2_UART0-RTS	17	18	P0.3
P0.0_UART0-TX	19	20	P0.1_UART0-CTS

J7			
P2.1_UART1-TX	1	2	P2.0_UART1-RX
P2.3_I2C-SDA	3	4	P2.2
P2.5	5	6	P2.4_I2C-SCL
P2.7_PWM	7	8	P2.6_PWM
QN_VCC_3.3 V	9	10	GND
P1.1_SPH-MOSI	11	12	P1.0_SPH-MISO
P1.3_SPH-CLK	13	14	P1.2_SPH-CS
P1.5_PWM	15	16	P1.4
P1.7_UART0-RX	17	18	P1.6_PWM
QN_VCC_3.3 V	19	20	GND

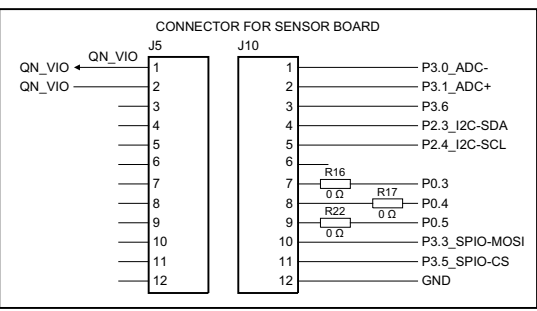
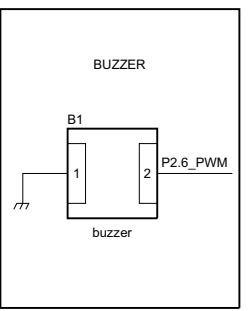
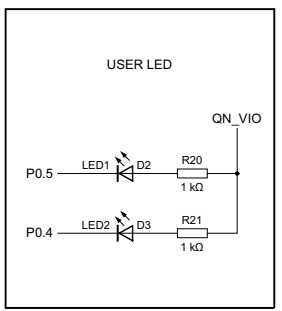
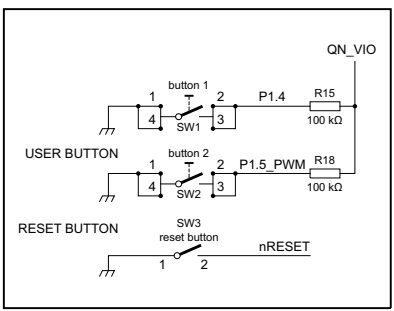

aaa-022819

Fig 20. QN9020 schematic in QN9020 mini DK board V8



3.2 PCB layout

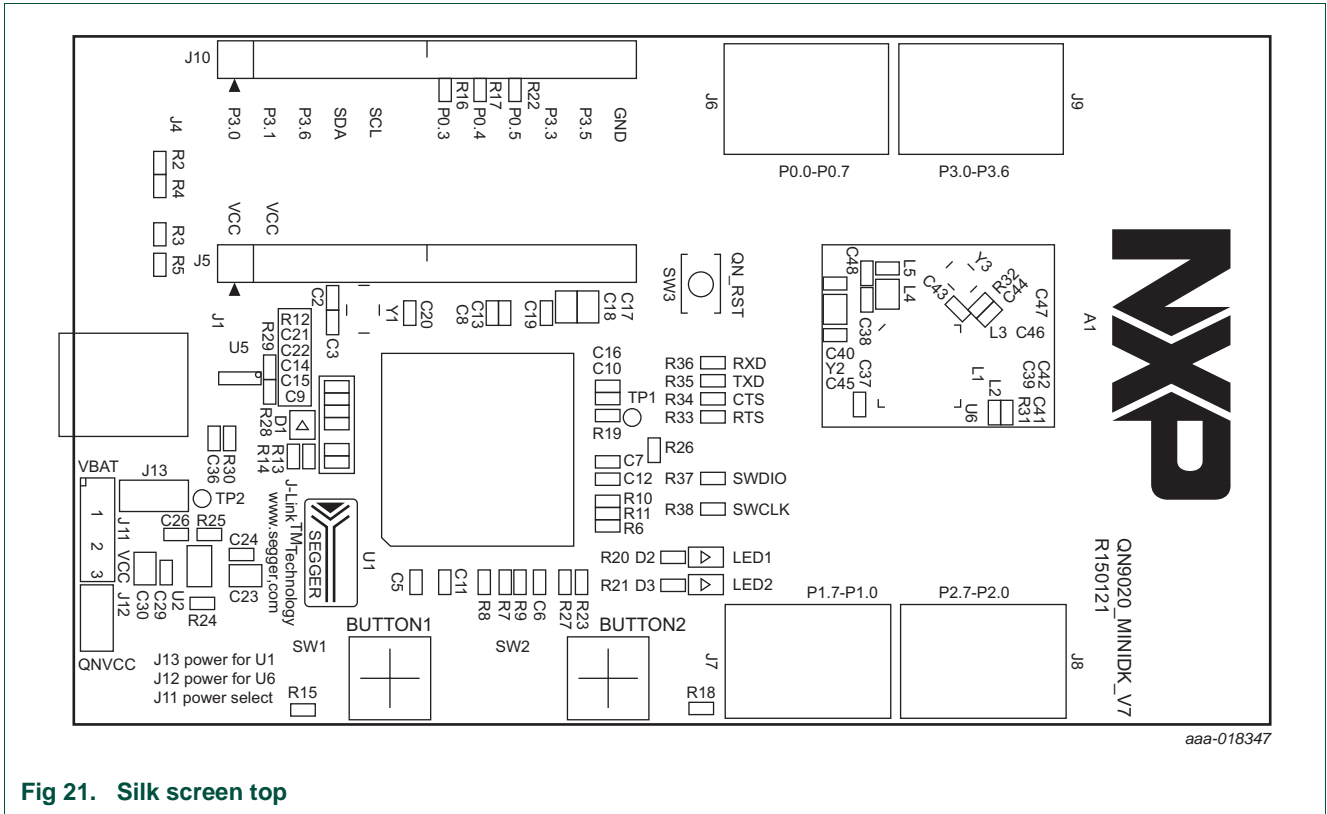
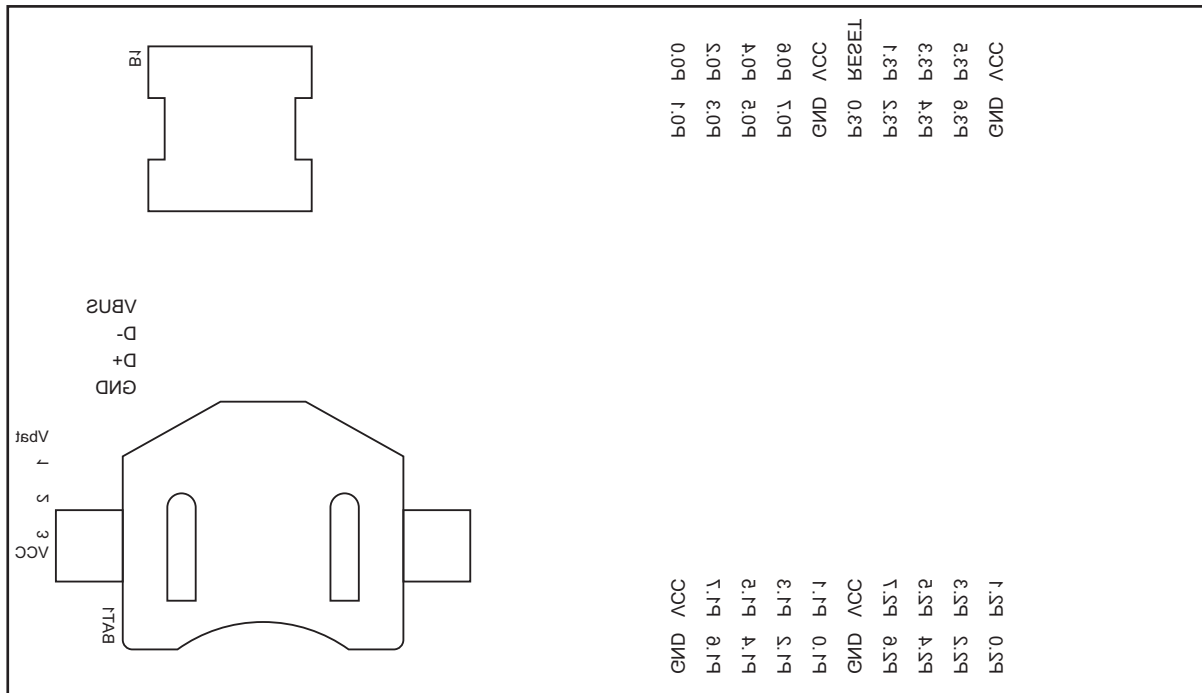

Fig 21. Silk screen top



aaa-018348

Fig 22. Silk screen bottom

## 4. Abbreviations

Table 3. Abbreviations

Acronym	Description
UART	Universal Asynchronous Receiver Transmitter
DK	Development Kit
LDO	Low DropOut
SWD	Serial Wire Debug
PCB	Printed-Circuit Board
BLE	Bluetooth Low Energy
MCU	MicroController Unit
GPIO	General Purpose Input Output
ISP	In System Programming
USB	Universal Serial Bus

## 5. Legal information

### 5.1 Definitions

**Draft** — The document is a draft version only. The content is still under internal review and subject to formal approval, which may result in modifications or additions. NXP Semiconductors does not give any representations or warranties as to the accuracy or completeness of information included herein and shall have no liability for the consequences of use of such information.

### 5.2 Disclaimers

**Limited warranty and liability** — Information in this document is believed to be accurate and reliable. However, NXP Semiconductors does not give any representations or warranties, expressed or implied, as to the accuracy or completeness of such information and shall have no liability for the consequences of use of such information. NXP Semiconductors takes no responsibility for the content in this document if provided by an information source outside of NXP Semiconductors.

In no event shall NXP Semiconductors be liable for any indirect, incidental, punitive, special or consequential damages (including - without limitation - lost profits, lost savings, business interruption, costs related to the removal or replacement of any products or rework charges) whether or not such damages are based on tort (including negligence), warranty, breach of contract or any other legal theory.

Notwithstanding any damages that customer might incur for any reason whatsoever, NXP Semiconductors' aggregate and cumulative liability towards customer for the products described herein shall be limited in accordance with the *Terms and conditions of commercial sale* of NXP Semiconductors.

**Right to make changes** — NXP Semiconductors reserves the right to make changes to information published in this document, including without limitation specifications and product descriptions, at any time and without notice. This document supersedes and replaces all information supplied prior to the publication hereof.

**Suitability for use** — NXP Semiconductors products are not designed, authorized or warranted to be suitable for use in life support, life-critical or safety-critical systems or equipment, nor in applications where failure or malfunction of an NXP Semiconductors product can reasonably be expected to result in personal injury, death or severe property or environmental damage. NXP Semiconductors and its suppliers accept no liability for inclusion and/or use of NXP Semiconductors products in such equipment or applications and therefore such inclusion and/or use is at the customer's own risk.

**Applications** — Applications that are described herein for any of these products are for illustrative purposes only. NXP Semiconductors makes no representation or warranty that such applications will be suitable for the specified use without further testing or modification.

Customers are responsible for the design and operation of their applications and products using NXP Semiconductors products, and NXP Semiconductors accepts no liability for any assistance with applications or customer product

design. It is customer's sole responsibility to determine whether the NXP Semiconductors product is suitable and fit for the customer's applications and products planned, as well as for the planned application and use of customer's third party customer(s). Customers should provide appropriate design and operating safeguards to minimize the risks associated with their applications and products.

NXP Semiconductors does not accept any liability related to any default, damage, costs or problem which is based on any weakness or default in the customer's applications or products, or the application or use by customer's third party customer(s). Customer is responsible for doing all necessary testing for the customer's applications and products using NXP Semiconductors products in order to avoid a default of the applications and the products or of the application or use by customer's third party customer(s). NXP does not accept any liability in this respect.

**Export control** — This document as well as the item(s) described herein may be subject to export control regulations. Export might require a prior authorization from competent authorities.

**Evaluation products** — This product is provided on an "as is" and "with all faults" basis for evaluation purposes only. NXP Semiconductors, its affiliates and their suppliers expressly disclaim all warranties, whether express, implied or statutory, including but not limited to the implied warranties of non-infringement, merchantability and fitness for a particular purpose. The entire risk as to the quality, or arising out of the use or performance, of this product remains with customer.

In no event shall NXP Semiconductors, its affiliates or their suppliers be liable to customer for any special, indirect, consequential, punitive or incidental damages (including without limitation damages for loss of business, business interruption, loss of use, loss of data or information, and the like) arising out of the use of or inability to use the product, whether or not based on tort (including negligence), strict liability, breach of contract, breach of warranty or any other theory, even if advised of the possibility of such damages.

Notwithstanding any damages that customer might incur for any reason whatsoever (including without limitation, all damages referenced above and all direct or general damages), the entire liability of NXP Semiconductors, its affiliates and their suppliers and customer's exclusive remedy for all of the foregoing shall be limited to actual damages incurred by customer based on reasonable reliance up to the greater of the amount actually paid by customer for the product or five dollars (US\$5.00). The foregoing limitations, exclusions and disclaimers shall apply to the maximum extent permitted by applicable law, even if any remedy fails of its essential purpose.

**Translations** — A non-English (translated) version of a document is for reference only. The English version shall prevail in case of any discrepancy between the translated and English versions.

### 5.3 Trademarks

Notice: All referenced brands, product names, service names and trademarks are the property of their respective owners.

## 6. Tables

Table 1. QN9020 board components list . . . . .	5	Table 3. Abbreviations . . . . .	18
Table 2. QN9020 mini DK board components list. . . . .	6		

## 7. Figures

Fig 1. The QN9020 functional diagram. . . . .	4
Fig 2. The QN9020 board top view. . . . .	4
Fig 3. The QN9020 board bottom view . . . . .	5
Fig 4. Connecting jumper J11 pin 2 and pin 3 to select USB as power supply . . . . .	6
Fig 5. Connecting jumper J11 Pin1 and Pin 2 to select CR2032 coin cell as power supply. . . . .	7
Fig 6. Connect R37, R38 . . . . .	7
Fig 7. Short R35, R36 . . . . .	8
Fig 8. The QN9020 device. . . . .	8
Fig 9. QN9020 version V7 GPIO connections . . . . .	9
Fig 10. QN9020 version V8 GPIO connections . . . . .	9
Fig 11. QN9020 reset . . . . .	10
Fig 12. LED circuit . . . . .	10
Fig 13. Button circuit . . . . .	10
Fig 14. Piezo buzzer circuit . . . . .	11
Fig 15. Connecting the sensor board. . . . .	11
Fig 16. J-Link schematic for all QN9020 mini DK versions, part I . . . . .	12
Fig 17. J-Link schematic for all QN9020 mini DK versions, part II . . . . .	13
Fig 18. Power schematic for all mini DK versions . . . . .	14
Fig 19. QN9020 schematic in QN9020 mini DK board V7 and below. . . . .	15
Fig 20. QN9020 schematic in QN9020 mini DK board V8 . . . . .	16
Fig 21. Silk screen top . . . . .	17
Fig 22. Silk screen bottom . . . . .	18

## 8. Contents

---

<b>1</b>	<b>Introduction</b> .....	<b>3</b>
1.1	Kit contents .....	3
1.2	Additional resource .....	3
<b>2</b>	<b>Hardware description</b> .....	<b>3</b>
2.1	Hardware overview .....	3
2.2	Default jumper settings on mini DK board .....	6
2.3	Power supply .....	6
2.4	SEGGER J-Link OB part .....	7
2.5	QN9020 device .....	8
2.6	GPIO interface .....	9
2.7	QN9020 reset button .....	9
2.8	LED .....	10
2.9	Button .....	10
2.10	Piezo buzzer .....	11
2.11	Optional sensor connector .....	11
2.12	Current measurement .....	11
<b>3</b>	<b>Appendix - Schematics and PCB layout</b> .....	<b>12</b>
3.1	Schematics for QN9020 mini DK board .....	12
3.2	PCB layout .....	17
<b>4</b>	<b>Abbreviations</b> .....	<b>18</b>
<b>5</b>	<b>Legal information</b> .....	<b>19</b>
5.1	Definitions .....	19
5.2	Disclaimers .....	19
5.3	Trademarks .....	19
<b>6</b>	<b>Tables</b> .....	<b>20</b>
<b>7</b>	<b>Figures</b> .....	<b>20</b>
<b>8</b>	<b>Contents</b> .....	<b>21</b>

---

Please be aware that important notices concerning this document and the product(s) described herein, have been included in section 'Legal information'.

---

© NXP Semiconductors N.V. 2016.

All rights reserved.

For more information, please visit: <http://www.nxp.com>

For sales office addresses, please send an email to: [salesaddresses@nxp.com](mailto:salesaddresses@nxp.com)

Date of release: 24 May 2016

Document identifier: UM10895



Компания «ЭлектроПласт» предлагает заключение долгосрочных отношений при поставках импортных электронных компонентов на взаимовыгодных условиях!

Наши преимущества:

- Оперативные поставки широкого спектра электронных компонентов отечественного и импортного производства напрямую от производителей и с крупнейших мировых складов;
- Поставка более 17-ти миллионов наименований электронных компонентов;
- Поставка сложных, дефицитных, либо снятых с производства позиций;
- Оперативные сроки поставки под заказ (от 5 рабочих дней);
- Экспресс доставка в любую точку России;
- Техническая поддержка проекта, помощь в подборе аналогов, поставка прототипов;
- Система менеджмента качества сертифицирована по Международному стандарту ISO 9001;
- Лицензия ФСБ на осуществление работ с использованием сведений, составляющих государственную тайну;
- Поставка специализированных компонентов (Xilinx, Altera, Analog Devices, Intersil, Interpoint, Microsemi, Aeroflex, Peregrine, Syfer, Eurofarad, Texas Instrument, Miteq, Cobham, E2V, MA-COM, Hittite, Mini-Circuits, General Dynamics и др.);

Помимо этого, одним из направлений компании «ЭлектроПласт» является направление «Источники питания». Мы предлагаем Вам помощь Конструкторского отдела:

- Подбор оптимального решения, техническое обоснование при выборе компонента;
- Подбор аналогов;
- Консультации по применению компонента;
- Поставка образцов и прототипов;
- Техническая поддержка проекта;
- Защита от снятия компонента с производства.



#### Как с нами связаться

**Телефон:** 8 (812) 309 58 32 (многоканальный)

**Факс:** 8 (812) 320-02-42

**Электронная почта:** [org@eplast1.ru](mailto:org@eplast1.ru)

**Адрес:** 198099, г. Санкт-Петербург, ул. Калинина, дом 2, корпус 4, литера А.