

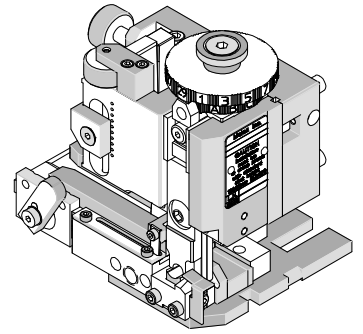

Mini-Mac Applicator Application Tooling Specification Mechanical Feed-Front Metal Strip Order No. 63895-0700



FEATURES

- Directly adapts to most automatic wire processing machines
- Applicator designed to industry standard mounting and shut height 135.80mm (5.346")
- Quick set-up time; plus the crimp height, track and feed adjustments can be set without removing the applicator from the press
- Fine adjustment allows users to achieve target with little effort by adjusting in increments of .015mm (.0006") for conductor crimp height and .063mm (.0025") for insulation height
- Independent adjustment rings allow users to quickly adjust the conductor or insulation crimp height without affecting each other.

SCOPE

Products: Quick Disconnect, Female, Flag, for 0.50-1.00mm² (18-20 AWG) Wire, Accepts 6.35mm (.250") by 0.81mm (.032") Tab Crimp Terminals.

Terminal Series No.	Terminal Order No.		Wire Size		Insulation Diameter				Strip Length	
					IPC/WHMA-A620 ♦		Terminal (Max) ♦♦			
					AWG	mm ²	mm	In.	mm	In.
94030	94030-5000	94030-5001	-	1.00	2.10-2.60	.083-.102	2.60	.102	6.00-7.00	.236-.276
			18	0.80						
			-	0.80						
			20	0.50						
			-	0.50						

♦ To achieve optimum IPC-A620 insulation crimps, use this insulation OD range.
♦♦ Overall insulation OD specification for terminal.

DEFINITION OF TERMS

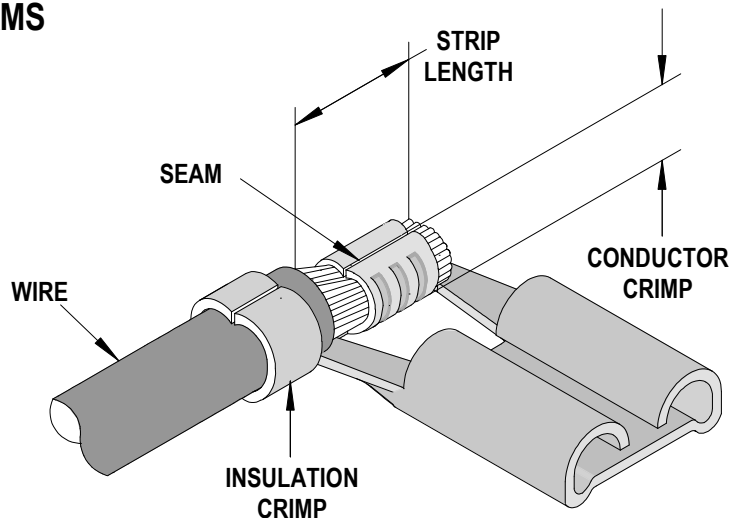

The above terminal drawing is a generic terminal representation. It is not an image of any terminal listed in the scope.

CRIMP SPECIFICATION

After crimping, the crimp profiles should measure the following:

Terminal Series No.	Wire Size		Conductor				Insulation				Pull Force Minimum	
			Crimp Height		Crimp Width Maximum		Crimp Height		Crimp Width Maximum			
	AWG	mm ²	mm	In.	mm	In.	mm	In.	mm	In.	N	Lb.
94030	-	1.00	1.60-1.70	.063-.067	2.35	.093	3.00-3.10	.118-.122	3.45	.136	156.9	35.27
	18	0.80	1.50-1.60	.059-.063	2.35	.093	2.90-3.00	.114-.118	3.45	.136	117.7	26.46
	-	0.80	1.50-1.60	.059-.063	2.35	.093	2.90-3.00	.114-.118	3.45	.136	117.7	26.46
	20	0.50	1.40-1.50	.055-.059	2.35	.093	2.80-2.90	.110-.114	3.45	.136	78.5	17.64
	-	0.50	1.40-1.50	.055-.059	2.35	.093	2.80-2.90	.110-.114	3.45	.136	78.5	17.64

* Tool Qualification Notes:

1. Pull Force should be measured with no influence from the insulation crimp.
2. The above specifications are guidelines to an optimum crimp.

PARTS LIST

Mini-Mac Applicator 63895-0700				
Item	Order No	Engineering No.	Description	Quantity
Perishable Tooling				
	63895-0770	63895-0770	Tool Kit (All "Y" Items)	REF
1	63475-0002	63475-0002	Conductor Punch-2.20pw	1 Y
2	63895-0702	63895-0702	Anvil	1 Y
3	63476-0002	63476-0002	Insulation Punch-3.20pw	1 Y
4	63445-3242	63445-3242	Insulation Anvil	1 Y
5	63895-0705	63895-0705	Cut Punch Left	1 Y
6	63895-0706	63895-0706	Cut Punch Right	1 Y
7	63895-0703	63895-0703	Cut-Off Die-Front	2 Y
8	63895-0735	63895-0735	Lifter	1 Y
9	63895-0734	63895-0734	Retainer Lifter	1 Y
Other Components (Ref. 50750)				
10	11-18-5015	60805A122	Front Cover	1
11	11-24-1067	4996-4	Cut Off Plunger Spring	1
12	63443-2310	63443-2310	3.50mm Spacer	1
13	63600-2995	63600-2995	Compression Spring	2
14	63890-0042	63890-0042	Terminal Drag Cover	1
15	63890-0046	63890-0046	Rear Cover	1
16	63890-0866	63890-0866	Collar-6.40 Long	1
17	63895-0731	63895-0731	Guide Cut Punch	1
18	63895-0732	63895-0732	Key 37	1
19	63895-0733	63895-0733	Key 16	1
20	63895-0736	63895-0736	Wire Stop	1
21	63895-0737	63895-0737	Punch Spacer 3.65	1
22	63895-0738	63895-0738	Tooling Washer	1
Frame				
23	63801-3201	63801-3201	Top	1
24	63801-3281	63801-3281	Base	1
25	63801-4650	63801-4650	Track	1
Hardware				
26	N/A	N/A	M2.5 by 20 Long SHCS	2**
27	N/A	N/A	M3 by 6 Long FHCS	2**
28	N/A	N/A	M3 by 6 Long SHCS	4**
29	N/A	N/A	M4 by 12 Long BHCS	2**
30	N/A	N/A	M4 by 50 Long SHCS	2**
31	N/A	N/A	M8 by 35 Long BHCS	1**
32	N/A	N/A	2.5mm by 8 Lg Roll Pin	3**
** Available from an industrial supply company such as MSC (1-800-645-7270).				

Assembly Drawing

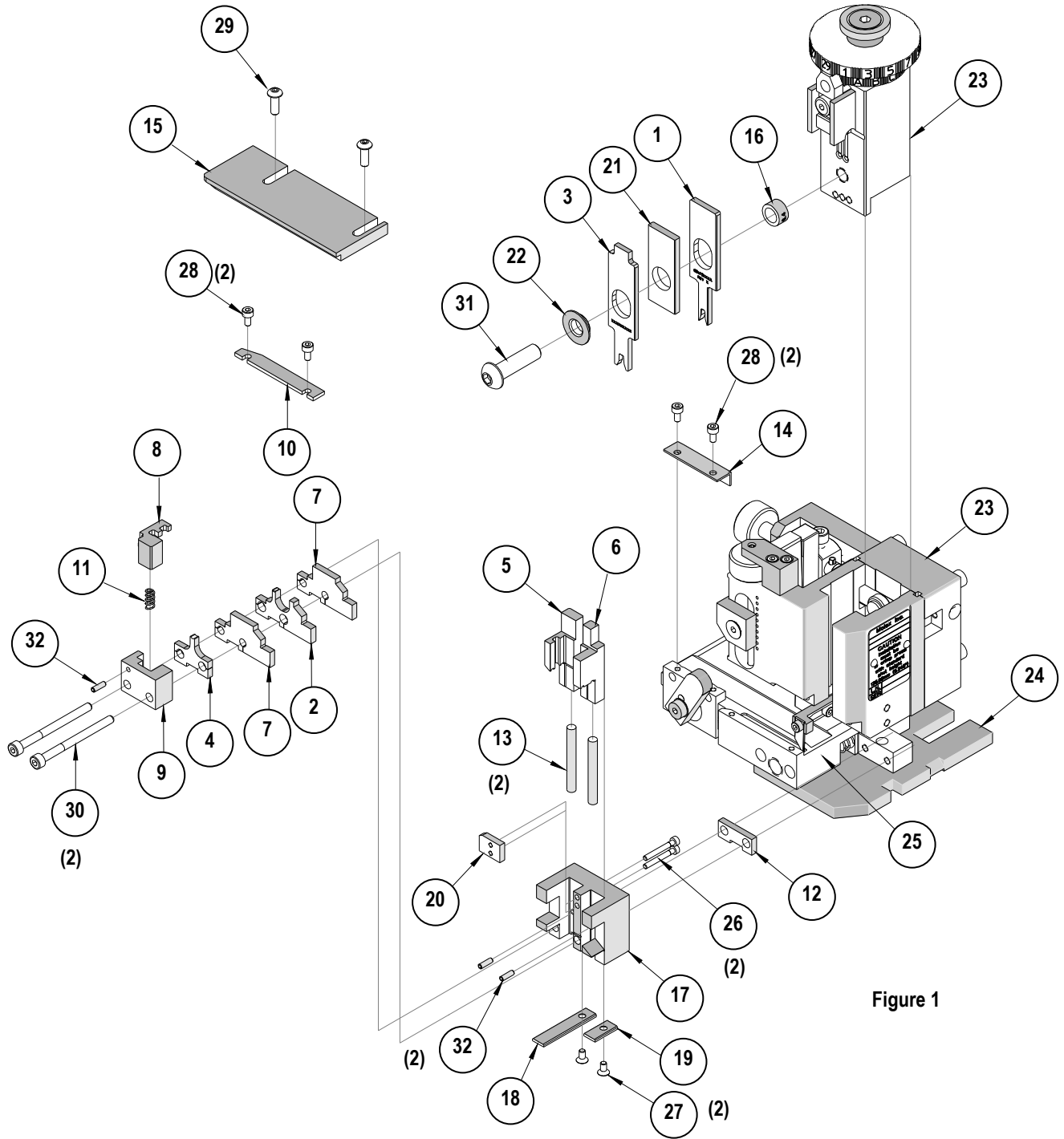

Figure 1

NOTES

1. Molex recommends an extra perishable tooling kit be maintained at your facility.
2. Verify tooling alignment by manually cycling the press with applicator before crimping under power. Check that all screws are tight.
3. Slugs, terminals, dirt, and oil should be kept clear of work area.
4. Wear safety glasses at all times.
5. For recommended maintenance refer to the Mini-Mac Applicator Manual (Document no. 63880-0000).

CAUTION: This applicator should only be used in a press with a shut height of 135.80 mm (5.346"). Tooling damage could result at a lower setting.

CAUTION: To prevent injury, never operate this applicator without the guards supplied with the press or wire-processing machine in place. Reference the press or wire processing manufacturer's instruction manual.

CAUTION: Molex crimp specifications are valid only when used with Molex terminals, applicators and tooling.

Contact Information

For more information on Molex application tooling please contact Molex at 1-800-786-6539.

Americas Headquarters
Lisle, Illinois 60532 U.S.A.
1-800-78MOLEX
amerinfo@molex.com

Far East North Headquarters
Yamato, Kanagawa, Japan
81-462-65-2324
feninfo@molex.com

Far East South Headquarters
Jurong, Singapore
65-6-268-6868
fesinfo@molex.com

European Headquarters
Munich, Germany
49-89-413092-0
eurinfo@molex.com

Corporate Headquarters
2222 Wellington Ct.
Lisle, IL 60532 U.S.A.
630-969-4550
Fax: 630-969-1352

Visit our Web site at <http://www.molex.com>



Компания «ЭлектроПласт» предлагает заключение долгосрочных отношений при поставках импортных электронных компонентов на взаимовыгодных условиях!

Наши преимущества:

- Оперативные поставки широкого спектра электронных компонентов отечественного и импортного производства напрямую от производителей и с крупнейших мировых складов;
- Поставка более 17-ти миллионов наименований электронных компонентов;
- Поставка сложных, дефицитных, либо снятых с производства позиций;
- Оперативные сроки поставки под заказ (от 5 рабочих дней);
- Экспресс доставка в любую точку России;
- Техническая поддержка проекта, помощь в подборе аналогов, поставка прототипов;
- Система менеджмента качества сертифицирована по Международному стандарту ISO 9001;
- Лицензия ФСБ на осуществление работ с использованием сведений, составляющих государственную тайну;
- Поставка специализированных компонентов (Xilinx, Altera, Analog Devices, Intersil, Interpoint, Microsemi, Aeroflex, Peregrine, Syfer, Eurofarad, Texas Instrument, Miteq, Cobham, E2V, MA-COM, Hittite, Mini-Circuits, General Dynamics и др.);

Помимо этого, одним из направлений компании «ЭлектроПласт» является направление «Источники питания». Мы предлагаем Вам помощь Конструкторского отдела:

- Подбор оптимального решения, техническое обоснование при выборе компонента;
- Подбор аналогов;
- Консультации по применению компонента;
- Поставка образцов и прототипов;
- Техническая поддержка проекта;
- Защита от снятия компонента с производства.



Как с нами связаться

Телефон: 8 (812) 309 58 32 (многоканальный)

Факс: 8 (812) 320-02-42

Электронная почта: org@eplast1.ru

Адрес: 198099, г. Санкт-Петербург, ул. Калинина, дом 2, корпус 4, литера А.