

EVAL-M3-CM615PN User Manual

iMOTION™ Modular Application Design Kit

About this document

Scope and purpose

This user manual provides an overview of the evaluation board Eval-M3-CM615PN including its main features, key data, pin assignments and mechanical dimensions.

Eval-M3-CM615PN is an evaluation board as part of the iMOTION™ Modular Application Design Kit. This power board includes a PFC integrated 3-phase CIPOS™ Mini Intelligent Power Module (IPM) for motor drive application. In combination with the control board equipped with the M3 30pin interface connector such as EVAL-M3-102T, it features and demonstrates Infineon's CIPOS™ Mini IPM technology and Advanced Motion Control Engine (MCE 2.0) technology for permanent magnet motors drive over the full speed range.

The inverter section has 600V of voltage and 15A of current rating, and the PFC section has 650V of voltage and 30A of current rating. It is optimized to major home appliances like air conditioners and low power motor drive application with high frequency switching operation of power factor correction.

This evaluation board Eval-M3-CM615PN was developed to support customers during their first steps designing applications with CIPOS™ Mini PFC integrated IPM IFCM15P60GD and running any permanent magnet motor via sensorless sinusoidal control.

Intended audience

This user manual is intended for all technical specialists who know motor control and high power electronics converter and this board is intended to be used under laboratory conditions.

Table of contents

About this document	1
Table of contents	1
1 Safety precautions	3
2 Introduction	4
3 EVAL-M3-CM615PN main features	6
3.1 EVAL-M3- CM615PN board specifications.....	7
3.2 Pin assignment.....	9
4 Getting Started with EVAL-M3-CM615PN	11
4.1 Setting up the system.....	11
4.2 iMOTION™ development tools and software	13
4.2.1 MCEWizard setup overview.....	13
4.2.2 MCEDesigner setup overview	15
5 Hardware description of EVAL-M3-CM615PN	17
5.1 Boost PFC section using CIPOS™ mini IPM.....	17
5.1.1 AC Voltage sensing and MCEWizard configuration	17
5.1.2 PFC External Current feedback configuration and calculation.....	19
5.1.3 PFC Overcurrent protection circuit and PFC Gatekill configuration	20
5.2 Inverter section using CIPOS™ mini IPM.....	21







Table of contents

5.2.1	DC bus sensing and MCEWizard configuration	22
5.2.2	Motor External Current feedback configuration and calculation	23
5.2.3	Inverter Overcurrent protection and Motor Gatekill configuration	24
5.3	Thermistor/NTC Characteristics and protection calculation	25
5.3.1	CIPOS™ Internal NTC – Thermistor Characteristics	25
5.3.2	Overtemperature Hardware Protection Circuit	26
5.3.3	NTC shutdown value calculation and configuration	26
5.4	Auxiliary power supply	27
5.5	Schematics for EVAL-M3- CM615PN.....	28
5.6	PCB Layout for EVAL-M3- CM615PN.....	31
6	Bill of material	35
7	Reference.....	38
	Revision history.....	39

1 Safety precautions

In addition to the precautions listed throughout this manual, please read and understand the following statements regarding hazards associated with development systems.

Table 1 **Precautions**

	<p>Attention: <i>The ground potential of the EVAL-M3-CM615PN system is biased to a negative DC bus voltage potential. When measuring voltage waveform by oscilloscope, the scope's ground needs to be isolated. Failure to do so may result in personal injury or death and equipment damage.</i></p>
	<p>Attention: <i>Only personnel familiar with the drive and associated machinery should plan or implement the installation, start-up and subsequent maintenance of the system. Failure to comply may result in personal injury and/or equipment damage.</i></p>
	<p>Attention: <i>The surfaces of the drive may become hot, which may cause injury.</i></p>
	<p>Attention: <i>EVAL-M3-CM615PN system contains parts and assemblies sensitive to Electrostatic Discharge (ESD). Electrostatic control precautions are required when installing, testing, servicing or repairing this assembly. Component damage may result if ESD control procedures are not followed. If you are not familiar with electrostatic control procedures, refer to applicable ESD protection handbooks and guidelines.</i></p>
	<p>Attention: <i>A drive, incorrectly applied or installed, can result in component damage or reduction in product lifetime. Wiring or application errors such as under sizing the motor, supplying an incorrect or inadequate DC supply or excessive ambient temperatures may result in system malfunction.</i></p>
	<p>Attention: <i>Remove or connect the control board from or to the power drive. Wait three minutes after removing power from the power drive to discharge the bus capacitors. Do not attempt to service the drive until the bus capacitors have discharged to zero. Failure to do so may result in personal injury or death.</i></p>
	<p>Attention: <i>EVAL-M3-CM615PN system is shipped with packing materials that need to be removed prior to installation. Failure to remove all packing materials which are unnecessary for system installation may result in overheating or abnormal operating condition.</i></p>

Introduction

2 Introduction

The Eval-M3-CM615PN evaluation power board is a part of the iMOTION™ Modular Application Design Kit for motor drives (iMOTION™ MADK). In order to run a motor, the matching control board is required to interface this power board.

The MADK platform is intended to use various power stages with different control boards. These boards can easily be interfaced through the 30-pin iMOTION™ MADK M3 such as Eval-M3-102T, or the 20-pin iMOTION™ MADK M1 interface connector to control board. This board is equipped with 30-pin M3 connector and is intended for single motor control only.

This evaluation board is designed to give Easy-to-use power stage based on the Infineon's CIPOS™ Mini Intelligent Power Module (IPM). The board is equipped with all assembly groups for sensorless field oriented control (FOC). It provides a single-phase AC-connector, rectifier, a PFC inductor connector, Boost PFC and 3-phase output for connecting the motor. The power stage also contains emitter shunts for current sensing and a voltage divider for DC-link voltage measurement.

The Eval-M3-CM615PN evaluation board is available through regular Infineon distribution partners as well as on Infineon's website. The features of this board are described in the main features chapter of this document, whereas the remaining paragraphs provide information to enable the customers to copy, modify and qualify the design for production according to their own specific requirements.

Environmental conditions were considered in the design of the Eval-M3-CM615PN, but it is not qualified regarding safety requirements or manufacturing and operation over the whole operating temperature range or lifetime. The boards provided by Infineon are subject to functional testing only.

The block diagram of the Eval-M3-CM615PN is depicted in Figure 1. This evaluation board includes an EMI filter and soft power up circuit, 30 pins iMOTION™ MADK-M3 interface connector, auxiliary power supply to provide 15V and 3.3V, PFC gate drive circuit and the CIPOS™ Mini IPM IFCM15P60GD.

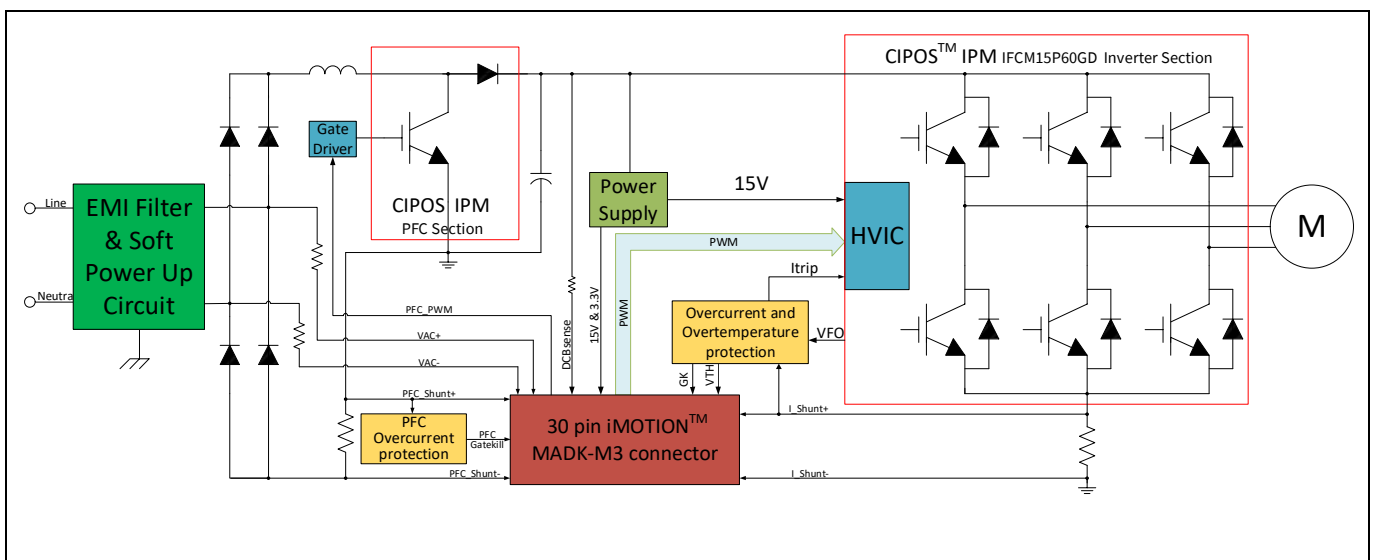

Figure 1 The Block Diagram of the Eval-M3-CM615PN

The hardware circuit regarding overtemperature and overcurrent protection is also included in this power board. The sense connection to common emitter shunt resistor is connected to the 30 pins iMOTION™ MADK-M3 interface connector. This power board is compatible with PFC integrated CIPOS™ Mini IPMs that feature 3 phase common emitter and built-in NTC considering motor power rating and IPM's current rating.

Introduction

Evaluation boards are not subject to the same procedures as regular products regarding Returned Material Analysis (RMA), Process Change Notification (PCN) and Product Discontinuation (PD). Evaluation boards are intended to be used under laboratory conditions by technical specialists only.

3 EVAL-M3-CM615PN main features

Eval-M3-CM615PN is an evaluation board for motor drive applications with single phase PFC integrated 3 phase IPM. Combined in a kit with one of the available MADK control board options, it demonstrates Infineon's motion control IC and IPM technology for motor drives with single phase PFC.

Main features of CIPOS™ Mini IPM IFCM15P60GD are:

- 3 half bridges with TRENCHSTOP™ IGBT3 15A/600V and antiparallel diodes for inverter section
- 30A/650V TRENCHSTOP™ 5 IGBT and rapid switching emitter controlled diode for PFC section
- Lead-free terminal plating; RoHS compliant
- Very low thermal resistance due to DCB
- Rugged SOI gate driver technology with stability against transient and negative voltage
- Negative potential allowed up to $V_S = -11V$ for single transmission at $V_{BS} = 15V$
- Integrated bootstrap functionality
- Overcurrent shutdown
- Temperature monitor
- Undervoltage lockout at all channels
- Low side common emitter
- Cross conduction prevention
- All six switches turn off during protection

The evaluation board characteristics are:

- Input voltage 160~265VAC
- Maximum 650W motor power output
- Power Factor Correction
- On board EMI filter
- Current sensing with single shunt
- Auxiliary power supply with 15V, 3.3V
- Overcurrent protection
- Overtemperature hardware protection
- Sensing of DC-link voltage
- Thermistor output
- Fault diagnostic output
- Measurement test-points compatible to standard oscilloscope probes
- PCB is 120 mm × 120 mm and has two layers with 35µm copper each
- RoHS complaint

3.1 EVAL-M3- CM615PN board specifications

Table 2 depicts the important specifications of the evaluation board Eval-M3-CM615PN.

Table 2 Eval-M3-CM615PN board specifications

Parameters	Values	Conditions / comments
Input		
Voltage	165 - 265 V _{rms}	lower AC input, less motor power output
Input current	3.15 A _{rms}	input 220 V _{AC} , T _a =25°C, IFCM15P60GD
Output		
Power (3phases)	650 W	input 220V _{AC} , f _{PWM} =6 kHz, T _a =25°C, T _h =80°C
Current per leg	2.32 A _{rms}	input 220V _{AC} , f _{PWM} =6 kHz, T _a =25°C, T _h =80°C
DC Bus Voltage		
Maximum DC bus voltage	420 V	
Minimum DC bus voltage	120 V	
Switching Frequency		
PFC switching frequency f _{PFC}	60 kHz (max)	Limited by controller board (maximum 50 kHz for Eval-M3-102T)
Inverter switching frequency f _{PWM}	20 kHz (max)	
Current feedback		
PFC current sensing resistor R1	30 mΩ	
Inverter current sensing resistor RS2	30 mΩ	R2 is the IPM inverter section's common emitter current sensing resistor.
Protections		
PFC Gatekill protection level	15.5 A _{peak}	Configured by either PFC current sensing resistor RS1, or adapting comparator threshold divider resistor R17.
Output current trip level	¹ 15.7 A _{peak}	Configured by changing shunt resistor RS2. ITRIP positive going threshold is about 470mV.
Temperature trip level	100 °C	For controller board Eval-M3-188
On board power supply		
15 V	15 V ± 5 %, max. 50 mA	Used for CIPOS™ IPM gate driver and LDO
3.3 V	3.3 V ± 2 %, max. 20 mA	Supplying the 3.3V to the controller board and protection circuits
PCB characteristics		
Material	FR4, 1.6mm thickness, 2 layers. 35 μm copper thickness	
Dimension	120 mm x 120 mm	
System environment		
Ambient temperature	From 0 to 50°C	Non-condensing, maximum RH of 95 %

¹ For iMOTION™ IC IMC1xx, there are three types of Gatekill Input Source (Refer to section 5.2.3 or control board user manual for detail). Please note that, if select comparator for Gatekill Input Source, the external Gatekill signal will be not used. And the signal I_Shunt will be compared by the internal comparator with the "Gatekill Comparator Reference" value set in MCEWizard only.

Figure 2 points out the functional groups on the top side of the Eval-M3-CM615PN evaluation board.

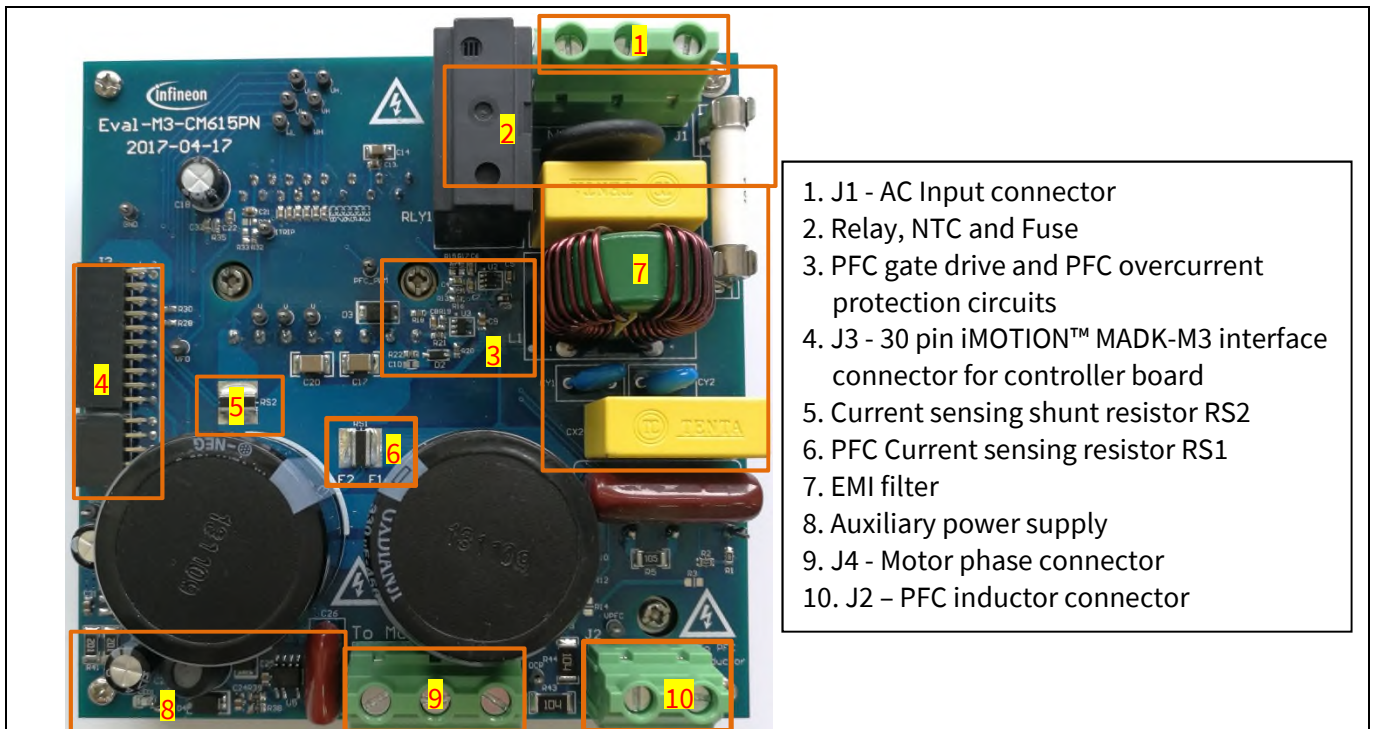

Figure 2 Functional groups of the Eval-M3-CM615PN evaluation board's top side

Figure 3 points out the functional groups on the bottom side of the Eval-M3-CM615PN evaluation board.

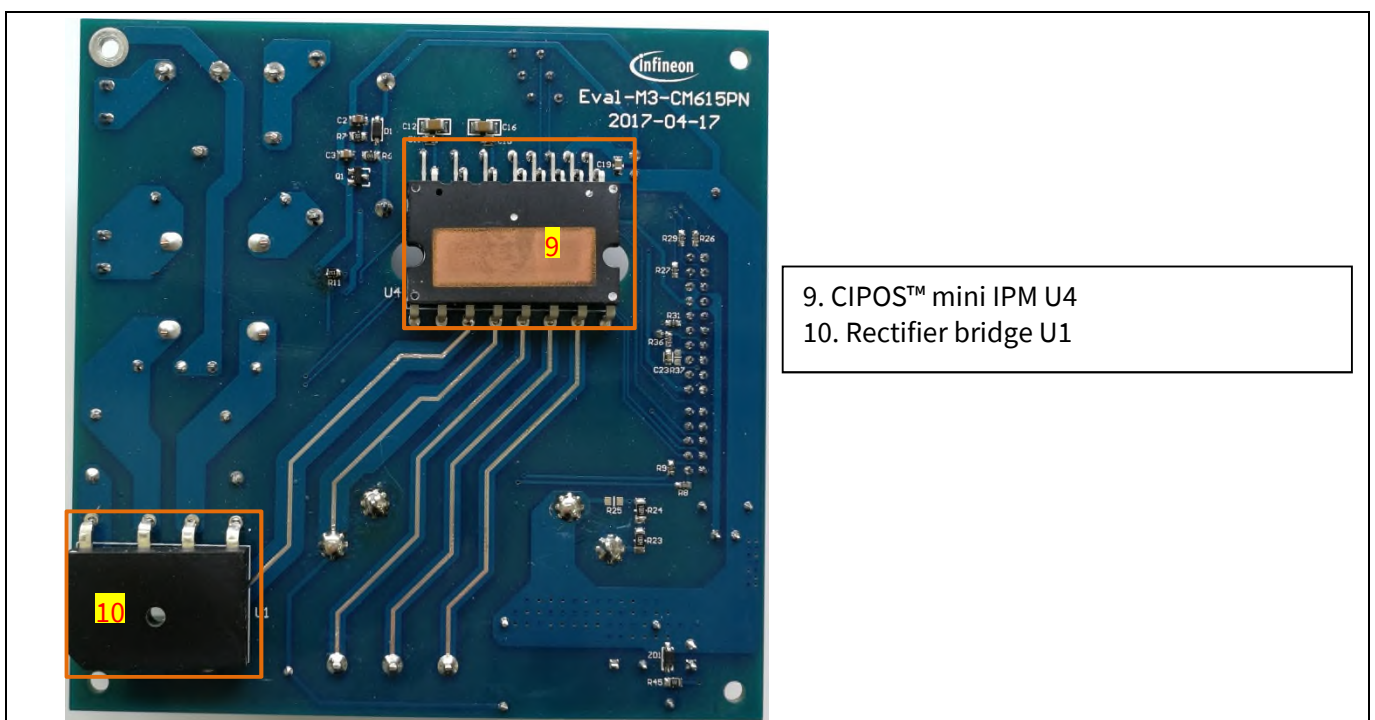

Figure 3 Functional groups of the Eval-M3-CM615PN evaluation board's bottom side

3.2 Pin assignment

General information about the connectors of the Eval-M3-CM615PN evaluation board is reported. Table 3 includes the details of the AC input connector J1.

Table 3 J1- AC Line connector

S. No.	Pin	Details
1	Neutral	AC neutral input
2	Earth	Earth ground
3	Line	AC line input

Table 4 denotes the details of the PFC inductor connector J2.

Table 4 J2- DC link connector

S. No.	Pin	Details
1	L+	Connected to one side of PFC inductor
2	L-	Connected to the other side of PFC inductor

Table 5 provides the details of the motor side connector J4.

Table 5 J4- Motor side connector

S. No.	Pin	Details
1	U	Connected to motor phase U
2	V	Connected to motor phase V
3	W	Connected to motor phase W

Table 6 provides the pin assignments of the 30 pins iMOTION™ MADK-M3 interface connector J3. This connector is the interface to the controller board.

Table 6 J3 - iMOTION™ MADK-M3 30 pin interface connector for controller board

Pin	Name	Pin Name Connectors
1	PWMUH	3.3 V compatible logic input for high side gate driver-Phase U
2	GND	Ground
3	PWMUL	3.3 V compatible logic input for low side gate driver-Phase U
4	GND	4 GND Ground
5	PWMVH	3.3 V compatible logic input for high side gate driver-Phase V
6	+3.3V	On board 3.3 V supply
7	PWMVL	3.3 V compatible logic input for low side gate driver-Phase V
8	+3.3V	On board 3.3 V supply
9	PWMWH	3.3 V compatible logic input for high side gate driver-Phase W
10	I_U	Positive Current sense output

EVAL-M3-CM615PN main features

Pin	Name	Pin Name Connectors
11	PWMWL	3.3 V compatible logic input for low side gate driver-Phase W
12	I_U-	Negative current sense output or Ground
13	GK	Gate kill signal – active low when overcurrent is detected
14	DCBSense	DC bus positive voltage, scaled in 0-3.3 V range by a voltage divider
15	VTH	Thermistor Output
16	I_V	Not used
17	I_V-	Not used
18	I_W	Not used
19	I_W-	Not used
20	VCC	15 V Power Supply
21	PFCG0	3.3 V compatible logic input for PFC gate driver IC
22	GND	Ground
23	PFCG1	Not used
24	+3.3V	On board 3.3 V supply
25	PFCGK	PFC Gate kill signal – active low when PFC overcurrent is detected
26	DCBSense	DC bus positive voltage, scaled in 0-3.3 V range by a voltage divider
27	VAC+	AC voltage sensing positive cycle
28	VAC-	AC voltage sensing negative cycle
29	IPFC+	PFC current sensing positive
30	IPFC-	PFC current sensing negative

4 Getting Started with EVAL-M3-CM615PN

In order to run the motor system, a combination of the iMOTION™ MADK power board (EVAL-M3-CM615PN) and the matching MADK control board is required. The iMOTION™ Software Tools MCEDesigner and MCEWizard are also required in order to initially setup the system, as well as to control and fine-tune the system performance to match users exact needs. This chapter provides more details on setting up the system and getting started with iMOTION™ MADK development platform.

4.1 Setting up the system

After downloading and installing the iMOTION™ PC Tools (MCEWizard and MCEDesigner), following steps needs to be executed in order to run the motor. Refer to user manual for iMOTION™ MADK control board such as (EVAL-M3-102T), MCEWizard and MCEDesigner documentation for more information.

Figure 4 shows the system connection using EVAL-M3-CM615PN and control board (used control board EVAL-M3-102T for example).

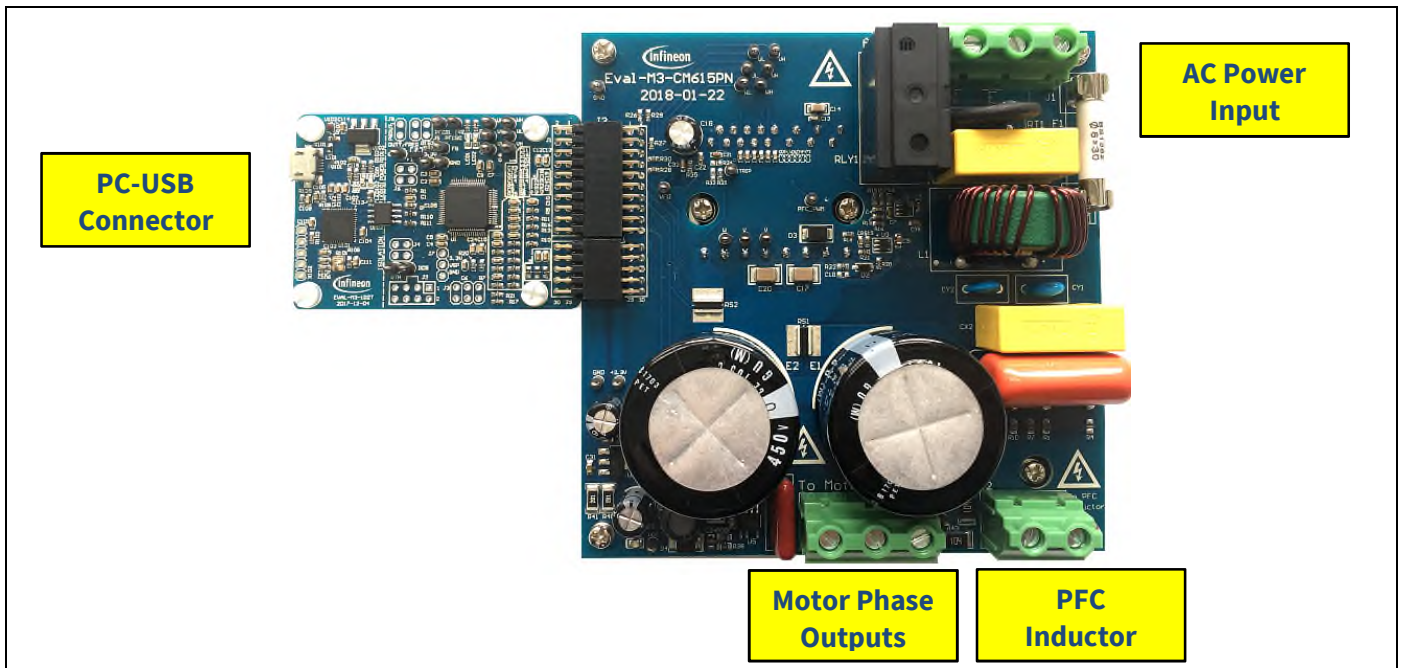

Figure 4 System connection example using EVAL-M3-CM615PN and EVAL-M3-102T

1. Connect PC-USB connector on the on-board-debugger to the PC via USB cable.
2. Connect EVAL-M3-CM615PN's MADK M3 30-pin interface connector (J3) to control board (see Figure 4).
3. Get the latest "IMC102T-F064 MCE Software Package" available on www.infineon.com/imotion-software web page. (Infineon iMOTION™ control IC IMC102T-F064 is used for control board EVAL-M3-102T).
4. Connect motor phase outputs to the motor.
5. Use MCEWizard to enter the motor and evaluation board hardware parameters and click button "Export to Designer file (.txt)" to system drive parameters file which will be used by MCEDesigner.
6. Connect AC power to power input connector and power on system.
7. Open MCEDesigner and open MCEDesigner default configuration file (.irc) for IMC102T devices (IMC102T_xx.irc) by clicking "File" menu and select "Open" in the pull down list.
8. Import system drive parameters file (generated in step 5) into MCEDesigner by clicking "File" > "Import Drive Parameters". Select "Update All" radio button.

Getting Started with EVAL-M3-CM615PN

9. Program the MCE Firmware and system parameters into the internal Flash memory of iMOTION™ IC by clicking “Tools > Programmer” in the pull down menu, and then clicking on the “Program Firmware and Parameter” radio button. See chapter MCEDesigner setup overview section 4.2.2 for more details. If the latest version of MCE firmware is already programmed into the IMC102T-F064 IC, then programming firmware can be skipped by selecting “Program Parameters” radio button option. Finally click “Start” button to program firmware and parameter (or parameters only when programming firmware was skipped).
10. Start the motor by clicking the green traffic light button in the control bar.

4.2 iMOTION™ development tools and software

The iMOTION™ Development Tool installers for MCEDesigner and MCEWizard are available for download via Infineon iMOTION™ website (<http://www.infineon.com/imotion-software>). All the available tools and software variants are listed there.

On-board debugger uses the SEGGER J-Link’s driver for UART communication with IMC102T-F064. J-Link driver will be installed during the MCEDesigner installation. In case the driver is not installed properly, please go to [SEGGER J-Link website](#) to download and install the latest J-Link “Software and Documentation pack for Windows”.

4.2.1 MCEWizard setup overview

After installing the MCEWizard, the shortcut for MCEWizard appears on the Windows desktop. Double click the shortcut to open the MCEWizard and configure the parameters for evaluation boards or motor. Figure 6 shows the “Welcome Page” for MCEWizard, where the MADK control board or power board can be selected through the pull-down list. Infineon keeps releasing new MADK controller and power boards. Therefore, it could happen that some of the newest power boards are not pre-configured in the MCEWizard tool and cannot be selected through the pull-down menu. In that case, the user should select any other power board (as similar as possible) and follow the MCEWizard setup steps by entering the parameter values which are specific to the chosen board. Make sure both “I have modified the circuit board” and “Enable advanced question” checkmarks are selected. Please refer to the User Manual of the corresponding power board for additional information.

After selecting the MADK control and the power board, start the MCEWizard system setup procedure by clicking the “Next” button in the right bottom corner as shown in Figure 6.

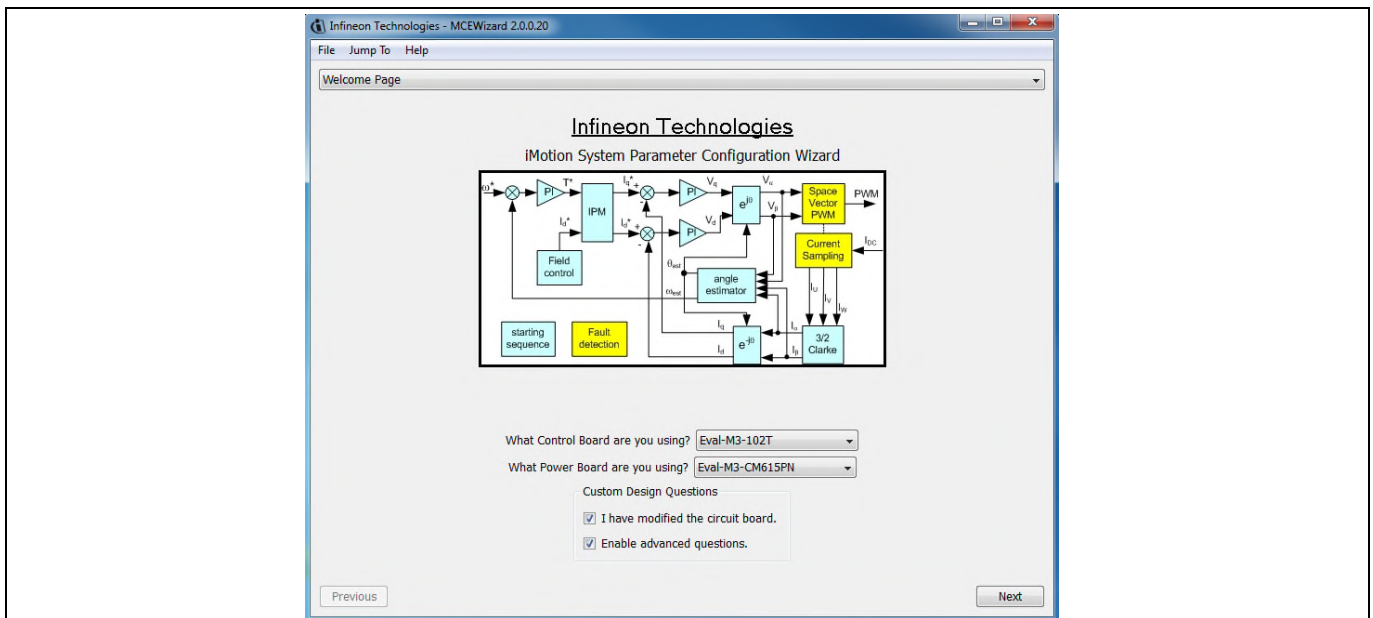

Figure 5 Welcome Page of MCEWizard

iMOTION™ MADK system enables users to easily test different combination of control and power board with their motors. User should be familiar with the system level parameters which are related to the motor used. There are very limited numbers of parameters which are specific to the control board or power board hardware. Table 7 provides the MCEWizard setup overview for hardware related parameters. Similar tables will be available in each power board’s User Manual. Combination of this table and the corresponding table of the power board provides enough information to setup the MADK-based motor drive system in shortest time.

Table 7 MCEWizard setup overview table

Page	Parameter	Value	Comment
Welcome Page	Power Board selecting	MADK power board name	If no, select similar power board to modify
Options Page	Motor 1 Shunt Configuration	30mΩ	
Question 3	Controller Supply Voltage	Refer to control board user manual	
Question 19	Max DC Bus Voltage	420V	
Question 23	DC Bus Sensing High Resistor	2MΩ	
Question 24	DC Bus Sensing Low Resistor	Refer to control board user manual	13.3kΩ by default
Question 54	NTC Temperature Shutdown value	Calculated as the Section 5.3.3	Refer to the control board user manual
Question 63	GateSense Low-Side Devices	High is true	
Question 64	GateSense High-Side Devices	High is true	
Question 69	Motor 1 Current Input	Calculated as the Section 5.2.2	
Question 83	PFC Topology	Boost PFC	
Question 85	PFC Current Input	Calculated as the Section 5.1.2	
Question 90	AC Voltage Sensing High Resistor	2000kΩ	
Question 91	AC Voltage Sensing low Resistor	Refer to control board user manual	15kΩ by default for EVAL-M3-102T
Question 92	PFC Gate Driver Polarity High Side	High is active	no high side, just compatibility
Question 93	PFC Gate Driver Polarity Low Side	High is active	

After all the MCEWizard questions are answered, the “Verify & Save Page” will be shown as in Figure 6

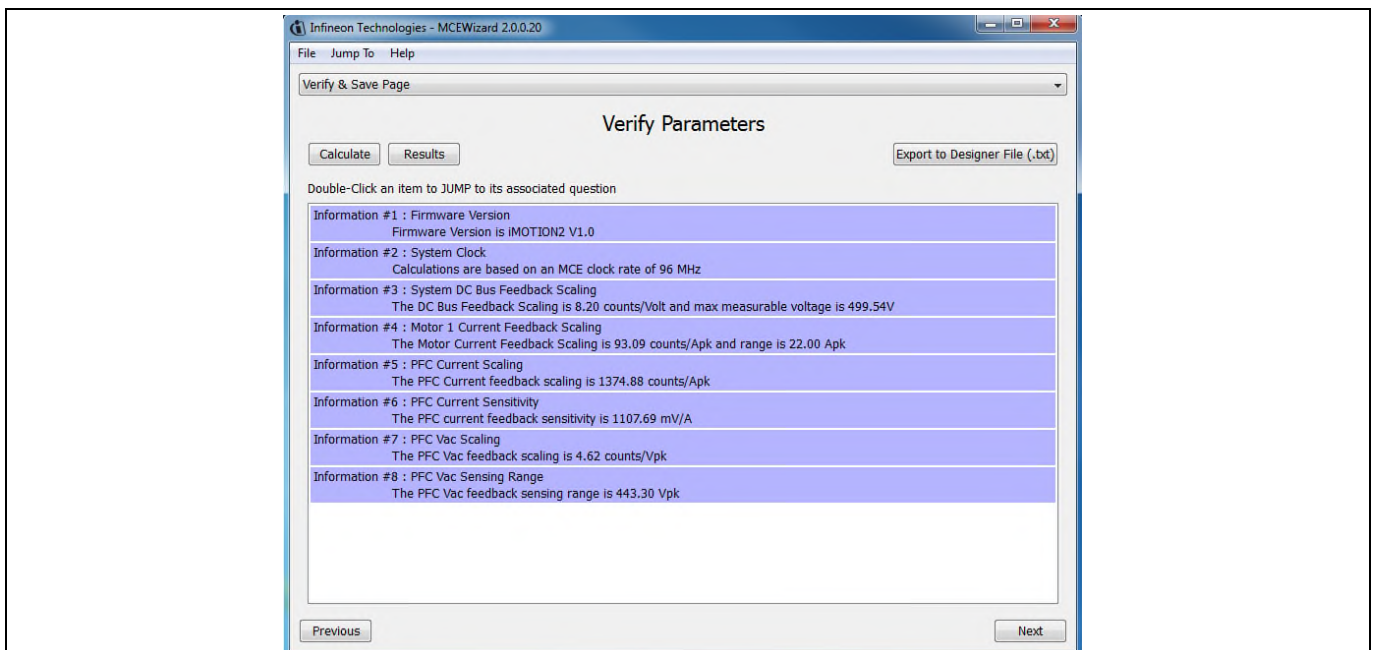

Figure 6 Verify and Save page for MCEWizard

Click “Calculate” button and “Export to Designer File (.txt)” button to save the parameter file which will be used by the MCEDesigner in the next steps.

4.2.2 MCEDesigner setup overview

After installing MCEDesigner installer, there is a shortcut for MCEDesigner on Windows desktop. Double click the shortcut to open MCEDesigner and then open “IMC102T_xx.irc” file as shown in Table 7.

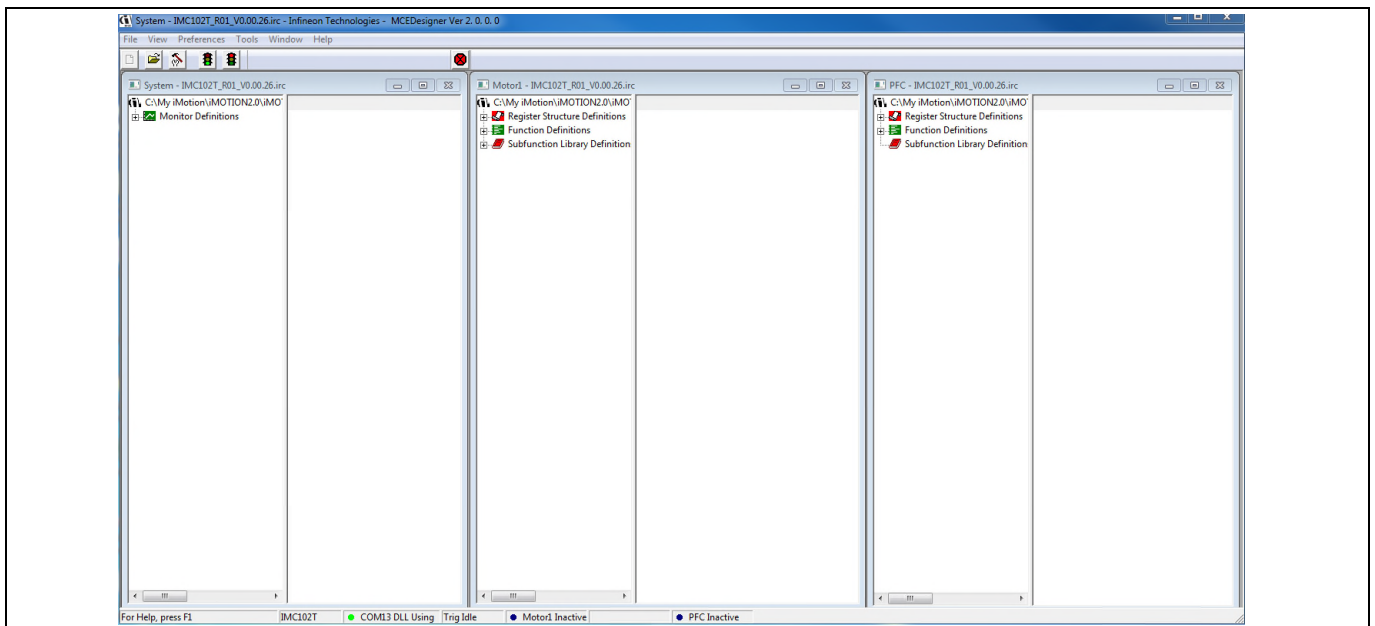

Figure 7 MCEDesigner’s Main Display for EVAL-M3-102T

To program system drive parameters into IMC102T-F064, please click “Tools” menu and select “Programmer” in the pull down list. The pop-up window “Program IMC controller” will show up as in Figure 8. Click on the “Program Parameters” radio button (this is the default option), and then select the Drive System Parameter file created using MCEWizard by clicking on “Browse”. Finally, click on the “Start” button to program the parameter file into the IMC102T-F064 IC.

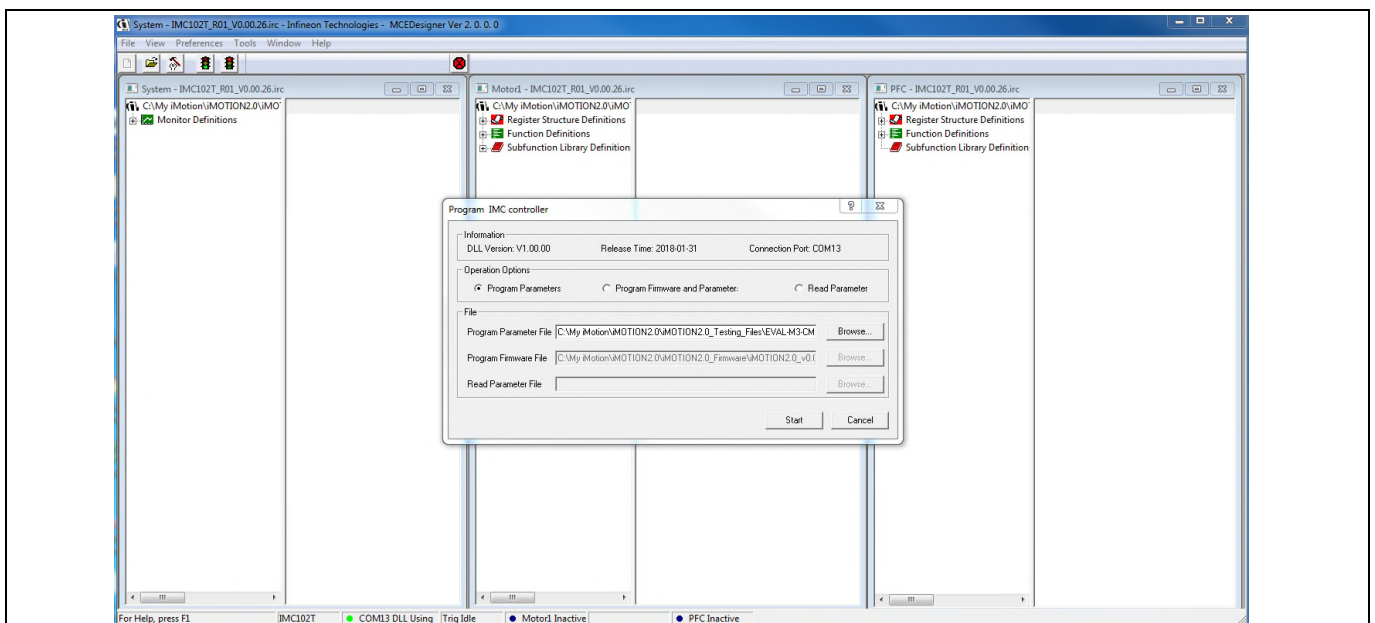

Figure 8 “Program IMC Controller” pop-up window

After Drive System Parameter file has been programmed into IMC102 controller, and the motor drive system is powered, the MCEDesigner can be used to start/stop the motor, display motor current traces, change the motor speeds, modify drive parameters and many other functions. Please refer to the MCEDesigner documentation for more details.

Note: On-board Debugger portion of EVAL-M3-102T is galvanically isolated from the controller portion and the attached power board. In order to program the parameters or firmware to the IMC102T-F064 controller, the 3.3V DC voltage needs to be supplied to the controller portion of the EVAL-M3-102T. This voltage can either be supplied by the power board (MADK power boards are designed to supply the 3.3V to the control board through M3 connector) or by feeding the 3.3V DC voltage to the control board through some of the available 3.3V access/test points if the power board is not attached to the EVAL-M3-102T control board.

To program new firmware and Drive System Parameter into IMC102T-F064, please click “Tools” menu and select “Programmer” in the pull down list. The pop-up window “Program IMC controller” will show up as in Figure 9. Click on the “Program Firmware and Parameter” radio button, and select the Drive System Parameter file created using MCEWizard by clicking on the “Browse” button on the row of “Program Parameter File”, and then select the firmware file by clicking on the “Browse” button on the row of “Program Firmware File”. Finally, click on the “Start” button to program the parameter file into the IMC102T-F064 IC.

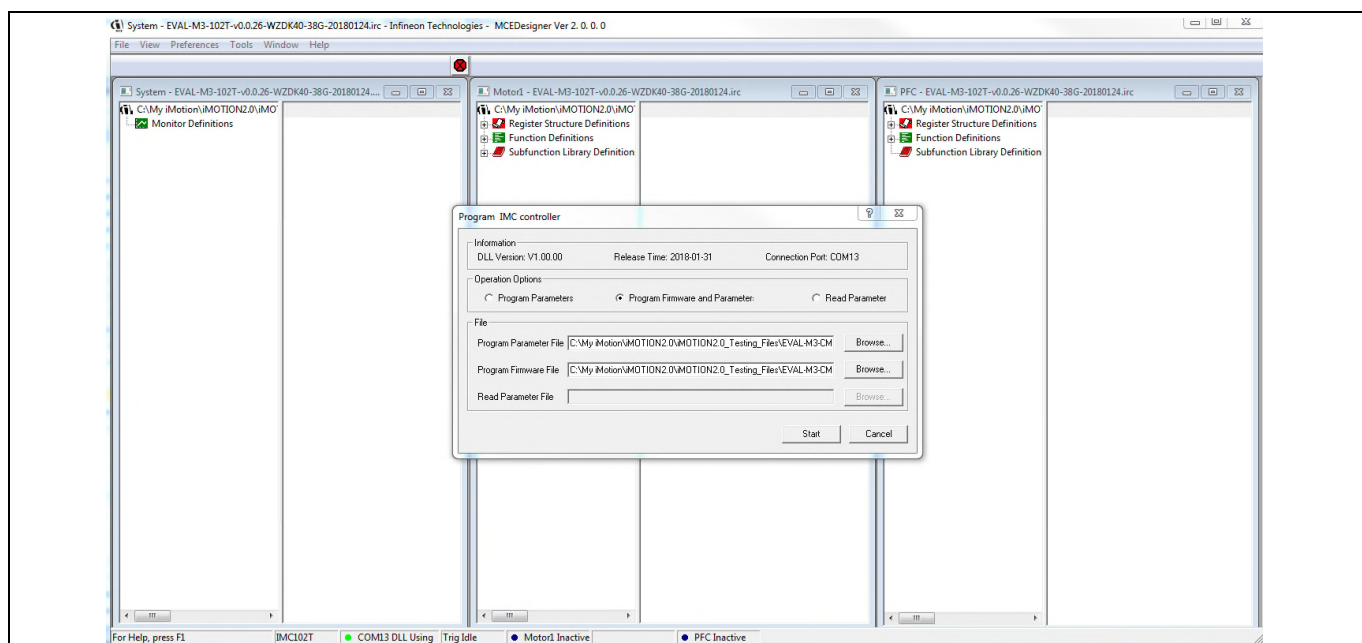

Figure 9 Program Firmware and Parameter in “Program IMC Controller” pop-up window

All latest firmware file for different type of iMOTION™ control ICs are available for download via Infineon iMOTION™ website (<http://www.infineon.com/imotion-software>).

5 Hardware description of EVAL-M3-CM615PN

To meet individual customer requirements and make the Eval-M3-CM615PN evaluation board a basis for development or modification, all necessary technical data like schematics, layout and components are included in this chapter.

5.1 Boost PFC section using CIPOS™ mini IPM

Figure 10 depicts the schematic from the AC input connector J1 to the rectified DC bus voltage DCP. This circuitry includes a passive EMI filter consisting of elements CX1, CX2, L1, CY1 and CY2, a 25 A/600 V rectifier bridge U1, a fuse F1 for inrush current protection, a NTC resistor RT1 and a relay RLY1 for soft powering up and reducing conduction losses in steady state. The PFC section is implemented using the CIPOS™ mini IPM as sketched in Figure 10. The IRS44273L is used to drive IGBT for PFC section. A PFC inductor should be connected to J2. PFC inductor is included in this evaluation kit.

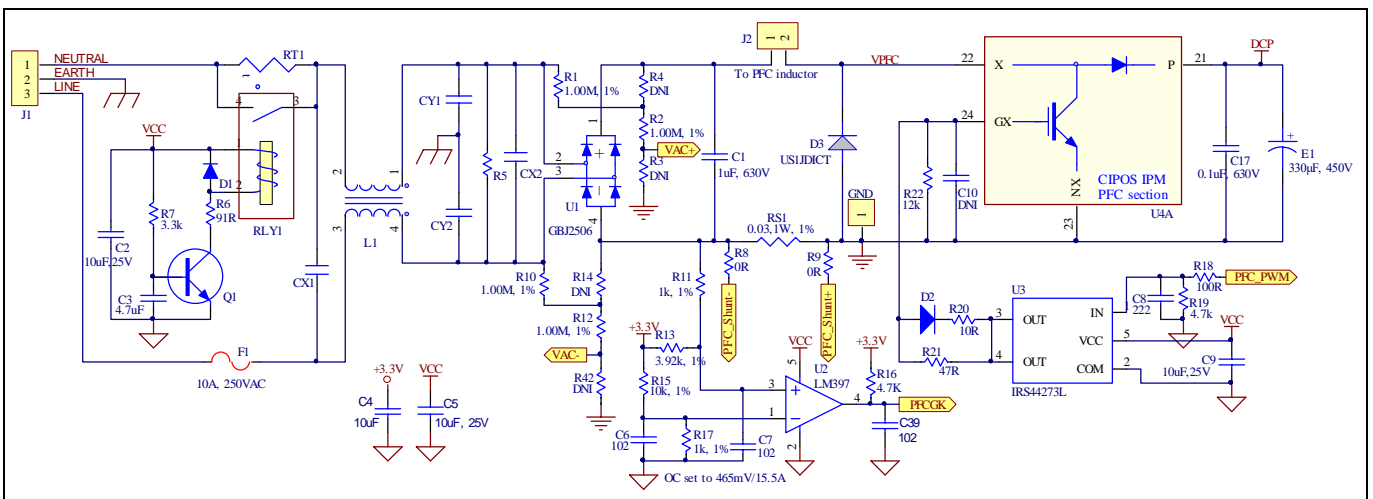

Figure 10 Schematic for EMI filter and PFC section of the Eval-M3-CM615PN evaluation board

The PFC section of CIPOS™ IPM IFCM15P60GD contains a TRENCHSTOP™ 5 IGBT and a rapid switching emitter controlled diode. The PFC IGBT's anti-parallel diode D3 is mandatory. For 650W power output, the inductance of PFC inductor should be larger than 3mH. Two electrolytic capacitors E1 and E2 are used for buffering the rectified DC bus voltage DCP.

5.1.1 AC Voltage sensing and MCEWizard configuration

AC voltage sensing is in the front of rectifier bridge U1 by default as shown in Figure 10. To drive the boost PFC circuitry for EVAL-M3-CM615PN, the default matching MADK control board is EVAL-M3-102T. Figure 11 shows the VAC sensing schematic of EVAL-M3-102T evaluation board.

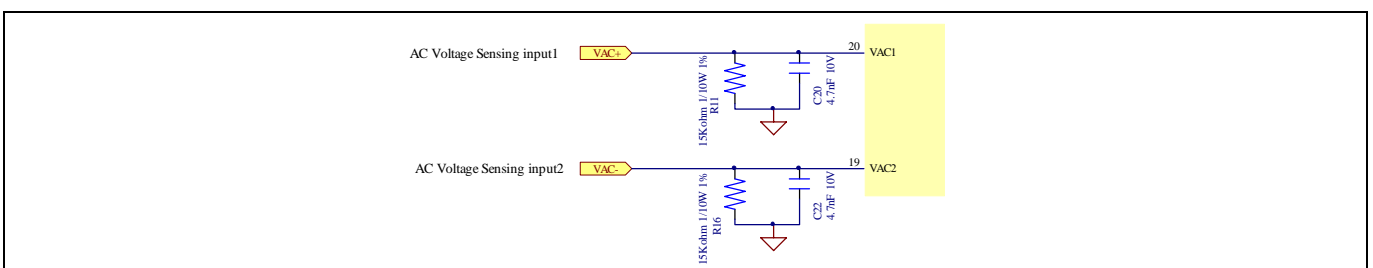

Figure 11 The AC Voltage sensing schematic of EVAL-M3-102T

There are two AC voltage sensing modes in MCEWizard, differential mode and single-ended as shown in Figure 12. Please select differential mode for the combination between EVAL-M3-CM615PN and EVAL-M3-102T.

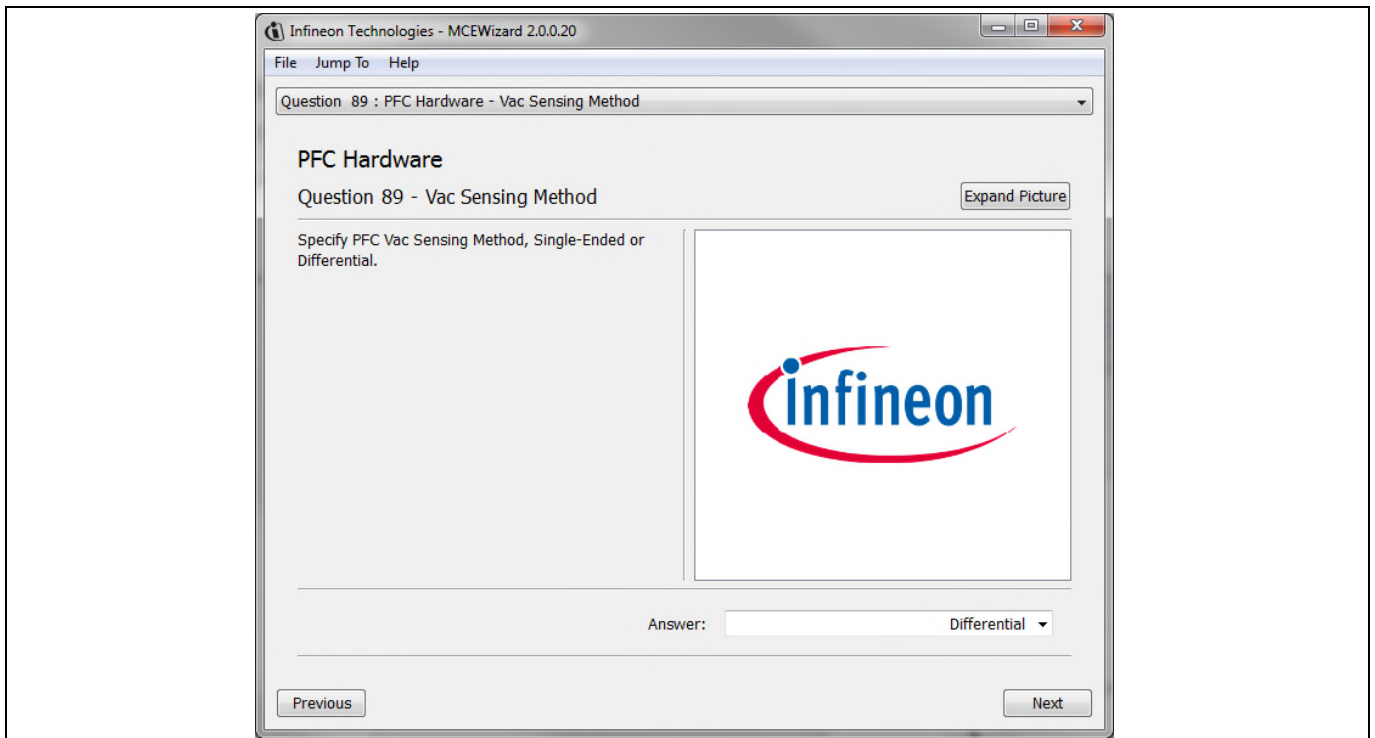

Figure 12 Vac Sensing Method configuration for EVAL-M3-102T and EVAL-M3-CM615PN

The high side resistors R1 and R2 or R12 and R14 for the AC voltage sensing resistor divider on the power board EVAL-M3-CM615PN is 2000kΩ, and should be configured in MCEWizard as shown in Figure 13. For the low side resistor value, please refer to the User Manual of the corresponding control board.

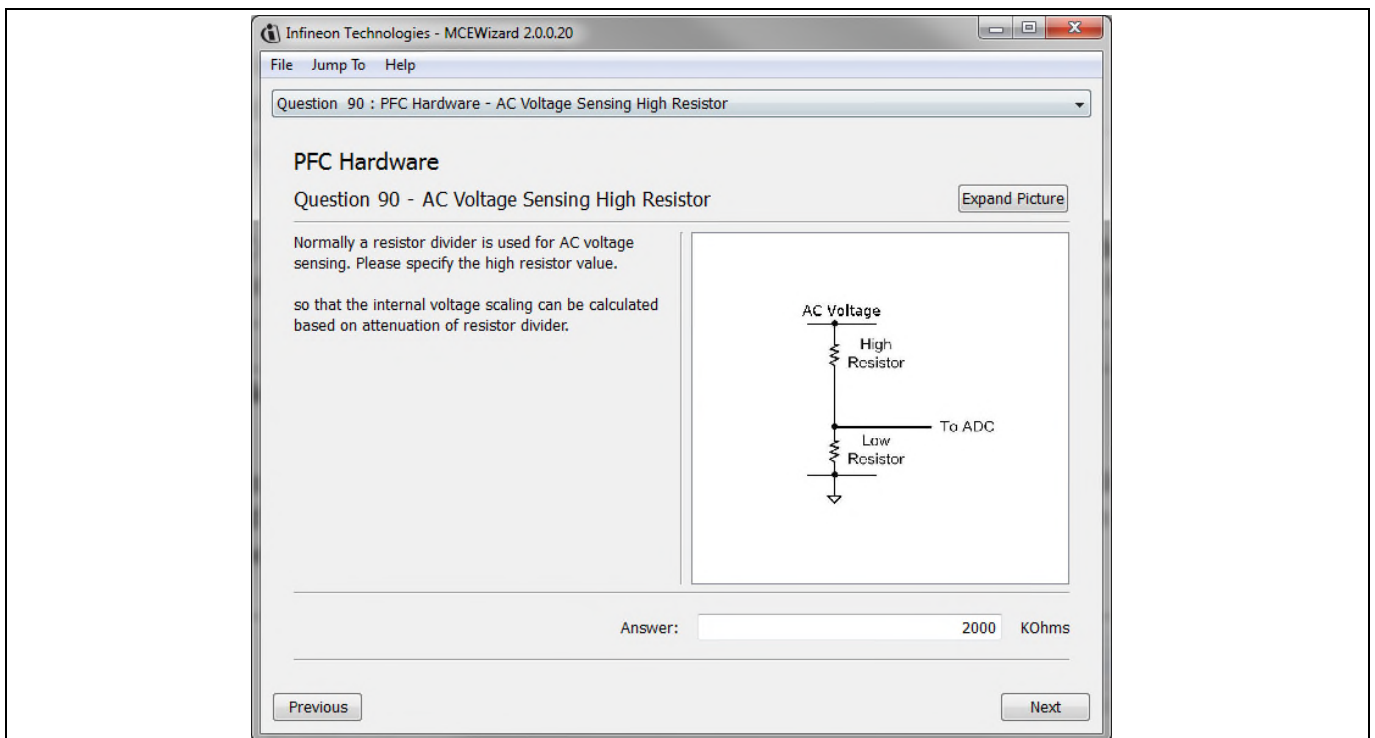

Figure 13 AC Voltage sensing configuration in MCEWizard

5.1.2 PFC External Current feedback configuration and calculation

The PFC shunt resistor RS1 is 30mΩ for EVAL-M3-CM615PN. But for control board EVAL-M3-102T, the current input value is product of the shunt resistance in milliohms and gain of External current sense amplifier as shown in Figure 14.

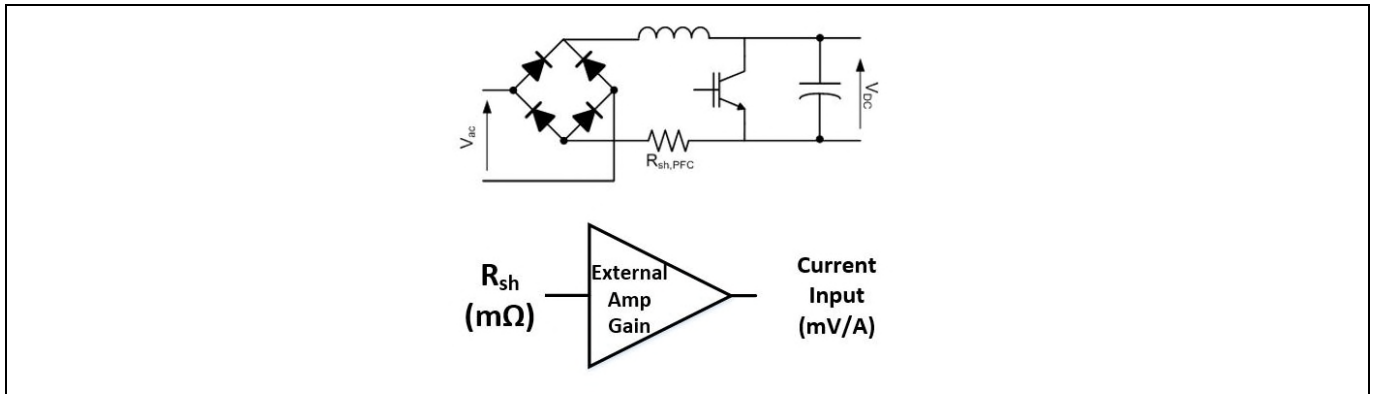

Figure 14 PFC Current shunt feedback and sample timing

Figure 15 depicts IPFC- current feedback sensing circuitry on EVAL-M3-102T evaluation board. Please note that the default external amplification gain is less than 1 for current sense in this evaluation board.

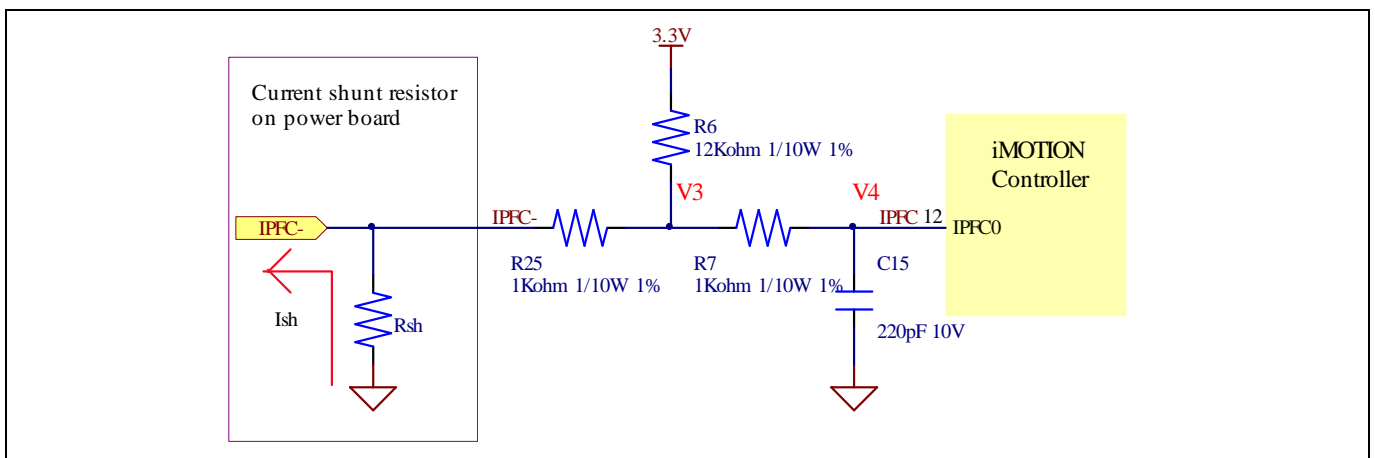

Figure 15 The PFC Current feedback circuit for EVAL-M3-102T evaluation board

Based on the principle of Kirchoff's voltage law,

$$V_4 \approx V_3 \approx (V_{DD} + I_{sh} * R_{sh}) * \frac{R_{25}}{R_6 + R_{25}} - I_{sh} * R_{sh} = \frac{R_{25}}{R_6 + R_{25}} V_{DD} - \frac{R_6}{R_6 + R_{25}} R_{sh} * I_{sh}$$

$$Current\ input = \frac{R_6}{R_6 + R_{25}} R_{sh} = \frac{12}{13} R_{sh}$$

Based on this calculation, the current input for the MADK combination of EVAL-M3-102T and EVAL-M3-CM615PN is 27.69 mV/A. Please use same procedure to calculate the current input for other combinations of MADK boards and enter it into MCEWizard.

5.1.3 PFC Overcurrent protection circuit and PFC Gatekill configuration

PFC protection circuit for EVAL-M3-CM615PN as shown in Figure 16, but the left side of RS1 is negative. If the bus current I_{bus} is larger than the setting value, the output PFCGK of U2 will be trigger low and be active.

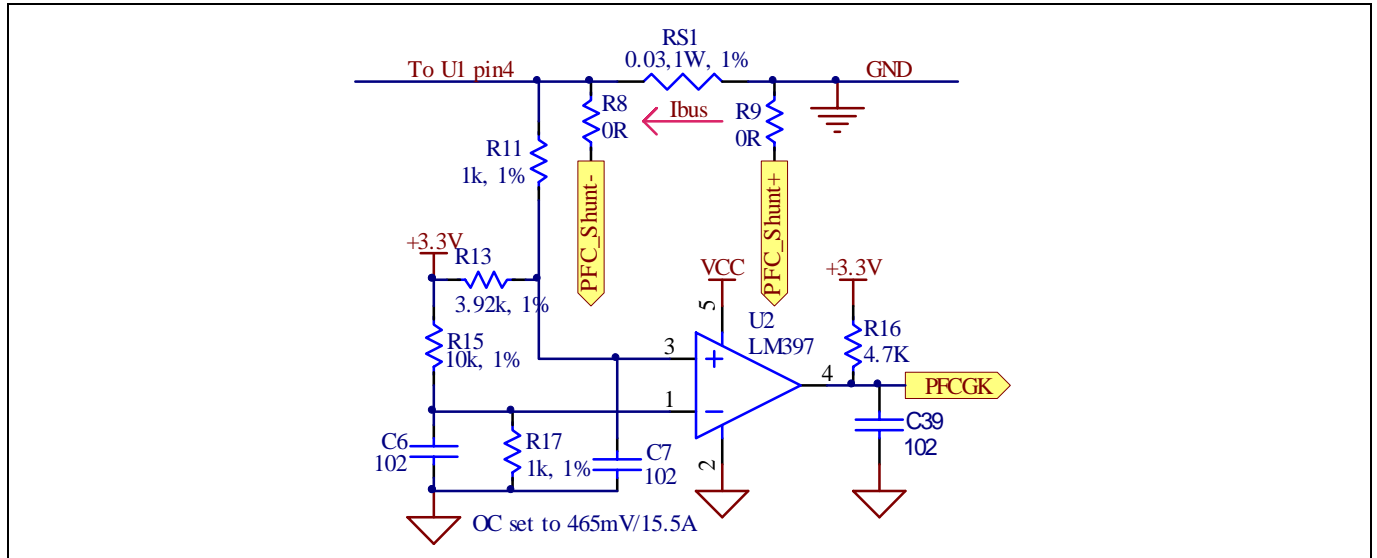

Figure 16 PFC protection Circuit on the EVAL-M3-CM615PN evaluation board

The PFCGK active setting current is 15.5A for EVAL-M3-CM615PN evaluation board. And the calculation formula is as follows,

$$I_{PFCGK} = \frac{\left(\frac{R_{11}}{R_{11} + R_{13}} - \frac{R_{17}}{R_{17} + R_{15}} \right) * V_{DD}}{\frac{R_{11}}{R_{11} + R_{13}} R_{S1}} = \frac{\left(\frac{R_{11}}{R_{13}} - \frac{(R_{11} + R_{13}) * R_{17}}{(R_{17} + R_{15}) * R_{13}} \right) * V_{DD}}{R_{S1}}$$

Please attention that for control board EVAL-M3-102T, it doesn't use the external PFC gatekill signal PFCGK.

Note: PFC Overcurrent protection circuit just generates the signal of PFCGK, and there is no more action for EVAL-M3-CM615PN. The power board will not turn off the PFC gate driver IC if the control board doesn't do anything when PFCGK is active.

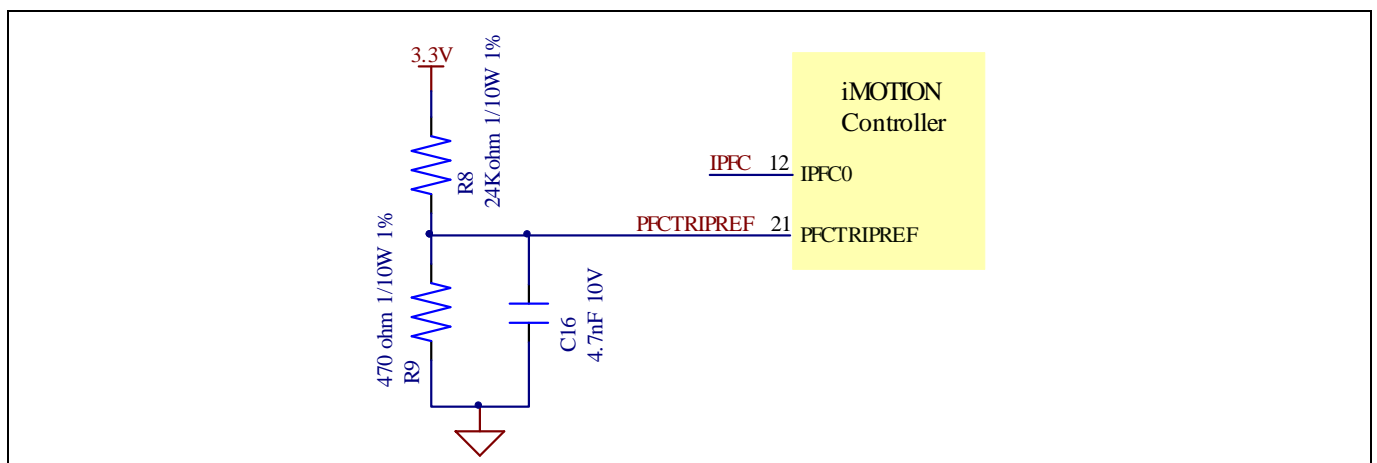

Figure 17 The PFCTRIPREF Circuit on the EVAL-M3-102T evaluation board

EVAL-M3-CM615PN User Manual

iMOTION™ Modular Application Design Kit

Hardware description of EVAL-M3-CM615PN

The PFC’s overcurrent protection circuit on the control board EVAL-M3-102T is shown in Figure 15 and Figure 17. The $I_{PFCTRIP_Peak}$ equal to 6.347A for the combination between EVAL-M3-102T and EVAL-M3-CM615PN only.

The calculation formula is as follows,

$$I_{PFCTRIP_Peak} = \frac{\left(\frac{R_9}{R_8 + R_9} - \frac{R_6}{R_6 + R_{25}} \right) * V_{DD}}{R_{S1}}$$

If larger PFC current protection setting value needed, please use smaller resistance of PFC shunt resistor R_{S1} , or modify the control board EVAL-M3-102T following the previous formula. Please refer to the control board’s user manual for more details.

5.2 Inverter section using CIPOS™ mini IPM

The inverter section is also implemented using the CIPOS™ mini IPM as sketched in Figure 18. The inverter section of IPM module includes an optimized SOI gate driver and a three-phase inverter consisting of TRENCHSTOP™ IGBTs and anti parallel diodes.

The three pairs of capacitors C11 and C12, C13 and C14, C15 and C16 are used as bootstrap capacitors to provide the necessary floating supply voltages V_{BS1} , V_{BS2} and V_{BS3} respectively.

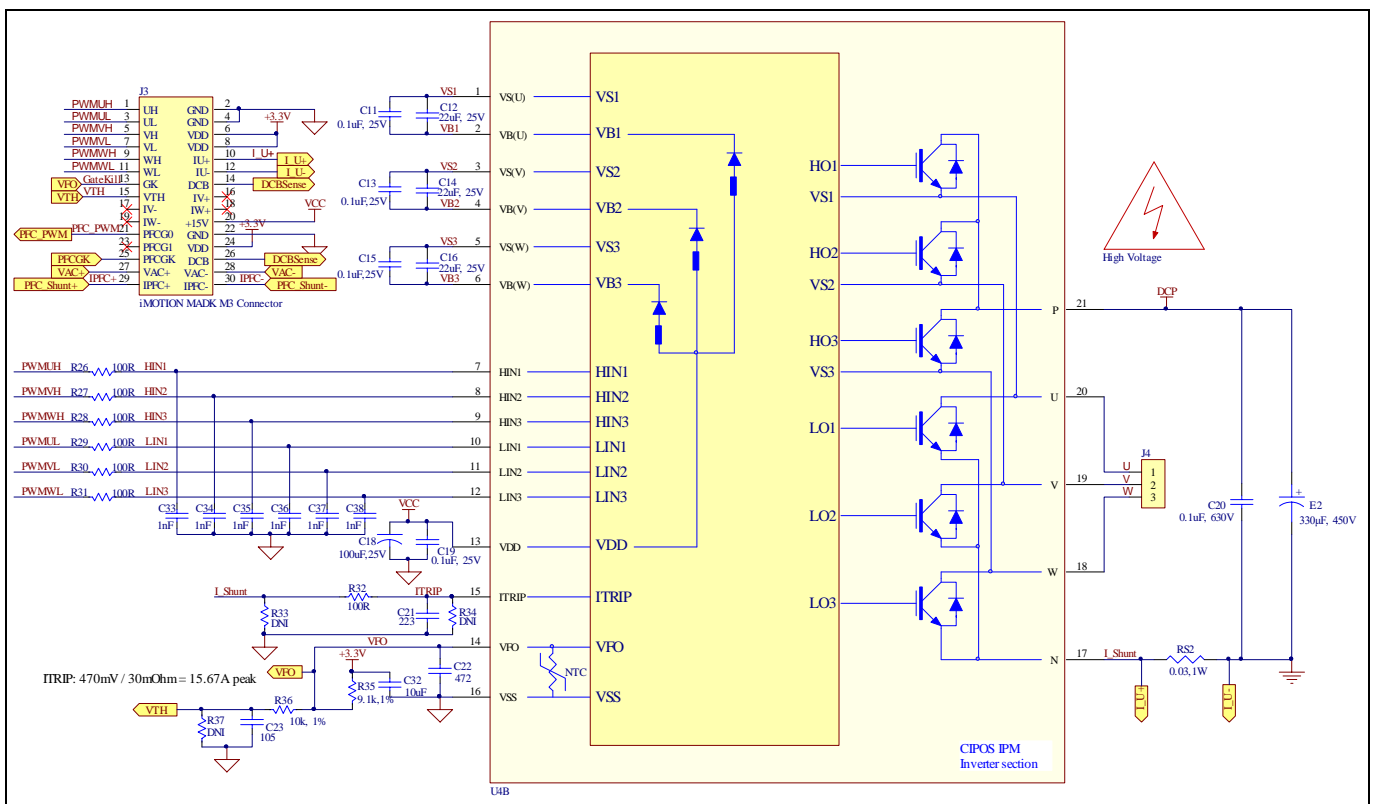

Figure 18 Schematic of the 3-phase inverter section using CIPOS™ mini IPM on Eval-M3-CM615PN

5.2.1 DC bus sensing and MCEWizard configuration

Pin 14 and pin 26 of connector J3 provide access to the DC-link voltage DCBSense. Three possible feedback cases are associated with these pins. Figure 19 provides the DC bus sense resistor details. By default, the resistor R25 is not mounted on Eval-M3-CM615PN. There must be a pull-down resistor mounted on the corresponding controller board.

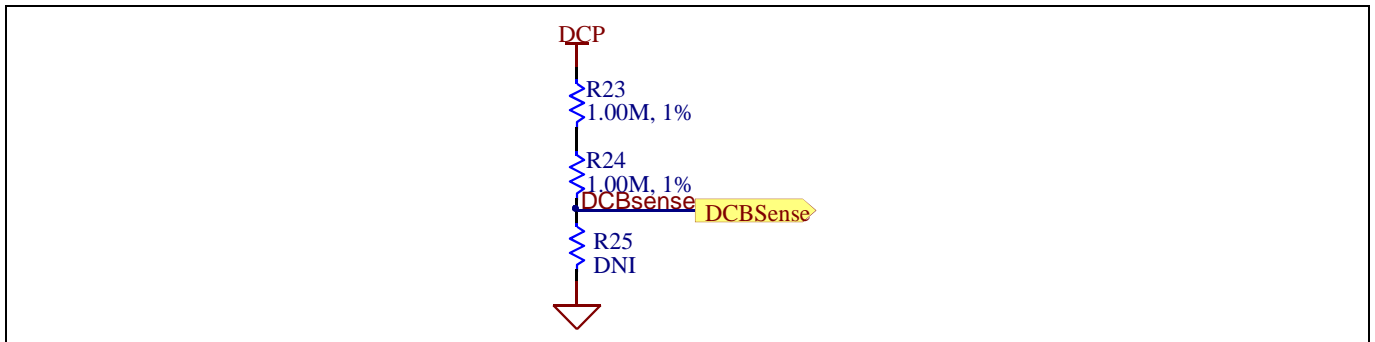

Figure 19 DC bus sense resistor on Eval-M3-CM615PN evaluation board

If a pull down resistor of 13.3 kΩ referred to ground is inserted either on the Eval-M3-CM615PN evaluation board or on the control board, the DCBSense voltage results in the range of 0 to 3.3 V on the pin reflecting a DC bus voltage range of 0 to 420 V. If a pull down resistor of 13.3 kΩ is inserted on both, Eval-M3-CM615PN evaluation board and on the control card, the DCBSense results scale to 0-1.65 V. No safety issue occurs. If no feedback is desired on the DCBSense pin, R23 or R24 should be removed to avoid high voltage on the connector.

The high side resistors R23 and R24 for the DC bus sensing resistor divider on the controller board EVAL-M3-CM615PN are 2000kΩ, and should be configured in MCEWizard as shown in Figure 20. For the low side resistor value, please refer to the User Manual of the corresponding control board.

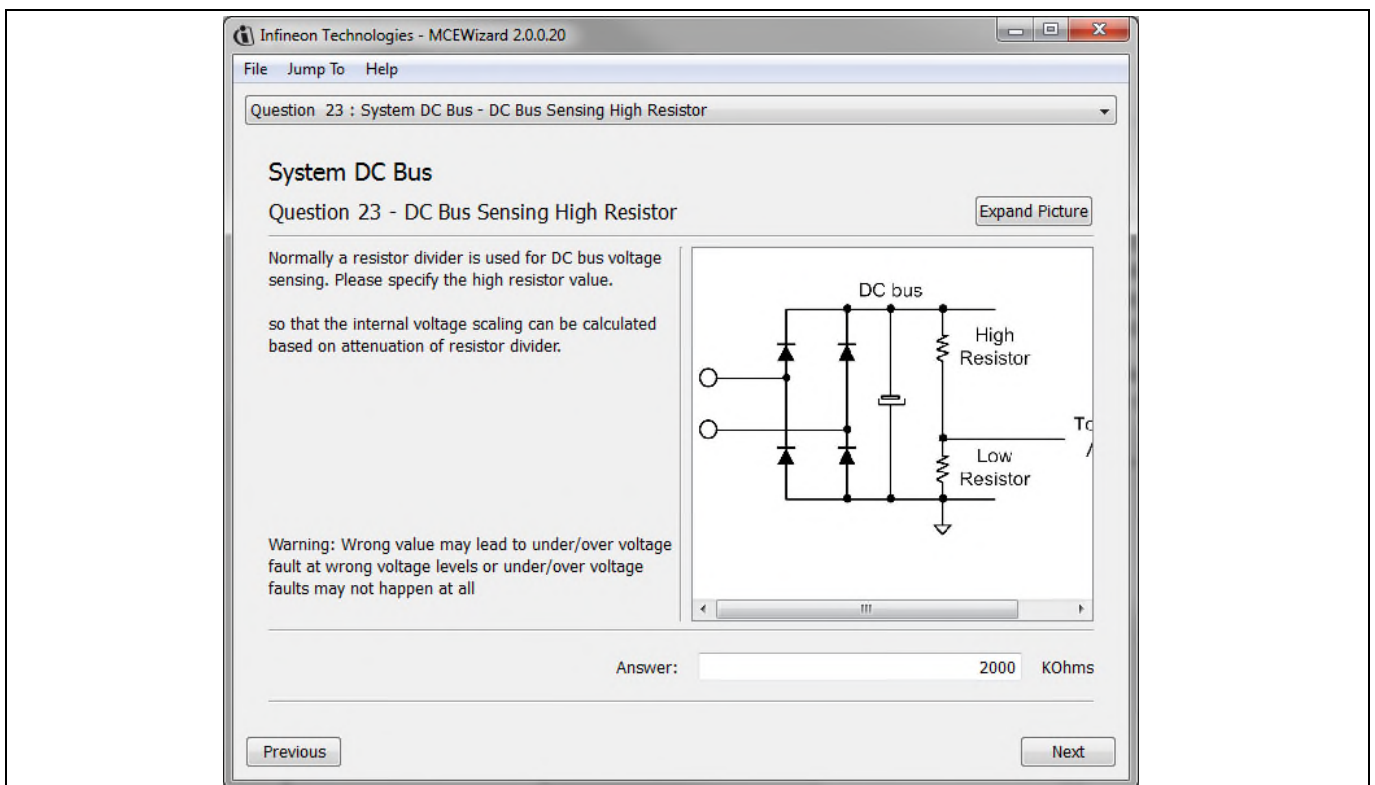

Figure 20 DC bus sensing configuration in MCEWizard

5.2.2 Motor External Current feedback configuration and calculation

The current input value is product of the shunt resistance in milliohms and gain of External current sense amplifier for EVAL-M3-102T as shown in Figure 21.

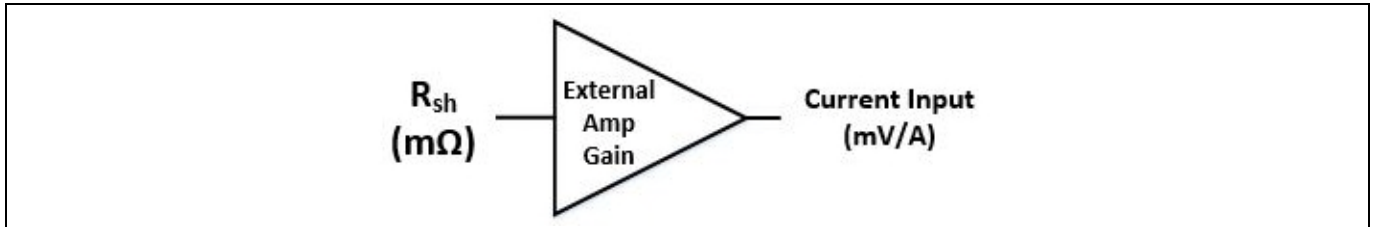

Figure 21 Current shunt feedback and sample timing for EVAL-M3-102T

The External Amplifier Gain circuit can be found in the schematics or User Manual for the control board (For example, EVAL-M3-102T see Figure 22).

Figure 22 depicts IU+ current feedback sensing circuitry on EVAL-M3-102T evaluation board. Please note that the default external amplification gain is less than 1 for current sense in this evaluation board.

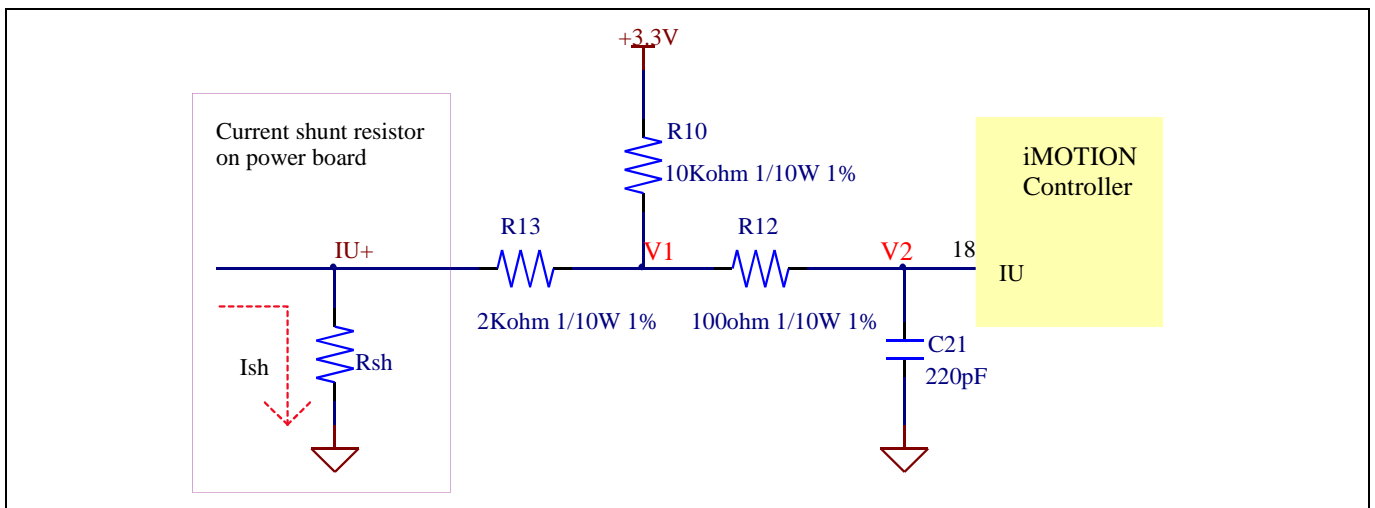

Figure 22 The part of Current feedback on the EVAL-M3-102T evaluation board

Based on the principle of Kirchhoff's voltage law,

$$V_2 \approx V_1 \approx (V_{DD} - I_{sh} * R_{sh}) * \frac{R_{13}}{R_{10} + R_{13}} + I_{sh} * R_{sh} = \frac{R_{13}}{R_{10} + R_{13}} V_{DD} + \frac{R_{10}}{R_{10} + R_{13}} R_{sh} * I_{sh}$$

$$Current\ input = \frac{R_{10}}{R_{10} + R_{13}} R_{sh} = \frac{5}{6} R_{sh}$$

Based on this calculation, the current input for the MADK combination of EVAL-M3-102T and EVAL-M3-CM615PN is 25 mV/A.

Please use same procedure to calculate the current input for other combinations of MADK boards and enter it into MCEWizard as shown in Figure 23.

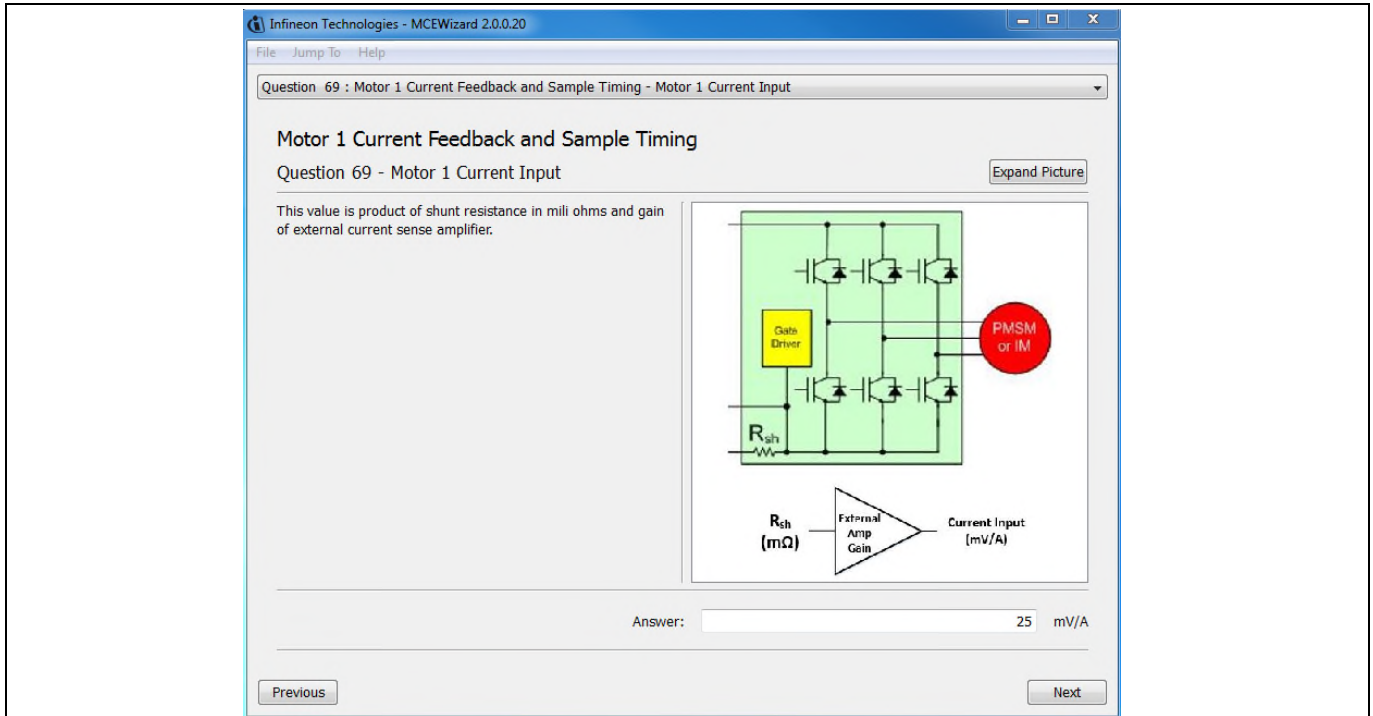

Figure 23 Current feedback configuration in MCEWizard for EVAL-M3-102T and EVAL-M3-CM615PN

5.2.3 Inverter Overcurrent protection and Motor Gatekill configuration

Figure 24 displays the overcurrent protection circuitry. The current sensing signal I_Shunt is connected to ITRIP via the resistor R32, and ITRIP is filtered through capacitor C21.

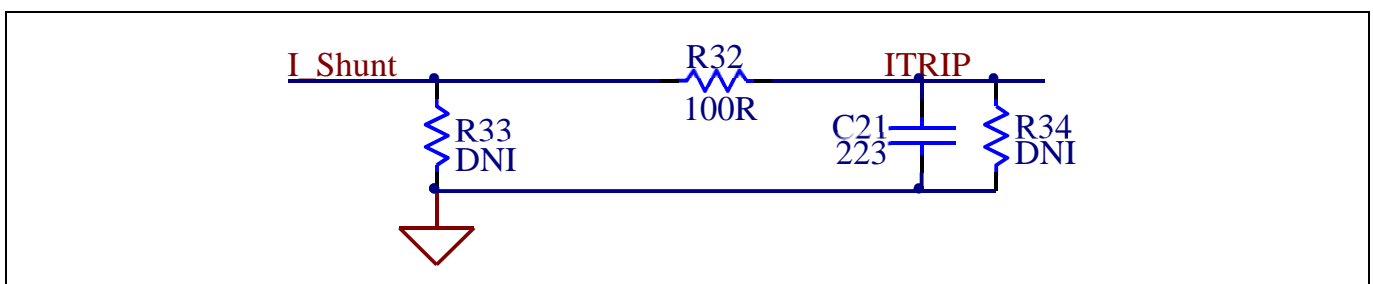

Figure 24 Overcurrent protection circuit on the Eval-M3-CM615PN evaluation board

The typical value of ITRIP positive going threshold $V_{IT,TH+}$ is 470mV. So the inverter output peak current is about 15.67A.

$$I_{trip} = \frac{V_{IT,TH+}}{R_{shunt}} = \frac{470mV}{30m\Omega} = 15.67A$$

If the motor peak current larger than the setting value I_{trip} for more than ITRIP Input filter time, VFO will be trigger low which is mean that the signal Gatekill is active. For iMOTION™ IMC1xx control IC, there are three types of Gatekill Input Source (as shown in Figure 25). For Gatekill Input Source configured Gatekill-Pin or Both, iMOTION™ control IC will stop the Motor when the signal GateKill is active.

But please note that, if select comparator for Gatekill Input Source, the external Gatekill signal will be not used. And the current sensing signal I_Shunt will be compared by the internal comparator with the “Gatekill Comparator Reference” value set in MCEWizard only.

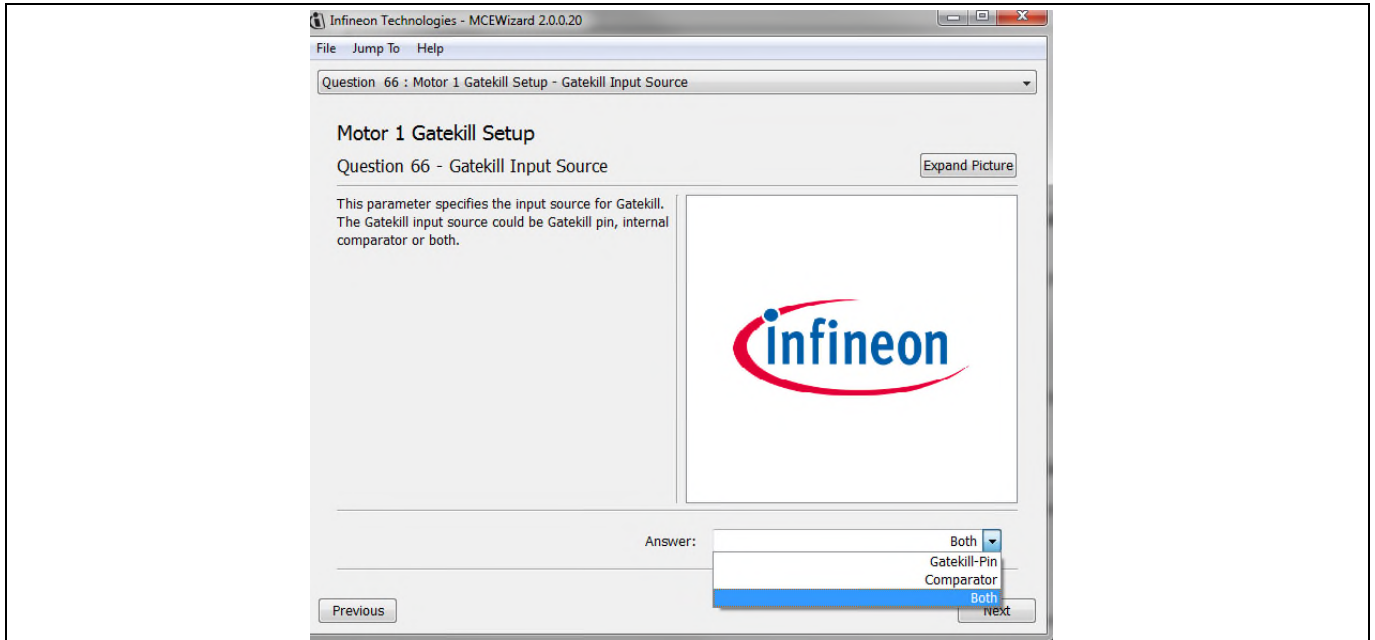

Figure 25 Gatekill configuration in MCEWizard for EVAL-M3-102T

5.3 Thermistor/NTC Characteristics and protection calculation

This board provides Thermistor/NTC output on pin 15 of the 30 pins connector J3. Temperatures can be calculated by resistor measurement.

5.3.1 CIPOS™ Internal NTC – Thermistor Characteristics

The thermistor characteristics for CIPOS™ mini IPM with build in NTC are listed as summarized in Table 8.

Table 8 CIPOS™ Internal NTC – Thermistor Characteristics

Description	Condition	Symbol	Value			Unit
			min	typ	max	
Resistor	T _{NTC} = 25°C	R _{NTC}	79.638	85.000	90.362	kΩ
Resistor	T _{NTC} = 50°C	R _{NTC}	28.400	29.972	31.545	kΩ
Resistor	T _{NTC} = 60°C	R _{NTC}	19.517	20.515	21.514	kΩ
Resistor	T _{NTC} = 70°C	R _{NTC}	13.670	14.315	14.960	kΩ
Resistor	T _{NTC} = 80°C	R _{NTC}	9.745	10.169	10.593	kΩ
Resistor	T _{NTC} = 90°C	R _{NTC}	7.062	7.345	7.628	kΩ
Resistor	T _{NTC} = 100°C	R _{NTC}	5.199	5.388	5.576	kΩ
Resistor	T _{NTC} = 110°C	R _{NTC}	3.856	4.009	4.163	kΩ
Resistor	T _{NTC} = 120°C	R _{NTC}	2.900	3.024	3.149	kΩ
Resistor	T _{NTC} = 125°C	R _{NTC}	2.527	2.639	2.751	kΩ
B-constant of NTC		B(25/100)		4092		K

The VFO pin of CIPOS™-Modules provides direct access to the NTC, which is referenced to VSS. An external pull-up resistor connected to +3.3V ensures that the resulting voltage can be directly connected to the microcontroller.

Figure 26 depicts the CIPOS™ internal circuit at pin VFO. An external pull-up resistor is required to bias the NTC.

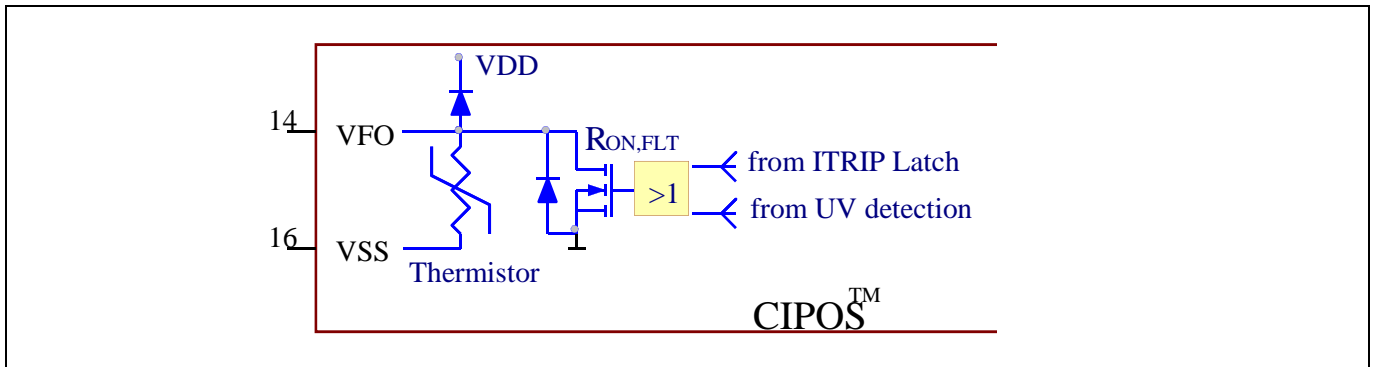

Figure 26 Internal circuit at pin VFO for CIPOS™ IPM IFCM15P60GD

5.3.2 Overtemperature Hardware Protection Circuit

The VFO pin not only provides direct access to the NTC, but also indicates a module failure in case of under voltage at pin VDD or in case of triggered overcurrent detection at ITRIP. In this evaluation design kits Eval-M3-CM615PN and Eval-M3-102T, the VFO pin is directly connected to the Gatekill pin for controller IC IMC102T.

But for iMOTION™ 100series control board, the maximum input low voltage of Gatekill for IRMCF1xx is 0.8V. And NTC thermal resistor is about 3.0 kΩ at 120°C. The resistors R35 and R36 for the power board Eval-M3-CM615PN are chosen properly to make sure the voltage of VFO is 0.8V at 120°C. And then the Gatekill will ask the microcontroller to stop generating PWM pulses if the temperature of NTC continues to rise.

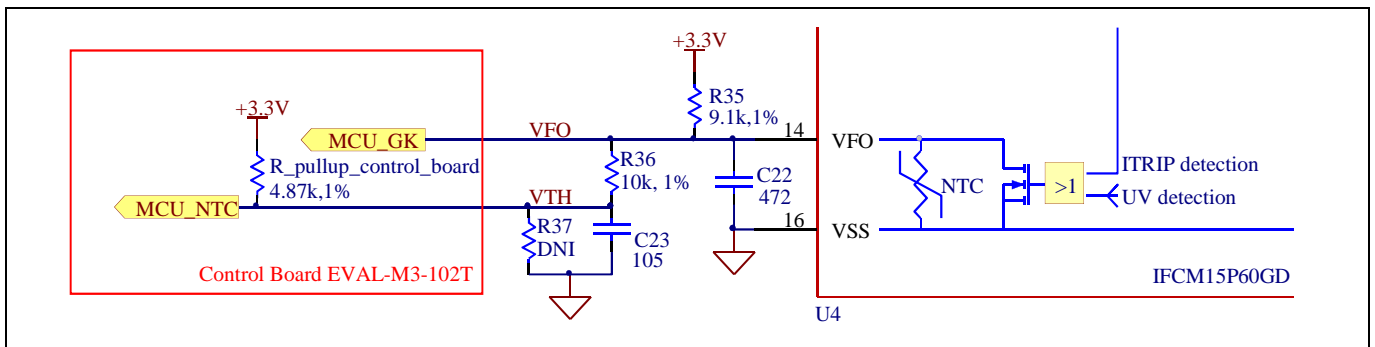

Figure 27 Overtemperature protection circuit schematic for Eval-M3-CM615PN and Eval-M3-102T

5.3.3 NTC shutdown value calculation and configuration

External NTC Temperature shutdown value can be calculated as shown below and configured in MCEWizard as shown in Figure 28. For pull-up resistor on evaluation control board, please refer to the control board's User Manual. For example, for EVAL-M3-102T, the pull-up resistor on the control board is 4.87kΩ. The value of resistors R35 and R36 on EVAL-M3-CM615PN are 9.1 kΩ and 10 kΩ (see Figure 27). The typical value of R_{NTC} at 100°C is 5.388kΩ for IPM IFCM15P60GD which is used in EVAL-M3-CM615PN.

$$V_{FO} = \frac{R_{NTC@setting\ temperature}}{R_{NTC@setting\ temperature} + \frac{R_{35} * (R_{36} + R_{pull-up\ on\ Control\ board})}{R_{35} + R_{36} + R_{pull-up\ on\ Control\ board}}} V_{DD}$$

$$V_{shut\ down} = \frac{R_{36} * V_{DD} + R_{pull-up\ on\ Control\ board} * V_{FO}}{R_{36} + R_{pull-up\ on\ Control\ board}}$$

If the setting temperature is 100°C, the shutdown value should be 2.75V. If the setting temperature is 85°C, the shutdown value should be 2.87V.

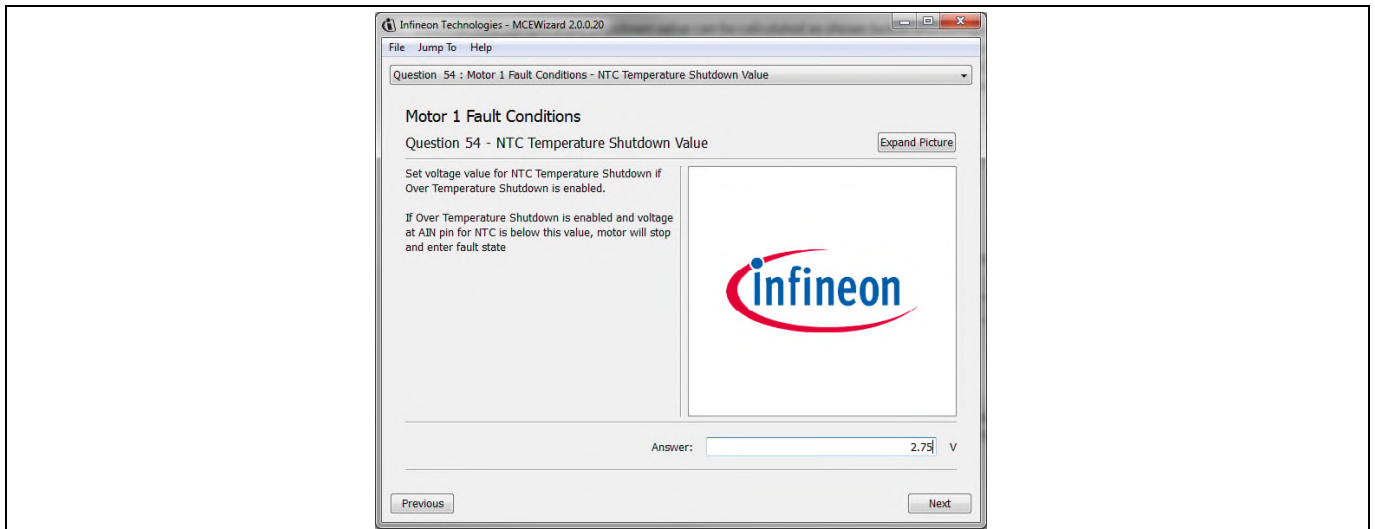

Figure 28 External temperature sense input configuration in MCEWizard

5.4 Auxiliary power supply

Figure 29 depicts the schematic of the auxiliary power supply for the Eval-M3-CM615PN board. The circuit includes a LNK306 that is used to generate 15 V directly from the DC bus. V_{CC} is connected to the gate drivers inside the CIPOST™ IPM.

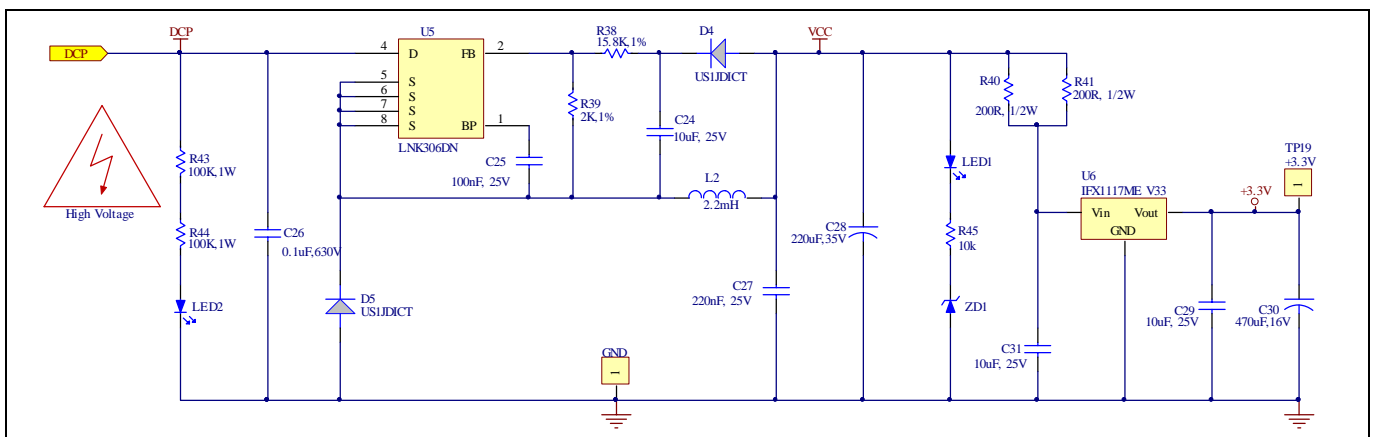

Figure 29 Power supply section of the Eval-M3-CM615PN evaluation board

The linear voltage regulator IFX1117ME V33 generates 3.3 V from 15 V power supply V_{CC}. The 3.3 V power supply is used in the PFC overcurrent comparator circuit and overtemperature hardware protection circuit. Both V_{CC} and 3.3 V are also present on the 30 pins iMOTION™ MADK-M3 interface connector J3 to power circuitry on the control board.

5.5 Schematics for EVAL-M3- CM615PN

The PFC section schematic for EVAL-M3- CM615PN is provided in Figure 30.

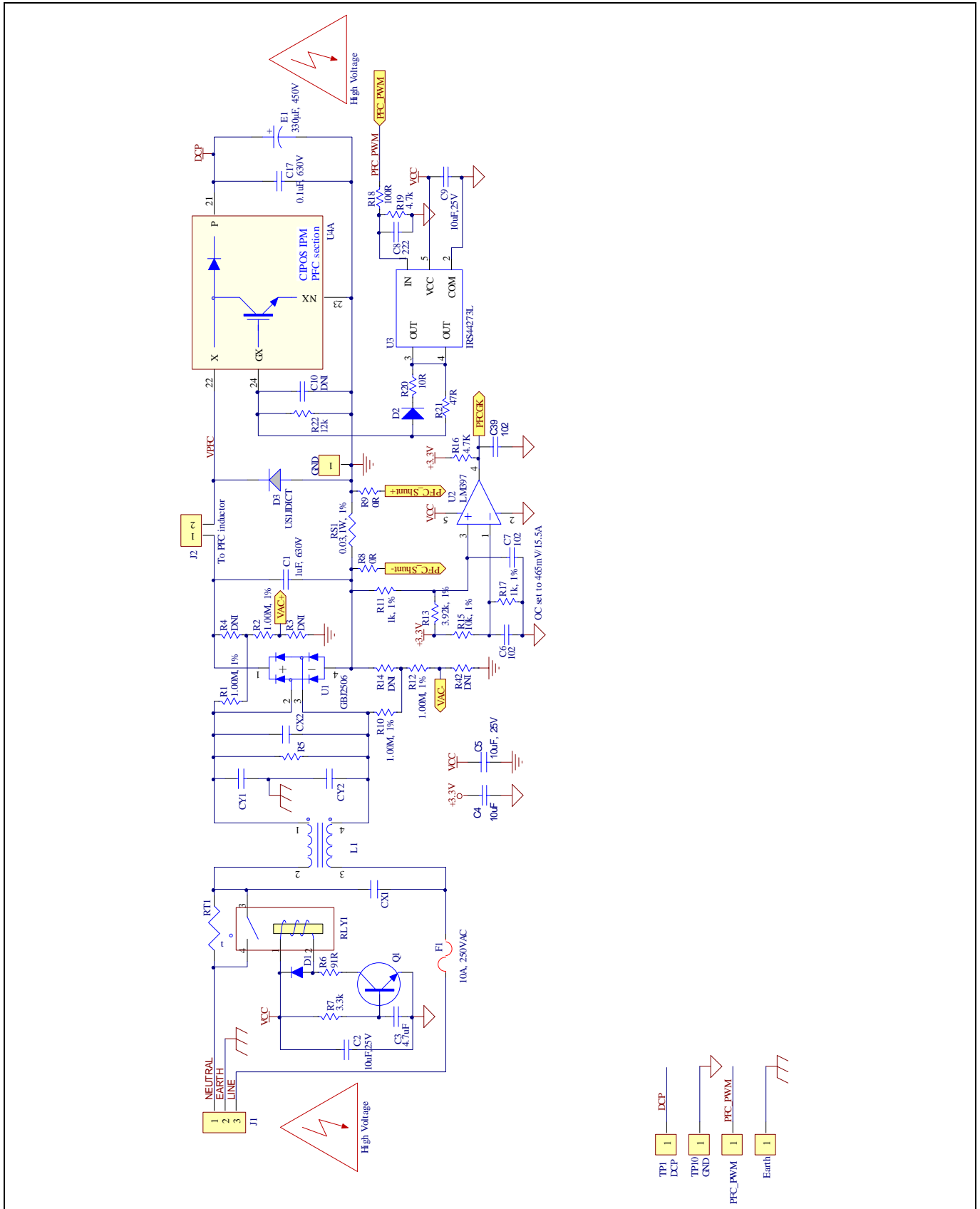

Figure 30 PFC Section Schematics for EVAL-M3- CM615PN

The Inverter section schematic for EVAL-M3- CM615PN is provided in Figure 31.

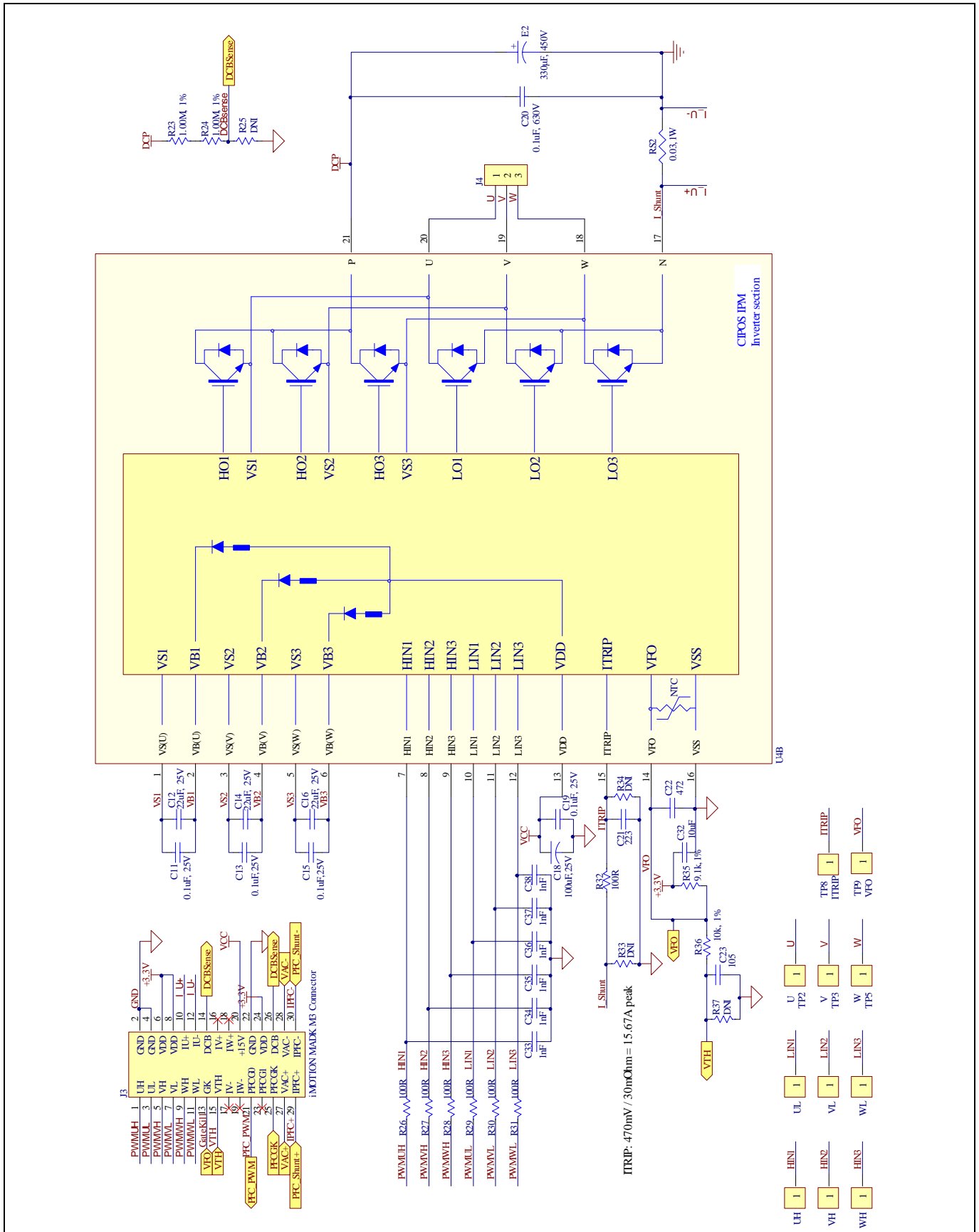

Figure 31 Inverter Section Schematics for EVAL-M3- CM615PN

The Auxiliary Power Supply setion schematic for EVAL-M3- CM615PN is provided in Figure 32.

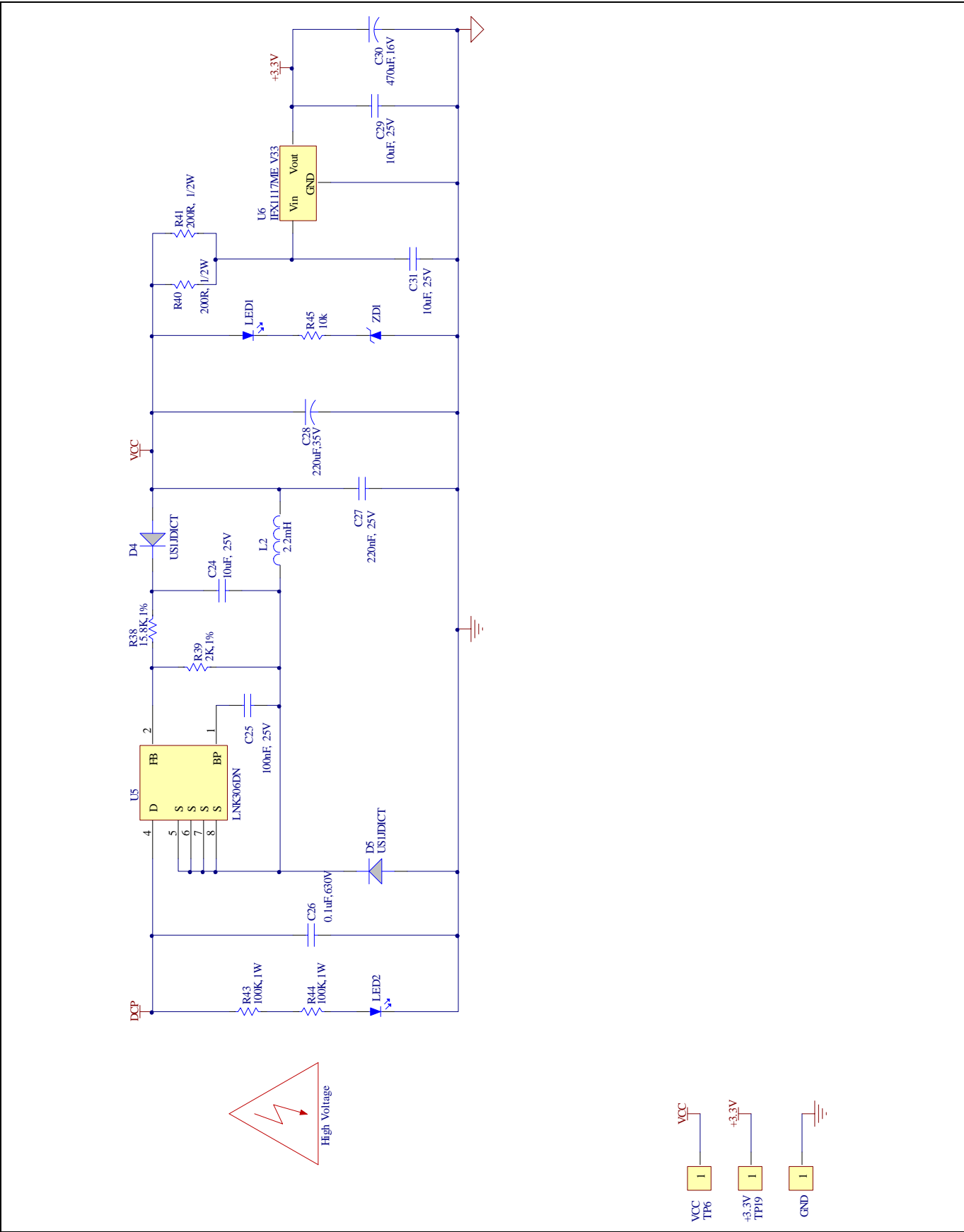

Figure 32 Auxiliary Power Supply Section Schematics for EVAL-M3- CM615PN

5.6 PCB Layout for EVAL-M3- CM615PN

The layout of this board can be used for different voltage or power classes. The PCB has two electrical layers with 35µm copper by default and its size is 120 mm × 120 mm. The PCB board thickness is 1.6mm. Get in contact with our technical support team to get more detailed information and the latest Gerber-files.

Figure 33 illustrates the top assembly print of the evaluation board.

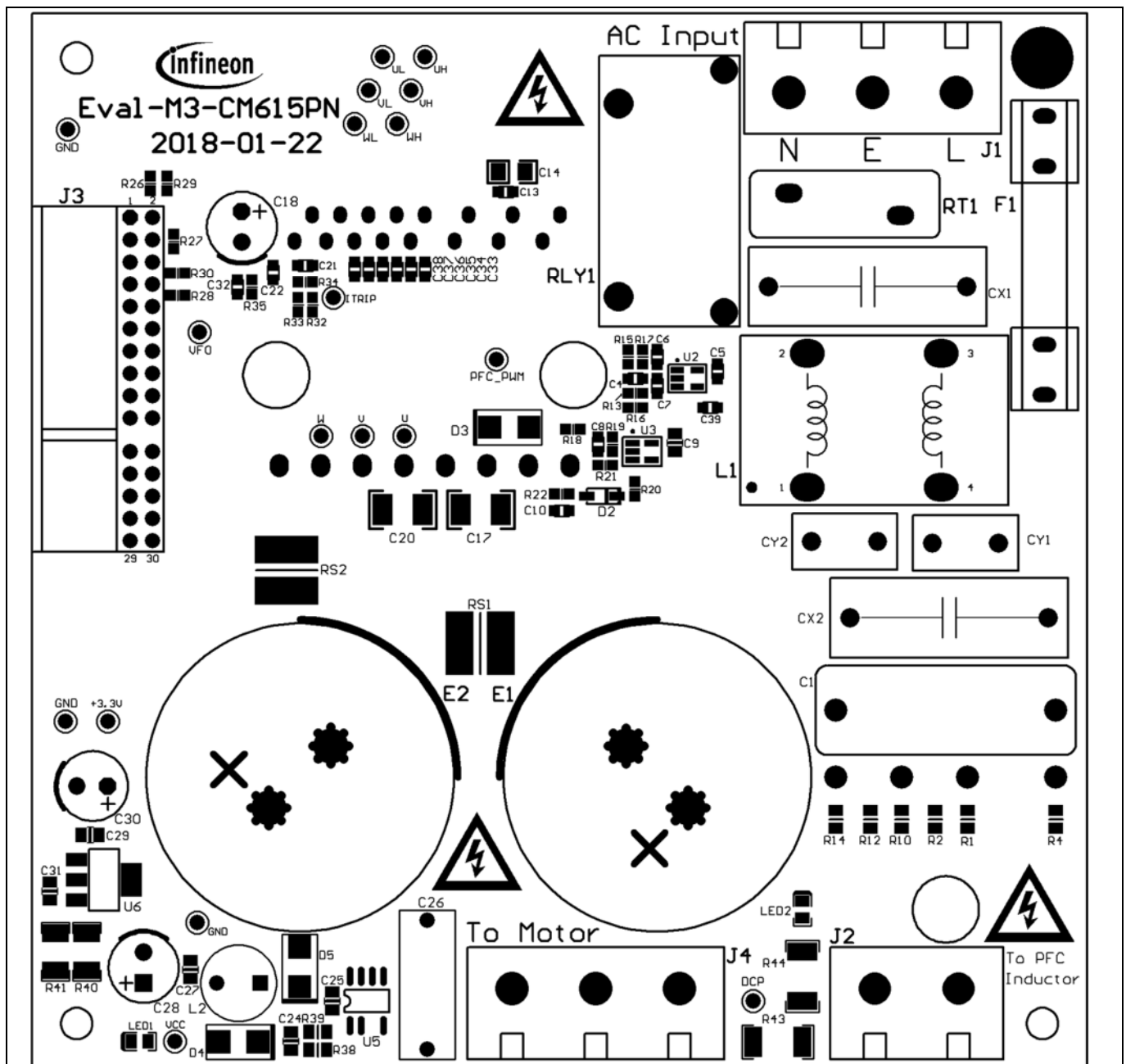

Figure 33 Top assembly print of the Eval-M3-CM615PN evaluation board

Figure 34 depicts the bottom assembly print of the evaluation board.

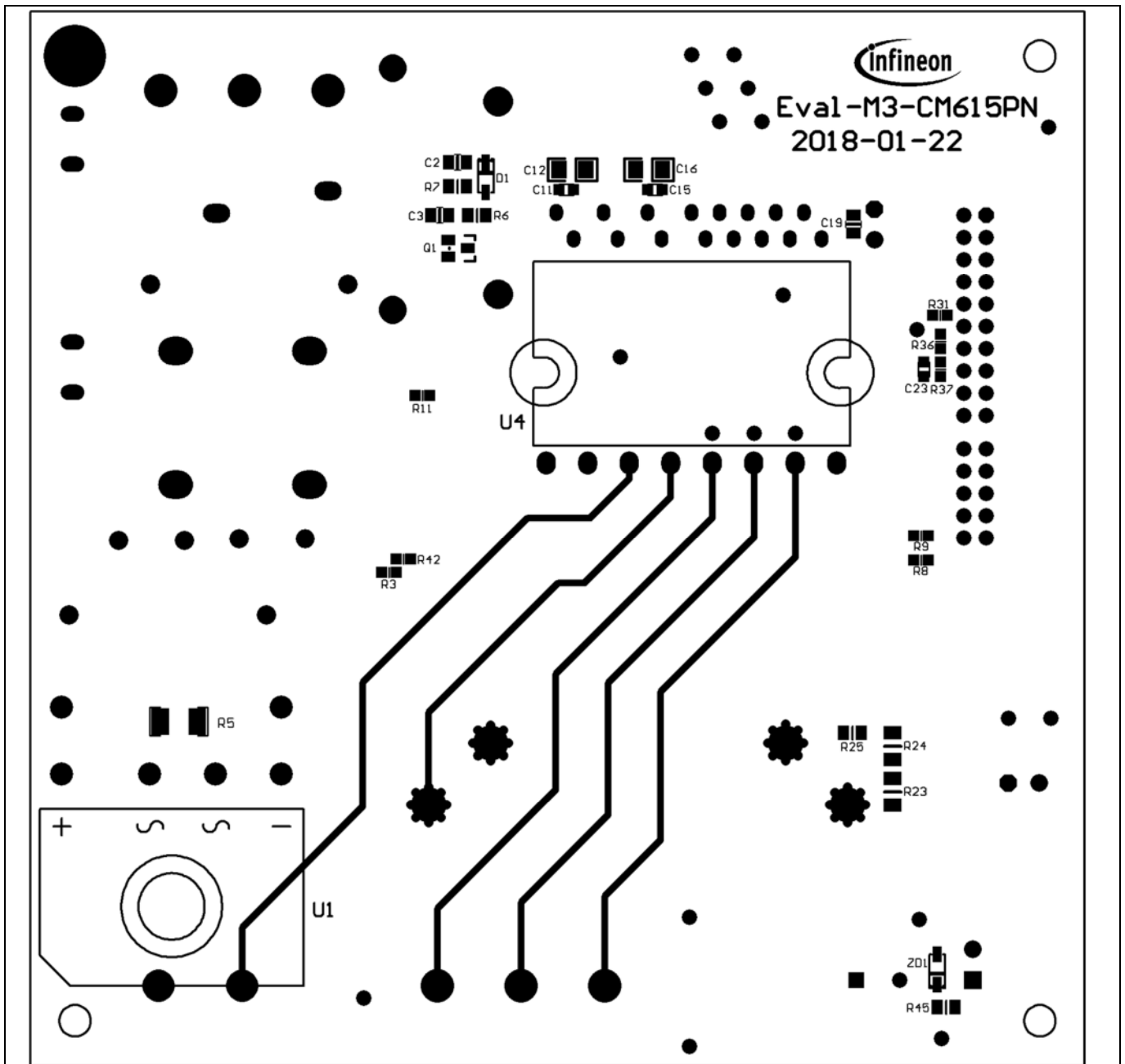

Figure 34 Bottom assembly print of the Eval-M3-CM615PN evaluation board

The top layer routing of the PCB is provided in Figure 35.

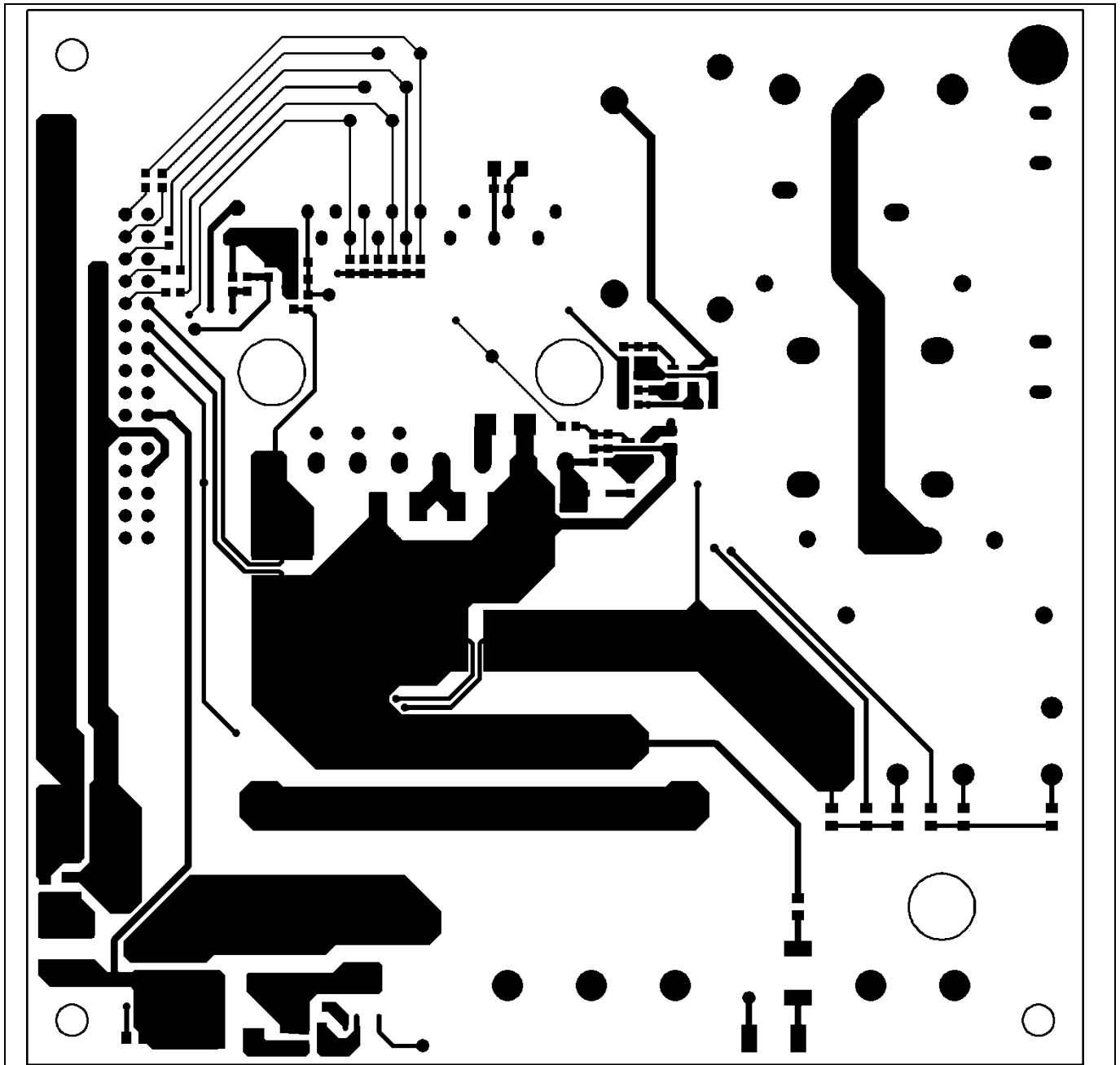

Figure 35 Top layer routing of the Eval-M3-CM615PN

Figure 36 illustrates the bottom layer routing of the PCB.

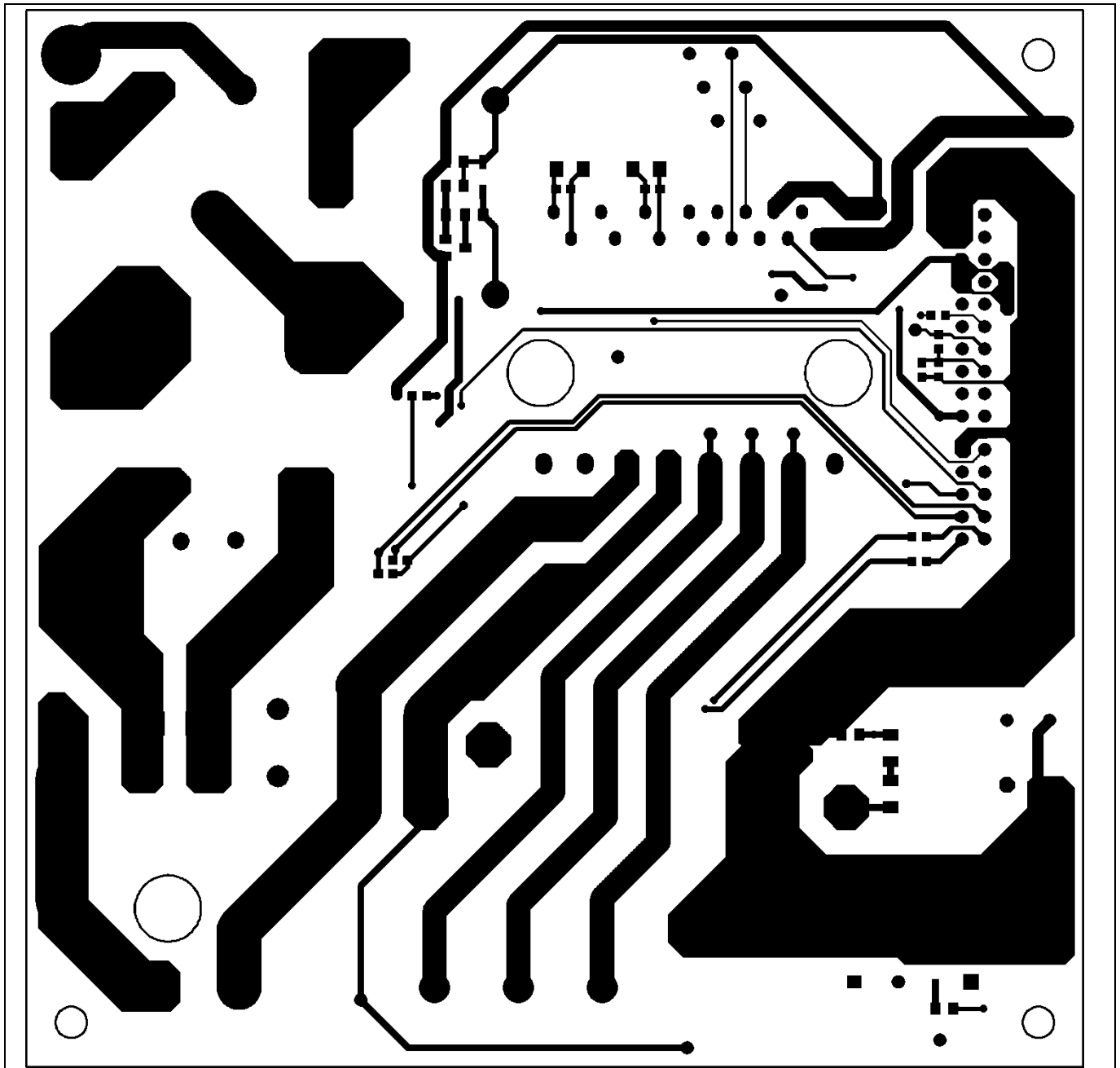

Figure 36 Bottom layer routing of the Eval-M3-CM615PN

Bill of material

6 Bill of material

Table 9 provides the complete bill of materials for the Eval-M3-CM615PN.

Table 9 Bill of materials

No.	Qty	Part description	Designator	Part number	Manufacturer
1	1	CAP FILM 1 μ F 5% 630VDC RADIAL	C1	ECW-F6105JL	Panasonic Electronic
2	2	CAP CER 10 μ F 25V X5R 0805	C2, C9	C2012X5R1E106M12 5AB	TDK Corporation
3	1	CAP CER 4.7 μ F 10V X7R 0805	C3	885012207025	Würth Electronics Inc.
4	2	CAP CER 10 μ F 10V X5R 0603	C4, C32	CC0603KRX5R6BB10 6	Yageo
5	1	CAP CER 10 μ F 25V X5R 0603	C5	C1608X5R1E106M08 0AC	TDK Corporation
6	3	CAP CER 1000pF 10V X7R 0603	C6, C7, C39	885012206008	Würth Electronics Inc.
7	1	CAP CER 2200pF 10V X7R 0603	C8	885012206010	Würth Electronics Inc.
8	1	CAP CER 0.1 μ F 25V X7R 0603	C11	885012206071	Würth Electronics Inc.
9	3	CAP CER 22 μ F 25V X5R 1206	C12, C14, C16	C3216X5R1E226M16 0AB	TDK Corporation
10	2	CAP CER 0.1 μ F 25V X7R 0603	C13, C15	885012206071	Würth Electronics Inc.
11	2	CAP CER 0.1 μ F 630V X7R 1812	C17, C20	C4532X7R2J104M23 0KA	TDK Corporation
12	1	CAP ALUM 100 μ F 25V RADIAL	C18	UTT1E101MPD1TD	Nichicon
13	1	CAP CER 0.1 μ F 25V X7R 0805	C19	885012207072	Würth Electronics Inc.
14	1	CAP CER 0.022 μ F 10V X7R 0603	C21	885012206016	Würth Electronics Inc.
15	1	CAP CER 4700pF 10V X7R 0603	C22	885012206012	Würth Electronics Inc.
16	1	CAP CER 1 μ F 10V X7R 0603	C23	885012206026	Würth Electronics Inc.
17	3	CAP CER 10 μ F 25V X5R 0805	C24, C29, C31	C2012X5R1E106M12 5AB	TDK Corporation
18	1	CAP CER 0.1 μ F 25V X7R 0805	C25	885012207072	Würth Electronics Inc.
19	1	CAP CER 0.1 μ F 630V X7R 1812	C26	C4532X7R2J104K23 0KA	TDK Corporation
20	1	CAP CER 0.22 μ F 25V X7R 0805	C27	885012207074	Würth Electronics Inc.
21	1	CAP ALUM 220 μ F 35V RADIAL	C28	35ZLS220MEFC8X11. 5	Rubycon
22	1	CAP ALUM 470 μ F 16V RADIAL	C30	16ZLH470MEFC8X11 .5	Rubycon
23	6	CAP CER 1000pF 10V X7R 0603	C33, C34, C35, C36, C37, C38	885012206008	Würth Electronics Inc.
24	2	CAP FILM 0.47 μ F 10% 275VAC RADIAL	CX1, CX2	MKP275VAC474PF	JIMSON
25	2	CAP CER 3300pF 440VAC Y5U	CY1, CY2	ECK-ATS332ME	Panasonic Electronic

Bill of material

No.	Qty	Part description	Designator	Part number	Manufacturer
		RADIAL			Components
26	1	Diode GEN PURP 100V 300mA SOD123	D1	1N4148W-7-F	Diodes Incorporated
27	1	Diode GEN PURP 100V 300mA SOD123	D2	1N4148W-7-F	Diodes Incorporated
28	3	Diode Standard 600V 1A Surface Mount SMA	D3, D4, D5	US1J-13-F	Diodes Incorporated
29	2	CAP ALUM 330μF 20% 450V SNAP	E1, E2	EET-UQ2W331EA	Panasonic Electronic
30	1	FUSE CERAMIC 10A 250V Φ6X30	F1	RO58 /BS1362-10A	Zhenghao Fuse Co.
31	2	CONN TERM BLOCK 3POS 9.52MM PCB	J1, J4	1714984	Phoenix Contact
32	1	CONN TERM BLOCK 2POS 9.52MM PCB	J2	1714971	Phoenix Contact
33	1	HEADER 20POS SCKT R/A DL 2.54 MM & HEADER 10POS SCKT R/A DL 2.54 MM	J3	613020243121 & 613010243121	Würth Electronics Inc.
34	1	CONN RCPT .100" 10 PS DL R/A GOLD	L1	JWMILLER_8108	Bourns Inc.
35	1	FIXED IND 2.2mH THROUGH HOLE	L2	RLB0914-222KL	Bourns Inc.
36	1	LED GREEN CLEAR 0805 SMD	LED1	150080GS75000	Würth Electronics Inc.
37	1	LED RED CLEAR 0805 SMD	LED2	150080RS75000	Würth Electronics Inc.
38	1	TRANS NPN 100V 1A SOT23-3	Q1	FMMT493TA	Diodes Incorporated
39	4	RES SMD 1MΩ 1% 1/8W 0805	R1, R2, R10, R12	RC0805FR-071ML	Yageo
40	1	RES SMD 1MΩ 5% 3/4W 2010	R5	RC2010JK-071ML	Yageo
41	1	RES SMD 91 Ω 5% 1/8W 0805	R6	RC0805JR-0791RL	Yageo
42	1	RES SMD 3.3kΩ 5% 1/8W 0805	R7	RC0805JR-073K3L	Yageo
43	2	RES SMD 0 Ω JUMPER 1/10W 0603	R8, R9	RC0603FR-070RL	Yageo
44	2	RES SMD 1kΩ 1% 1/10W 0603	R11, R17	RC0603FR-071KL	Yageo
45	1	RES SMD 3.92kΩ 1% 1/10W 0603	R13	RC0603FR-073K92L	Yageo
46	2	RES SMD 10kΩ 1% 1/10W 0603	R15, R36	RC0603FR-0710KL	Yageo
47	2	RES SMD 4.7kΩ 5% 1/10W 0603	R16, R19	RC0603JR-074K7L	Yageo
48	8	RES SMD 100 Ω 5% 1/10W 0603	R18, R26, R27, R28, R29, R30, R31, R32	RC0603JR-07100RL	Yageo
49	1	RES SMD 10 Ω 5% 1/10W 0603	R20	RC0603JR-0710RL	Yageo
50	1	RES SMD 47 Ω 5% 1/10W 0603	R21	RC0603JR-0747RL	Yageo
51	1	RES SMD 12kΩ 5% 1/10W 0603	R22	RC0603JR-0712KL	Yageo
52	2	RES SMD 1MΩ 1% 1/4W 1206	R23, R24	RC1206FR-071ML	Yageo
53	1	RES SMD 9.1kΩ 1% 1/10W 0603	R35	RC0603FR-079K1L	Yageo
54	1	RES SMD 15.8kΩ 1% 1/8W 0805	R38	RC0805FR-0715K8L	Yageo

Bill of material

No.	Qty	Part description	Designator	Part number	Manufacturer
55	1	RES SMD 2kΩ 1% 1/8W 0805	R39	RC0805FR-072KL	Yageo
56	2	RES SMD 200 Ω 5% 3/4W 2010	R40, R41	RC2010JK-07200RL	Yageo
57	2	RES SMD 100kΩ 5% 1W 2512	R43, R44	RC2512JK-07100KL	Yageo
58	1	RES SMD 10kΩ 5% 1/8W 0805	R45	RC0805JR-0710KL	Yageo
59	1	RELAY GEN PURPOSE SPST 20A	RLY1	G4A-1A-PE DC12	Omron Electronics Inc-EMC Div
60	1	RES SMD 0.03Ω 1% 2W 2512 wide	RS1	FC4L64R030FER	Ohmite
61	1	RES SMD 0.03Ω 1% 2W 2512 wide	RS2	FC4L64R030FER	Ohmite
62	1	NTC thermistors for inrush	RT1	NTC5D-20	Veteng Electronic
63	1	RECT BRIDGE GPP 600V 25A GBJ	U1	GBJ2506-F	Diodes Incorporated
64	1	IC COMPARATOR VOLT SGL SOT23-5	U2	LM397MF/NOPB	Texas Instruments
65	1	IC DRIVER LOW SIDE 1.5A SOT23-5	U3	IRS44273LTRPBF	Infineon Technologies
66	1	IFPS MODULES 24MDIP	U4	IFCM15P60GD XKMA 1	Infineon Technologies
67	1	IC OFFLINE SWIT OCP 8SOIC	U5	LNK306DN	Power Integrations
68	1	IC REG LINEAR 3.3V 1A SOT223-4	U6	IFX1117MEV33HTMA 1	Infineon Technologies
69	1	DIODE ZENER 10V 500mW SOD123	ZD1	BZT52C10-7-F	Diodes Incorporated

7 Reference

- [1] Datasheet of Infineon CIPOS™ mini IPM IFCM15P60GD
- [2] Application Note AN2016-10 CIPOS Mini Technical Description
- [3] AN2018-02 EVAL-M3-102T User manual
- [4] MCEWizard User Guide
- [5] MCEDesigner User Guide

*Note: All listed reference materials are available for download on Infineon's website www.infineon.com/.
All the iMOTION MADK evaluation board's User Manuals are available at www.infineon.com/MADK
All the CIPOS™ IPM's Datasheets and documents are available at www.infineon.com/IPM.*

Revision history

Document version	Date of release	Description of changes
1.0	2017-07-01	First release
1.1	2018-03-09	Moved to latest template plus iMOTION2.0 configuration modifications

Trademarks

All referenced product or service names and trademarks are the property of their respective owners.

Edition 2018-03-09

Published by

Infineon Technologies AG

81726 Munich, Germany

© 2018 Infineon Technologies AG.

All Rights Reserved.

Do you have a question about this document?

Email: erratum@infineon.com

Document reference

AN2017-15

IMPORTANT NOTICE

The information contained in this application note is given as a hint for the implementation of the product only and shall in no event be regarded as a description or warranty of a certain functionality, condition or quality of the product. Before implementation of the product, the recipient of this application note must verify any function and other technical information given herein in the real application. Infineon Technologies hereby disclaims any and all warranties and liabilities of any kind (including without limitation warranties of non-infringement of intellectual property rights of any third party) with respect to any and all information given in this application note.

The data contained in this document is exclusively intended for technically trained staff. It is the responsibility of customer's technical departments to evaluate the suitability of the product for the intended application and the completeness of the product information given in this document with respect to such application.

For further information on the product, technology, delivery terms and conditions and prices please contact your nearest Infineon Technologies office (www.infineon.com).

WARNINGS

Due to technical requirements products may contain dangerous substances. For information on the types in question please contact your nearest Infineon Technologies office.

Except as otherwise explicitly approved by Infineon Technologies in a written document signed by authorized representatives of Infineon Technologies, Infineon Technologies' products may not be used in any applications where a failure of the product or any consequences of the use thereof can reasonably be expected to result in personal injury.



Компания «ЭлектроПласт» предлагает заключение долгосрочных отношений при поставках импортных электронных компонентов на взаимовыгодных условиях!

Наши преимущества:

- Оперативные поставки широкого спектра электронных компонентов отечественного и импортного производства напрямую от производителей и с крупнейших мировых складов;
- Поставка более 17-ти миллионов наименований электронных компонентов;
- Поставка сложных, дефицитных, либо снятых с производства позиций;
- Оперативные сроки поставки под заказ (от 5 рабочих дней);
- Экспресс доставка в любую точку России;
- Техническая поддержка проекта, помощь в подборе аналогов, поставка прототипов;
- Система менеджмента качества сертифицирована по Международному стандарту ISO 9001;
- Лицензия ФСБ на осуществление работ с использованием сведений, составляющих государственную тайну;
- Поставка специализированных компонентов (Xilinx, Altera, Analog Devices, Intersil, Interpoint, Microsemi, Aeroflex, Peregrine, Syfer, Eurofarad, Texas Instrument, Miteq, Cobham, E2V, MA-COM, Hittite, Mini-Circuits, General Dynamics и др.);

Помимо этого, одним из направлений компании «ЭлектроПласт» является направление «Источники питания». Мы предлагаем Вам помощь Конструкторского отдела:

- Подбор оптимального решения, техническое обоснование при выборе компонента;
- Подбор аналогов;
- Консультации по применению компонента;
- Поставка образцов и прототипов;
- Техническая поддержка проекта;
- Защита от снятия компонента с производства.



Как с нами связаться

Телефон: 8 (812) 309 58 32 (многоканальный)

Факс: 8 (812) 320-02-42

Электронная почта: org@eplast1.ru

Адрес: 198099, г. Санкт-Петербург, ул. Калинина, дом 2, корпус 4, литера А.