



### PRODUCT OVERVIEW

The D2U5T-H3-5000-380-HU3C is a High Efficiency 3500/5000 watt, power factor corrected three phase power supply for 230/480Vac lines with a 380V high voltage (HVDC) main output and a selectable 5V or 3.3V (20W) standby. The unit is provided with Droop Sharing and up to three (3) power modules may be operated in parallel.

The power module is hot pluggable. The module is able to protect and recover from over temperature faults, and has status LEDs on the front panel and additional logic and PMBus status signals.

Their 2U package and >16.5W/cubic inch power density make them ideal for delivering reliable, efficient power to servers, workstations, storage systems and other 380V HVDC distributed power systems. An optional power shelf is also available that accommodates up to three (3) power modules.

### FEATURES

- 5KW (480Vac), 3.5KW (230Vac) Output Power
- Very High Efficiency; 95.4% @ 50% FL
- 380V High Voltage Main Output
- 3.3V or 5V Standby Output
- Nominal Dim's: 5.1"(W) x 18"(L) x 3.3" (2U)
- 16.5 watts/cubic inch power density
- $N+1$  redundant (including hot docking)
- Droop sharing on Main Output
- Over-voltage, over-current, over-temperature protections
- Internal cooling fan
- I<sup>2</sup>C Bus Interface with status indicators
- Optional 19" power shelf
- RoHS compliant
- Two-year warranty



Available now at:

[www.murata-ps.com/en/3d/acdc.html](http://www.murata-ps.com/en/3d/acdc.html)



Test Certificate and Test Report



### ORDERING GUIDE

Model Number	Power	Main Output	Standby Output	Airflow
D2U5T-H3-5000-380-HU3C	5000W	380V	3.3V or 5V (Selectable)	Front to Back

### INPUT CHARACTERISTICS

Parameter	Conditions	Min	Typ	Max	Units
Input Frequency		47	50/60	63	Hz
Input Voltage Operating Range	Range 1	180		264	Vac
	Range 2	320		528	Vac
Turn-on Voltage (Ramp-up)	Range 1		170		Vac
	Range 2		280		Vac
Turn-off Voltage (Ramp-down)	Range 1		150		Vac
	Range 2		260		Vac
Maximum Input Current			13		Arms
Inrush Current	Cold Start			30	Apk
Power Factor, Range 1, 60Hz	600W, 230 Vac		0.992		
	1750W (50%), 230 Vac		0.998		
	3500W (100%), 230 Vac		0.998		
Power Factor, Range 2, 60Hz	600W, 480 Vac		0.910		
	2500W (50%), 480 Vac		0.995		
	5000W (100%), 480 Vac		0.995		

### OVERALL CHARACTERISTICS

Parameter	Conditions	Min	Typ	Max	Units
Output Power	Range 1			3500	W
	Range 2			5000	
Efficiency, Range 1	700W (20%), 230Vac		89.5		%
	1750W (50%), 230Vac		93.6		
	3500W (100%), 230Vac		94.2		
Efficiency, Range 2	500W (20%), 230Vac		92.6		%
	2500W (50%), 230Vac		95.4		
	5000W (100%), 230Vac		95.4		

The following curves represent the achieved efficiency performance for the D2U5T-H3-5000-380-Hu3C product compared against a recognized industry standard for efficiency rating.

The D2U5T-H3-5000-380-HU3C offers performance in excess of the industry standard limit as a required percentage of loading.

Test methodology as per Ecova Generalized Test Protocol for Calculating the Energy Efficiency of Internal AC-DC and DC-DC Power Supplies Revision 6.7

### EFFICIENCY PERFORMANCE CURVES

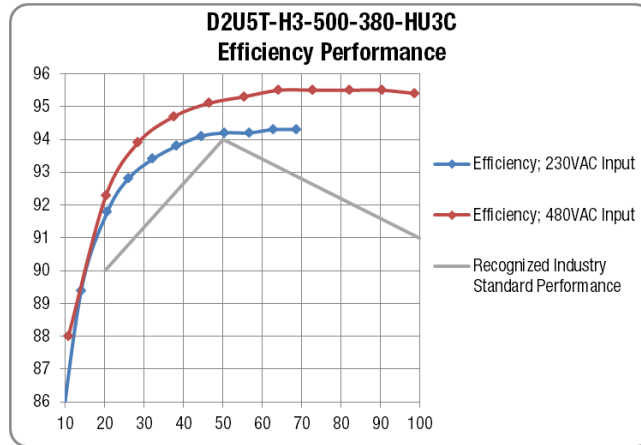

### OUTPUT VOLTAGE CHARACTERISTICS

Output	Parameter	Conditions	Min	Typ	Max	Units
380V	Output Current	Range 1	0		9.2	A
		Range 2	0		13.34	A
	Voltage Set Point	@4.6A Range 1		380		Vdc
		@6.67A Range 2		380		Vdc
	Voltage Droop	Min to Max Current, Range 1			7	
		Min to Max Current, Range 2			11	
	Line Regulation				0.1	%
Ripple Voltage & Noise <sup>1</sup>				1	Vp-p	
3.3VSB	Load Capacitance		100		1000	μF
	Voltage Set Point			3.3		Vdc
	Line and Load Regulation		3.14		3.46	
	Ripple Voltage & Noise <sup>2</sup>	20MHz Bandwidth			75	mVp-p
	Output Current		0		6	A
5VSB	Load Capacitance		20		1000	μF
	Voltage Set Point			5		Vdc
	Line and Load Regulation		4.76		5.24	
	Ripple Voltage & Noise <sup>2</sup>	20MHz Bandwidth			100	mVp-p
	Output Current		0		4	A
Load Capacitance		20		1000	μF	

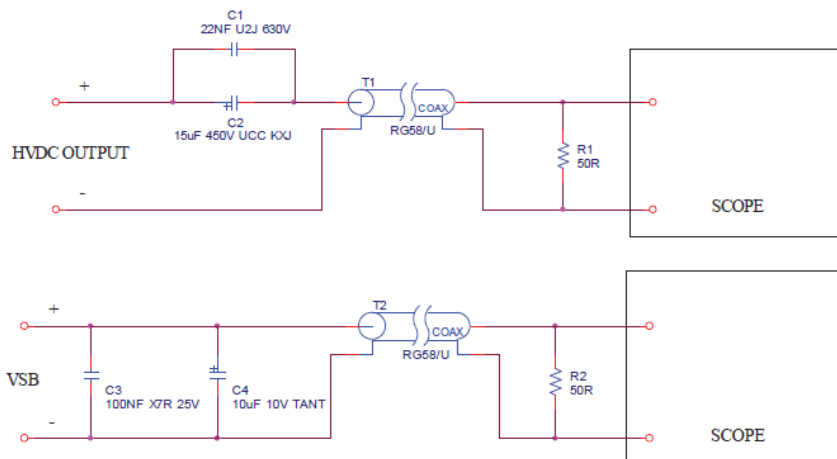

<sup>1</sup> Ripple and noise are measured with 22nF (U2J 630V) ceramic + 15 μF (UCC KXJ) of electrolytic de-coupling capacitors at the output connector load side. A short coaxial cable with 50ohm scope termination is used.

<sup>2</sup> Ripple and noise are measured with 0.1 uF of ceramic capacitance and 10 uF of tantalum capacitance across the power supply outputs at the output connector load side. A short coaxial cable with 50ohm scope termination is used.

### OUTPUT CHARACTERISTICS

Parameter	Conditions	Min	Typ	Max	Units
Startup Time	AC ramp up			3	s
Transient Response	380V, 50-100% load step, 0.1A/ $\mu$ s di/dt		15		Vp-p
	5VSB, 50-100% load step, 1A/ $\mu$ s di/dt		250		mVp-p
	3.3VSB, 50-100% load step, 1A/ $\mu$ s di/dt		165		mVp-p
Current sharing accuracy (up to 3 in parallel)	380V @100% load			+/-10	%
Hot Swap Transients	All outputs within regulation				
Holdup Time	380V @100% load	25			ms
	VSB @100% Load	500			

### GENERAL CHARACTERISTICS

Parameter	Conditions	Min	Typ	Max	Units
Storage Temperature Range		-40		70	$^{\circ}$ C
Operating Temperature Range		-15		50	$^{\circ}$ C
Operating Humidity	Non-condensing	10		90	%
Storage Humidity	Non-condensing	5		90	%
Altitude	(Without derating at 40 $^{\circ}$ C)		3000		m
	(Without derating at 50 $^{\circ}$ C)		1800		
Shock	30G non-operating				
Sinusoidal Vibration	0.5G, 5 – 500 Hz				
MTBF	Calculated per Telcordia SR-332 @40 $^{\circ}$ C	220K			hrs
Weight			7		kg
Safety Approvals	CAN/CSA C22.2 No 60950-1-07, Am.1:2011, Am 2:2014 ANSI/UL 60950-1-2014 IEC60950-1:2005 (2nd Ed.), Am 1:2009 + Am 2:2013 EN 60950-1:2006+A11:2009 +A1:2010 +A12:2011 +A2:2013				
Input Fuses	Power Supply has one internal 16A/500V fast blow fuse on each of the three AC line inputs.				
Material Flammability	UL 94V0				

### PROTECTION CHARACTERISTICS

Output	Parameter	Conditions	Min	Typ	Max	Units
380V	Over-temperature (intake)	Auto-restart	57	60	63	$^{\circ}$ C
	Over Voltage	Latching	418		445	V
	Over Current Range 1	Hiccup or Latching	105		130	%
	Over Current Range 2	Hiccup or Latching	105		130	%
3.3VSB	Over Voltage	Latching	3.9		4.3	V
	Over Current	Hiccup	6.3		9	A
5VSB	Over Voltage	Latching	5.6		6.0	V
	Over Current	Hiccup	4.2		6	A

EMISSIONS AND IMMUNITY		
Characteristic	Standard	Compliance
Input Current Harmonics	IEC/EN 61000-3-2	Complies
Conducted Emissions	FCC 47 CFR Parts 15	Class A, 6dB margin
Radiated Emissions (in the application)	CISPR 22 EN55022	Class A, 6dB margin
ESD Immunity	IEC/EN 61000-4-2	Level 3 criteria A
Radiated Field Immunity	IEC/EN 61000-4-3	Level 3 criteria B
Electrical Fast Transients/Burst Immunity	IEC/EN 61000-4-4	Level 3 criteria A
Surge Immunity	IEC/EN 61000-4-5	Level 3 criteria A
RF Conducted Immunity	IEC/EN 61000-4-6	Level 3 criteria A
Magnetic Field Immunity	IEC/EN 61000-4-8	3 A/m criteria B
Voltage Dips & Interruptions	IEC/EN 61000-4-11	400Vrms Input Voltage <b>54V &amp; VSB Outputs, Performance a)</b> 100% load, Phase 0°, Dip 100% Duration 10ms 50% load, Phase 0°, Dip 100% Duration 20ms <b>54V &amp; VSB Outputs, Performance b)</b> 100% load, Phase 0°, Dip 100% Duration >10ms Any Load, Phase 0°, Dip 100% Duration >100ms
Voltage imbalance (Circuit will stop when input voltage imbalance exceeds 8% for more than 100ms. Unit will restart when imbalance returns below 8%)		Any valid Input Voltage, any load <b>54V &amp; VSB Outputs, Performance a)</b> Dip 30% on single Phase or Line, Duration 100ms <b>54V &amp; VSB Outputs, Performance b)</b> Dip 30% on single Phase or Line, Duration >100ms

ISOLATION CHARACTERISTICS					
Parameter	Conditions	Min	Typ	Max	Units
Insulation Safety Rating/Test Voltage	Input to Output – Reinforced	3000			Vrms
	Input to Chassis – Basic	1500			Vrms
	Output to Chassis – Basic	1150			Vrms



STATUS INDICATORS (LEDs)			
Status Indicators	Input OK (Green)	Output OK (Green)	Fault4 (Yellow)
AC input voltage is not present	Off	Off	Off
AC present and within the required operational range Standby – ON; Main Output – OFF (disabled)	Solid Green	Blinking	Off
AC present, but its level is not within the required operational range	Blinking Green at 1Hz rate (0.5s on, 0.5s off)	Off	Off
When hot-unplugging the power supply from a power shelf <sup>3</sup>	Blinking Green at 1Hz rate (0.5s on, 0.5s off)	Off	Off
AC present and within the required operational range Standby – ON and within the specified regulation range Main Output – ON and within the specified regulation range	Solid Green	Solid Green	Off
AC present and within the required operational range Standby – ON and within the specified regulation range Main Output – ON and within the specified regulation range Power supply is in a power limit or in an overcurrent condition.	Solid Green	Solid Green	On
Any warning Levels (Input UV/OV, OC, Inlet Temp, Output and STBY OV/UV, OC, OTP, FAN)	No Change	No Change	Blinking 1Hz
Any Fault Levels (Input UV/OV, OC, Inlet Temp, Output and STBY OV/UV, OC, OTP, FAN)	Depends on PS Status	Depends on PS Status	Depends on PS Status

<sup>3</sup> The Input OK LED blinks to indicate that there is still energy inside the power supply until the input bulk capacitors are completely discharged or the housekeeping circuit is shut down.

<sup>4</sup> The Fault LED and PS Fault signal shall be turned on to indicate that there is one or more of the following internal faults currently detected inside the power supply:

- VSB out of range
- Output stage OT
- Fan fault
- ORING fault (Output voltage less than bus voltage)
- OC shutdown
- OT shutdown
- OV shutdown
- Input stage OT
- Fault induced shutdown occurred
- Thermal sensor fault
- Vout out of range
- PFC Boost Vbulk fault

As soon as all of the above faults are removed and the power supply operates normally, the Fault LED and PS Fault signal shall be turned off. LED Definition: Three LEDs shall be located on the front faceplate; these are:

LED	Status
	Input OK = ON
	Output OK = ON
	Fault = ON

Control Signals	
Signal (I/O)	Description
PS_ON_H	Internal 10K pull-up resistor to internal VDD. <sup>5</sup> <ul style="list-style-type: none"> <li>■ Leaving signal pin open = Main Output ON</li> <li>■ Tying signal pin to GND = Main Output OFF.</li> </ul>
PS_KILL	Short pin; internal 10K pull-up resistor to internal VDD. <sup>5</sup> <ul style="list-style-type: none"> <li>■ Leaving signal pin open = All Outputs off</li> <li>■ Tying signal pin to GND = All Outputs enabled.</li> </ul>
PS_FAULT_L	Internal 10K pull-up resistor to internal VDD. <sup>5</sup> <ul style="list-style-type: none"> <li>■ PSU Fault Status</li> </ul>
PWR_GOOD_H	Internal 10K pull-up resistor to internal VDD. <sup>5</sup> <ul style="list-style-type: none"> <li>■ Main Output Status OK</li> </ul>
STBY_SEL_IN	Internal 10K pull-up resistor to internal VDD. <sup>5</sup> <ul style="list-style-type: none"> <li>■ Leaving signal pin open = +5VSTBY</li> <li>■ Tying signal pin to GND = +3V3STBY</li> </ul>
AC_OK_H	Internal 10K pull-up resistor to internal VDD. <sup>5</sup> <ul style="list-style-type: none"> <li>■ AC OK Status</li> </ul>
SMB_ALERT_L	Internal 10K pull-up resistor to internal VDD. <sup>5</sup> <ul style="list-style-type: none"> <li>■ SMB Alert signal output</li> </ul>

<sup>5</sup>VDD depends on Standby Voltage selection of either 3.3V or 5V.

### OUTPUT CONNECTOR

Connector: FCI Power Blade Part # 51915-424

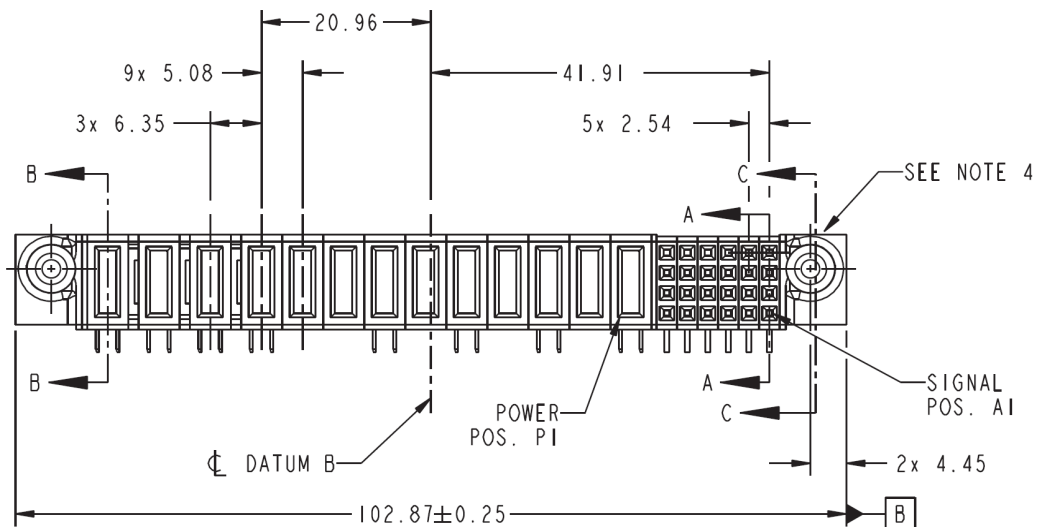

ROW S	POWER													SIGNAL					E1		
	E2	P13	P12	P11	P10	P9	P8	P7	P6	P5	P4	P3	P2	P1	6	5	4	3		2	1
D																					
C																					
B																					
A																					

### OUTPUT CONNECTOR & SIGNAL PIN ASSIGNMENT

Connector: FCI Power Blade Part # 51915-424

Power Blade Number	Signal	Function	Signal Direction
P13	-VOUT_PRE-CHARGE	Hot Swap Pre Charge	Output
P12	-VOUT	380Vdc Return	Output
P11	+VOUT_PRE-CHARGE	Hot Swap Pre Charge	Output
P10	+VOUT	380Vdc	Output
P9	Not fitted	-	-
P8	Not fitted	-	-
P7	AC1	AC Line Voltage Ph 1	Input
P6	Not fitted	-	-
P5	AC2	AC Line Voltage Ph 2	Input
P4	Not fitted	-	-
P3	AC3	AC Line Voltage Ph 3	Input
P2	Not fitted	-	-
P1	GND	Safety Ground	Input
Signal Pin Number	Signal	Function	Signal Direction
A1	A1	I2C Address Bit 1 Signal	Input
A2	PS_FAULT_L	PSU Fault Status	Output
A3	A0	I2C Address Bit 0 Signal	Input
A4	PS_PRESENT	PSU Seated into Connector	Output
A5	SCL	I2C Clock Signal	Bi-Directional
A6	SGND	Signal ground (return)	Output
B1	A2	I2C Address Bit 2 Signal	Input
B2	PS_ON_H	Enable PSU	Input
B3	+VSB	+3.3V/5V STBY Out	Output
B4	SDA	I2C Data Signal	Bi-Directional
B5	PS_KILL	Enable PSU Shortest pin of the connector	Input
B6	VSB_RTN	VSTBY_RTN	Output
C1	STBY_SEL_IN	Selects +3V3 or +5VSTBY	Input
C2	AC_OK_H	AC(DC) OK Status	Output
C3	+VSB	+3.3V/5V STBY Out	Output
C4	+VSB	+3.3V/5V STBY Out	Output
C5	VSB_RTN	VSTBY_RTN	Output
C6	VSB_RTN	VSTBY_RTN	Output
D1	SMB_ALERT_L	SMB Alert signal output	Output
D2	PWR_GOOD_H	Power OK Status	Output
D3	+VSB	+3.3V/5V STBY Out	Output
D4	+VSB	+3.3V/5V STBY Out	Output
D5	VSB_RTN	VSTBY_RTN	Output
D6	VSB_RTN	VSTBY_RTN	Output

### MATING CONNECTOR

Supplier	Press Fit, Straight	Press Fit, Right Angle	Solder Straight	Solder Right Angle
FCI				51938-826LF

### MECHANICAL DIMENSIONS

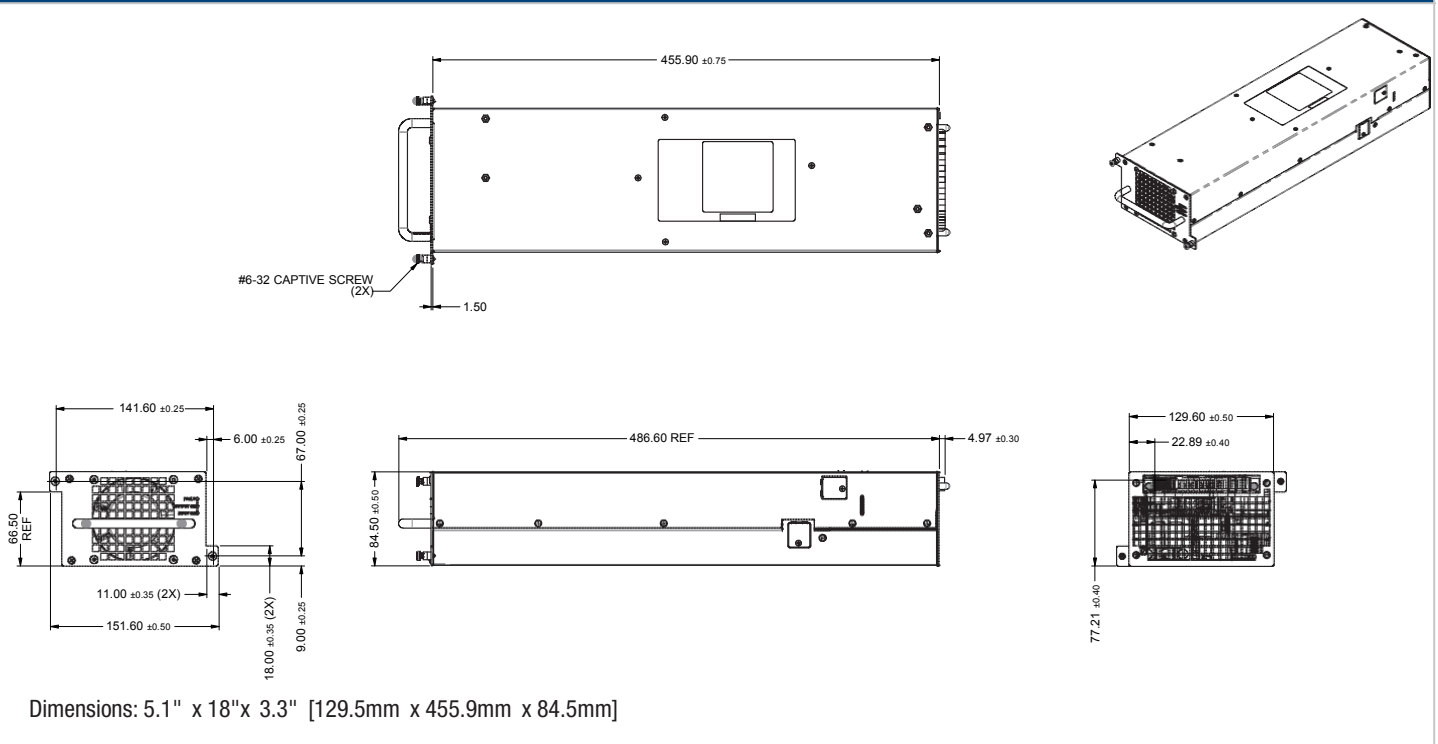

### OPTIONAL ACCESSORIES

Description	Part Number
12V D2U5T-380 Output Connector Card	D2U5T-380-CONC

### APPLICATION NOTES

Document Number	Description	Link
ACAN-62	D2U5T-380-CONC Customer Interface Connector Card	<a href="http://power.murata.com/datasheet/?/data/apnotes/acan-62.pdf">http://power.murata.com/datasheet/?/data/apnotes/acan-62.pdf</a>
ACAN-63	PMBus™ Communication Protocol for: D2U5T-H3-5000-380-Hu3C	<a href="http://power.murata.com/datasheet/?/data/apnotes/acan-63.pdf">http://power.murata.com/datasheet/?/data/apnotes/acan-63.pdf</a>

Murata Power Solutions, Inc.  
 11 Cabot Boulevard, Mansfield, MA 02048-1151 U.S.A.  
 ISO 9001 and 14001 REGISTERED



**This product is subject to the following operating requirements and the Life and Safety Critical Application Sales Policy:**  
 Refer to: <http://www.murata-ps.com/requirements/>

Murata Power Solutions, Inc. makes no representation that the use of its products in the circuits described herein, or the use of other technical information contained herein, will not infringe upon existing or future patent rights. The descriptions contained herein do not imply the granting of licenses to make, use, or sell equipment constructed in accordance therewith. Specifications are subject to change without notice. © 2016 Murata Power Solutions, Inc.





Компания «ЭлектроПласт» предлагает заключение долгосрочных отношений при поставках импортных электронных компонентов на взаимовыгодных условиях!

Наши преимущества:

- Оперативные поставки широкого спектра электронных компонентов отечественного и импортного производства напрямую от производителей и с крупнейших мировых складов;
- Поставка более 17-ти миллионов наименований электронных компонентов;
- Поставка сложных, дефицитных, либо снятых с производства позиций;
- Оперативные сроки поставки под заказ (от 5 рабочих дней);
- Экспресс доставка в любую точку России;
- Техническая поддержка проекта, помощь в подборе аналогов, поставка прототипов;
- Система менеджмента качества сертифицирована по Международному стандарту ISO 9001;
- Лицензия ФСБ на осуществление работ с использованием сведений, составляющих государственную тайну;
- Поставка специализированных компонентов (Xilinx, Altera, Analog Devices, Intersil, Interpoint, Microsemi, Aeroflex, Peregrine, Syfer, Eurofarad, Texas Instrument, Miteq, Cobham, E2V, MA-COM, Hittite, Mini-Circuits, General Dynamics и др.);

Помимо этого, одним из направлений компании «ЭлектроПласт» является направление «Источники питания». Мы предлагаем Вам помощь Конструкторского отдела:

- Подбор оптимального решения, техническое обоснование при выборе компонента;
- Подбор аналогов;
- Консультации по применению компонента;
- Поставка образцов и прототипов;
- Техническая поддержка проекта;
- Защита от снятия компонента с производства.



#### Как с нами связаться

**Телефон:** 8 (812) 309 58 32 (многоканальный)

**Факс:** 8 (812) 320-02-42

**Электронная почта:** [org@eplast1.ru](mailto:org@eplast1.ru)

**Адрес:** 198099, г. Санкт-Петербург, ул. Калинина, дом 2, корпус 4, литера А.