

Features

- Attenuation 2-dB Steps to 30 dB
- High Accuracy
- Low Intermodulation Product: +50 dBm IP3
- Low DC Power Consumption: 50 μ W
- SOIC-16 Plastic Package
- Tape and Reel Packaging Available
- Temperature Stability +/-0.15 dB: -40°C to +85°C

Description

M/A-COM's AT-220 is a 4-bit, 2-dB step GaAs MMIC digital attenuator in a low cost SOIC 16-lead surface mount plastic package. The AT-220 is ideally suited for use where high accuracy, fast switching, very low power consumption and low intermodulation products are required. Typical applications include radio and cellular equipment, wireless LANs, GPS equipment and other Gain/Level Control circuits.

The AT-220 is fabricated with a monolithic GaAs MMIC using a mature 1-micron process. The process features full chip passivation for increased performance and reliability.

Ordering Information

Part Number	Package
AT-220 PIN	SOIC 16-Lead Plastic Package
AT-220TR*	1000 piece reel

* Reference Application Note M513 for reel size information.

Functional Schematic

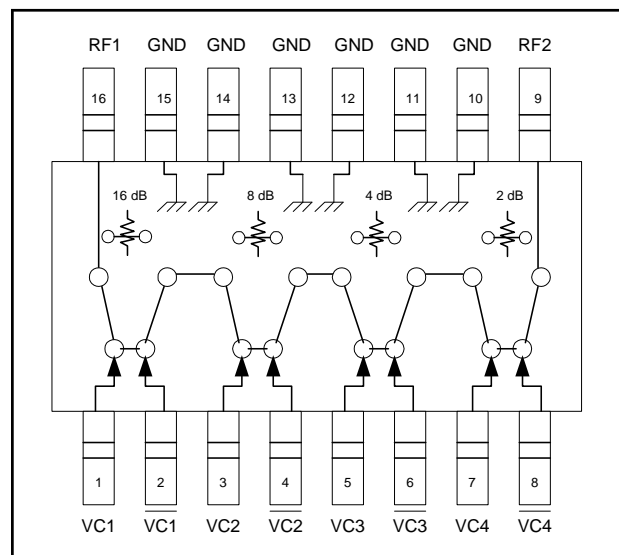

Pin Configuration

Pin No.	Function	Pin No.	Function
1	VC1	9	RF2
2	VC1	10	GND
3	VC2	11	GND
4	VC2	12	GND
5	VC3	13	GND
6	VC3	14	GND
7	VC4	15	GND
8	VC4	16	RF1

Absolute Maximum Ratings ¹

Parameter	Absolute Maximum
Input Power: 50 MHz 500-2000 MHz	+27 dBm +34 dBm
Control Voltage	-8.5 V \leq V _C \leq 5V
Operating Temperature	-40°C to +85°C
Storage Temperature	-65°C to +150°C

1. Exceeding any one or combination of these limits may cause permanent damage to this device.

Digital Attenuator, 30 dB, 4-Bit DC - 2.0 GHz

Rev. V5

Electrical Specifications: $T_A = 25^\circ\text{C}$, $V_C = 0\text{ V} / -5\text{ V}$, $Z_0 = 50\ \Omega$

Parameter	Test Conditions	Frequency	Units	Min	Typ	Max
Insertion Loss (reference state)		DC - 0.5 GHz	dB	—	1.5	1.7
		DC - 1.0 GHz	dB	—	1.6	1.8
		DC - 2.0 GHz	dB	—	1.8	2.1
Attenuation Accuracy ²		DC - 1.0 GHz DC - 2.0 GHz		$\pm (0.15\text{ dB} + 3\% \text{ of Atten Setting in dB})\text{ dB}$ $\pm (0.30\text{ dB} + 4\% \text{ of Atten Setting in dB})\text{ dB}$		
VSWR			Ratio	—	1.2:1	—
Trise, Tfall	10% to 90% RF, 90% to 10% RF	—	nS	—	12	—
Ton, Toff	50% Control to 90% RF, 50% Control to 10% RF	—	nS	—	18	—
Transients	In-Band	—	mV	—	25	—
1 dB Compression	Input Power Input Power	0.05 GHz	dBm	—	20	—
		0.5 - 2.0 GHz	dBm	—	28	—
IP ₂	Measured Relative to Input Power (For two-tone input power up to +5 dBm)	0.05 GHz	dBm	—	45	—
		0.5 - 2.0 GHz	dBm	—	68	—
IP ₃	Measured Relative to Input Power (For two-tone input power up to +5 dBm)	0.05 GHz	dBm	—	40	—
		0.5 - 2.0 GHz	dBm	—	50	—
Control Current	$ V_C = 5\text{ V}$		μA	—		100

2. Attenuation accuracy specifications apply with negative bias control and low inductance grounding.

SOIC-16

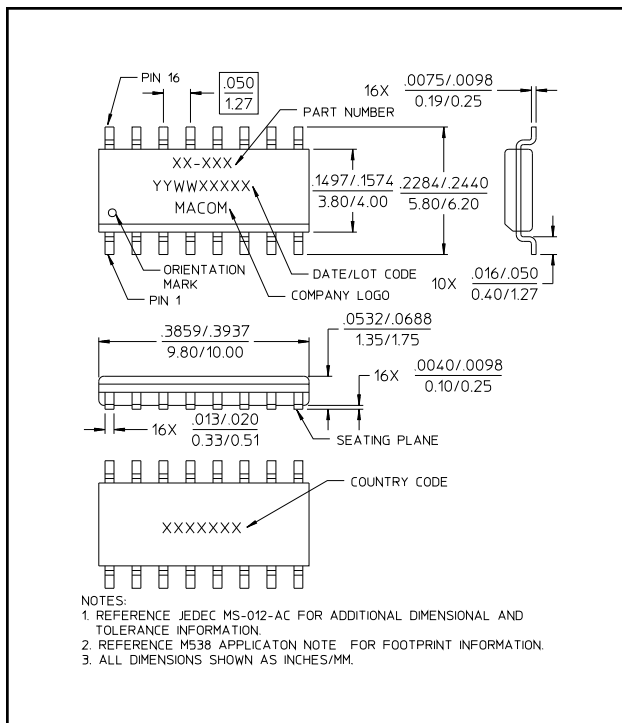

Truth Table ³

Control Inputs								Attenuation (dB)
$\overline{VC4}$	VC4	$\overline{VC3}$	VC3	$\overline{VC2}$	VC2	$\overline{VC1}$	VC1	
1	0	1	0	1	0	1	0	Reference State
0	1	1	0	1	0	1	0	2 dB
1	0	0	1	1	0	1	0	4 dB
1	0	1	0	0	1	1	0	8 dB
1	0	1	0	1	0	0	1	16 dB
0	1	0	1	0	1	0	1	30 dB

3. 0 = -0.2 V to 0 V, 1 = -8 V to -5 V.

2

ADVANCED: Data Sheets contain information regarding a product M/A-COM Technology Solutions is considering for development. Performance is based on target specifications, simulated results, and/or prototype measurements. Commitment to develop is not guaranteed.
PRELIMINARY: Data Sheets contain information regarding a product M/A-COM Technology Solutions has under development. Performance is based on engineering tests. Specifications are typical. Mechanical outline has been fixed. Engineering samples and/or test data may be available. Commitment to produce in volume is not guaranteed.

- **North America** Tel: 800.366.2266 / Fax: 978.366.2266
- **Europe** Tel: 44.1908.574.200 / Fax: 44.1908.574.300
- **Asia/Pacific** Tel: 81.44.844.8296 / Fax: 81.44.844.8298

Visit www.macomtech.com for additional data sheets and product information.

M/A-COM Technology Solutions Inc. and its affiliates reserve the right to make changes to the product(s) or information contained herein without notice.

Typical Performance Curves

Insertion Loss

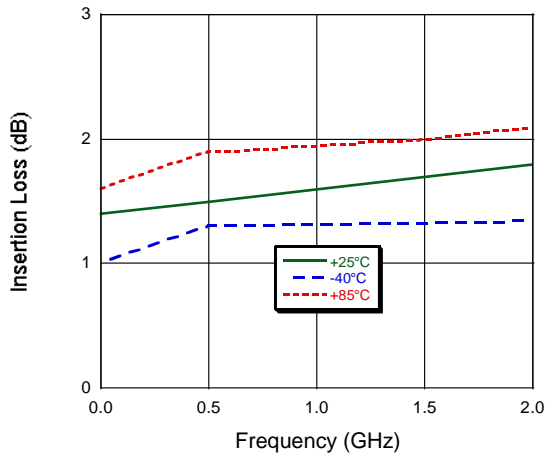

Attenuation

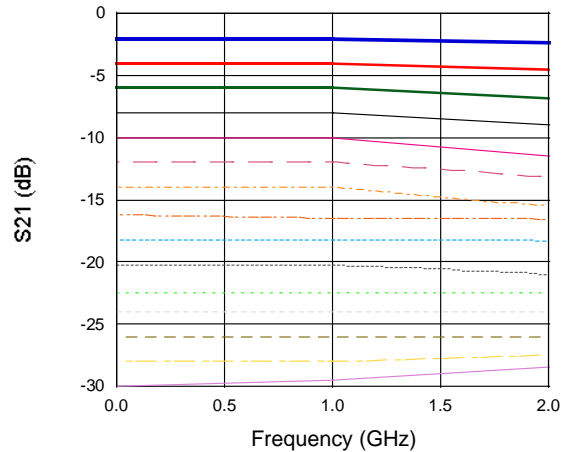

VSWR

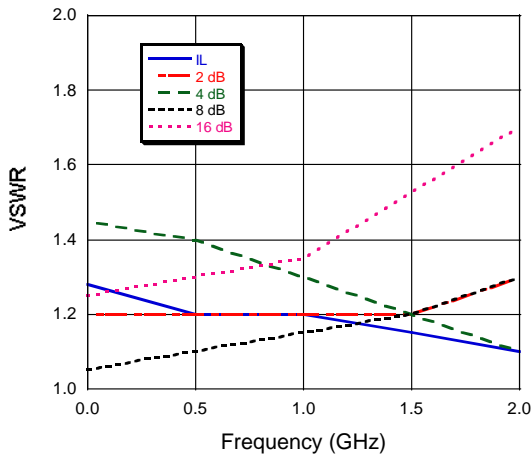

Attenuation Accuracy

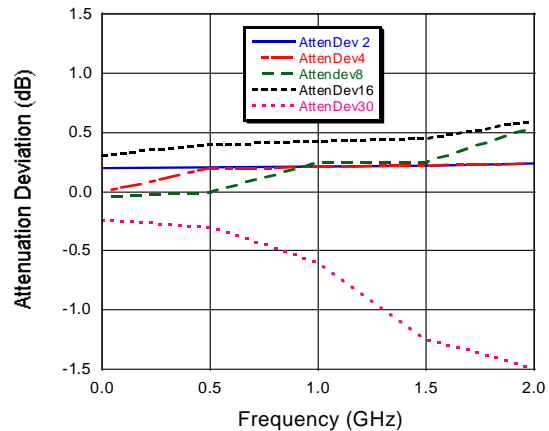



Компания «ЭлектроПласт» предлагает заключение долгосрочных отношений при поставках импортных электронных компонентов на взаимовыгодных условиях!

Наши преимущества:

- Оперативные поставки широкого спектра электронных компонентов отечественного и импортного производства напрямую от производителей и с крупнейших мировых складов;
- Поставка более 17-ти миллионов наименований электронных компонентов;
- Поставка сложных, дефицитных, либо снятых с производства позиций;
- Оперативные сроки поставки под заказ (от 5 рабочих дней);
- Экспресс доставка в любую точку России;
- Техническая поддержка проекта, помощь в подборе аналогов, поставка прототипов;
- Система менеджмента качества сертифицирована по Международному стандарту ISO 9001;
- Лицензия ФСБ на осуществление работ с использованием сведений, составляющих государственную тайну;
- Поставка специализированных компонентов (Xilinx, Altera, Analog Devices, Intersil, Interpoint, Microsemi, Aeroflex, Peregrine, Syfer, Eurofarad, Texas Instrument, Miteq, Cobham, E2V, MA-COM, Hittite, Mini-Circuits, General Dynamics и др.);

Помимо этого, одним из направлений компании «ЭлектроПласт» является направление «Источники питания». Мы предлагаем Вам помощь Конструкторского отдела:

- Подбор оптимального решения, техническое обоснование при выборе компонента;
- Подбор аналогов;
- Консультации по применению компонента;
- Поставка образцов и прототипов;
- Техническая поддержка проекта;
- Защита от снятия компонента с производства.



Как с нами связаться

Телефон: 8 (812) 309 58 32 (многоканальный)

Факс: 8 (812) 320-02-42

Электронная почта: org@eplast1.ru

Адрес: 198099, г. Санкт-Петербург, ул. Калинина, дом 2, корпус 4, литера А.