

LOC		DIST		REVISIONS			
GP	00	P	LTN	DESCRIPTION	DATE	DWN	APVD
		A		INITIAL RELEASE	24MAY2012	LW	AC
		A1		REV PER ECR-12-010636	19JUN2012	LW	AC

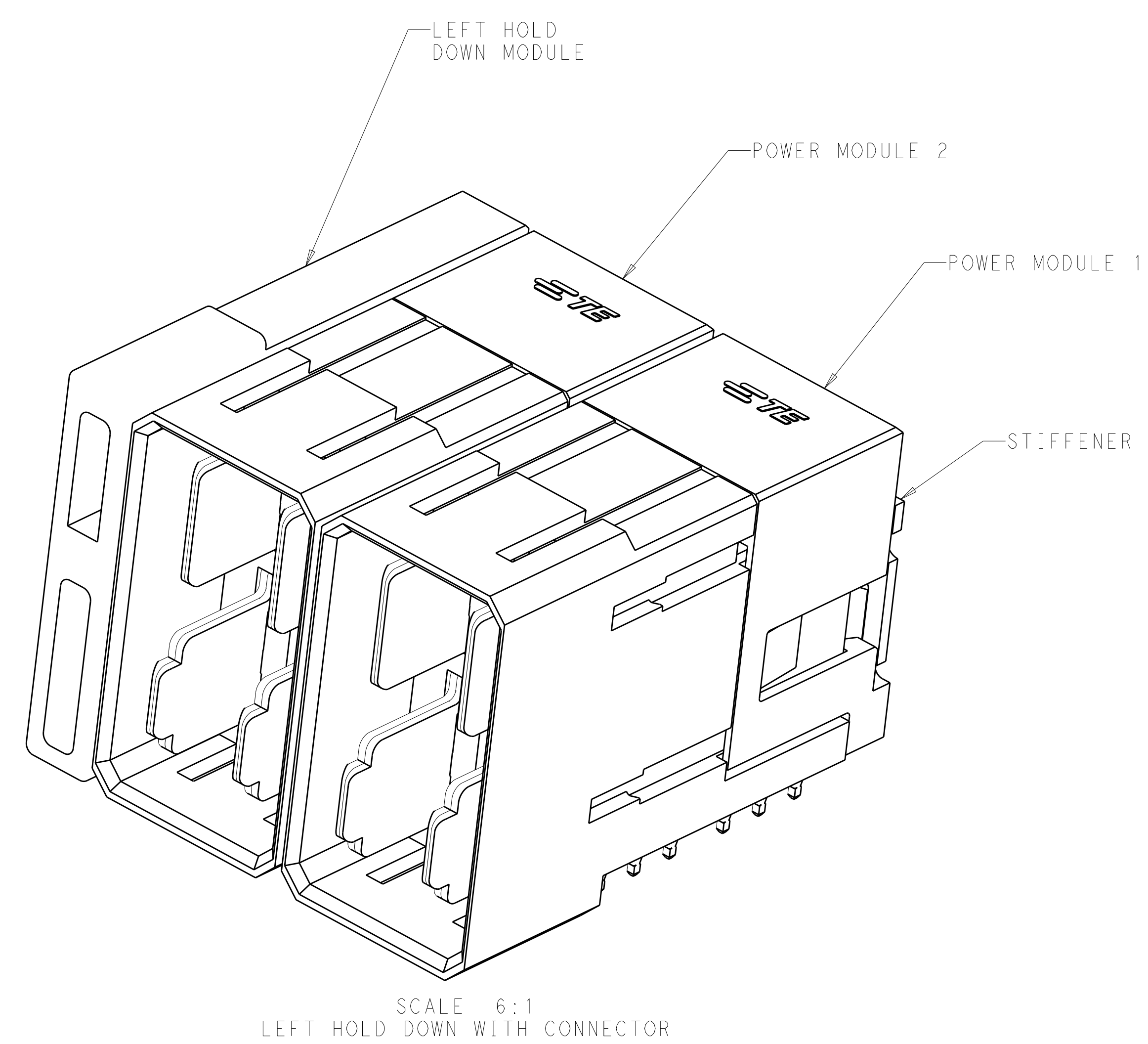

- NOTES:
- 1. MATERIALS:
HOUSING: HIGH TEMP. THERMOPLASTIC GLASS/MINERAL FILLED UL94V-0
TERMINAL: COPPER ALLOY
 - 2. FINISH:
TIN OPTION-0.76um MIN GOLD AT CONTACT AREA AND
1.27um MIN NICKEL UNDERPLATED OVER ALL
2.54um TIN AT SOLDER TAIL AREA
TIN-LEAD OPTION-0.76um MIN GOLD AT CONTACT AREA AND
1.27um MIN NICKEL UNDERPLATED OVER ALL
2.54um TIN-LEAD AT SOLDER TAIL AREA
 - 3. REFER TO TE'S PRODUCT SPECIFICATION:108-2473 FOR PLATED THROUGH-HOLE SPECIFICATION AND TORQUE FORCE
 - 4. CONNECTOR WERE PACKED BY TRAY
REFER TO TE'S PACKAGING SPECIFICATION:107-97874
 - 5. MATED WITH 2169809-*
 - 6. LASER MARK PART NUMBER AND DATE CODE (YYWWDS) CAN BE AT THE OPPOSITE SIDE
 - 7. ADD 11.40MM FOR EACH ADDITIONAL MODULE
 - 8. REFER TO DOCUMENT NUMBER:2169802 FOR INDIVIDUAL MODULE COMPONENT INFORMATION
 - 9. FIRST POWER MODULE(1#) STARTS FROM THE RIGHT
 - 10. DIMENSION P1&P2 FOR POWER MODULE 1, P3&P4 FOR POWER MODULE 2
 - 11. COMPONENT STAY AWAY ZONE FROM CONNECTOR
 - 12. ALL PARTS ARE SHIPPED WITH A 2-32 AB TYPE SELF-TAPPING SCREW P/N:2057509-2

STATUS	PACKAGING	PLATING TYP	P4	P3	P2	P1	DIM A	NUMBER OF POWER MODULE	PART NUMBER
OBSOLETE			6.90	5.70	6.90	5.70	26.40	2X	7-2180488-0
OBSOLETE			6.90	5.70	5.70	6.90	26.40	2X	6-2180488-9
OBSOLETE			6.90	5.70	5.70	5.70	26.40	2X	6-2180488-8
OBSOLETE			6.90	5.70	6.90	6.90	26.40	2X	6-2180488-7
OBSOLETE			5.70	6.90	6.90	5.70	26.40	2X	6-2180488-6
OBSOLETE			5.70	6.90	5.70	6.90	26.40	2X	6-2180488-5
OBSOLETE			5.70	6.90	5.70	5.70	26.40	2X	6-2180488-4
OBSOLETE			5.70	6.90	6.90	6.90	26.40	2X	6-2180488-3
OBSOLETE			5.70	5.70	6.90	5.70	26.40	2X	6-2180488-2
OBSOLETE			5.70	5.70	5.70	6.90	26.40	2X	6-2180488-1
OBSOLETE			5.70	5.70	5.70	5.70	26.40	2X	6-2180488-0
OBSOLETE			5.70	5.70	6.90	6.90	26.40	2X	5-2180488-9
OBSOLETE			6.90	6.90	6.90	5.70	26.40	2X	5-2180488-8
OBSOLETE			6.90	6.90	5.70	6.90	26.40	2X	5-2180488-7
OBSOLETE			6.90	6.90	5.70	5.70	26.40	2X	5-2180488-6
OBSOLETE			6.90	6.90	6.90	6.90	26.40	2X	5-2180488-5
OBSOLETE			N/A	N/A	6.90	5.70	15.00	1X	5-2180488-4
OBSOLETE			N/A	N/A	5.70	6.90	15.00	1X	5-2180488-3
OBSOLETE			N/A	N/A	5.70	5.70	15.00	1X	5-2180488-2
OBSOLETE			N/A	N/A	6.90	6.90	15.00	1X	5-2180488-1
ACTIVE			6.90	5.70	6.90	5.70	26.40	2X	2-2180488-0
ACTIVE			6.90	5.70	5.70	6.90	26.40	2X	1-2180488-9
ACTIVE			6.90	5.70	5.70	5.70	26.40	2X	1-2180488-8
ACTIVE			6.90	5.70	6.90	6.90	26.40	2X	1-2180488-7
ACTIVE			5.70	6.90	6.90	5.70	26.40	2X	1-2180488-6
ACTIVE			5.70	6.90	5.70	6.90	26.40	2X	1-2180488-5
ACTIVE			5.70	6.90	5.70	5.70	26.40	2X	1-2180488-4
ACTIVE			5.70	6.90	6.90	6.90	26.40	2X	1-2180488-3
ACTIVE			5.70	5.70	6.90	5.70	26.40	2X	1-2180488-2
ACTIVE			5.70	5.70	5.70	6.90	26.40	2X	1-2180488-1
ACTIVE			5.70	5.70	5.70	5.70	26.40	2X	1-2180488-0
ACTIVE			5.70	5.70	6.90	6.90	26.40	2X	2180488-9
ACTIVE			6.90	6.90	6.90	5.70	26.40	2X	2180488-8
ACTIVE			6.90	6.90	5.70	6.90	26.40	2X	2180488-7
ACTIVE			6.90	6.90	5.70	5.70	26.40	2X	2180488-6
ACTIVE			6.90	6.90	6.90	6.90	26.40	2X	2180488-5
ACTIVE			N/A	N/A	6.90	5.70	15.00	1X	2180488-4
ACTIVE			N/A	N/A	5.70	6.90	15.00	1X	2180488-3
ACTIVE			N/A	N/A	5.70	5.70	15.00	1X	2180488-2
ACTIVE			N/A	N/A	6.90	6.90	15.00	1X	2180488-1

THIS DRAWING IS A CONTROLLED DOCUMENT. DWN: LERRY WANG 06MAR2012
 CHK: SUNY ZHAO 06MAR2012
 APVD: SUNY ZHAO 06MAR2012

TE Connectivity

IMPACT POWER 4PAIR HEADER WITH LEFT HOLD DOWN PRESS FIT

114-32028

100779 ©=2180488

SCALE 4:1 SHEET 1 OF 3 REV A1

LOC	DIST	REVISIONS			
P	LTN	DESCRIPTION	DATE	DMN	APVD
-	-	SEE SHEET 1	-	-	-

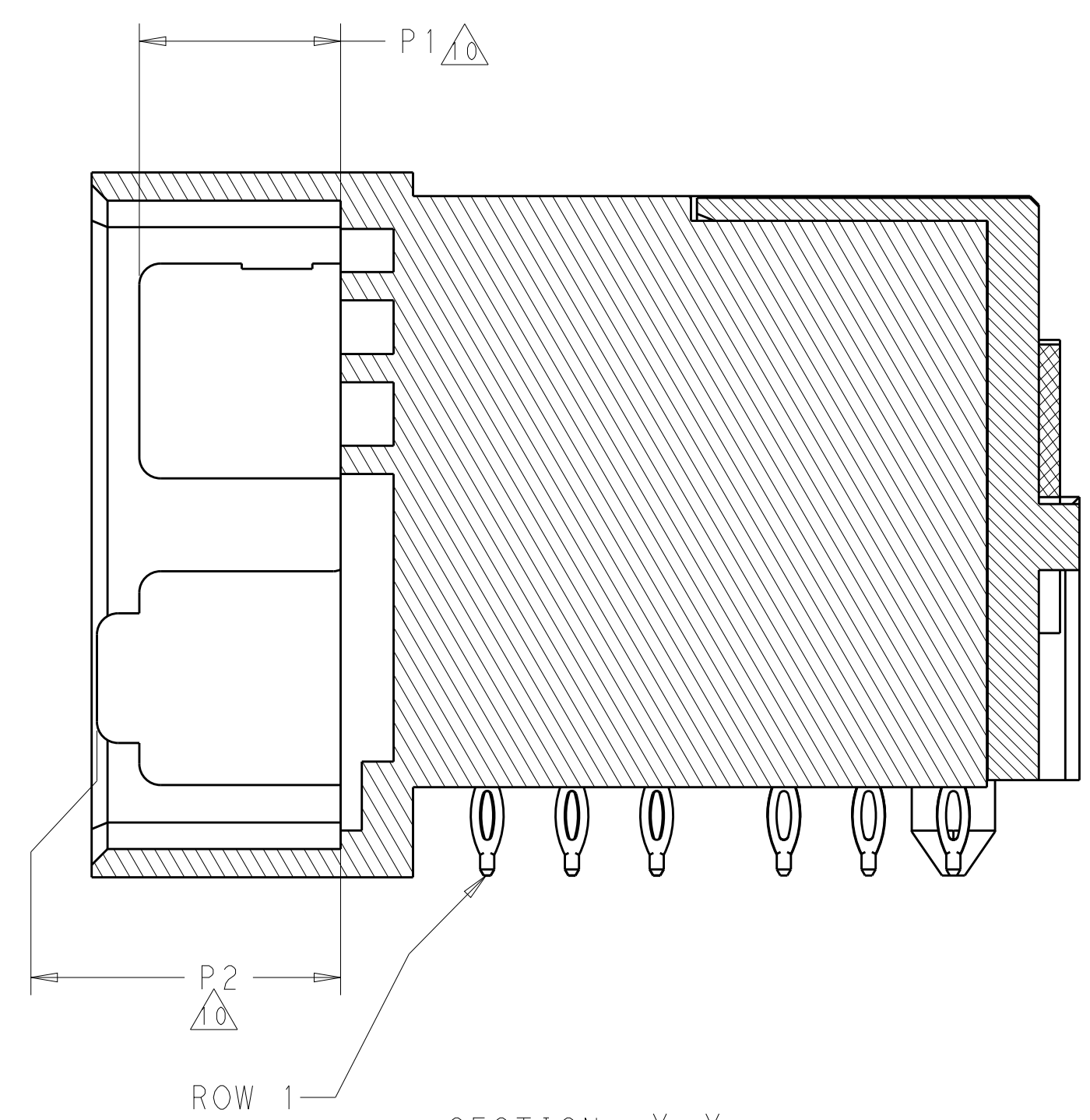
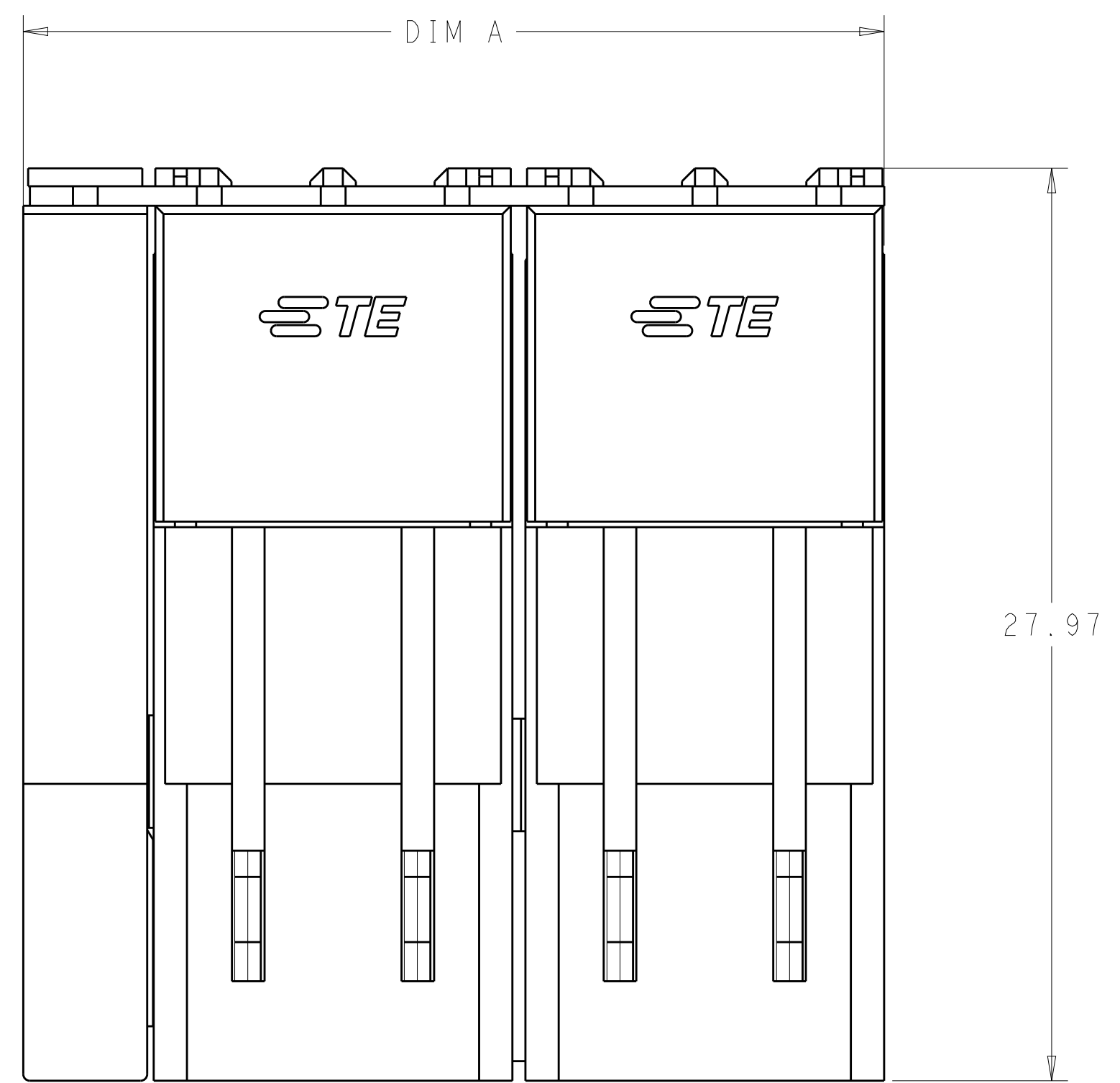

SECTION X-X
 BLADE LOCATION P1 & P2
 SCALE 6:1

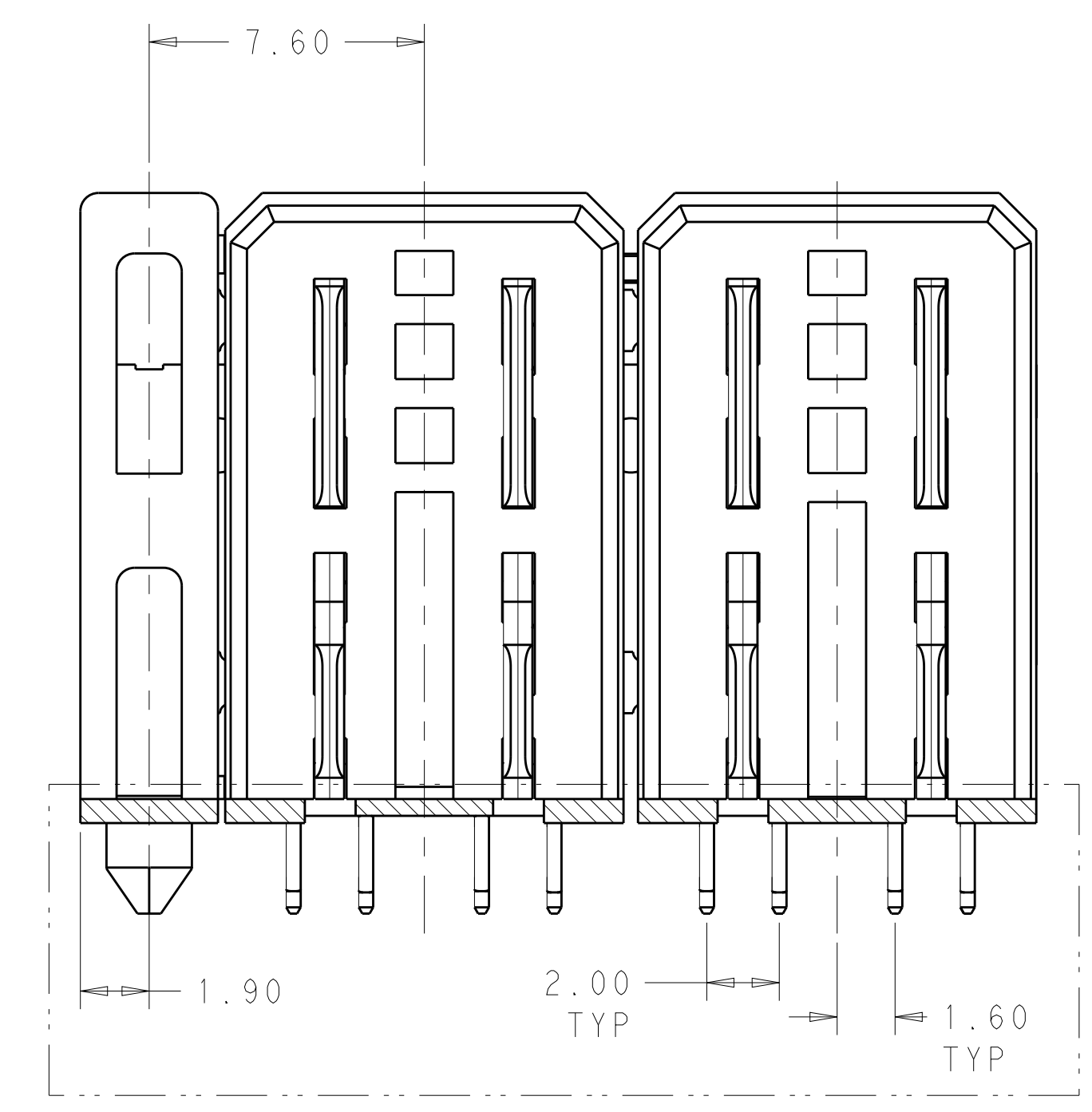
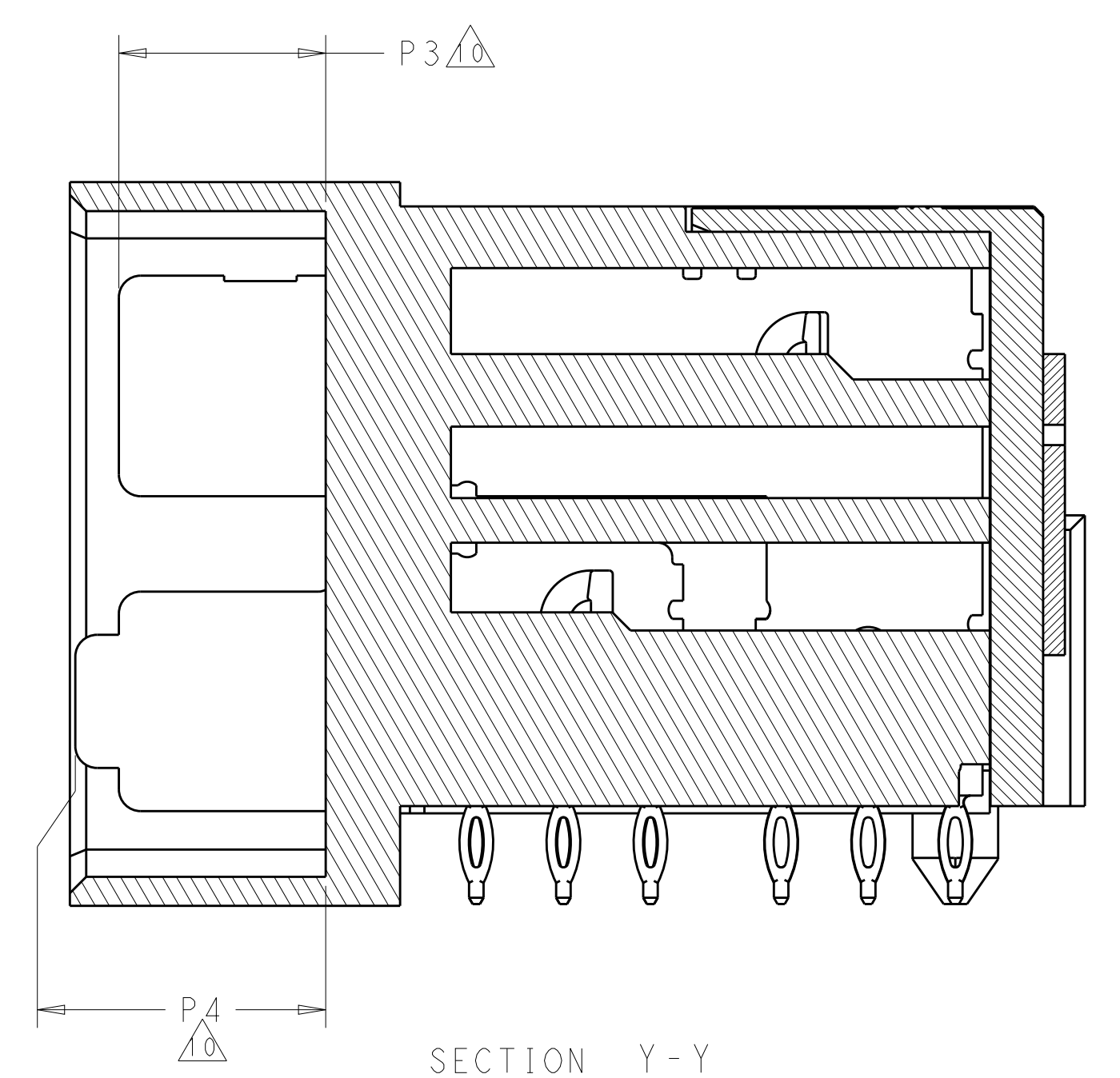
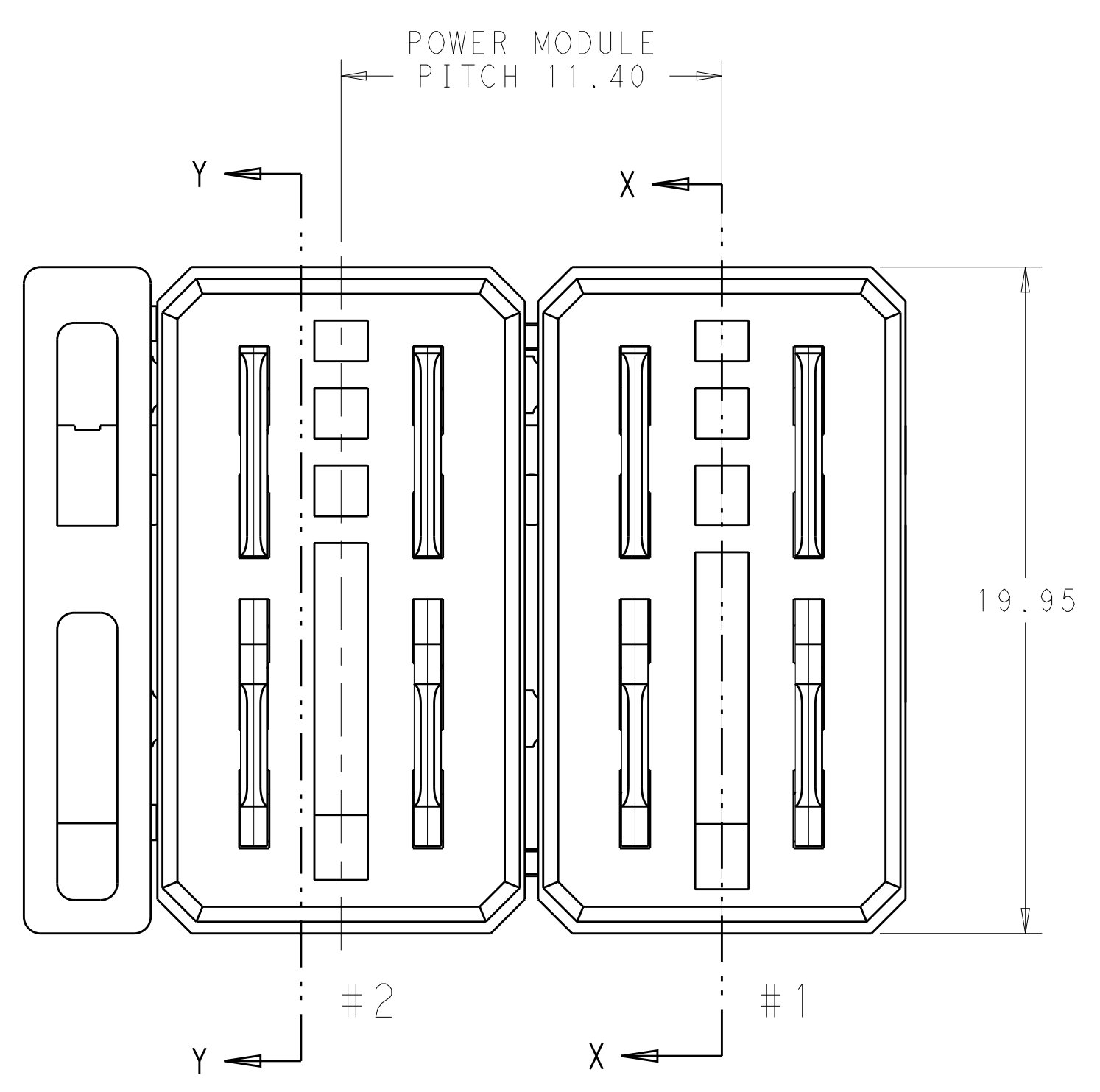
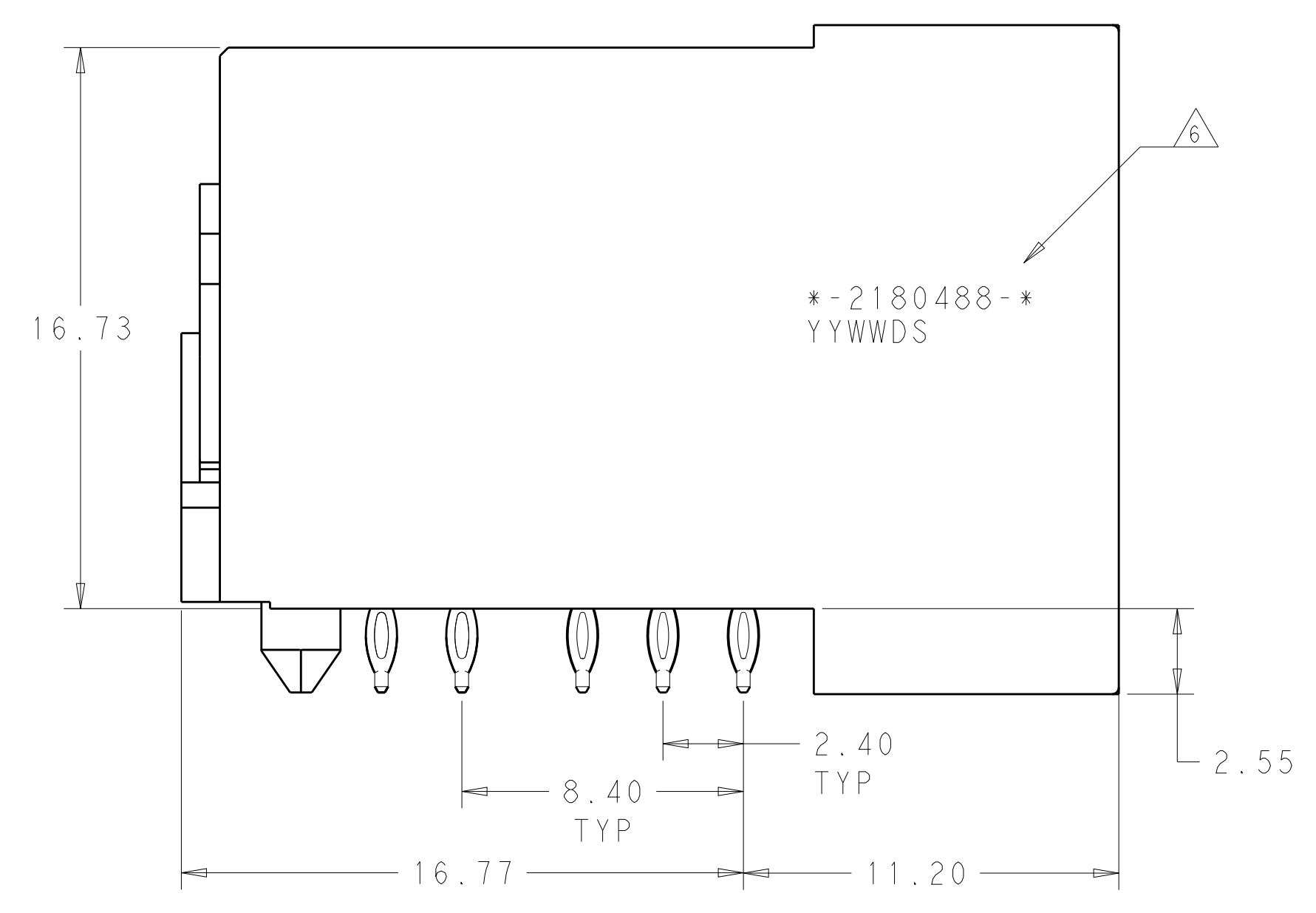

FIGURE: CUTAWAY
 SHOWN SOLDER TAIL POSITION



SECTION Y-Y
 BLADE LOCATION P3 & P4



THIS DRAWING IS A CONTROLLED DOCUMENT.		DMN: LERRY WANG 06MAR2012	TE Connectivity
DIMENSIONS:		CHK: SUNY ZHAO 06MAR2012	
mm	TOLERANCES UNLESS OTHERWISE SPECIFIED:	APVD: SUNY ZHAO 06MAR2012	NAME: IMPACT POWER 4PAIR HEADER WITH LEFT HOLD DOWN PRESS FIT
0 PLC ±.05 1 PLC ±.05 2 PLC ±.05 3 PLC ±.05 4 PLC ±.05 ANGLES ±.05°	MATERIAL: - FINISH: -	PRODUCT SPEC: APPLICATION SPEC: 114-32028 WEIGHT: -	
CUSTOMER DRAWING		SCALE: 4:1	SHEET 2 OF 3 REV A1

LOC	DIST	REVISIONS			
GP	00	REV	DATE	BY	APPV
-	-	SEE SHEET 1	-	-	-

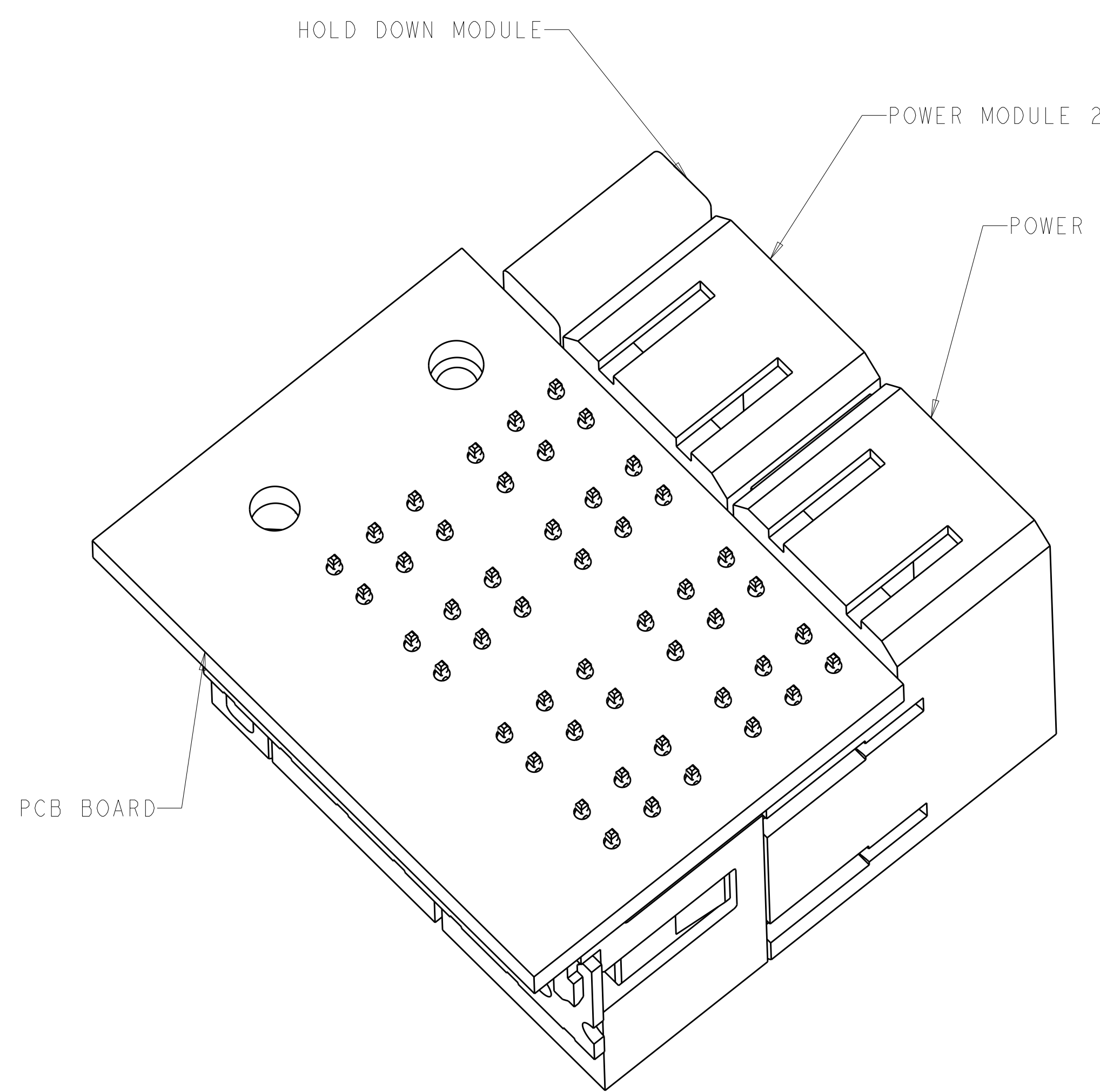

CONNECTOR WITH PCB BOARD

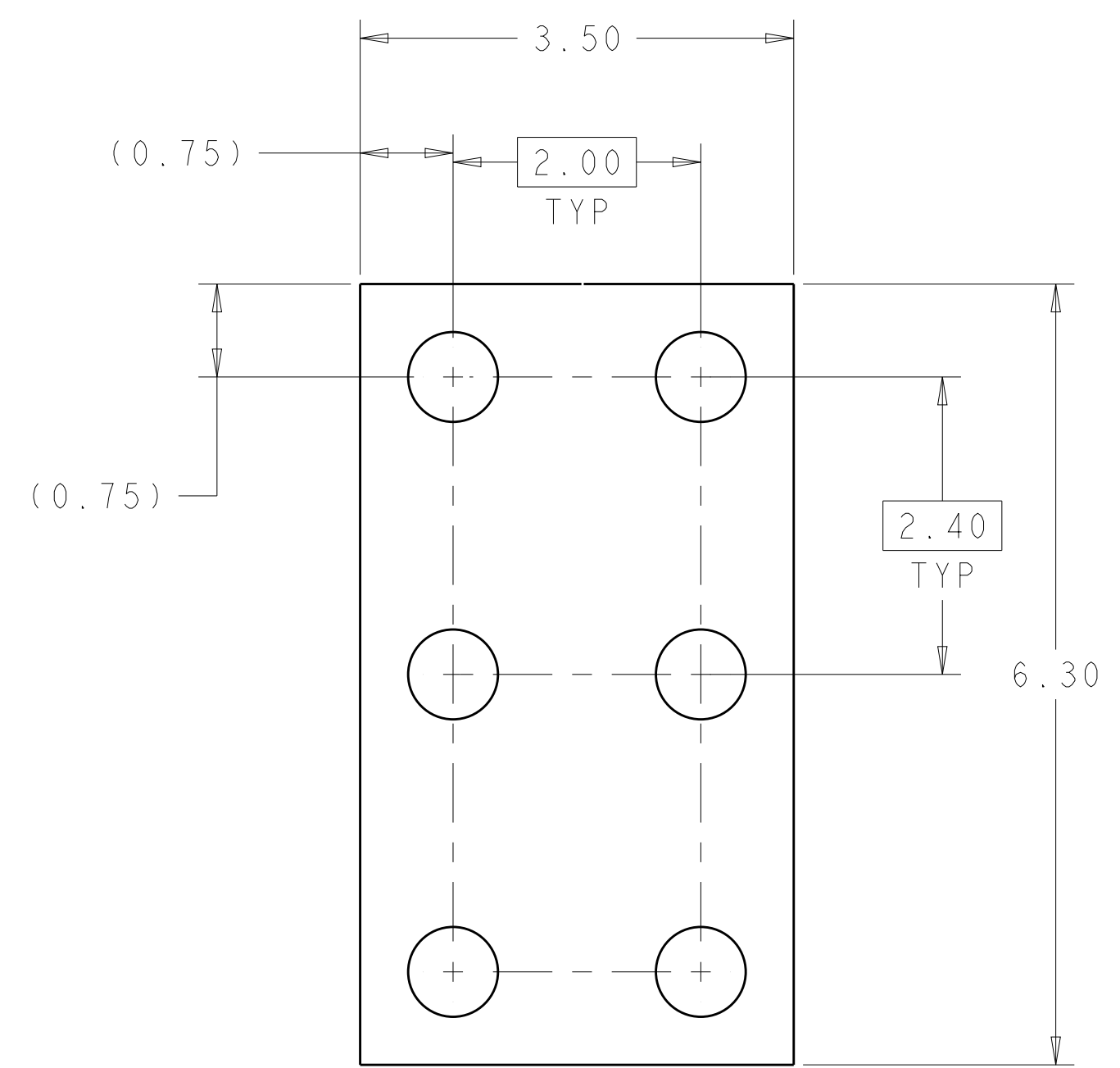

DETAIL A
COPPER PAD REFERENCE
SCALE 20:1

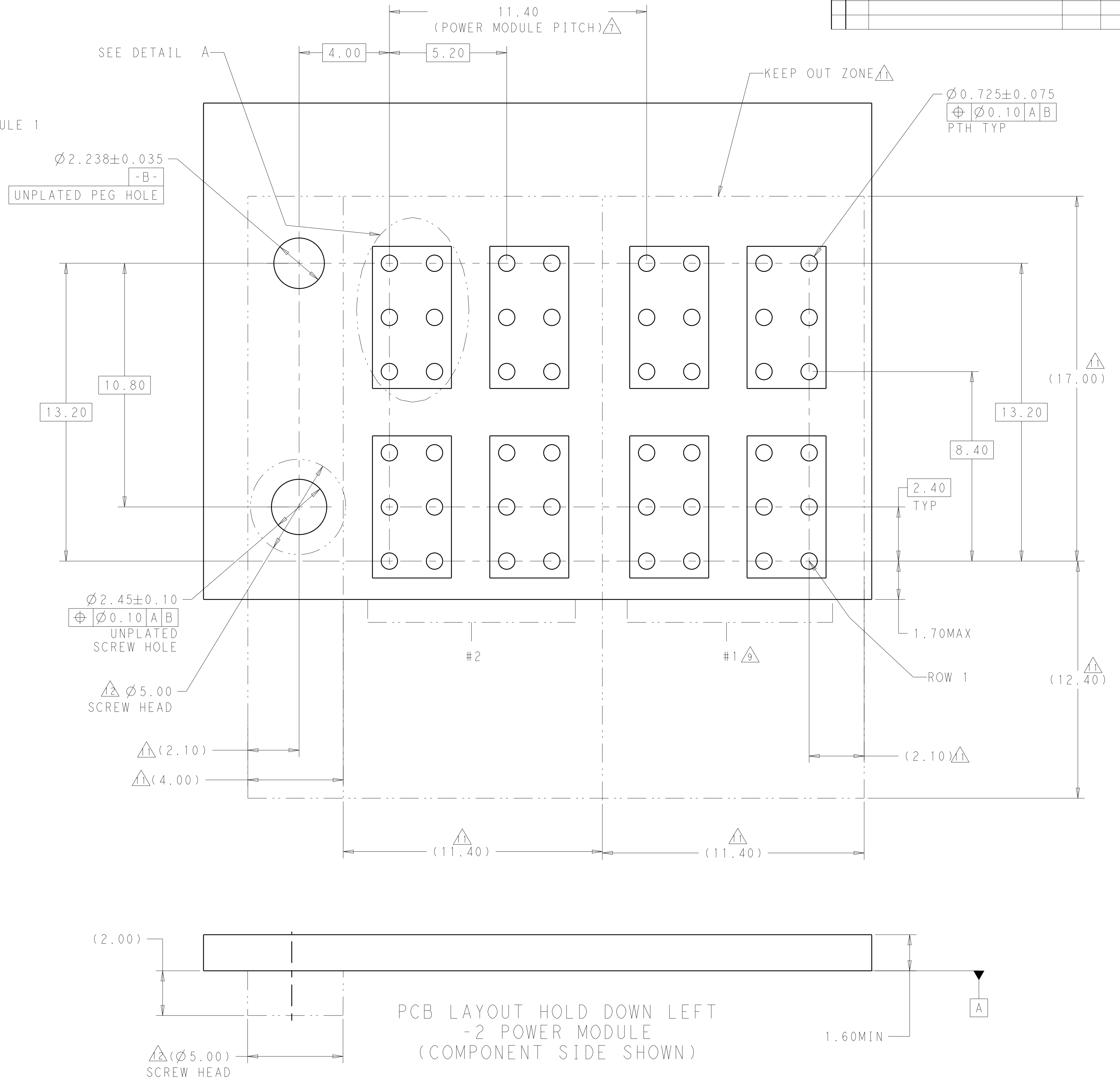

THIS DRAWING IS A CONTROLLED DOCUMENT.		OWN: LERRY WANG 06MAR2012	 TE Connectivity
DIMENSIONS: mm		CHK: SUNY ZHAO 06MAR2012	
TOLERANCES UNLESS OTHERWISE SPECIFIED:		APVD: SUNY ZHAO 06MAR2012	NAME: IMPACT POWER 4PAIR HEADER WITH LEFT HOLD DOWN PRESS FIT
0 PLC ±0.10	1 PLC ±0.15	2 PLC ±0.25	PRODUCT SPEC
3 PLC ±0.30	4 PLC ±0.40	ANGLES ±0.5°	APPLICATION SPEC
MATERIAL: -	FINISH: -	WEIGHT: -	SIZE: 114-32028
CUSTOMER DRAWING		SCALE: 4:1	SHEET 3 OF 3



Компания «ЭлектроПласт» предлагает заключение долгосрочных отношений при поставках импортных электронных компонентов на взаимовыгодных условиях!

Наши преимущества:

- Оперативные поставки широкого спектра электронных компонентов отечественного и импортного производства напрямую от производителей и с крупнейших мировых складов;
- Поставка более 17-ти миллионов наименований электронных компонентов;
- Поставка сложных, дефицитных, либо снятых с производства позиций;
- Оперативные сроки поставки под заказ (от 5 рабочих дней);
- Экспресс доставка в любую точку России;
- Техническая поддержка проекта, помощь в подборе аналогов, поставка прототипов;
- Система менеджмента качества сертифицирована по Международному стандарту ISO 9001;
- Лицензия ФСБ на осуществление работ с использованием сведений, составляющих государственную тайну;
- Поставка специализированных компонентов (Xilinx, Altera, Analog Devices, Intersil, Interpoint, Microsemi, Aeroflex, Peregrine, Syfer, Eurofarad, Texas Instrument, Miteq, Cobham, E2V, MA-COM, Hittite, Mini-Circuits, General Dynamics и др.);

Помимо этого, одним из направлений компании «ЭлектроПласт» является направление «Источники питания». Мы предлагаем Вам помощь Конструкторского отдела:

- Подбор оптимального решения, техническое обоснование при выборе компонента;
- Подбор аналогов;
- Консультации по применению компонента;
- Поставка образцов и прототипов;
- Техническая поддержка проекта;
- Защита от снятия компонента с производства.



Как с нами связаться

Телефон: 8 (812) 309 58 32 (многоканальный)

Факс: 8 (812) 320-02-42

Электронная почта: org@eplast1.ru

Адрес: 198099, г. Санкт-Петербург, ул. Калинина, дом 2, корпус 4, литера А.