

AD7242/AD7244

FEATURES

Two 12-Bit/14-Bit DACs with Output Amplifiers

AD7242: 12-Bit Resolution

AD7244: 14-Bit Resolution

On-Chip Voltage Reference

Fast Settling Time

AD7242: 3 μ s to $\pm 1/2$ LSB

AD7244: 4 μ s to $\pm 1/2$ LSB

High Speed Serial Interface

Operates from ± 5 V Supplies

Specified Over -40°C to $+85^{\circ}\text{C}$ in Plastic Packages

Low Power – 130 mW typ

GENERAL DESCRIPTION

The AD7242/AD7244 is a fast, complete, dual 12-bit/14-bit voltage output D/A converter. It consists of a 12-bit/14-bit DAC, 3 V buried Zener reference, DAC output amplifiers and high speed serial interface logic.

Interfacing to both DACs is serial, minimizing pin count and allowing a small package size. Standard control signals allow interfacing to most DSP processors and microcontrollers.

Asynchronous control of DAC updating for both DACs is made possible with a separate $\overline{\text{LDAC}}$ input for each DAC.

The AD7242/AD7244 operates from ± 5 V power supplies, providing an analog output range of ± 3 V. A REF OUT/REF IN function allows the DACs to be driven from the on-chip 3 V reference or from an external reference source.

The AD7242/AD7244 is fabricated in Linear Compatible CMOS (LC²MOS), an advanced mixed technology process that combines precision bipolar circuits with low power CMOS logic. Both parts are available in a 24-pin, 0.3-inch wide, plastic or hermetic dual-in-line package (DIP) and in a 28-pin, plastic small outline (SOIC) package. The AD7242 and AD7244 are available in the same pinout to allow easy upgrade from 12-bit to 14-bit performance.

REV. A

Information furnished by Analog Devices is believed to be accurate and reliable. However, no responsibility is assumed by Analog Devices for its use, nor for any infringements of patents or other rights of third parties which may result from its use. No license is granted by implication or otherwise under any patent or patent rights of Analog Devices.

FUNCTIONAL BLOCK DIAGRAM

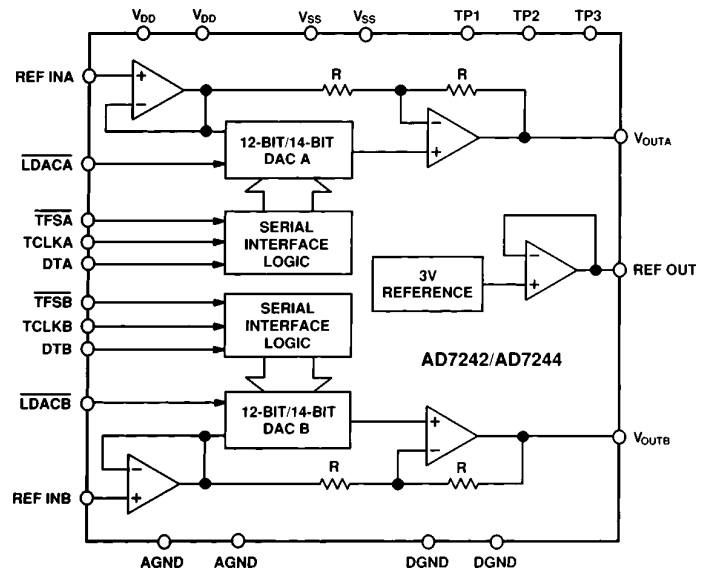

PRODUCT HIGHLIGHTS

- 1. Complete, Dual 12-Bit/14-Bit DACs**
 The AD7242/AD7244 provides the complete function for generating voltages to 12-bit/14-bit resolution. The part features an on-chip reference, output buffer amplifiers and two 12-bit/14-bit D/A converters.
- 2. High Speed Serial Interface**
 The AD7242/AD7244 provides a high speed, easy-to-use, serial interface allowing direct interfacing to DSP processors and microcontrollers. A separate serial port is provided for each DAC.
- 3. Small Package Size**
 The AD7242/AD7244 is available in a 24-pin DIP and a 28-pin SOIC package offering considerable space saving over comparable solutions.

AD7242/AD7244—SPECIFICATIONS ($V_{DD} = +5\text{ V} \pm 5\%$, $V_{SS} = -5\text{ V} \pm 5\%$, $AGND = DGND = 0\text{ V}$, $REF\ INA = REF\ INB = +3\text{ V}$. V_{OUTA} , V_{OUTB} load to $AGND$: $R_L = 2\text{ k}\Omega$, $C_L = 100\text{ pF}$.)

All Specifications T_{MIN} to T_{MAX} unless otherwise noted.)

| Parameter | AD7242 | | Units | Test Conditions/Comments |
|--|----------------------------|----------------------------|-------------------|---|
| | J, A Versions ¹ | K, B Versions ¹ | | |
| DC ACCURACY | | | | |
| Resolution | 12 | 12 | Bits | Guaranteed Monotonic |
| Integral Nonlinearity | ± 1 | $\pm 1/2$ | LSB max | |
| Differential Nonlinearity | ± 1 | ± 1 | LSB max | |
| Bipolar Zero Error | ± 5 | ± 5 | LSB max | |
| Positive Full-Scale Error ² | ± 5 | ± 5 | LSB max | |
| Negative Full-Scale Error ² | ± 5 | ± 5 | LSB max | |
| REFERENCE OUTPUT³ | | | | |
| REF OUT @ +25°C | 2.99/3.01 | 2.99/3.01 | V min/V max | Reference Load Current Change (0 μA –500 μA) |
| T_{MIN} to T_{MAX} | 2.98/3.02 | 2.98/3.02 | V min/V max | |
| REF OUT Tempco | 35 | 35 | ppm/°C typ | |
| Reference Load Change ($\Delta\text{REF OUT vs. } \Delta\text{I}$) | -1 | -1 | mV max | |
| REFERENCE INPUTS | | | | |
| REF INA, REF INB Input Range | 2.85/3.15 | 2.85/3.15 | V min/V max | 3 V \pm 5% |
| Input Current | 1 | 1 | μA max | |
| LOGIC INPUTS ($\overline{\text{LDACA}}$, $\overline{\text{LDACB}}$, $\overline{\text{TFSA}}$, $\overline{\text{TFSB}}$, $\overline{\text{TCLKA}}$, $\overline{\text{TCLKB}}$, $\overline{\text{DTA}}$, $\overline{\text{DTB}}$) | | | | |
| Input High Voltage, V_{INH} | 2.4 | 2.4 | V min | $V_{DD} = 5\text{ V} \pm 5\%$ $V_{DD} = 5\text{ V} \pm 5\%$ $V_{IN} = 0\text{ V}$ to V_{DD} |
| Input Low Voltage, V_{INL} | 0.8 | 0.8 | V max | |
| Input Current, I_{IN} | ± 10 | ± 10 | μA max | |
| Input Capacitance, C_{IN} ⁴ | 10 | 10 | pF max | |
| ANALOG OUTPUTS (V_{OUTA} , V_{OUTB}) | | | | |
| Output Voltage Range | ± 3 | ± 3 | V nom | |
| DC Output Impedance | 0.1 | 0.1 | Ω typ | |
| Short Circuit Current | 20 | 20 | mA typ | |
| AC CHARACTERISTICS⁴ | | | | |
| Voltage Output Settling Time | | | | Settling Time to Within $\pm 1/2$ LSB of Final Value Typically 2 μs |
| Positive Full-Scale Change | 3 | 3 | μs max | |
| Negative Full-Scale Change | 3 | 3 | μs max | Typically 2 μs |
| Digital-to-Analog Glitch Impulse | 10 | 10 | nV secs typ | DAC Code Change All 1s to All 0s |
| Digital Feedthrough | 2 | 2 | nV secs typ | |
| Channel-to-Channel Isolation | 110 | 110 | dB typ | $V_{OUT} = 10\text{ kHz}$ Sine Wave |
| POWER REQUIREMENTS | | | | |
| V_{DD} | +5 | +5 | V nom | $\pm 5\%$ for Specified Performance |
| V_{SS} | -5 | -5 | V nom | $\pm 5\%$ for Specified Performance |
| I_{DD} | 27 | 27 | mA max | Cumulative Current from the Two V_{DD} Pins |
| I_{SS} | 15 | 15 | mA max | Cumulative Current from the Two V_{SS} Pins |
| Total Power Dissipation | 195 | 195 | mW max | Typically 130 mW |

NOTES

¹Temperature ranges are as follows: J, K Versions: -40°C to $+85^\circ\text{C}$; A, B Versions: -40°C to $+85^\circ\text{C}$.

²Measured with respect to REF IN and includes bipolar offset error.

³For capacitive loads greater than 50 pF, a series resistor is required (see Internal Reference section).

⁴Sample tested @ +25°C to ensure compliance.

Specifications subject to change without notice.

AD7242 ORDERING GUIDE

| Model | Temperature Range | Integral Nonlinearity | Package Option* |
|----------|--|-----------------------|-----------------|
| AD7242JN | -40°C to $+85^\circ\text{C}$ | ± 1 LSB max | N-24 |
| AD7242KN | -40°C to $+85^\circ\text{C}$ | $\pm 1/2$ LSB max | N-24 |
| AD7242JR | -40°C to $+85^\circ\text{C}$ | ± 1 LSB max | R-28 |
| AD7242KR | -40°C to $+85^\circ\text{C}$ | $\pm 1/2$ LSB max | R-28 |
| AD7242AQ | -40°C to $+85^\circ\text{C}$ | ± 1 LSB max | Q-24 |
| AD7242BQ | -40°C to $+85^\circ\text{C}$ | $\pm 1/2$ LSB max | Q-24 |

*N = Plastic DIP; Q = Cerdip; R = Small Outline IC (SOIC).

| Parameter | AD7244 | | Units | Test Conditions/Comments |
|--|----------------------------|------------------------|-------------|--|
| | J, A Versions ¹ | S Version ¹ | | |
| DC ACCURACY | | | | |
| Resolution | 14 | 14 | Bits | Guaranteed Monotonic |
| Integral Nonlinearity | ±2 | ±2 | LSB max | |
| Differential Nonlinearity | ±1 | ±1 | LSB max | |
| Bipolar Zero Error | ±10 | ±10 | LSB max | |
| Positive Full-Scale Error ² | ±10 | ±10 | LSB max | |
| Negative Full-Scale Error ² | ±10 | ±10 | LSB max | |
| REFERENCE OUTPUT³ | | | | |
| REF OUT @ +25°C | 2.99/3.01 | 2.99/3.01 | V min/V max | Reference Load Current Change (0 µA–500 µA) |
| T _{MIN} to T _{MAX} | 2.98/3.02 | 2.98/3.02 | V min/V max | |
| REF OUT Tempco | 35 | 35 | ppm/°C typ | |
| Reference Load Change (ΔREF OUT vs. ΔI) | –1 | –1 | mV max | |
| REFERENCE INPUTS | | | | |
| REF INA, REF INB Input Range | 2.85/3.15 | 2.85/3.15 | V min/V max | 3 V ± 5% |
| Input Current | 1 | 1 | µA max | |
| LOGIC INPUTS (LDACA, LDACB, TFSA, TFSB, TCLKA, TCLKB, DTA, DTB) | | | | |
| Input High Voltage, V _{INH} | 2.4 | 2.4 | V min | V _{DD} = 5 V ± 5% V _{DD} = 5 V ± 5% V _{IN} = 0 V to V _{DD} |
| Input Low Voltage, V _{INL} | 0.8 | 0.8 | V max | |
| Input Current, I _{IN} | ±10 | ±10 | µA max | |
| Input Capacitance, C _{IN} ⁴ | 10 | 10 | pF max | |
| ANALOG OUTPUTS (V _{OUTA} , V _{OUTB}) | | | | |
| Output Voltage Range | ±3 | ±3 | V nom | |
| DC Output Impedance | 0.1 | 0.1 | Ω typ | |
| Short Circuit Current | 20 | 20 | mA typ | |
| AC CHARACTERISTICS⁴ | | | | |
| Voltage Output Settling Time | | | | Settling Time to Within ±1/2 LSB of Final Value Typically 2.5 µs |
| Positive Full-Scale Change | 4 | 4 | µs max | |
| Negative Full-Scale Change | 4 | 4 | µs max | Typically 2.5 µs |
| Digital-to-Analog Glitch Impulse | 10 | 10 | nV secs typ | DAC Code Change All 1s to All 0s |
| Digital Feedthrough | 2 | 2 | nV secs typ | V _{OUT} = 10 kHz Sine Wave |
| Channel-to-Channel Isolation | 110 | 110 | dB typ | |
| POWER REQUIREMENTS | | | | |
| V _{DD} | +5 | +5 | V nom | ±5% for Specified Performance |
| V _{SS} | –5 | –5 | V nom | ±5% for Specified Performance |
| I _{DD} | 27 | 28 | mA max | Cumulative Current from the Two V _{DD} Pins |
| I _{SS} | 15 | 15 | mA max | Cumulative Current from the Two V _{SS} Pins |
| Total Power Dissipation | 195 | 205 | mW max | Typically 130 mW |

NOTES

¹Temperature ranges are as follows: J Version: 0°C to +70°C; A Version: –40°C to +85°C; S Version: –55°C to +125°C.

²Measured with respect to REF IN and includes bipolar offset error.

³For capacitive loads greater than 50 pF, a series resistor is required (see Internal Reference section).

⁴Sample tested @ +25°C to ensure compliance.

Specifications subject to change without notice.

AD7244 ORDERING GUIDE

| Model ¹ | Temperature Range | Integral Nonlinearity | Package Option ² |
|-----------------------|-------------------|-----------------------|-----------------------------|
| AD7244JN | –40°C to +85°C | ±2 LSB max | N-24 |
| AD7244JR | –40°C to +85°C | ±2 LSB max | R-28 |
| AD7244AQ | –40°C to +85°C | ±2 LSB max | Q-24 |
| AD7244SQ ³ | –55°C to +125°C | ±2 LSB max | Q-24 |

NOTES

¹To order MIL-STD-883, Class B, processed parts, add /883B to part number.

Contact local sales office for military data sheet and availability.

²N = Plastic DIP; Q = Cerdip; R = Small Outline IC (SOIC).

³This grade will be available to /883B processing only.

AD7242/AD7244

TIMING CHARACTERISTICS^{1, 2} ($V_{DD} = +5\text{ V} \pm 5\%$, $V_{SS} = -5\text{ V} \pm 5\%$, $AGND = DGND = 0\text{ V}$)

| Parameter | Limit at T_{MIN} , T_{MAX} (J, K, A, B Versions) | Limit at T_{MIN} , T_{MAX} (S Version) | Units | Conditions/Comments |
|-----------|---|---|--------|---------------------------------------|
| t_1 | 50 | 50 | ns min | \overline{TFS} to TCLK Falling Edge |
| t_2 | 75 | 100 | ns min | TCLK Falling Edge to \overline{TFS} |
| t_3^3 | 150 | 200 | ns min | TCLK Cycle Time |
| t_4 | 30 | 40 | ns min | Data Valid to TCLK Setup Time |
| t_5 | 75 | 100 | ns min | Data Valid to TCLK Hold Time |
| t_6 | 40 | 40 | ns min | \overline{LDAC} Pulse Width |

NOTES

¹Timing specifications are sample tested at +25°C to ensure compliance. All input signals are specified with $t_r = t_f = 5\text{ ns}$ (10% to 90% of 5 V) and timed from a voltage level of 1.6 V.

²See Figure 6.

³TCLK Mark/Space ratio is 40/60 to 60/40.

ABSOLUTE MAXIMUM RATINGS*

($T_A = +25^\circ\text{C}$ unless otherwise noted)

V_{DD} to AGND -0.3 V to +7 V

V_{SS} to AGND +0.3 V to -7 V

AGND to DGND -0.3 V to $V_{DD} + 0.3\text{ V}$

V_{OUT} to AGND V_{SS} to V_{DD}

REF OUT to AGND -0.3 V to $V_{DD} + 0.3\text{ V}$

REF INA, REF INB to AGND -0.3 V to $V_{DD} + 0.3\text{ V}$

Digital Inputs to DGND -0.3 V to $V_{DD} + 0.3\text{ V}$

Operating Temperature Range

J, K Versions

AD7244 0°C to $+70^\circ\text{C}$

AD7242 -40°C to $+85^\circ\text{C}$

A, B Versions -40°C to $+85^\circ\text{C}$

S Version -55°C to $+125^\circ\text{C}$

Storage Temperature Range -65°C to $+150^\circ\text{C}$

Lead Temperature (Soldering, 10 sec) $+300^\circ\text{C}$

Power Dissipation (Any Package) to $+75^\circ\text{C}$ 550 mW

Derates above $+75^\circ\text{C}$ by 6 mW/ $^\circ\text{C}$

*Stresses above those listed under "Absolute Maximum Ratings" may cause permanent damage to the device. This is a stress rating only, functional operation of the device at these or any other conditions above those listed in the operational sections of this specification is not implied. Exposure to absolute maximum rating conditions for extended periods may affect device reliability.

CAUTION

ESD (electrostatic discharge) sensitive device. Electrostatic charges as high as 4000 V readily accumulate on the human body and test equipment and can discharge without detection. Although the AD7242/AD7244 feature proprietary ESD protection circuitry, permanent damage may occur on devices subjected to high energy electrostatic discharges. Therefore, proper ESD precautions are recommended to avoid performance degradation or loss of functionality.



PIN CONFIGURATIONS

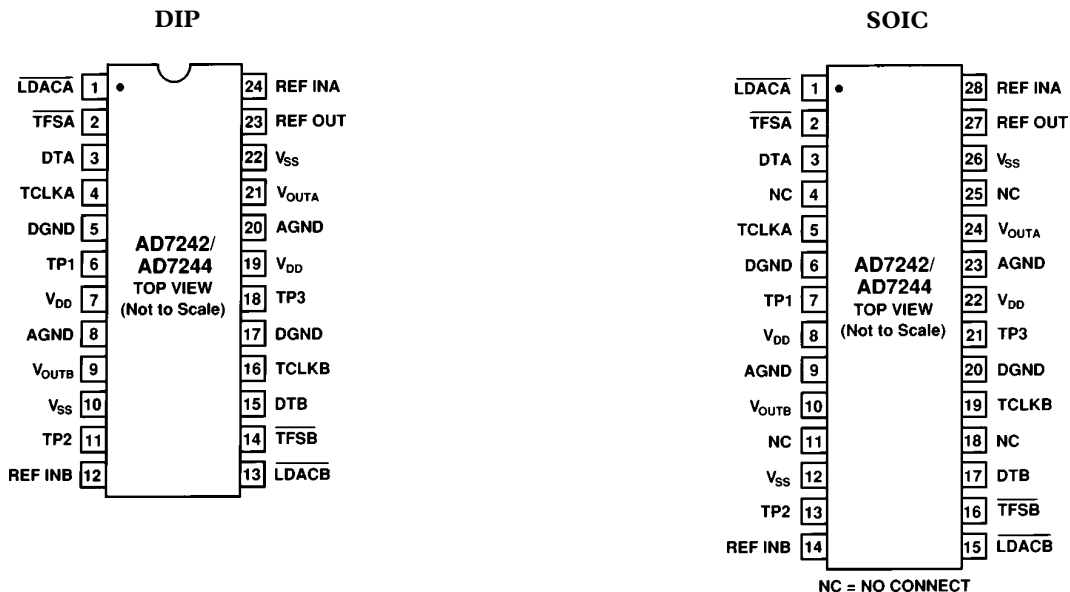

AD7242/AD7244 PIN FUNCTION DESCRIPTION

| DIP Pin No. | Mnemonic | Description |
|-------------|---------------------------|--|
| 1 | $\overline{\text{LDACA}}$ | Load DAC, Logic Input. A new word is transferred into DAC Latch A from input Latch A on the falling edge of this signal. If $\overline{\text{LDACA}}$ is hard-wired low, data is transferred from input Latch A to DAC Latch A on the sixteenth falling edge of TCLKA after TFSA goes low. |
| 2 | $\overline{\text{TFSA}}$ | Transmit Frame Synchronization, Logic Input. This is a frame or synchronization signal for DACA data with serial data expected after the falling edge of this signal. |
| 3 | DTA | Transmit Data, Logic Input. This is the data input which is used in conjunction with $\overline{\text{TFSA}}$ and TCLKA to transfer serial data to input Latch A. |
| 4 | TCLKA | Transmit Clock, Logic Input. Serial data bits for DACA are latched on the falling edge of TCLKA when $\overline{\text{TFSA}}$ is low. |
| 5 | DGND | Digital Ground. Both DGND pins for the device must be tied together at the device. |
| 6 | TP1 | Test Pin 1. Used when testing the device. Do not connect anything to this pin. |
| 7 | V _{DD} | Positive Power Supply, 5 V ± 5%. Both V _{DD} pins for the device must be tied together at the device. |
| 8 | AGND | Analog Ground. Both AGND pins for the device must be tied together at the device. |
| 9 | V _{OUTB} | Analog Output Voltage from DACB. This output comes from a buffer amplifier. The range is bipolar, ±3 V with REF INB = +3 V. |
| 10 | V _{SS} | Negative Power Supply, -5 V ± 5%. Both V _{SS} pins for the device must be tied together at the device. |
| 11 | TP2 | Test Pin 2. Used when testing the device. Do not connect anything to this pin. |
| 12 | REF INB | DACB Voltage Reference Input. The voltage reference for DACB is applied to this pin. It is internally buffered before being applied to DACB. The nominal reference voltage for correct operation of the AD7242/AD7244 is 3 V. |
| 13 | $\overline{\text{LDACB}}$ | Load DAC, Logic Input. A new word is transferred into DAC Latch B from input Latch B on the falling edge of this signal. If $\overline{\text{LDACB}}$ is hard-wired low, data is transferred from input Latch B to DAC Latch B on the sixteenth falling edge of TCLKB after $\overline{\text{TFSB}}$ goes low. |
| 14 | $\overline{\text{TFSB}}$ | Transmit Frame Synchronization, Logic Input. This is a frame or synchronization signal for DACB data with serial data expected after the falling edge of this signal. |
| 15 | DTB | Transmit Data, Logic Input. This is the data input used in conjunction with $\overline{\text{TFSB}}$ and TCLKB to transfer serial data to input Latch B. |
| 16 | TCLKB | Transmit Clock, Logic Input. Serial data bits for DACB are latched on the falling edge of TCLKB when $\overline{\text{TFSB}}$ is low. |
| 17 | DGND | Digital Ground. Both DGND pins for the device must be tied together at the device. |
| 18 | TP3 | Test Pin 3. Used when testing the device. Do not connect anything to this pin. |
| 19 | V _{DD} | Positive Power Supply, 5 V ± 5%. Both V _{DD} pins for the device must be tied together at the device. |
| 20 | AGND | Analog Ground. Both AGND pins for the device must be tied together at the device. |
| 21 | V _{OUTA} | Analog Output Voltage from DACA. This output comes from a buffer amplifier. The range is bipolar, ±3 V with REF INA = +3 V. |
| 22 | V _{SS} | Negative Power Supply, -5 V ± 5%. Both V _{SS} pins for the device must be tied together at the device. |
| 23 | REF OUT | Voltage Reference Output. To operate the DACs with this internal reference, REF OUT should be connected to both REF INA and REF INB. The external load capability of the reference is 500 μA. |
| 24 | REF INA | DACA Voltage Reference Input. The voltage reference for DACA is applied to this pin. It is internally buffered before being applied to DACA. The nominal reference voltage for correct operation of the AD7242/AD7244 is 3 V. |

AD7242/AD7244

CIRCUIT DESCRIPTION

The AD7242/AD7244 contains two 12-bit/14-bit D/A converters, each with an output buffer amplifier. The part also contains a reference input buffer amplifier for each DAC, and an on-chip 3 V reference.

D/A Section

The AD7242/AD7244 contains two 12-bit/14-bit voltage mode D/A converters, each consisting of highly stable thin-film resistors and high speed single-pole, double-throw switches. The simplified circuit diagram for the DAC section is shown in Figure 1. The three MSBs of the data word are decoded to drive the seven switches A-G. On the AD7242, the 9 LSBs switch a

9-bit R-2R ladder structure while on the AD7244, the 11 LSBs switch an 11-bit R-2R ladder structure. The output voltage from this converter has the same polarity as the reference voltage, REF IN.

The REF IN voltage is internally buffered by a unity gain amplifier before being applied to the D/A converters and the bipolar bias circuitry. The D/A converter is configured and scaled for a 3 V reference, and the device is tested with 3 V applied to REF IN. Operating the AD7242/AD7244 at reference voltages outside the $\pm 5\%$ tolerance range may result in degraded performance from the part.

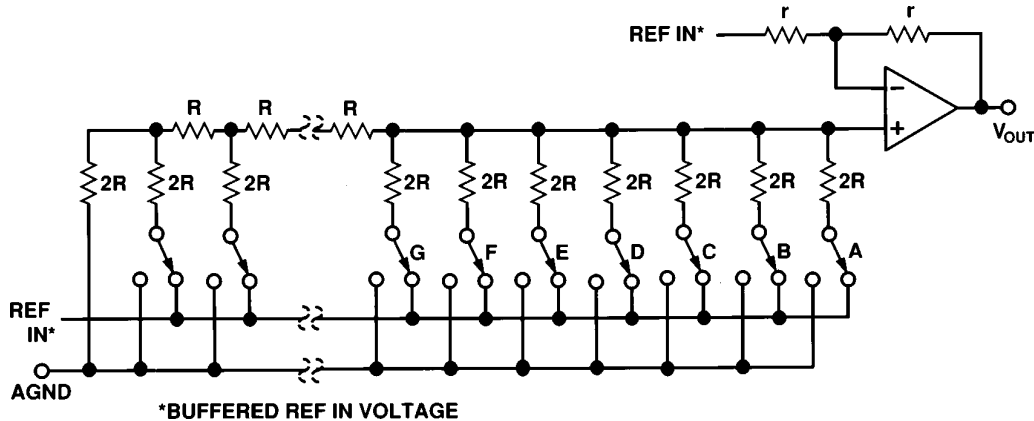

Figure 1. DAC Ladder Structure

Internal Reference

The on-chip reference is a temperature-compensated buried Zener reference that is factory trimmed for $3\text{ V} \pm 10\text{ mV}$. The reference can be used to provide both the reference voltage for the two D/A converters and the bipolar biasing circuitry. This is achieved by connecting REF OUT to REF INA and REF INB.

The reference voltage can also be used for other components and is capable of providing up to $500\ \mu\text{A}$ to an external load. The maximum recommended capacitance on the reference output pin for normal operation is 50 pF . If the reference output is required to drive a capacitive load greater than 50 pF , a $200\ \Omega$ resistor should be placed in series with the capacitive load. Decoupling the REF OUT pin with a series $200\ \Omega$ resistor and a parallel combination of a $10\ \mu\text{F}$ tantalum capacitor and a $0.1\ \mu\text{F}$ ceramic capacitor as in Figure 2 reduces the noise spectral density of the reference (see Figure 4). Using this decoupling scheme to generate the reference voltage for REF INA and REF INB gives a channel-to-channel isolation number of 110 dB (connecting REF OUT directly to REF INA and REF INB gives 80 dB). The channel-to-channel isolation is 110 dB using an external reference.

External Reference

In some applications, the user may require a system reference or some other external reference to drive the AD7242/AD7244 reference inputs. Figure 3 shows how the AD586 reference can be conditioned to provide the 3 V reference required by the AD7242/AD7244 reference inputs.

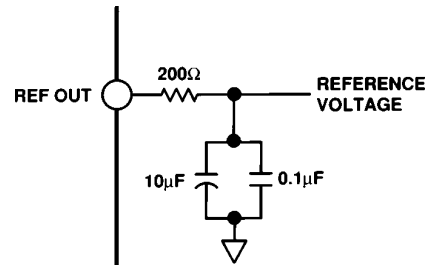

Figure 2. Circuit Connection for REF OUT with an External Capacitive Load of Greater Than 50 pF

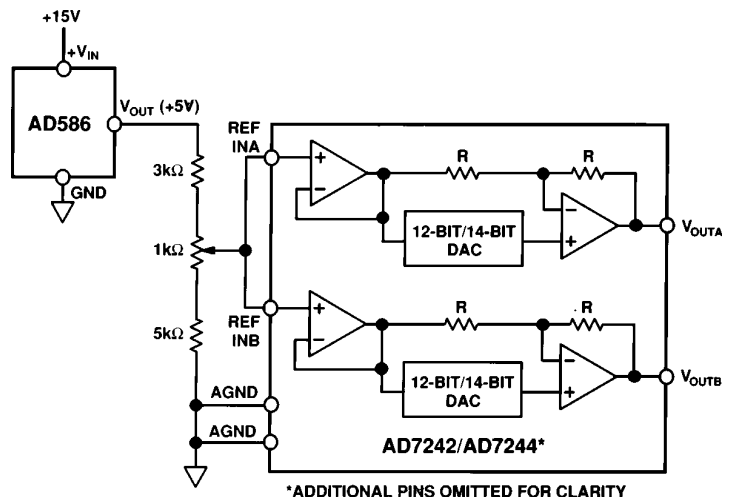

Figure 3. AD586 Driving AD7242/AD7244 Reference Inputs

Output Amplifier

The outputs from each of the voltage-mode DACs are buffered by a noninverting amplifier. The buffer amplifier is capable of developing ± 3 V across a 2 k Ω and 100 pF load to ground, and can produce 6 V peak-to-peak sine wave signals to a frequency of 20 kHz. The output is updated on the falling edge of the respective LDAC input. The output voltage settling time, to within 1/2 LSB of its final value, is typically less than 2 μ s for the AD7242 and 2.5 μ s for the AD7244.

The small signal (200 mV p-p) bandwidth of the output buffer amplifier is typically 1 MHz. The output noise from the amplifier is low, with a figure of 30 nV/ $\sqrt{\text{Hz}}$ at a frequency of 1 kHz. The broadband noise from the amplifier exhibits a typical peak-to-peak figure of 150 μ V for a 1 MHz output bandwidth. Figure 4 shows a typical plot of noise spectral density versus frequency for the output buffer amplifier and for the on-chip reference (including and excluding the decoupling components).



Figure 4. Noise Spectral Density vs. Frequency

TRANSFER FUNCTION

The basic circuit configuration for the AD7242/AD7244 is shown in Figure 5. Table I and Table II show the ideal input code to output voltage relationship for the AD7242 and AD7244 respectively. Input coding for the AD7242/AD7244 is 2s complement.

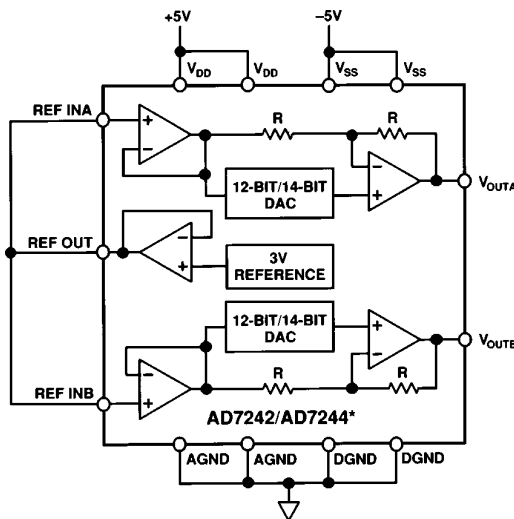

*ADDITIONAL PINS OMITTED FOR CLARITY

Figure 5. Basic Connection Diagram

For the AD7242, the output voltage can be expressed in terms of the input code, N , using the following relationship:

$$V_{OUT} = \frac{2 \cdot N \cdot REF\ IN}{4096}$$

where $-2048 \leq N \leq +2047$

For the AD7244, the output voltage can be expressed in terms of the input code, N , using the following relationship:

$$V_{OUT} = \frac{2 \cdot N \cdot REF\ IN}{16384}$$

where $-8192 \leq N \leq +8191$

Table I. AD7242 Ideal Input/Output Code Table Code

| DAC Latch Contents MSB | LSB | Analog Output, V_{OUT}^* |
|---------------------------|-----|----------------------------|
| 01 11 1111 1111 | | +2.998535 V |
| 01 11 1111 1110 | | +2.99707 V |
| 00 00 0000 0001 | | +0.001465 V |
| 00 00 0000 0000 | | 0 V |
| 11 11 1111 1111 | | -0.001465 V |
| 10 00 0000 0001 | | -2.998535 V |
| 10 00 0000 0000 | | -3 V |

*Assuming REF IN = +3 V.

Table II. AD7244 Ideal Input/Output Code Table Code

| DAC Latch Contents MSB | LSB | Analog Output, V_{OUT}^* |
|---------------------------|-----|----------------------------|
| 01 1111 1111 1111 | | +2.999634 V |
| 01 1111 1111 1110 | | +2.99268 V |
| 00 0000 0000 0001 | | +0.000366 V |
| 00 0000 0000 0000 | | 0 V |
| 11 1111 1111 1111 | | -0.000366 V |
| 10 0000 0000 0001 | | -2.999634 V |
| 10 0000 0000 0000 | | -3 V |

*Assuming REF IN = +3 V.

AD7242/AD7244

TIMING AND CONTROL

Communication with the AD7242/AD7244 is via six serial logic inputs. These consist of separate serial clocks, word framing and data lines for each DAC. DAC updating is controlled by two digital inputs: $\overline{\text{LDACA}}$ for updating V_{OUTA} and $\overline{\text{LDACB}}$ for updating V_{OUTB} . These inputs can be asserted independently of the microprocessor by an external timer when precise updating intervals are required. Alternatively, the $\overline{\text{LDACA}}$ and $\overline{\text{LDACB}}$ inputs can be driven from a decoded address bus allowing the microprocessor control over DAC updating as well as data communication to the AD7242/AD7244 input latches.

The AD7242/AD7244 contains two latches per DAC, an input latch and a DAC latch. Data must be loaded to the input latch under the control of TCLKA , $\overline{\text{TFSA}}$ and DTA for input Latch A and TCLKB , $\overline{\text{TFSB}}$ and DTB for input Latch B. Data is then transferred from input Latch A to DAC Latch A under the control of the $\overline{\text{LDACA}}$ signal, while $\overline{\text{LDACB}}$ controls the loading of DAC Latch B from input Latch B. Only the data held in the DAC latches determines the analog outputs of the AD7242/AD7244.

Data is loaded to the input latches under control of the respective TCLK , $\overline{\text{TFS}}$ and DT signals. The AD7242/AD7244 expects a 16-bit stream of serial data on its DT inputs. Data must be valid on the falling edge of TCLK . The $\overline{\text{TFS}}$ input provides the frame synchronization signal that tells the AD7242/AD7244 that valid serial data will be available on the DT input for the next 16 falling edges of TCLK . Figure 6 shows the

timing diagram for operation of either of the two serial input ports on the part.

Although 16 bits of data are clocked into the input latch, only 12 bits are transferred into the DAC latch for the AD7242 and 14 bits are transferred for the AD7244. Therefore, 4 bits in the AD7242 data stream and 2 bits in the AD7244 data stream are don't cares since their value does not affect the DAC latch data. The bit positions are the don't cares followed by the DAC data starting with the MSB (see Figure 6).

The respective $\overline{\text{LDAC}}$ signals control the transfer of data to the respective DAC latches. Normally, data is loaded to the DAC latch on the falling edge of $\overline{\text{LDAC}}$. However, if $\overline{\text{LDAC}}$ is held low, serial data is loaded to the DAC latch on the sixteenth falling edge of TCLK . If $\overline{\text{LDAC}}$ goes low during the loading of serial data to the input latch, no DAC latch update takes place on the falling edge of $\overline{\text{LDAC}}$. If $\overline{\text{LDAC}}$ stays low until the serial transfer is completed, then the update takes place on the sixteenth falling edge of TCLK . If $\overline{\text{LDAC}}$ returns high before the serial data transfer is completed, no DAC latch update takes place.

If seventeen or more TCLK edges occur while $\overline{\text{TFS}}$ is low, the seventeenth (and beyond) clock edges are ignored, i.e., no further data is clocked into the input latch after the sixteenth TCLK edge following a falling edge on $\overline{\text{TFS}}$.

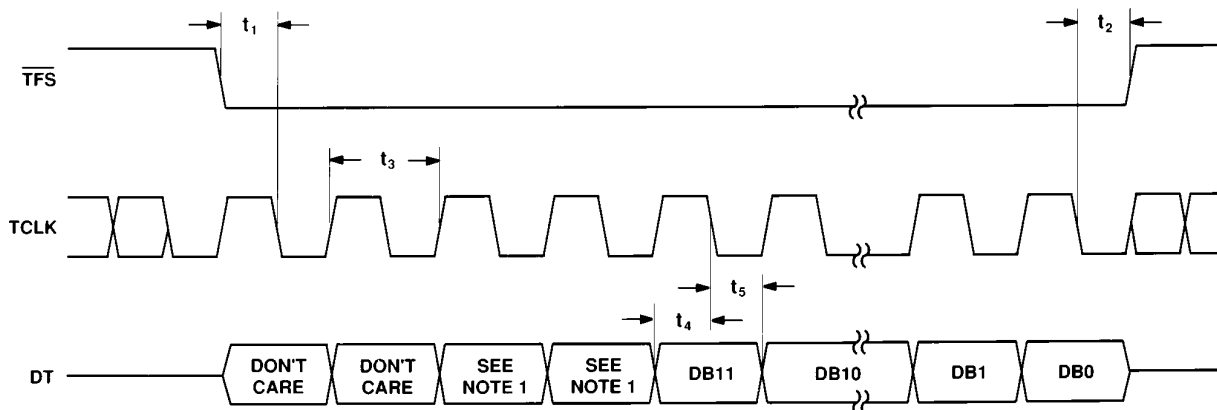

NOTE 1:
DON'T CARE FOR AD7242; DB12 AND DB13 FOR THE AD7244

Figure 6. AD7242/AD7244 Timing Diagram

MICROPROCESSOR INTERFACING

Microprocessor interfacing to the AD7242/AD7244 is via a serial bus that uses standard protocol compatible with DSP processors and microcontrollers. The communication interface consists of a separate transmit section for each of the DACs. Each section has a clock signal, a data signal and a frame or strobe pulse.

Figures 7 through 11 show the AD7242/AD7244 configured for interfacing to a number of popular DSP processors and microcontrollers.

AD7242/AD7244 to ADSP-2101/ADSP-2102 Interface

Figure 7 shows a serial interface between the AD7242/AD7244 and the ADSP-2101/ADSP-2102 DSP processor. The ADSP-2101/ADSP-2102 has two serial ports and, in the interface shown, both serial ports are used, one for each DAC. Both serial ports do not have to be used; in the case where only one serial port is used, an extra line ($\overline{\text{DACA}}/\overline{\text{DACB}}$ as shown in the other serial interfaces) would have to decode the one $\overline{\text{TFS}}$ line to provide $\overline{\text{TFSA}}$ and $\overline{\text{TFSB}}$ lines for the AD7242/AD7244.

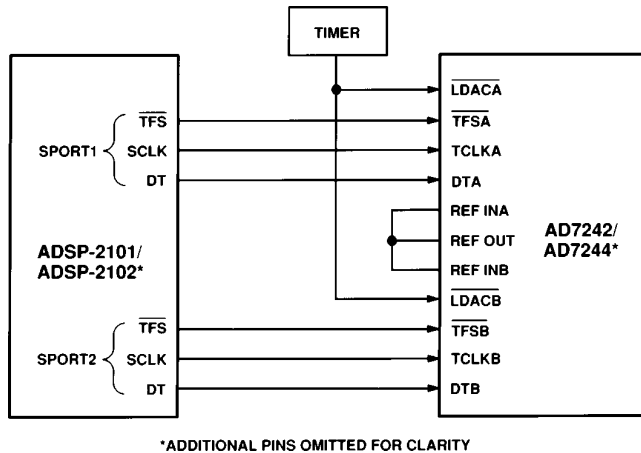

*ADDITIONAL PINS OMITTED FOR CLARITY

Figure 7. AD7242/AD7244 to ADSP-2101/ADSP-2102 Interface

The three serial lines of the first serial port, SPORT1, of the ADSP-2101/ADSP-2102 connect directly to the three serial input lines of $\overline{\text{DACA}}$ of the AD7242/AD7244. The three serial lines of SPORT2 connect directly to the three serial lines on the $\overline{\text{DACB}}$ serial input port. Data from the ADSP-2101/ADSP-2102 is valid on the falling edge of SCLK. A common LDAC signal is used to drive the $\overline{\text{LDACA}}$ and $\overline{\text{LDACB}}$ inputs. This is shown to be generated from a timer or clock recovery circuit but another

control or address line of the ADSP-2101/ADSP-2102 could be used to drive these inputs. Alternatively, the $\overline{\text{LDACA}}$ and $\overline{\text{LDACB}}$ inputs of the AD7242/AD7244 could be hardwired low; in this case the update of the DAC latches and analog outputs takes place on the 16th falling edge of SCLK (after the respective $\overline{\text{TFS}}$ signal goes low).

AD7242/AD7244 to DSP56000 Interface

A serial interface between the AD7242/AD7244 and the DSP56000 is shown in Figure 8. The DSP56000 is configured for normal mode, asynchronous operation with gated clock. It is also set up for a 16-bit word with SCK and SC2 as outputs and the FSL control bit set to a 0. SCK is internally generated on the DSP56000 and applied to both the TCLKA and TCLKB inputs of the AD7242/AD7244. Data from the DSP56000 is valid on the falling edge of SCK. The serial data line, STD drives the DTA and DTB serial input data lines of the AD7242/AD7244.

The SC2 output provides the framing pulse for valid data. This is an active high output and is gated with a $\overline{\text{DACA}}/\overline{\text{DACB}}$ control line before being applied to the $\overline{\text{TFSA}}$ and $\overline{\text{TFSB}}$ inputs of the AD7242/AD7244. The $\overline{\text{DACA}}/\overline{\text{DACB}}$ line determines which DAC serial data is to be transferred to, i.e., which TFS line is active when SC2 is active.

As in the previous interface, a common $\overline{\text{LDAC}}$ input is shown driving the $\overline{\text{LDACA}}$ and $\overline{\text{LDACB}}$ inputs of the AD7242/AD7244. Once again, these LDAC inputs could be hardwired low, in which case V_{OUTA} or V_{OUTB} will be updated on the sixteenth falling edge of SCK after the $\overline{\text{TFSA}}$ or $\overline{\text{TFSB}}$ input goes low.

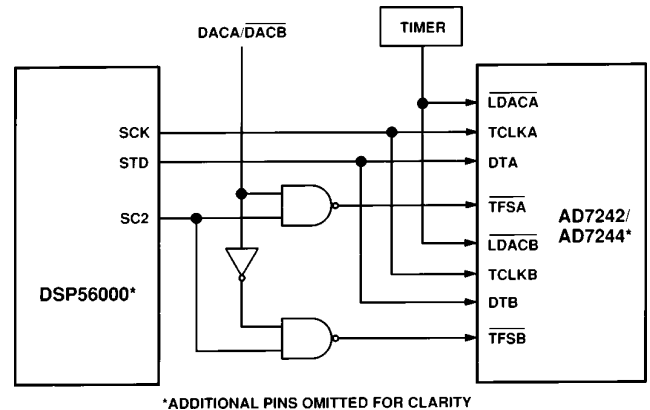

*ADDITIONAL PINS OMITTED FOR CLARITY

Figure 8. AD7242/AD7244 to DSP56000 Interface

AD7242/AD7244

AD7242/AD7244 to TMS320C25 Interface

Figure 9 shows a serial interface between the AD7242/AD7244 and the TMS320C25 DSP processor. In this interface, the CLKX and FSX signals of the TMS320C25 are generated from the clock/timer circuitry. The FSX pin of the TMS320C25 must be configured as an input. CLKX is used to provide both the TCLKA and TCLKB inputs of the AD7242/AD7244. DX of the TMS320C25 is also routed to the serial data line of each input port of the AD7242/AD7244.

Data from the TMS32020 is valid on the falling edge of CLKX after FSX goes low. This FSX signal is gated with the $\overline{\text{DACA}}$ / $\overline{\text{DACB}}$ control line to determine whether $\overline{\text{TFSA}}$ or $\overline{\text{TFSB}}$ goes low when FSX goes low.

The clock/timer circuitry also generates the $\overline{\text{LDAC}}$ signal for the AD7242/AD7244 to synchronize the update of the outputs with the serial transmission. As in the previous interface diagrams, a common $\overline{\text{LDAC}}$ input is shown driving the $\overline{\text{LDACA}}$ and $\overline{\text{LDACB}}$ inputs of the AD7242/AD7244. Once again, these $\overline{\text{LDAC}}$ inputs could be hardwired low, in which case V_{OUTA} or V_{OUTB} will be updated on the sixteenth falling edge of CLKX after the TFSA or TFSB input goes low.

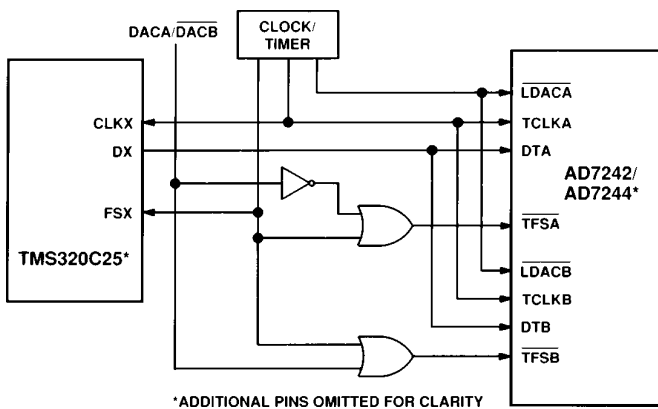

Figure 9. AD7242/AD7244 to TMS320C25 Interface

AD7242/AD7244 to 87C51 Interface

A serial interface between the AD7242/AD7244 and the 87C51 microcontroller is shown in Figure 10. TXD of the 87C51 drives TCLKA and TCLKB of the AD7242/AD7244 while RXD drives the two serial data lines of the part. The $\overline{\text{TFSA}}$ and $\overline{\text{TFSB}}$ signals are derived from P3.2 and P3.3, respectively.

The 87C51 provides the LSB of its SBUF register as the first bit in the serial data stream. Therefore, the user will have to ensure that the data in the SBUF register is correctly arranged so the don't care bits are the first to be transmitted to the AD7242/AD7244; the last bit to be sent is the LSB of the word to be loaded to the AD7242/AD7244. When data is to be transmitted to the part, P3.2 (for DACA) or P3.3 (for DACB) is taken low. Data on RXD is valid on the falling edge of TXD. The 87C51 transmits its serial data in 8-bit bytes with only eight falling clock edges occurring in the transmit cycle. To load data to the AD7242/AD7244, P3.2 (for DACA) or P3.3 (for DACB) is left low after the first eight bits are transferred and a second byte of data is then serially transferred to the AD7242/AD7244. When the second serial transfer is complete, the P3.2 line (for DACA) or the P3.3 line (for DACB) is taken high.

Figure 10 shows both $\overline{\text{LDAC}}$ inputs of the AD7242/AD7244 hardwired low. As a result, the DAC latch and the analog

output of one of the DACs will be updated on the sixteenth falling edge of TXD after the respective $\overline{\text{TFS}}$ signal for that DAC has gone low. Alternatively, the scheme used in previous interfaces, whereby the $\overline{\text{LDAC}}$ inputs are driven from a timer, can be used.

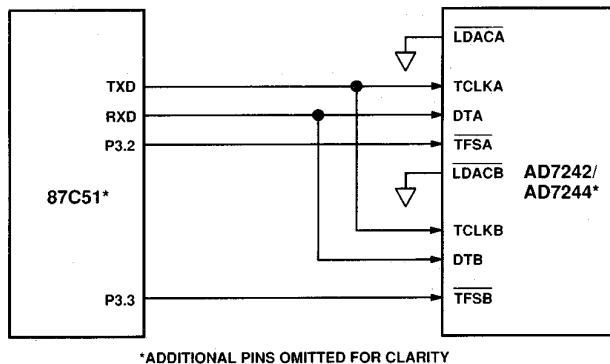

Figure 10. AD7242/AD7244 to 87C51 Interface

AD7242/AD7244 to 68HC11 Interface

Figure 11 shows a serial interface between the AD7242/AD7244 and the 68HC11 microcontroller. SCK of the 68HC11 drives TCLKA and TCLKB of the AD7242/AD7244 while the MOSI output drives the two serial data lines of the AD7242/AD7244. The $\overline{\text{TFSA}}$ and $\overline{\text{TFSB}}$ signals are derived from PC6 and PC7, respectively.

For correct operation of this interface, the 68HC11 should be configured such that its CPOL bit is a 0 and its CPHA bit is a 1. When data is to be transmitted to the part, PC6 (for DACA) or PC7 (for DACB) is taken low. When the 68HC11 is configured like this, data on MOSI is valid on the falling edge of SCK. The 68HC11 transmits its serial data in 8-bit bytes with only eight falling clock edges occurring in the transmit cycle. To load data to the AD7242/AD7244, PC6 (for DACA) or PC7 (for DACB) is left low after the first eight bits are transferred and a second byte of data is then serially transferred to the AD7242/AD7244. When the second serial transfer is complete, the PC6 line (for DACA) or the PC7 line (for DACB) is taken high.

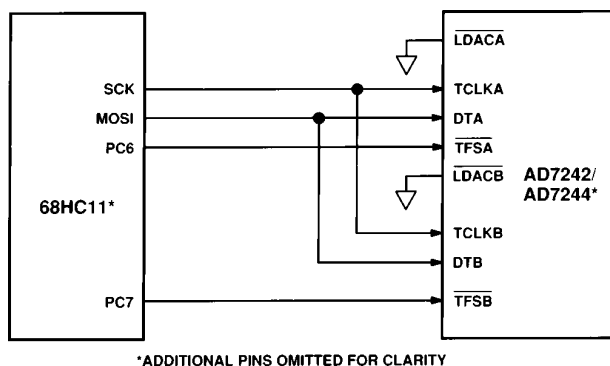

Figure 11. AD7242/AD7244 to 68HC11 Interface

Figure 11 shows both $\overline{\text{LDAC}}$ inputs of the AD7242/AD7244 hardwired low. As a result, the DAC latch and the analog output of one of the DACs will be updated on the sixteenth falling edge of SCK after the respective $\overline{\text{TFS}}$ signal for that DAC has gone low. Alternatively, the scheme used in previous interfaces, whereby the $\overline{\text{LDAC}}$ inputs are driven from a timer, can be used.

APPLYING THE AD7242/AD7244

Good printed circuit board layout is as important as the overall circuit design itself in achieving high speed converter performance. The AD7242 works on an LSB size of 1.465 mV, while the AD7244 works on an LSB size of 366 μ V. Therefore, the designer must be conscious of minimizing noise in both the converter itself and in the surrounding circuitry. Switching mode power supplies are not recommended as the switching spikes can feed through to the on-chip amplifier. Other causes of concern are ground loops and digital feedthrough from microprocessors. These are factors that influence any high performance converter, and a proper PCB layout that minimizes these effects is essential for best performance.

LAYOUT HINTS

Ensure that the layout for the printed circuit board has separated digital and analog lines as much as possible. Take care not to run any digital track alongside an analog signal track. Establish a single point analog ground (star ground) separate from the logic system ground. Place this star ground as close as possible to the AD7242/AD7244. Connect all analog grounds to this star ground and also connect the AD7242/AD7244 DGND pins to this ground. Do not connect any other digital grounds to this analog ground point.

Low impedance analog and digital power supply common returns are essential to low noise operation of high performance converters. Therefore, the foil width for these tracks should be kept as wide as possible. The use of ground planes minimizes impedance paths and also guards the analog circuitry from digital noise.

NOISE

Keep the signal leads on the V_{OUTA} and V_{OUTB} signals and the signal return leads to AGND as short as possible to minimize noise coupling. In applications where this is not possible, use a shielded cable between the DAC outputs and their destination. Reduce the ground circuit impedance as much as possible since any potential difference in grounds between the DAC and its destination device appears as an error voltage in series with the DAC output.

AD7242/AD7244

OUTLINE DIMENSIONS

Dimensions shown in inches and (mm).

Plastic DIP (N-24)



1. LEAD NO. 1 IDENTIFIED BY DOT OR NOTCH.
2. PLASTIC LEADS WILL BE EITHER SOLDER DIPPED OR TIN LEAD PLATED IN ACCORDANCE WITH MIL-M-38510 REQUIREMENTS.

Cerdip (Q-24)



1. LEAD NO. 1 IDENTIFIED BY DOT OR NOTCH.
2. CERDIP LEADS WILL BE EITHER TIN PLATED OR SOLDER DIPPED IN ACCORDANCE WITH MIL-M-38510 REQUIREMENTS.

SOIC (R-28)

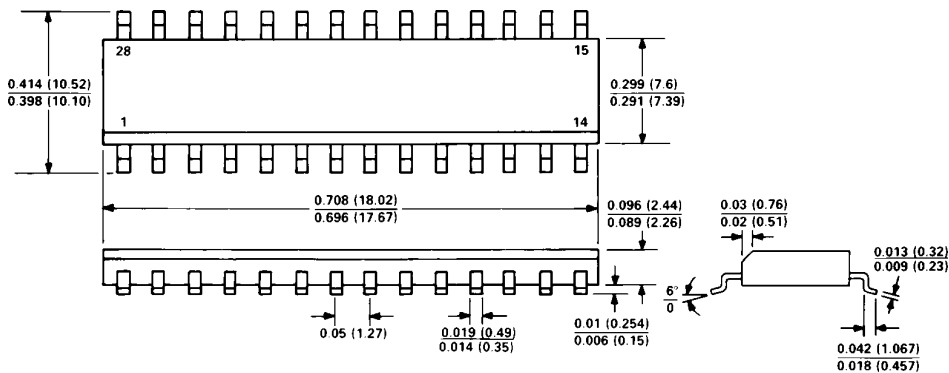

1. LEAD NO. 1 IDENTIFIED BY A DOT.
2. SOIC LEADS WILL BE EITHER TIN PLATED OR SOLDER DIPPED IN ACCORDANCE WITH MIL-M-38510 REQUIREMENTS.



Компания «ЭлектроПласт» предлагает заключение долгосрочных отношений при поставках импортных электронных компонентов на взаимовыгодных условиях!

Наши преимущества:

- Оперативные поставки широкого спектра электронных компонентов отечественного и импортного производства напрямую от производителей и с крупнейших мировых складов;
- Поставка более 17-ти миллионов наименований электронных компонентов;
- Поставка сложных, дефицитных, либо снятых с производства позиций;
- Оперативные сроки поставки под заказ (от 5 рабочих дней);
- Экспресс доставка в любую точку России;
- Техническая поддержка проекта, помощь в подборе аналогов, поставка прототипов;
- Система менеджмента качества сертифицирована по Международному стандарту ISO 9001;
- Лицензия ФСБ на осуществление работ с использованием сведений, составляющих государственную тайну;
- Поставка специализированных компонентов (Xilinx, Altera, Analog Devices, Intersil, Interpoint, Microsemi, Aeroflex, Peregrine, Syfer, Eurofarad, Texas Instrument, Miteq, Cobham, E2V, MA-COM, Hittite, Mini-Circuits, General Dynamics и др.);

Помимо этого, одним из направлений компании «ЭлектроПласт» является направление «Источники питания». Мы предлагаем Вам помощь Конструкторского отдела:

- Подбор оптимального решения, техническое обоснование при выборе компонента;
- Подбор аналогов;
- Консультации по применению компонента;
- Поставка образцов и прототипов;
- Техническая поддержка проекта;
- Защита от снятия компонента с производства.



Как с нами связаться

Телефон: 8 (812) 309 58 32 (многоканальный)

Факс: 8 (812) 320-02-42

Электронная почта: org@eplast1.ru

Адрес: 198099, г. Санкт-Петербург, ул. Калинина, дом 2, корпус 4, литера А.