

RF Power Barrel Capacitors with Screw Terminals, Class 1 and Class 2 Ceramic



QUICK REFERENCE DATA		
DESCRIPTION	VALUE	
Ceramic Class	1	2
Ceramic Dielectric	C0G, U2J, S3L	X7R
Type	TOS 030033	
Voltage (V _p)	15 000	15 000
Min. Capacitance (pF)	10	750
Max. Capacitance (pF)	500	1500
Mounting	Screw terminal	

MATERIAL

Capacitor elements made from class 1 ceramic dielectric with noble metal electrodes.

Connection terminals:
thread terminal, brass, silver plated.

Allowable torque: 2.9 Nm (26 lbf in)

FINISH

Capacitor body completely protective lacquered.

MARKING

Type designator, capacitance value and tolerance, rated peak voltage, ceramic material code, production date code, manufacturer logo.

FEATURES

- High voltage power rating
- Geometry minimizes inductance, optimizes voltage withstand and maximizes heat radiation

APPLICATIONS

- Industrial and medical RF power supply
- Filter, bypass and coupling circuits
- Antenna couplers
- Induction heating equipment

CAPACITANCE RANGE

10 pF to 1.5 nF

CAPACITANCE TOLERANCE

- Class 1: ± 10 %
- Class 2: ± 20 %

CERAMIC DIELECTRICS

- Class 1: C0G, U2J, S3L
- Class 2: X7R

RATED VOLTAGE

15 kV_{DC}

DIELECTRIC STRENGTH TEST

150 % of rated voltage (15 900 V_{RMS}, 50 Hz, 3 minutes)

DISSIPATION FACTOR

C0G, U2J: max. 0.05 % (1 MHz)

S3L: max. 0.20 % (1 MHz)

X7R: max. 2.5 % (1 kHz)

INSULATION RESISTANCE

Min. 100 000 MΩ (at 25 °C)

OPERATING TEMPERATURE RANGE

Class 1: -55 °C to +100 °C

Class 2: -55 °C to +85 °C

SAP PART NUMBER AND ELECTRICAL DATA									
PART NUMBER	CERAMIC	CAP. VALUES (pF)	RATED VOLTAGE (kV _{DC})	MAXIMUM POWER RATING ⁽¹⁾			MAXIMUM CURRENT RATING		
				1.0 MHz (kvar)	10 MHz (kvar)	30 MHz (kvar)	1.0 MHz (A _{RMS})	10 MHz (A _{RMS})	30 MHz (A _{RMS})
BS030033BJ10036AC1	C0G (NP0)	10	15	7.0	35	35	0.7	4.7	8.1
BS030033BJ25036AC1		25		18	35	35	1.7	7.4	13
BS030033BJ50036AC1		50		35	35	35	3.3	11	18
BS030033BJ75036AL1	U2J (N750)	75		35	35	35	4.1	13	22
BS030033BJ10136AL1		100		35	35	35	4.7	15	26
BS030033BJ15136AL1		150		22	22	22	4.6	14	25
BS030033BJ20136AL1		200		15	15	15	4.3	14	24
BS030033BJ30136AQ1	S3L (N3300)	300		5	5	5	3.1	10	17
BS030033BJ40136AQ1		400		5	5	5	3.6	11	19
BS030033BJ50136AQ1		500		5	5	5	4.0	13	22
BS030033BJ75138AV1	X7R (R2000)	750		0.5	0.5	0.5	1.5	5.0	8.4
BS030033BJ10238AV1		1000		0.5	0.5	0.5	1.8	6.0	9.7
BS030033BJ12238AV1		1200		0.5	0.5	0.5	2.0	6.0	12
BS030033BJ15238AV1		1500		0.5	0.5	0.5	2.2	6.0	12

Notes

- # 14th to 15th digit: capacitance tolerance code ± 10 % = 36; ± 20 % = 38
- Other capacitance values or metric threads are available on request
- ⁽¹⁾ The surface temperature during operation must not exceed +100 °C

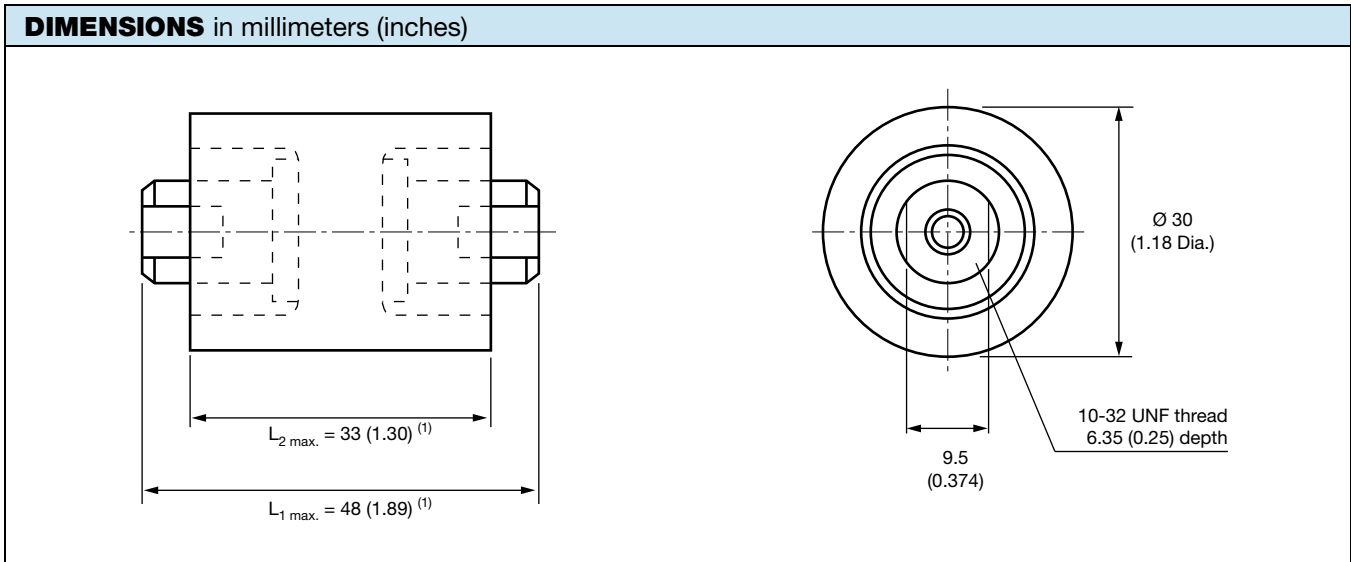
Notes

- Use wrenches when tightening the screws and nuts on both end of the capacitor
- ⁽¹⁾ Dimension L₁ and L₂ will vary depending upon capacitance value



Disclaimer

ALL PRODUCT, PRODUCT SPECIFICATIONS AND DATA ARE SUBJECT TO CHANGE WITHOUT NOTICE TO IMPROVE RELIABILITY, FUNCTION OR DESIGN OR OTHERWISE.

Vishay Intertechnology, Inc., its affiliates, agents, and employees, and all persons acting on its or their behalf (collectively, "Vishay"), disclaim any and all liability for any errors, inaccuracies or incompleteness contained in any datasheet or in any other disclosure relating to any product.

Vishay makes no warranty, representation or guarantee regarding the suitability of the products for any particular purpose or the continuing production of any product. To the maximum extent permitted by applicable law, Vishay disclaims (i) any and all liability arising out of the application or use of any product, (ii) any and all liability, including without limitation special, consequential or incidental damages, and (iii) any and all implied warranties, including warranties of fitness for particular purpose, non-infringement and merchantability.

Statements regarding the suitability of products for certain types of applications are based on Vishay's knowledge of typical requirements that are often placed on Vishay products in generic applications. Such statements are not binding statements about the suitability of products for a particular application. It is the customer's responsibility to validate that a particular product with the properties described in the product specification is suitable for use in a particular application. Parameters provided in datasheets and/or specifications may vary in different applications and performance may vary over time. All operating parameters, including typical parameters, must be validated for each customer application by the customer's technical experts. Product specifications do not expand or otherwise modify Vishay's terms and conditions of purchase, including but not limited to the warranty expressed therein.

Except as expressly indicated in writing, Vishay products are not designed for use in medical, life-saving, or life-sustaining applications or for any other application in which the failure of the Vishay product could result in personal injury or death. Customers using or selling Vishay products not expressly indicated for use in such applications do so at their own risk. Please contact authorized Vishay personnel to obtain written terms and conditions regarding products designed for such applications.

No license, express or implied, by estoppel or otherwise, to any intellectual property rights is granted by this document or by any conduct of Vishay. Product names and markings noted herein may be trademarks of their respective owners.

Material Category Policy

Vishay Intertechnology, Inc. hereby certifies that all its products that are identified as RoHS-Compliant fulfill the definitions and restrictions defined under Directive 2011/65/EU of The European Parliament and of the Council of June 8, 2011 on the restriction of the use of certain hazardous substances in electrical and electronic equipment (EEE) - recast, unless otherwise specified as non-compliant.

Please note that some Vishay documentation may still make reference to RoHS Directive 2002/95/EC. We confirm that all the products identified as being compliant to Directive 2002/95/EC conform to Directive 2011/65/EU.

Vishay Intertechnology, Inc. hereby certifies that all its products that are identified as Halogen-Free follow Halogen-Free requirements as per JEDEC JS709A standards. Please note that some Vishay documentation may still make reference to the IEC 61249-2-21 definition. We confirm that all the products identified as being compliant to IEC 61249-2-21 conform to JEDEC JS709A standards.



Компания «ЭлектроПласт» предлагает заключение долгосрочных отношений при поставках импортных электронных компонентов на взаимовыгодных условиях!

Наши преимущества:

- Оперативные поставки широкого спектра электронных компонентов отечественного и импортного производства напрямую от производителей и с крупнейших мировых складов;
- Поставка более 17-ти миллионов наименований электронных компонентов;
- Поставка сложных, дефицитных, либо снятых с производства позиций;
- Оперативные сроки поставки под заказ (от 5 рабочих дней);
- Экспресс доставка в любую точку России;
- Техническая поддержка проекта, помощь в подборе аналогов, поставка прототипов;
- Система менеджмента качества сертифицирована по Международному стандарту ISO 9001;
- Лицензия ФСБ на осуществление работ с использованием сведений, составляющих государственную тайну;
- Поставка специализированных компонентов (Xilinx, Altera, Analog Devices, Intersil, Interpoint, Microsemi, Aeroflex, Peregrine, Syfer, Eurofarad, Texas Instrument, Miteq, Cobham, E2V, MA-COM, Hittite, Mini-Circuits, General Dynamics и др.);

Помимо этого, одним из направлений компании «ЭлектроПласт» является направление «Источники питания». Мы предлагаем Вам помощь Конструкторского отдела:

- Подбор оптимального решения, техническое обоснование при выборе компонента;
- Подбор аналогов;
- Консультации по применению компонента;
- Поставка образцов и прототипов;
- Техническая поддержка проекта;
- Защита от снятия компонента с производства.



Как с нами связаться

Телефон: 8 (812) 309 58 32 (многоканальный)

Факс: 8 (812) 320-02-42

Электронная почта: org@eplast1.ru

Адрес: 198099, г. Санкт-Петербург, ул. Калинина, дом 2, корпус 4, литера А.