

LPS200-M Series

250 Watts

Data Sheet

Total Power: 125 - 250 Watts
Input Voltage: 90 - 264 Vac
of Outputs: Single



SPECIAL FEATURES

- Medical and ITE safeties
- Active power factor correction
- 3" x 5" footprint
- Less than 1U high
- EN61000-3-2 compliant
- Remote sense
- Power fail
- Adjustable main output
- Built-in Class B EMI filter
- Overvoltage protection
- Overload protection
- Thermal overload protection
- Isolated 12 V Fan output
- LPX200 enclosure kit available
- RoHS compliant

SAFETY

- TUV 62368, 60601-1
- UL 62368, 60601-1
- cULus 62368, 60601-1
- CB Certificate & report
- CE Mark (LVD)

Electrical Specifications

Input	
Input range	90 - 264 Vac; 120 - 300 Vdc
Frequency	47 - 63 Hz
Inrush current	50 A max., cold start @ 25 °C
Efficiency	86% typical at full load
EMI/RFI	FCC Class B conducted; CISPR22 Class B conducted; EN55022 Class B conducted; VDE0878PT3 Class B conducted
Power factor	0.99 typical
Safety ground leakage current	275 µA @ 50/60 Hz, 264 Vac input
Output	
Maximum power	125 W for convection (100 W for LPS202-M); 250 W (200 W for LPS202-M) with 30CFM forced air
Adjustment range	± 10% minimum on the main outputs
Fan output	12 V @ 0.5 A convection, @ 1 A forced air isolated, ± 10%
Hold-up time	16 ms @ 250 W load, 120 Vac input
Overload protection	Short circuit protection on all outputs. Case overload protected @ 110 - 160% above rating
Overvoltage protection	15 - 50% above nominal output
Logical Control	
Power failure	Open collector logic signal goes high 100 - 500 msec after main output; it goes low at least 6 msec before loss of regulation
Remote sense	Compensates for 0.5 V lead drop min. Will operate without remote sense connected. Reverse connection protected.

Environmental Specifications

Operating temperature	0 °C to 50 °C ambient derate each output as 2.5% per degree from 50° to 70 °C. -20 °C start up
Storage temperature	-40 °C to +85 °C
Electromagnetic susceptibility	Designed to meet EN61000-4; -2, -3, -4, -5, -6, -8, -11 Level 3
Humidity	Operating; non-condensing 10% to 95% RH
Vibration	IEC68-2-6 to the levels of IEC721-3-2
MTBF calculated	1 million hours at full load and 25 °C ambient conditions. 230 Vac input, Bellcore

Ordering Information

Model Number	Output Voltage	Minimum Load	Maximum Load with Convection Cooling	Maximum Load with 30CFM Forced Air	Peak Load	Regulation ²	Ripple P/P (PARD) ³
LPS202-M	5 V	0 A	20 A	40 A	44 A	± 2%	50 mV
LPS203-M	12 V	0 A	10.3 A	20.8 A	22 A	± 2%	120 mV
LPS204-M	15 V	0 A	8.3 A	16.6 A	18 A	± 2%	150 mV
LPS205-M	24 V	0 A	5.2 A	10.4 A	11.5 A	± 2%	240 mV
LPS208-M	48 V	0 A	2.6 A	5.2 A	5.8 A	± 2%	480 mV

1. Peak current lasting <30 seconds with a maximum 10% duty cycle.
2. At 25 °C including initial tolerance, line voltage, load currents and output voltages adjusted to factory settings.
3. Peak-to-peak with 20 MHz bandwidth and 10 µF (tantalum capacitor) in parallel with a 0.1 µF capacitor at rated line voltage and load ranges.
4. This product is a Component Power Supply and is only for inclusion by professional installers within other equipment and must not be operated as a standalone product. EMC compliance to appropriate standards must be verified at the system level. This product is for sale to OEMs and System Integrators, including through Distribution Channels. It is not intended for sale to End Users.

Pin Assignments

Connector	LPS200-M	
SK1	Pin 1	Neutral
	Pin 3	Line
SK2	TB-1	Common
	TB-2	Main output
SK3	Pin 1	+V1 Remote sense
	Pin 2	-V1 Remote sense
	Pin 3	N/C
	Pin 4	N/C
	Pin 5	+Power fail
	Pin 6	Common
	Pin 7	N/C
	Pin 8	Common
	Pin 9	+12 V Fan
	Pin 10	+12 Fan Return (isolated)

Mating Connectors

AC Input (SK1)	Molex 09-50-8031 (connector) PINS: 08-52-0072
AC Ground	Molex 01-90020001
DC Output (SK2)	Molex 19141-0058 or 19099-0044 Spade lug based on Cable Ampacity/AWG
Control Sense (SK3)	Molex 90142-1110 (USA) PINS: 90119-2110 or Amp: 87977-3 PINS: 87309-8 or Landwin: 2580S1003 PINS: 2583T021V
Artesyn Embedded Power Connector Kit #70-841-020, includes all of the above.	

1. Specifications subject to change without notice.
2. All dimensions in inches (mm), tolerance is ± 0.02" (± 0.5 mm)
3. Mounting holes MH1 and MH2 should be grounded for EMI purposes.
4. Mounting hole MH1 is safety ground connection.
5. Specifications are for convection rating at factory settings at 115 VAC input, 25 °C unless otherwise stated.
6. This power supply requires mounting on metal standoffs 0.20" (5m) in height.
7. Warranty: 2 years
8. Weight: 0.75 lb/0.34 kg

Mechanical Drawing

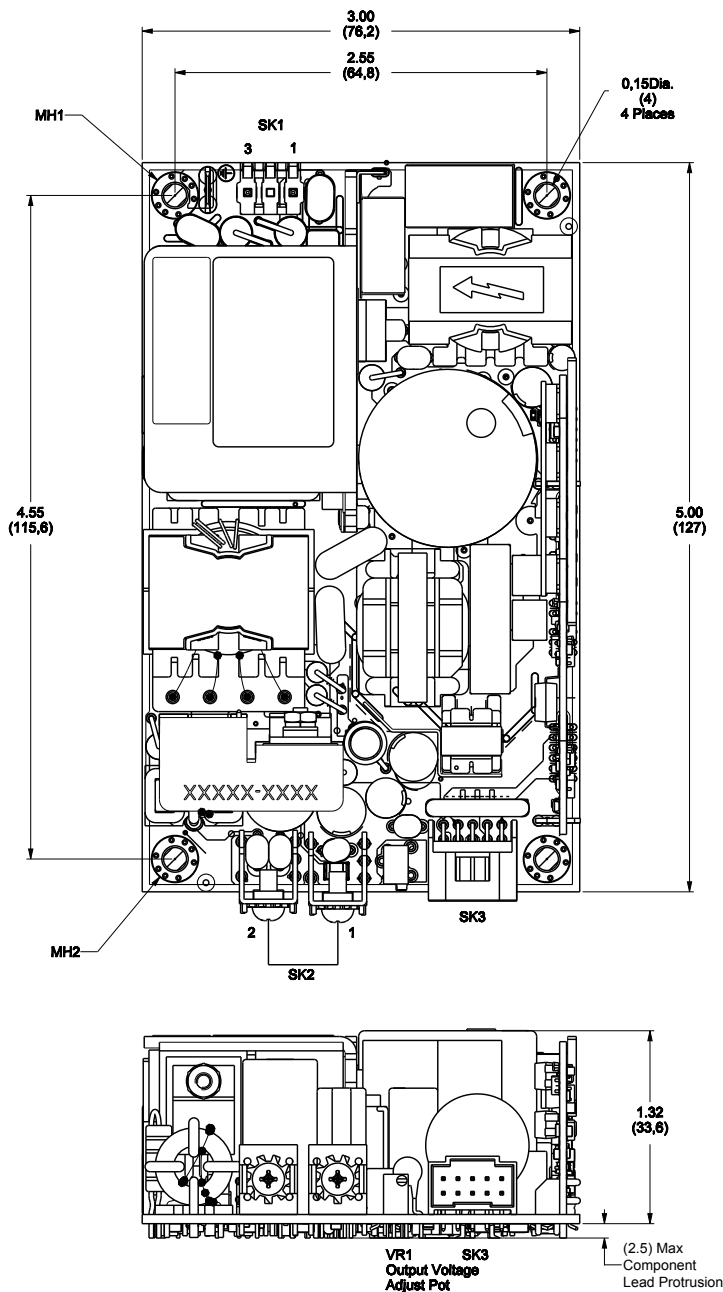

WORLDWIDE OFFICES

Americas

2900 South Diablo Way
Suite B100
Tempe, AZ 85282, USA
+1 888 412 7832

Europe (UK)

Ground Floor Offices, Barberry House
4 Harbour Buildings, Waterfront West
Brierley Hill, West Midlands
DY5 1LN, UK
+44 (0) 1384 842 211

Asia (HK)

14/F, Lu Plaza
2 Wing Yip Street
Kwun Tong, Kowloon
Hong Kong
+852 2176 3333

ARTESYNTM
An Advanced Energy Company

www.artesyn.com

Artesyn Embedded Technologies, Artesyn Embedded Power, Artesyn, and all Artesyn related logos are trademarks and service marks of Artesyn Embedded Technologies, Inc. All other names and logos referred to are trade names, trademarks, or registered trademarks of their respective owners. Specifications are subject to change without notice. © 2020 Artesyn Embedded Technologies, Inc. All rights reserved. For full legal terms and conditions, please visit www.artesyn.com/legal.

For more information: www.artesyn.com
For support: productsupport.ep@artesyn.com



Компания «ЭлектроПласт» предлагает заключение долгосрочных отношений при поставках импортных электронных компонентов на взаимовыгодных условиях!

Наши преимущества:

- Оперативные поставки широкого спектра электронных компонентов отечественного и импортного производства напрямую от производителей и с крупнейших мировых складов;
- Поставка более 17-ти миллионов наименований электронных компонентов;
- Поставка сложных, дефицитных, либо снятых с производства позиций;
- Оперативные сроки поставки под заказ (от 5 рабочих дней);
- Экспресс доставка в любую точку России;
- Техническая поддержка проекта, помощь в подборе аналогов, поставка прототипов;
- Система менеджмента качества сертифицирована по Международному стандарту ISO 9001;
- Лицензия ФСБ на осуществление работ с использованием сведений, составляющих государственную тайну;
- Поставка специализированных компонентов (Xilinx, Altera, Analog Devices, Intersil, Interpoint, Microsemi, Aeroflex, Peregrine, Syfer, Eurofarad, Texas Instrument, Miteq, Cobham, E2V, MA-COM, Hittite, Mini-Circuits, General Dynamics и др.);

Помимо этого, одним из направлений компании «ЭлектроПласт» является направление «Источники питания». Мы предлагаем Вам помощь Конструкторского отдела:

- Подбор оптимального решения, техническое обоснование при выборе компонента;
- Подбор аналогов;
- Консультации по применению компонента;
- Поставка образцов и прототипов;
- Техническая поддержка проекта;
- Защита от снятия компонента с производства.



Как с нами связаться

Телефон: 8 (812) 309 58 32 (многоканальный)

Факс: 8 (812) 320-02-42

Электронная почта: org@eplast1.ru

Адрес: 198099, г. Санкт-Петербург, ул. Калинина, дом 2, корпус 4, литера А.