

ALL DIMENSIONS ARE FOR REFERENCE ONLY.

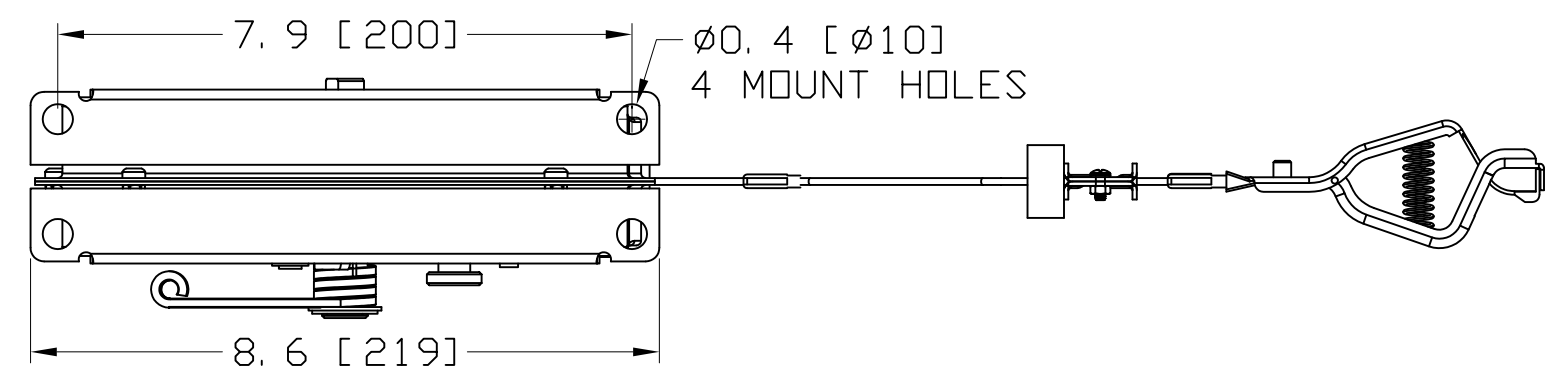
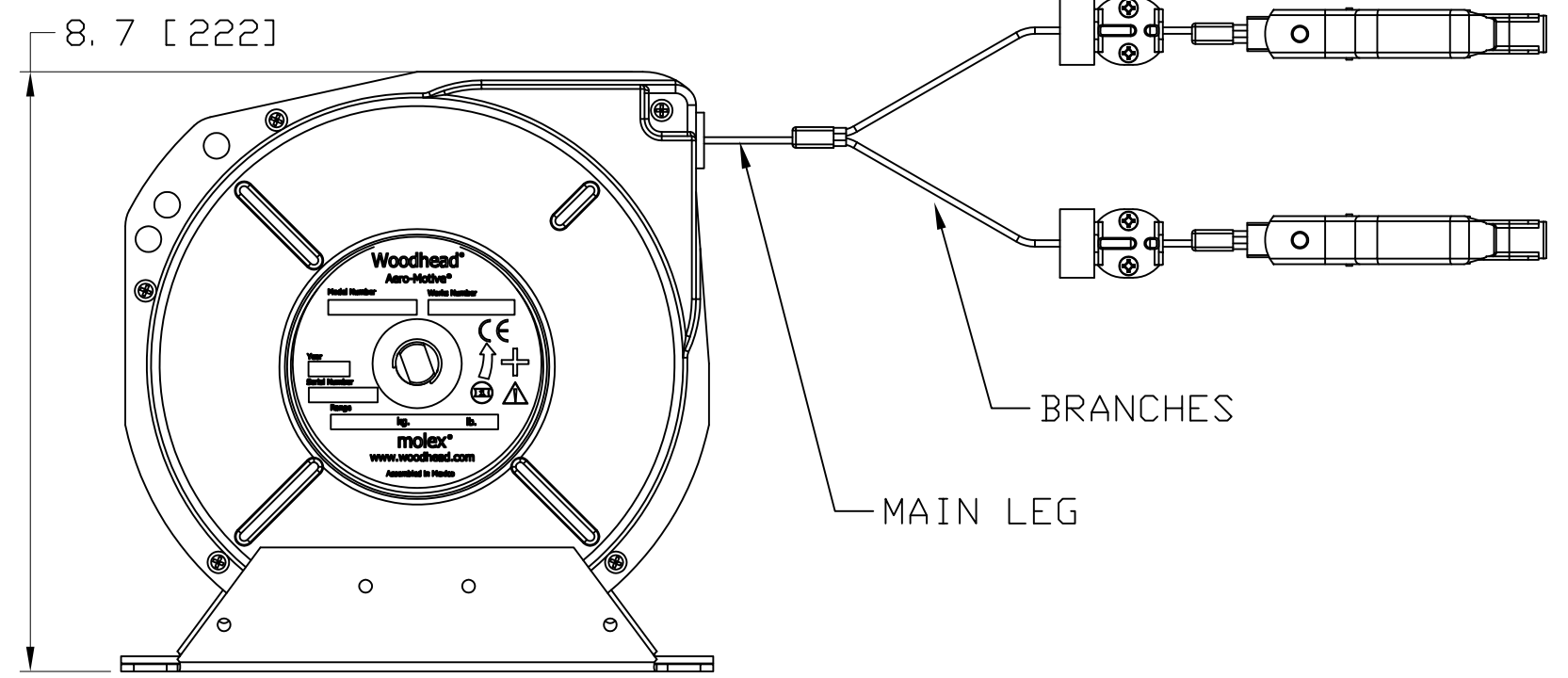
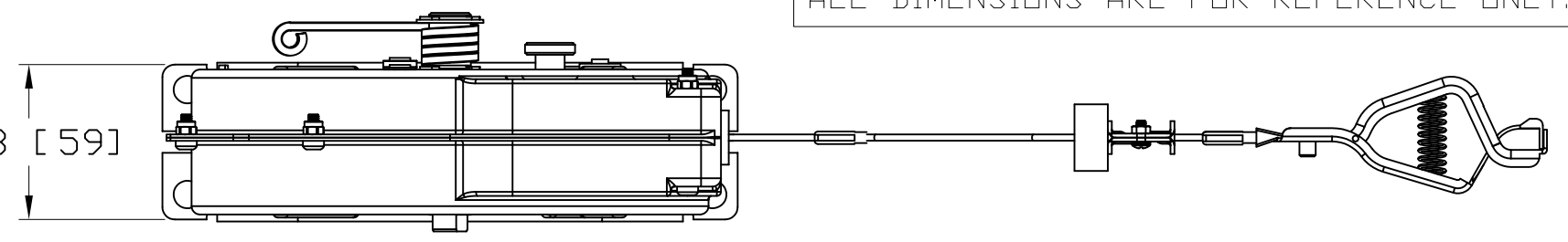
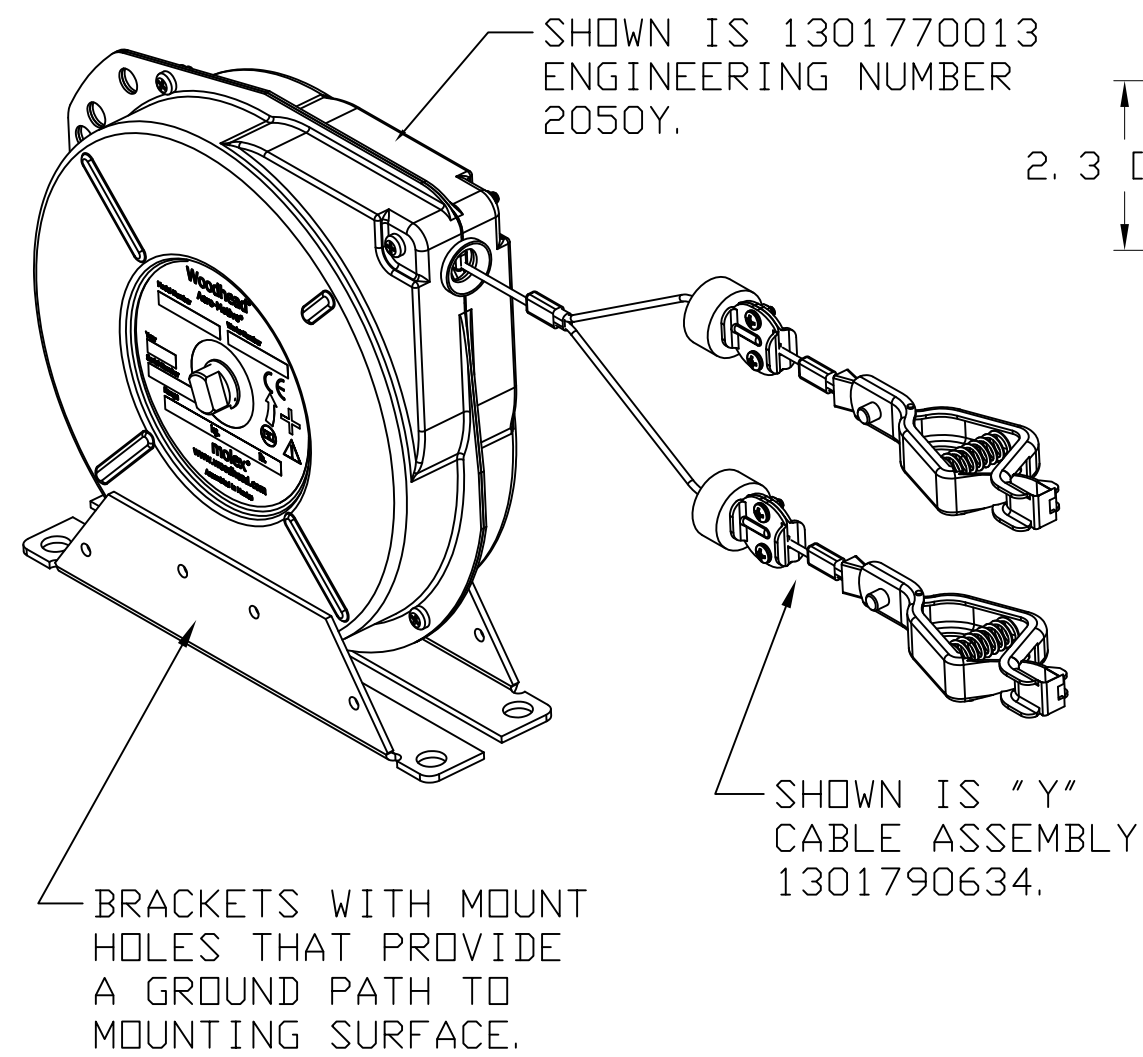

- NOTES:
1. STATIC REELS ARE 100% INSPECTED & PRE-TENSIONED AT FACTORY.
  2. HOUSINGS ARE MADE OF STEEL WITH POWDER COATING TO MEET HARSH INDUSTRIAL ENVIRONMENTS.
  3. ALWAYS READ INSTRUCTIONS MANUAL BEFORE USING STATIC REELS.
  4. STATIC REELS PROVIDE LIGHT, CONSTANT SPRING TENSION ON CABLE.
  5. STATIC REELS ARE EQUIPPED WITH 100A GROUND CLAMP.
  6. STATIC REELS HAVE MOUNTING BRACKETS WITH MOUNTING HOLES. WHEN MOUNTING THESE MAKE SURE THAT A GROUND PATH IS AVAILABLE FOR STATIC DISCHARGE.
  7. STATIC REELS HAVE THE OPTION OF HAVING A "Y" BRIDLE CABLE ASSEMBLY WITH 2 GROUNDING CLAMPS THAT ALLOW SIMULTANEOUS GROUNDING AT TWO POINTS.
  8. STATIC REELS WITH "Y" BRIDLE CABLE ASSEMBLY HAVE A 30FT[9.1M] PAYOUT FOR MAIN LEG & ANOTHER 20FT[6.1M] FOR EACH OF THE BRIDLE'S BRANCHES.

RELEASE TO GSM EC NO: WNA2011-0031 DRWN: RHOTCA 2010/08/04 CHKD: DT APPR: DTTITUS 2010/08/23	DESCRIPTION REV	<b>QUALITY SYMBOLS</b> ▽=0 ▽=0	<b>GENERAL TOLERANCES (UNLESS SPECIFIED)</b>		DIMENSION STYLE IN/MM		SCALE NTS	DESIGN UNITS INCH	THIRD ANGLE PROJECTION	
		4 PLACES ±    ± 3 PLACES ±    ± 2 PLACES ±    ± 1 PLACE ±    ±	mm    INCH	DRAWN BY RHOTCA	DATE 2010/08/04	TITLE 2050 SERIES STATIC REELS SALES DRAWING				
		ANGULAR ±1°		CHECKED BY DT	DATE 2010/08/04	MOLEX INCORPORATED				
		DRAFT WHERE APPLICABLE MUST REMAIN WITHIN DIMENSIONS		APPROVED BY DTTITUS	DATE 2010/08/18	MATERIAL NO. SEE TABLE	DOCUMENT NO. SD-130177-001	SHEET NO. 1 OF 3		
THIS DRAWING CONTAINS INFORMATION THAT IS PROPRIETARY TO MOLEX INCORPORATED AND SHOULD NOT BE USED WITHOUT WRITTEN PERMISSION										

ITEM:	MATERIAL NUMBER:	ENGINEERING NUMBER:	DESCRIPTION:
1	1301794791	9709-545	DRUM & SPRING ASSY FOR 1025/2050 REELS
2	1301790623	9685-4-1	9685-4 STATIC REEL HSNG - POWDER BLUE
3	1302263656	H22520009	MAIN HOUSING ASSEMBLY-LOCK SIDE
4	1301790120	9674-2	SCROLL LOCK LEVER KIT
5	1302344702	9816-2	CAM ZINC PLATED FOR 10FLR
6	1301790129	9733	NYLON WASHER
7	1301790132	9808	SCROLL LOCK RELEASE KNOB
8	1302344673	14099	WASHER -.63 I.D.x.88 O.D.x.02 W - BZP
9	1302344666	13613	GUIDE - CABLE OUTLET
10	1301790092	580-P-30	EXTERNAL CIRCLIP 0.375" SHAFT
11	1302344691	9611-1	MAIN SHAFT SPACER FOR 10F/15F/22F
12	1302344692	9616UK	TENSION LOCK SPRING FOR 10F/15F/22F
13	1302344704	AG10310	RET RING-ANDERTON N1500-62:BZP
14	1301790170	AG18769	SHIM WASHER 16mmODx10mmIDx0.5mmTK
15	1301790170	9813	SHIM WASHER 16mmODx10mmIDx0.5mmTK
16	SEE CHART	SEE CHART	SEE PART NUMBER TABLE FOR USAGE
17	1302344710	AG14612	SCREW M4X10LG Posi PHEAD BZP
18	1302344712	AG14614	SCREW M4X45 LG Posi PHEAD BZP
19	1302344713	AG14615	M4 NYLOC NUT
20	1301790632	651-P-10	CLAMP GROUND FOR 1025 STATIC REELS
21	1302344690	580-P-35	EXTERNAL CIRCLIP 0.625" SHAFT
22	1302344724	AG18723	M4 WHIZZ NUT SERRATED
23	N/A	M1306012X	LABEL IS NOT FOR RESALE PURPOSES.

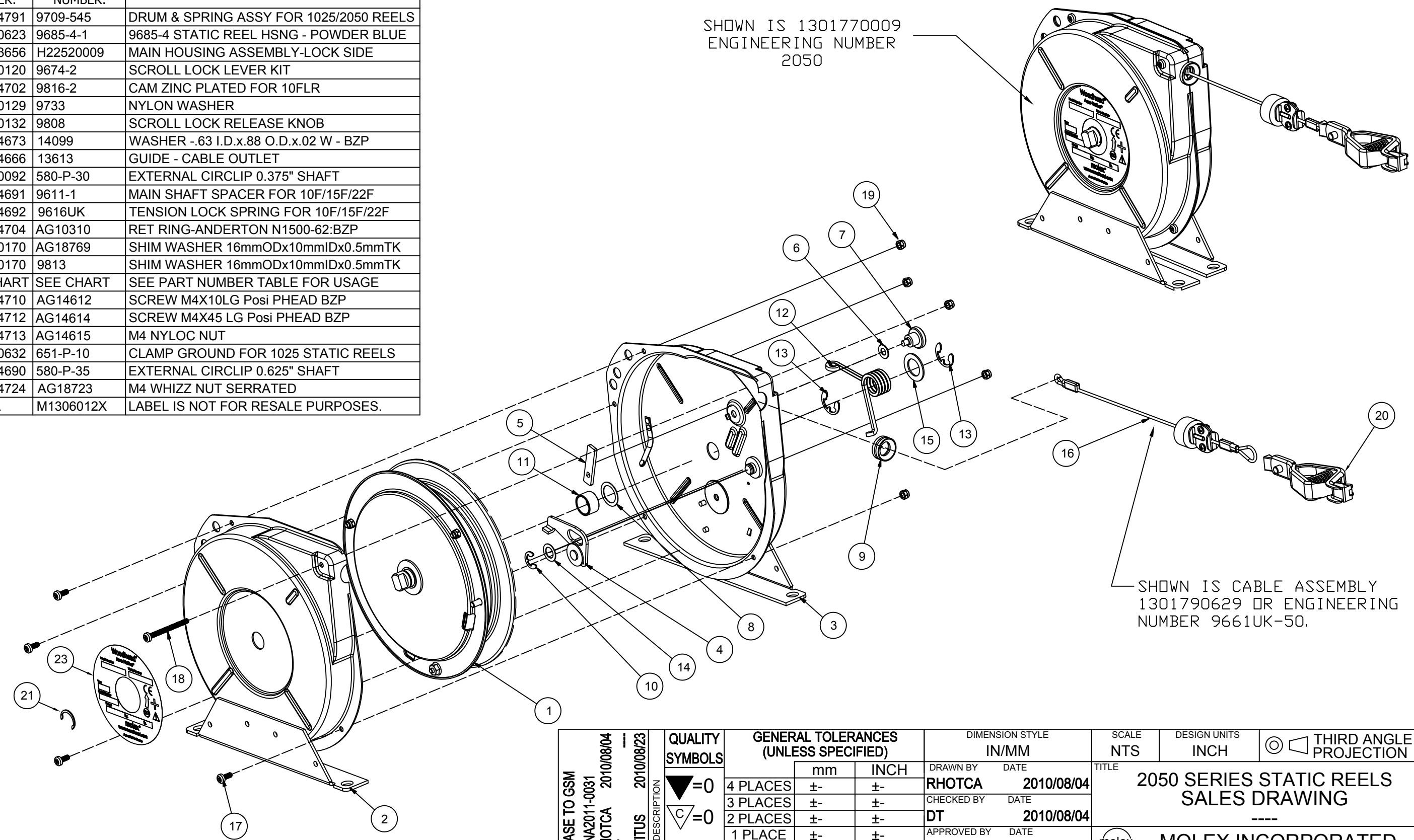

RELEASE TO GSM EC NO: WNA2011-0031 DRWN: RHOTCA 2010/08/04 CHKD: DT APPR: DITITUS 2010/08/23 DESCRIPTION REV	QUALITY SYMBOLS	GENERAL TOLERANCES (UNLESS SPECIFIED)		DIMENSION STYLE IN/MM		SCALE NTS	DESIGN UNITS INCH	THIRD ANGLE PROJECTION
	$\nabla=0$ $\triangle=0$	4 PLACES	mm	INCH	DRAWN BY	DATE	TITLE	
		3 PLACES	±	±	RHOTCA	2010/08/04	2050 SERIES STATIC REELS SALES DRAWING	
		2 PLACES	±	±	DT	2010/08/04	---	
	1 PLACE	±	±	APPROVED BY	DATE	MOLEX INCORPORATED		
		ANGULAR ±1°		DTITUS	2010/08/18	SD-130177-001		
		DRAFT WHERE APPLICABLE MUST REMAIN WITHIN DIMENSIONS		MATERIAL NO. SEE TABLE		DOCUMENT NO.	SHEET NO. 2 OF 3	
				SIZE B		THIS DRAWING CONTAINS INFORMATION THAT IS PROPRIETARY TO MOLEX INCORPORATED AND SHOULD NOT BE USED WITHOUT WRITTEN PERMISSION		

10 9 8 7 6 5 4 3 2 1

Material Number:	Engineering Number:	Description:	Weight Range in (KG):	Cable Travel in (M):	Weight Range in (LB):	Cable Travel in (FT):	USES CABLE ASSY:		"R" OHMS:	Color:
							MATERIAL NUMBER	ENGINEERING NUMBER		
1301770009	2050	STATIC REEL [12LB/5.44KG] - 50FT[15.3M]	5.44	15.3	12	50	1301790629	9661UK-50	2	BLUE
1301770011	2050NC	2050 REEL [12LB/5.44KG] W/NYLON CABLE	5.44	15.3	12	50	1301790690	9719UK-50	2	BLUE
1301770013	2050Y	STATIC REEL Y [12LB/5.44KG]-50FT[15.3M]	5.44	15.3	12	30 + 20	1301790634	41071UK-3	2	BLUE
1301770011	143050	STATIC REEL W/CABLE ASSY - 50FT[15.3M]	5.44	15.3	12	50	1301790629	9661UK-50	2	BLUE
1301770006	143050NC	143050 W/NYLON CABLE ASSY - 50FT[15.3M]	5.44	15.3	12	50	1301790690	9719UK-50	2	BLUE
1301770008	143051	STATIC REEL Y[12LB/5.44KG] - 50FT[15.3M]	5.44	15.3	12	30 + 20	1301790634	41071UK-3	2	BLUE

D  
C  
B

RELEASE TO GSM EC NO: WNA2011-0031 DRWN: RHOTCA 2010/08/04 CHKD: DT APPR: DITUS 2010/08/23	DESCRIPTION REV	QUALITY SYMBOLS	GENERAL TOLERANCES (UNLESS SPECIFIED)		DIMENSION STYLE		SCALE	DESIGN UNITS	THIRD ANGLE PROJECTION			
		 	mm	INCH	IN/MM	NTS	INCH	2050 SERIES STATIC REELS SALES DRAWING ---- MOLEX INCORPORATED				
		4 PLACES ±- ±- 3 PLACES ±- ±- 2 PLACES ±- ±- 1 PLACE ±- ±-	ANGULAR ±1°		DRAWN BY: RHOTCA DATE: 2010/08/04 CHECKED BY: DT DATE: 2010/08/04 APPROVED BY: DITUS DATE: 2010/08/18	TITLE: 2050 SERIES STATIC REELS SALES DRAWING MATERIAL NO.: SEE TABLE DOCUMENT NO.: SD-130177-001 SHEET NO.: 3 OF 3						
		DRAFT WHERE APPLICABLE MUST REMAIN WITHIN DIMENSIONS		SIZE B		THIS DRAWING CONTAINS INFORMATION THAT IS PROPRIETARY TO MOLEX INCORPORATED AND SHOULD NOT BE USED WITHOUT WRITTEN PERMISSION						

10 9 8 7 6 5 4 3 2 1



Компания «ЭлектроПласт» предлагает заключение долгосрочных отношений при поставках импортных электронных компонентов на взаимовыгодных условиях!

Наши преимущества:

- Оперативные поставки широкого спектра электронных компонентов отечественного и импортного производства напрямую от производителей и с крупнейших мировых складов;
- Поставка более 17-ти миллионов наименований электронных компонентов;
- Поставка сложных, дефицитных, либо снятых с производства позиций;
- Оперативные сроки поставки под заказ (от 5 рабочих дней);
- Экспресс доставка в любую точку России;
- Техническая поддержка проекта, помощь в подборе аналогов, поставка прототипов;
- Система менеджмента качества сертифицирована по Международному стандарту ISO 9001;
- Лицензия ФСБ на осуществление работ с использованием сведений, составляющих государственную тайну;
- Поставка специализированных компонентов (Xilinx, Altera, Analog Devices, Intersil, Interpoint, Microsemi, Aeroflex, Peregrine, Syfer, Eurofarad, Texas Instrument, Miteq, Cobham, E2V, MA-COM, Hittite, Mini-Circuits, General Dynamics и др.);

Помимо этого, одним из направлений компании «ЭлектроПласт» является направление «Источники питания». Мы предлагаем Вам помощь Конструкторского отдела:

- Подбор оптимального решения, техническое обоснование при выборе компонента;
- Подбор аналогов;
- Консультации по применению компонента;
- Поставка образцов и прототипов;
- Техническая поддержка проекта;
- Защита от снятия компонента с производства.



#### Как с нами связаться

**Телефон:** 8 (812) 309 58 32 (многоканальный)

**Факс:** 8 (812) 320-02-42

**Электронная почта:** [org@eplast1.ru](mailto:org@eplast1.ru)

**Адрес:** 198099, г. Санкт-Петербург, ул. Калинина, дом 2, корпус 4, литера А.