

REVISIONS			
REV	DESCRIPTION, ECN, EAR NO.	DATE	APP'D
A	PROPOSAL	APR01/17	L.CHAN

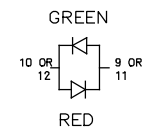

BI-COLOUR LED DETAIL
(YELLOW/GREEN, RED/YELLOW AND GREEN/ORANGE LED'S ARE ALSO AVAILABLE)

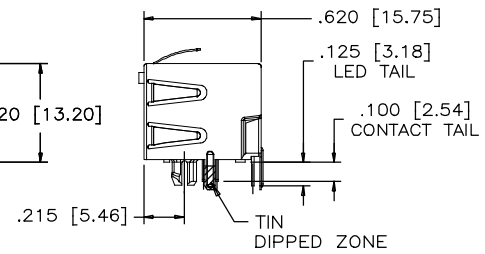
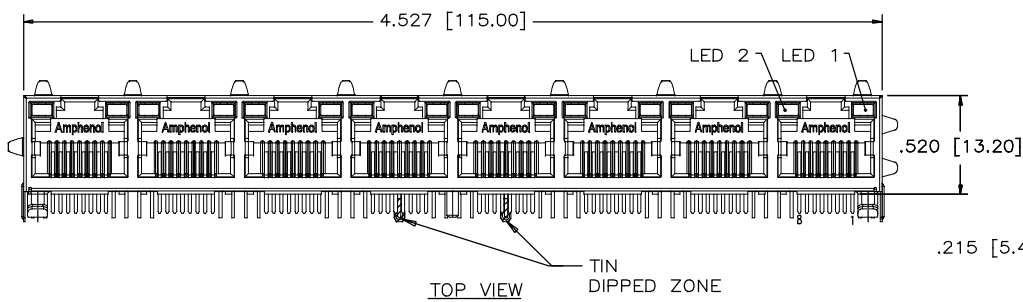
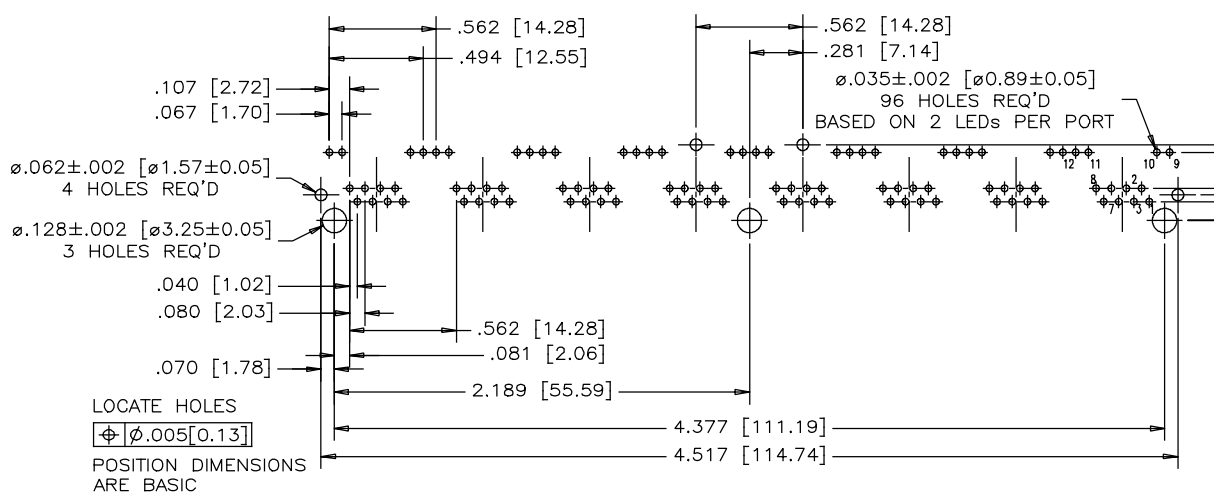
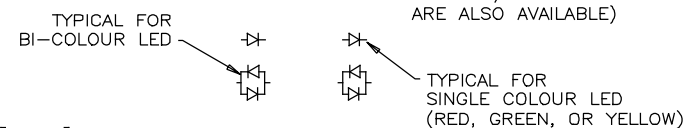

- MATERIALS:**
 PLASTIC HOUSING: HIGH TEMPERATURE THERMOPLASTIC
 FLAMMABILITY RATING UL 94V-0, COLOUR: BLACK

 CONTACTS: PHOSPHOR BRONZE
 PLATING: SELECTIVE GOLD PLATING ON MATING SURFACES,
 SEE AMPHENOL PART NUMBER FOR DETAIL.
 50 μ" [1.27 MICRONS] MIN. NICKEL UNDERPLATE
 100 μ" [2.54 MICRONS] MIN. MATTE TIN ON CONTACT TAILS

 SHIELD: STAINLESS STEEL WITH TIN DIPPED ON PCB TAILS.
- RECOMMENDED SOLDERING TEMPERATURE:**
 WAVE SOLDERING AT 260° C MAXIMUM FOR 5 SEC MAXIMUM.
- PART NUMBER:** RJE39-888-1XX0
 GOLD PLATING OPTION
 0=GOLD FLASH
 1=6u" GOLD PLATING
 2=15u" GOLD PLATING
 3=30u" GOLD PLATING
 4=50u" GOLD PLATING
 REFER TO LED OPTIONS DRAWING FOR ORDERING CODES

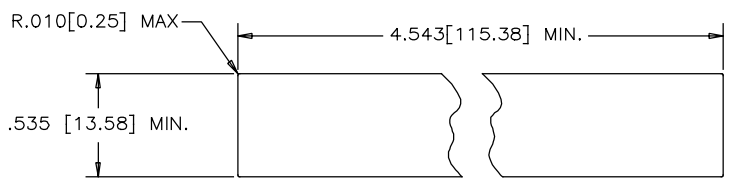

UNLESS SPECIFIED OTHERWISE	DRAWN	AMY.Z	DATE	SEP07/15	Amphenol Canada Corp. www.amphenolcanada.com
PRIMARY UNITS INCH	CHECKED	L.CHAN	DATE	SEP07/15	
SECONDARY MILLIMETER	M.E. APP'D				TITLE
REFERENCE IN PARENTHESES	Q.A. APP'D				8 PORT HIGH SPEED MODULAR JACK, 8 POSITIONS, 8 CONTACTS, SHIELDED, WITH LED'S OPTION - RoHS COMPLIANT
GENERAL TOLERANCES	DWG APPR.				DWG. NO.
1 DECIMAL PLACE ±0.025	ENG. REL. NO.				P-RJE39-888-1XX0
2 DECIMAL PLACES ±0.020	REF.				REV
3 DECIMAL PLACES ±0.015	THIRD ANGLE PROJECTION				A
ANGULAR DEGREES ±1.0°	DO NOT SCALE DRAWING				CODE ID NO. 03554 DWG SIZE: c SCALE: N/A SHEET 1 OF 1

THIS DOCUMENT CONTAINS PROPRIETARY INFORMATION AND SUCH INFORMATION MAY NOT BE DISCLOSED TO OTHERS FOR ANY PURPOSE OR USED FOR MANUFACTURING PURPOSES WITHOUT WRITTEN PERMISSION FROM AMPHENOL CANADA CORP.

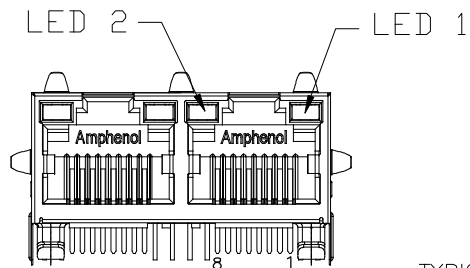

EXAMPLE:
PART NUMBER: RJE39-288-1XX0

LED COLOR CODE

TYPICAL FOR SINGLE



REVISIONS			
REV	DESCRIPTION, ECN, EAR NO.	DATE	APP'D
A	PROPOSAL	SEP07/15	L.CHAN
B	UPDATE PART NUMBER	MAR13/17	L.CHAN
C	ADD OPTION	MAR23/17	L.CHAN

LED SPECIFICATIONS:

FORWARD VOLTAGE: 2.1 VOLTS TYP.
REVERSE VOLTAGE: 5.0 VOLTS MIN.
LUMINOUS INTENSITY: 0.5 mCd MIN.
(AT If=2mA)

STORAGE TEMPERATURE: -40° TO 85° C
LEAD SOLDERING TEMPERATURE: 260° C
(5 SEC, 1/16" FROM CASE)
PLATING ON TAILS: TIN OR TIN/COPPER ALLOY OVER SILVER

PRIMARY COLOR FOR BI-COLOR
LEDS IN STANDARD ANODE/
CATHODE CONFIGURATION IS:
RED-GREEN= RED
RED-YELLOW= RED
GREEN-YELLOW= GREEN
GREEN-ORANGE= GREEN

CODE	LED 2 (LEFT)	LED 1 (RIGHT)	CODE	LED 2 (LEFT)	LED 1 (RIGHT)	CODE	LED 2 (LEFT)	LED 1 (RIGHT)
0	BLOCKED	BLOCKED	9	GREEN	BLOCKED	J	BiC RD/GR	YELLOW
1	YELLOW	GREEN	A	BiC GR/YE	BiC GR/YE	K	YELLOW	BiC GR/OR
2	BLOCKED	GREEN	B	BiC RD/GR	BiC RD/GR	L	BiC GR/YE	RED
3	YELLOW	BLOCKED	C	BiC RD/GR	BiC GR/YE	M	RED	YELLOW
4	GREEN	YELLOW	D	GREEN	BiC GR/YE	N	BiC GR/RD	BiC GR/YE
5	GREEN	GREEN	E	YELLOW	BiC GR/YE	P	GREEN	BiC RD/GR
6	YELLOW	YELLOW	F	BiC GR/YE	YELLOW	R	BiC GR/OR	GREEN
7	RED	GREEN	G	BiC GR/OR	BiC GR/OR	T	RED	RED
8	GREEN	RED	H	BiC GR/YE	GREEN	V	BiC RD/GR	GREEN
			W	ADDITIONAL	OPTIONS			

EXAMPLE OF ADDITIONAL LED OPTIONS:

PART NUMBER RJE39-288-1XW0-0X

ONLY USED FOR "W" OPTIONS USED IN FIRST LED CODE
ADDITIONAL LED COLOR CODE
DENOTES ADDITIONAL LED OPTIONS TO BE USED

CODE	LED 2 (LEFT)	LED 1 (RIGHT)	CODE	LED 2 (LEFT)	LED 1 (RIGHT)	CODE	LED 2 (LEFT)	LED 1 (RIGHT)
0	DO NOT USE		5	BLOCKED	YELLOW	E	GREEN	ORANGE
1	RED	BLOCKED	6	RED	BiC RD/GR	A	LOWC YE	LOWC YE
2	BiC GR/OR	YELLOW	7	BLOCKED	BiC RD/GR	B	LOWC YE	LOWC GR
3	YELLOW	RED	8	BiC RD/GR	BLOCKED	C	LOWC GR	LOWC YE
4	BLOCKED	RED	9	BiC GR/YE	BLOCKED	D	LOWC GR	LOWC GR
			M	RED	YELLOW			
			N	GREEN	BiC GR/OR			
			E	GREEN	ORANGE			
			F	ORANGE	GREEN			
			P	BiC RE/YE	GREEN			
			R	BiC RD/YE	BiC RD/YE			
			T	BiC GR/YE	BiC RE/GR			
			G	GREEN	BiC OR/GR			
			H	BLUE	RED			

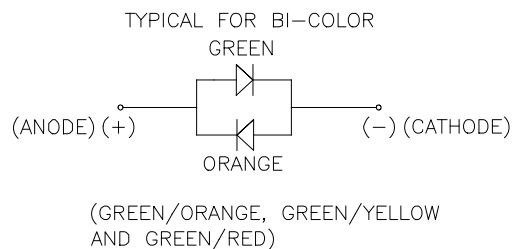

LEGEND

BiC=BI-COLOR LED
LOWC=LOW CURRENT LED
YE=YELLOW
GR=GREEN
RD=RED
OR=ORANGE

NOTE:

THE TWO DIGITS PRECEDING THE
ADDITIONAL LED CODE MUST BE
USED IN THE PART NUMBER, WHEN
ORDERING ANY OF THE ADDITIONAL
LED OPTIONS.



UNLESS SPECIFIED OTHERWISE	DRAWN Amy.Z	DATE SEP07/15	Amphenol Canada Corp. www.amphenolcanada.com
PRIMARY UNITS MILLIMETER	CHECKED Lawrence.C	SEP07/15	
SECONDARY INCH	M.E. APP'D		TITLE
REFERENCE IN PARENTHESES	Q.A. APP'D		LED OPTIONS FOR RJE39
GENERAL TOLERANCES	DWG APPR.		
1 DECIMAL PLACE ±0.45	ENG. REL. NO.		DWG. NO. P-RJE39-LEDs
2 DECIMAL PLACES ±0.30	REF.		REV C
3 DECIMAL PLACES ±0.15	THIRD ANGLE PROJECTION	DO NOT SCALE DRAWING	
ANGULAR DEGREES ±1.0°			CODE ID NO. 03554 DWG SIZE: c SCALE: N/A SHEET 1 OF 1



Компания «ЭлектроПласт» предлагает заключение долгосрочных отношений при поставках импортных электронных компонентов на взаимовыгодных условиях!

Наши преимущества:

- Оперативные поставки широкого спектра электронных компонентов отечественного и импортного производства напрямую от производителей и с крупнейших мировых складов;
- Поставка более 17-ти миллионов наименований электронных компонентов;
- Поставка сложных, дефицитных, либо снятых с производства позиций;
- Оперативные сроки поставки под заказ (от 5 рабочих дней);
- Экспресс доставка в любую точку России;
- Техническая поддержка проекта, помощь в подборе аналогов, поставка прототипов;
- Система менеджмента качества сертифицирована по Международному стандарту ISO 9001;
- Лицензия ФСБ на осуществление работ с использованием сведений, составляющих государственную тайну;
- Поставка специализированных компонентов (Xilinx, Altera, Analog Devices, Intersil, Interpoint, Microsemi, Aeroflex, Peregrine, Syfer, Eurofarad, Texas Instrument, Miteq, Cobham, E2V, MA-COM, Hittite, Mini-Circuits, General Dynamics и др.);

Помимо этого, одним из направлений компании «ЭлектроПласт» является направление «Источники питания». Мы предлагаем Вам помощь Конструкторского отдела:

- Подбор оптимального решения, техническое обоснование при выборе компонента;
- Подбор аналогов;
- Консультации по применению компонента;
- Поставка образцов и прототипов;
- Техническая поддержка проекта;
- Защита от снятия компонента с производства.



Как с нами связаться

Телефон: 8 (812) 309 58 32 (многоканальный)

Факс: 8 (812) 320-02-42

Электронная почта: org@eplast1.ru

Адрес: 198099, г. Санкт-Петербург, ул. Калинина, дом 2, корпус 4, литера А.