

## PET1300-12-054xA Series

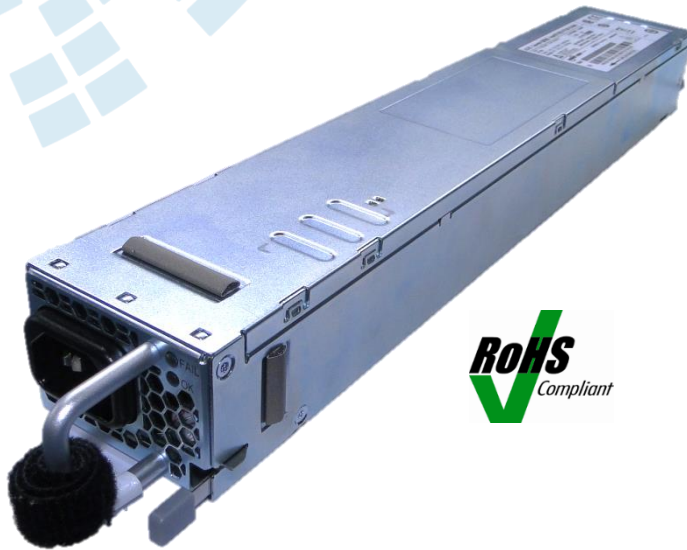

The **PET1300-12-054xA** is a 1300 Watt AC to DC power-factor-corrected (PFC) power supply that converts standard AC mains power into a main output of 12 VDC for powering intermediate bus architectures (IBA) in high performance and reliability servers, routers, and network switches. The PET1300-12-054xA meets international safety standards and displays the CE-Mark for the European Low Voltage Directive (LVD).

### Features

- High efficiency up to 94.0%
- Wide input voltage range: 90-264 VAC
- Active power factor correction
- Always-On 10 W standby output (3.3 V)
- Hot-plug capability
- Parallel operation with active current sharing
- Full digital control for circuit loop and power management
- High density design: 30.25 W/in<sup>3</sup>
- Compact form factor: 54.5 x 40.0 x 321.5 mm
- PMBus™ for control, programming and monitoring
- Fully protected (OTP, OCP, OVP, SCP)
- 4K Bytes of EEPROM for user information
- 2 Status LEDs: FAIL and OK with fault signaling
- Approved to the latest edition of following Safety Standards: UL/CSA60950-1, IEC / EN 60950-1
- Designed to meet Class A emissions per CISPR 22 and EN55022

### Applications

- High performance servers
- Routers
- Switches

**North America**  
+1-866.513.2839

**Asia-Pacific**  
+86.755.29885888

**Europe, Middle East**  
+353 61 225 977

# PET1300-12-054xA Series

## 1 Ordering Information

<b>PET</b>	<b>1300</b>	<b>-</b>	<b>12</b>	<b>-</b>	<b>054</b>	<b>X</b>	<b>A</b>
<b>Product Family</b> PET Front-Ends	<b>Power Level</b> 1300 W	<b>Dash</b>	<b>V1 Output</b> 12 V	<b>Dash</b>	<b>Width</b> 54 mm	<b>Airflow</b> N: Normal R: Reversed	<b>Input</b> A: AC

## 2 Overview

The PET1300-12-054xA AC/DC power supply is a fully DSP controlled, highly efficient front-end power supply. It incorporates resonance-soft-switching technology and interleaved power trains to reduce component stresses, providing increased system reliability and very high efficiency. With a wide input operational voltage range and minimal linear derating of output power with input voltage and temperature, the PET1300-12-054xA maximizes power availability in demanding server, network, and other high availability applications. The supply is fan cooled and ideally suited for integration with a matching airflow paths.

The PFC stage is an analogue solution; MCU is used to communicate with DSP chip on secondary side.

The DC/DC stage uses soft switching resonant techniques in conjunction with synchronous rectification. An active OR-ing device on the output ensures no reverse load current and hence it is ideally suited for operation in redundant power systems.

The always-on standby output with voltage level (3.3 Volts), provides power to external power distribution and management controllers. It is protected with an active OR-ing device for maximum reliability.

Status information is provided with front-panel LEDs. In addition, the power supply can be controlled and the fan speed set via the I<sup>2</sup>C bus. The I<sup>2</sup>C bus allows full monitoring of the supply, including input and output voltage, current, power, and inside temperatures.

Cooling is managed by a fan controlled by the DSP controller. The fan speed is adjusted automatically depending on the actual power demand and supply temperature and can be overridden through the I<sup>2</sup>C bus.

Figure 1 - PET1300-12-054xA Block Diagram

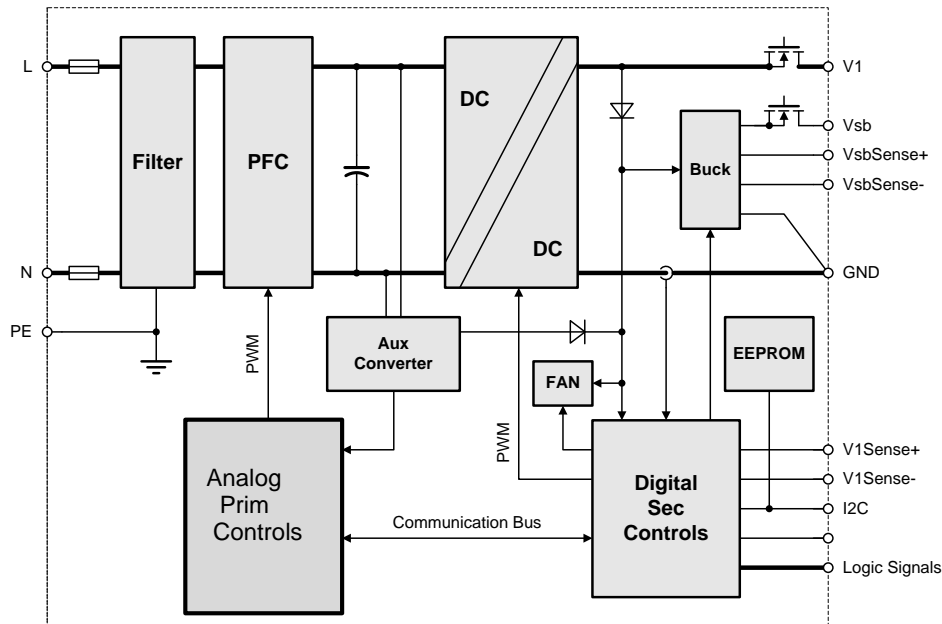

# PET1300-12-054xA Series

## 3 Input

General Condition:  $T_A = 0... +60\text{ }^\circ\text{C}$  unless otherwise noted.

PARAMETER	DESCRIPTION / CONDITION	MIN	NOM	MAX	UNIT
$V_{i\text{ nom}}$	Nominal Input Voltage	100		240	VAC
$V_i$	Input Voltage Ranges	Normal operating ( $V_{i\text{ min}}$ to $V_{i\text{ max}}$ )		264	VAC
$I_{i\text{ max}}$	Max Input Current	Vin=110 VAC/60Hz, Full load		13.6	$A_{\text{rms}}$
$I_{i\text{ p}}$	Inrush Current Limitation	$V_{i\text{ min}}$ to $V_{i\text{ max}}$ , TNTC = 25 °C		50	$A_p$
$F_i$	Input Frequency	47	50/60	63	Hz
PF	Power Factor	$V_{i\text{ nom}}$ , 50 Hz, > 0.2 $I_{i\text{ nom}}$		0.95	W/VA
$V_{i\text{ on}}$	Turn-on Input Voltage <sup>1)</sup>	Ramping up		90	VAC
$V_{i\text{ off}}$	Turn-off Input Voltage <sup>1)</sup>	Ramping down		83	VAC
Power	Rated Power (Figure 2&3) <sup>2)</sup>			1100	W
				1300	W
$\eta$	Efficiency without Fan	$V_{i\text{ in}} = 230\text{ V}, 12\text{ V} / 21.6\text{ A}, 3.3\text{ V} / 0.6\text{ A } T_A = 25\text{ }^\circ\text{C}$		93.0	
		$V_{i\text{ in}} = 230\text{ V}, 12\text{ V} / 54\text{ A}, 3.3\text{ V} / 1.5\text{ A } T_A = 25\text{ }^\circ\text{C}$		94.0	%
		$V_{i\text{ in}} = 230\text{ V}, 12\text{ V} / 108\text{ A}, 3.3\text{ V} / 3\text{ A } T_A = 25\text{ }^\circ\text{C}$		92.0	
$T_{\text{hold}}$	Hold-up Time	After last AC zero point, $V_1 > 11.6\text{ V}$ , $V_{\text{SB}}$ within regulation, $V_i = 230\text{ VAC}, 12\text{ V} / 108\text{ A}, 3.3\text{ V} / 3\text{ A}$		10	mS

<sup>1)</sup> The Front-End is provided with a minimum hysteresis of 3 V during turn-on and turn-off within the ranges.

<sup>2)</sup> The output power is should be derating as below curve if operation temperature increases from 45°C to 60°C.

Figure 2 - Derating on  $I_{\text{out}}$  vs  $V_{i\text{ in}}$  and  $T_a$  for PET1300-12-054NA

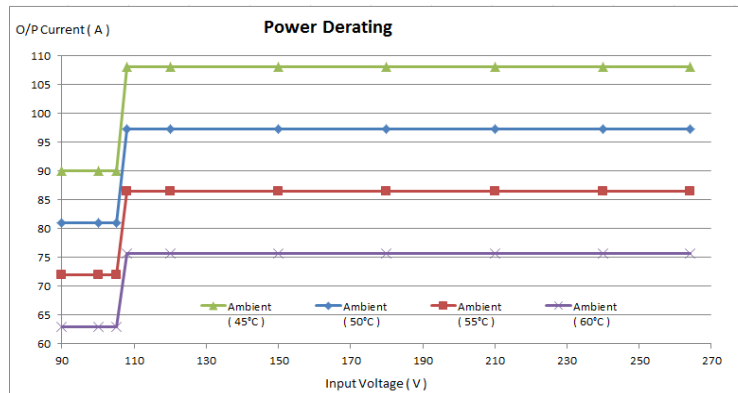
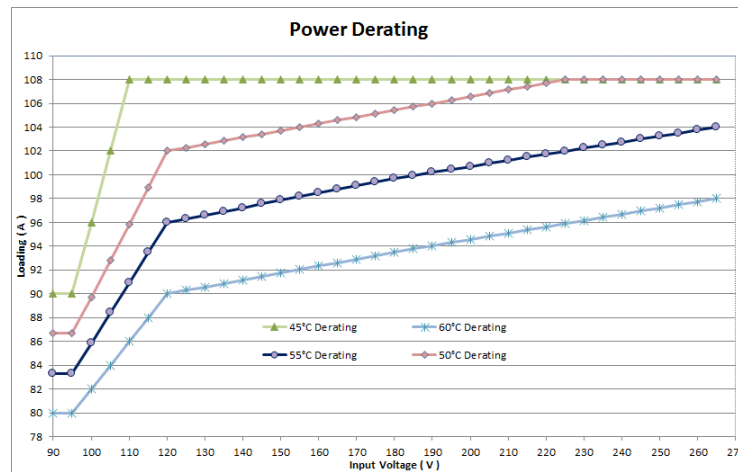

Figure 3 - Derating on  $I_{\text{out}}$  vs  $V_{i\text{ in}}$  and  $T_a$  for PET1300-12-054RA



866.513.2839

tech.support@psbel.com

belpowersolutions.com

# PET1300-12-054xA Series

Figure 4 - Efficiency Measurement Curve

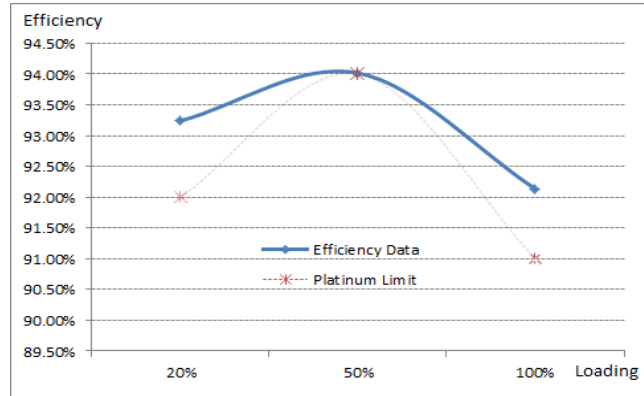

## 4 Output

General Condition:  $T_a = 0 \dots +60 \text{ }^\circ\text{C}$  unless otherwise noted.

PARAMETER	DESCRIPTION / CONDITION	MIN	NOM	MAX	UNIT
<b>Main Output V<sub>1</sub></b>					
V <sub>1 nom</sub>	Nominal Output Voltage		12.0		VDC
V <sub>1 set</sub>	Output Setpoint Accuracy	-0.5		+0.5	% V <sub>1 nom</sub>
dV <sub>1 tot</sub>	Total Regulation	-3		+3	% V <sub>1 nom</sub>
P <sub>1 nom</sub>	Nominal Output Power		1296		W
I <sub>1 nom</sub>	Nominal Output Current		108		A <sub>DC</sub>
V <sub>1 pp</sub>	Output Ripple Voltage			180	mVpp
dV <sub>1 Load</sub>	Load Regulation		60		mV
dV <sub>1 Line</sub>	Line Regulation		20		mV
dI <sub>share</sub>	Current Sharing ( <i>abs (I1-I2), between any two units in parallel</i> )			4.5	A
				5.6	A
dV <sub>dyn</sub>	Dynamic Load Regulation	-0.6		0.6	V
T <sub>rec</sub>	Recovery Time		0.5	1	mS
t <sub>AC V1</sub>	Start-up Time from AC			2	sec
t <sub>V1 rise</sub>	Rise Time		3		mS
C <sub>Load</sub>	Capacitive Loading			11000	μF
<b>Standby Output V<sub>SB</sub></b>					
V <sub>SB nom</sub>	Nominal Output Voltage		3.3		VDC
V <sub>SB set</sub>	Output Setpoint Accuracy	-1		+1	%V <sub>1nom</sub>
dV <sub>SB tot</sub>	Total Regulation	-1.5		+1.5	%V <sub>SBnom</sub>
P <sub>SB nom</sub>	Nominal Output Power		10		W
I <sub>SB nom</sub>	Nominal Output Current		3		A <sub>DC</sub>
V <sub>SB pp</sub>	Output Ripple Voltage			45	mVpp
dV <sub>SB</sub>	Droop		67		mV
dV <sub>SBdyn</sub>	Dynamic Load Regulation	-3		3	%V <sub>SBnom</sub>
T <sub>rec</sub>	Recovery Time			250	μs
t <sub>AC VSB</sub>	Start-up Time from AC			3	sec
t <sub>VSB rise</sub>	Rise Time		4	20	mS
C <sub>Load</sub>	Capacitive Loading			1000	μF

866.513.2839

tech.support@psbel.com

[belpowersolutions.com](http://belpowersolutions.com)

# PET1300-12-054xA Series

## 5 Protection

General Condition:  $T_a = 0 \dots +60^\circ\text{C}$  unless otherwise noted.

PARAMETER	DESCRIPTION / CONDITION	MIN	NOM	MAX	UNIT
F	Input Fuses (L+N)	Not user accessible, quick-acting (F)		16	A
$V_1$ ov	OV Threshold $V_1$	13.5		14.5	VDC
$t_{ov}$ v1	OV Latch Off Time $V_1$			1	mS
$V_{SB}$ ov	OV Threshold $V_{SB}$	3.6		4.3	VDC
$t_{ov}$ vSB	OV Latch Off Time $V_{SB}$			1	mS
$I_{V1}$ lim	Current Limit $V_1$ (Figure 5&6)	112	115	117	A <sub>DC</sub>
$I_{sb}$ lim	Current Limit $V_1$ $T_{amb} = 25^\circ\text{C}$	Standby output can recovery.		4.5	A
$I_{V1}$ sc	Max Short Circuit Current $V_1$		150		A
$t_{V1}$ sc	Short Circuit Regulation Time	$V_1 < 3\text{ V}$ , time until $I_{V1}$ is limited to $< I_{V1\text{ sc}}$		2	mS
$t_{V1}$ sc off	Short Circuit Latch Off Time	Time to latch off when in short circuit		500	mS
$T_{SD}$	Over Temperature On Heat Sinks	Automatic shut-down		115	$^\circ\text{C}$

**Note:** The OCP should be derating as below curve if operation temperature increases from  $45^\circ\text{C}$  to  $60^\circ\text{C}$ , And OCP warning is before 2 A than OCP set point.

Figure 5 -  $V_{in}$  vs Output Current for PET1300-12-054NA

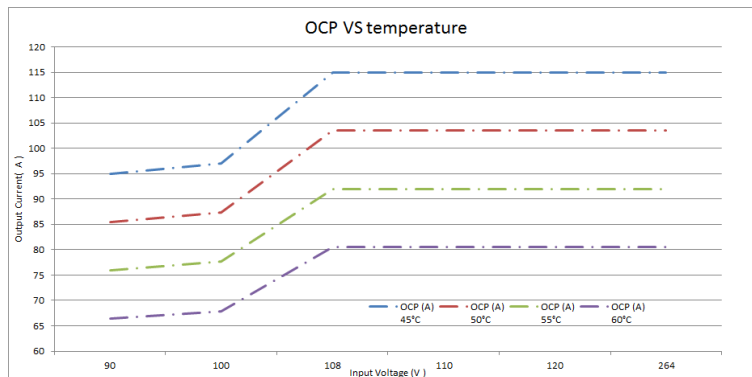
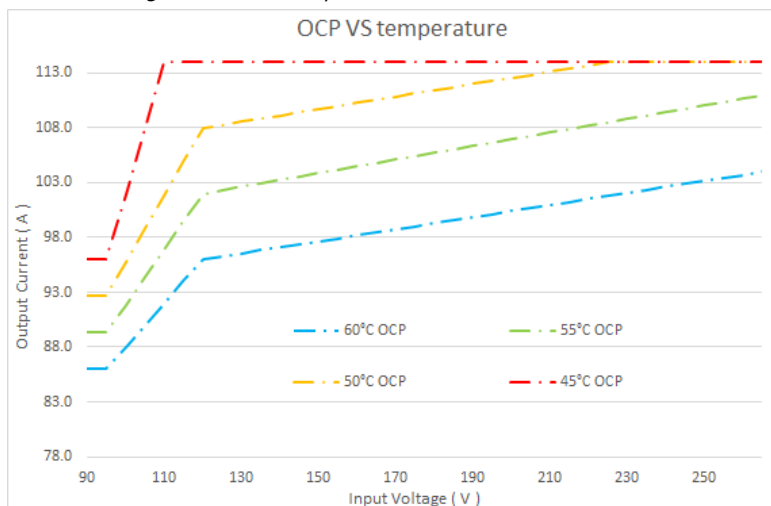

Figure 6 -  $V_{in}$  vs Output Current for PET1300-12-054RA



# PET1300-12-054xA Series

## 6 Signaling and Control

### 6.1 Front LEDs

The front-end has 2 front LEDs showing the status of the supply. LED number one is green which indicates presence of AC power, LED number two is bi-colored: green and yellow, which indicates DC power presence or fault. For the position and states of the LEDs see *Table 1*.

Table 1 - LED Status

POWER SUPPLY CONDITION	GREEN (OK) LED STATUS	AMBER (FAIL) LED STATUS
No AC power to all power supplies	OFF	OFF
Power Supply Failure (includes over voltage, over current, over temperature and fan failure)	OFF	ON
Power Supply Warning events where the power supply continues to operate (high temperature, high power and slow fan)	OFF	1 Hz Blinking
AC Present / 3.3 VSB on (PSU OFF)	1 Hz Blinking	OFF
Power Supply ON and OK	ON	OFF

\*When unit see fan failure, unit will shut down and can only be restarted by using PSON\_L signal or AC input power recycling or PMBus commands. Refer to software spec. for detail.

### 6.2 Electrical Characteristics

General Condition:  $T_a = 0 \dots +60 \text{ }^\circ\text{C}$  unless otherwise noted.

PARAMETER	DESCRIPTION/CONDITION	MIN	NOM	MAX	UNIT
<b>PSKILL_H/PSON_L/PRESENT_L</b>					
$V_{IL}$	Input Low Level Voltage	0		0.8	V
$V_{IH}$	Input High Level Voltage	2.0		3.6	V
$I_{IL, H}$	Maximum Input Sink or Source Current	0		1	mA
$R_{puPSKILL_H}$	Internal Pull Up Resistor on PSKILL_H		10		k $\Omega$
$R_{puPSON_L}$	Internal Pull Up Resistor on PSON_L		10		k $\Omega$
$R_{puPRESENT_L}$	Internal Pull Up Resistor on PRESENT_L		None		k $\Omega$
$R_{LOW}$	Resistance Pin to SGND for Low Level	0		1	k $\Omega$
$R_{HIGH}$	Resistance Pin to SGND for High Level	50			k $\Omega$
<b>PWOK_H Output</b>					
$V_{ext}$	Maximum External Pull Up Voltage			3.6	V
$V_{OL}$	Output Low Level Voltage	$I_{sink} < 2 \text{ mA}$	0	0.4	V
$V_{OH}$	Output High Level Voltage	$I_{source} < 0.5 \text{ mA}$	2.4	3.6	V
$R_{puPWOK_H}$	Internal Pull Up Resistor on PWOK_H		None		k $\Omega$
<b>ACOK_H Output</b>					
$V_{ext}$	Maximum External Pull Up Voltage			3.6	V
$V_{OL}$	Output Low Level Voltage	$I_{sink} < 2 \text{ mA}$	0	0.4	V
$V_{OH}$	Output High Level Voltage	$I_{source} < 0.5 \text{ mA}$	2.4	3.6	V
$R_{puACOK_H}$	Internal Pull Up Resistor on ACOK_H		None		k $\Omega$
<b>SMB_ALERT_L Output</b>					
$V_{ext}$	Maximum External Pull Up Voltage			12	V
$V_{OL}$	Output Low Level Voltage	$I_{sink} < 2 \text{ mA}$	0	0.4	V
$I_{OH}$	Maximum High Level Leakage Current			10	$\mu\text{A}$
$R_{puSMB\_ALERT\_L}$	Internal Pull Up Resistor on SMB_ALERT_L		None		k $\Omega$

866.513.2839

tech.support@psbel.com

[belpowersolutions.com](http://belpowersolutions.com)

# PET1300-12-054xA Series

## 6.3 Graphical User Interface

Bel Power Solutions provide with its “Bel Power Solutions I<sup>2</sup>C Utility” a Windows® XP/Vista/Win7 compatible graphical user interface allowing the programming and monitoring of the PET1300-12-054xA Front-End. The utility can be downloaded on [www.belpowersolutions.com](http://www.belpowersolutions.com) and supports both the PSMI and PMBus™ protocols.

The GUI allows automatic discovery of the units connected to the communication bus and will show them in the navigation tree. In the monitoring view the power supply can be controlled and monitored.

Figure 7 - I<sup>2</sup>C Bus to DSP and EEPROM

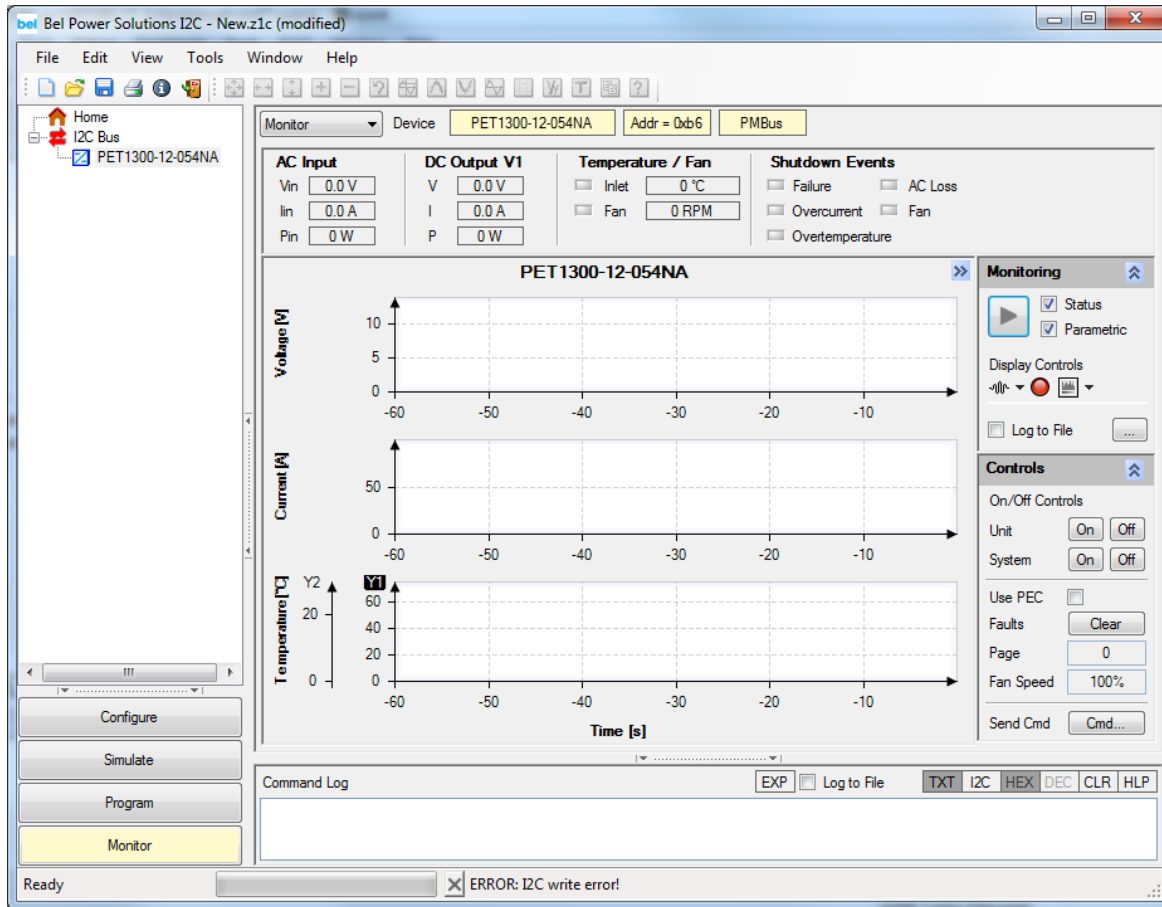

Table 2 - Accuracy for PMBus

COMMOND	10% ~ 20% FULL LOAD	20% ~ 100% FULL LOAD	REMARK
Read_lin	< 0.5 A	+/- 3%	It is for corresponding to max input current
Read_lout	+/- 2%	+/- 2%	It is for corresponding to max output current
Read_Vin	+/- 3%	+/- 2.5 V	
Read_Vout	+/- 2%	+/- 2%	
Read_Pin	---	+/- 15%	It is for corresponding to max input power
Read_Pout	+/- 3%	+/- 3%	It is for corresponding to max output power

## 6.4 PRESENT\_L

The PRESENT\_L is an output signal and it is used to sense the number of power supplies in the system (operational or not). This signal is connected to the power supply’s output ground. Electrical characteristics see 6.2.

866.513.2839

tech.support@psbel.com

[belpowersolutions.com](http://belpowersolutions.com)

# PET1300-12-054xA Series

Interconnect Diagram of PRESENT\_L Signal

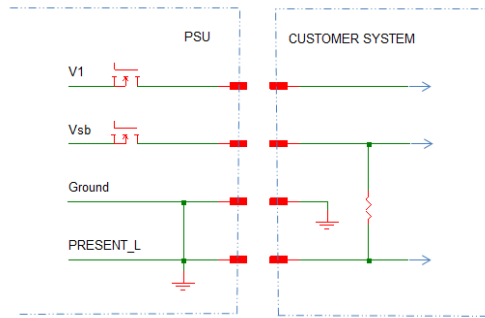

## 6.5 SMB\_ALERT\_L

The SMB\_ALERT\_L is an output signal and shall be an open collector with the pull-up resistor located at the receiving end and shall be capable of sinking up to 4 mA.

This signal indicates that the power supply is experiencing a problem that the user should investigate. This may be asserted due to Critical events or Warning events. See PMBUS specification for further details.

Interconnect Diagram of SMB\_ALERT\_L Signal

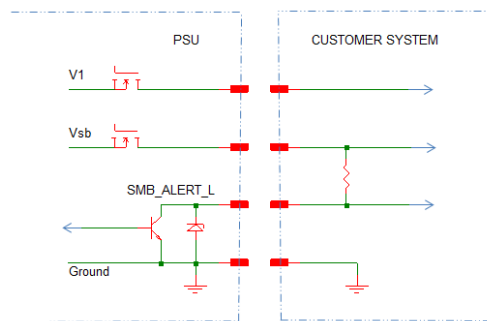

## 6.6 PSKILL\_H

This is an input signal and is used to force the 12 V main output off if the supply is removed from the system. At the system level this pin will be connected to the output return directly. When this input is low the power supply will operate. If the input is floating the 12 V main output will turn off while the 3.3 VSB will remain on. This signal overrides all other on-and-off signals. On the power supply connector, this pin is shorter than the others so it is a last-make and first-break contact. See below Table 3 for Logic Table.

Interconnect Diagram of PSKILL\_H Signal

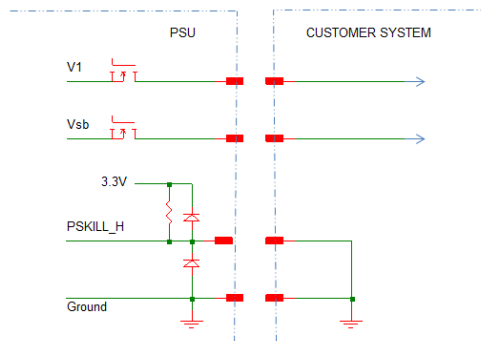

866.513.2839

tech.support@psbel.com

[belpowersolutions.com](http://belpowersolutions.com)



# PET1300-12-054xA Series

Table 3 - PS\_KILL Signal Characteristics

SIGNAL CHARACTERISTICS		
Signal Type:	Accepts a ground input from the system.	
Input Signal to the power supply	Pull-up to 3.3 VSB located in the power supply.	
PS_KILL = Low, PS_ON = Low	ON	
PS_KILL = Open, PS_ON = Low or Open	OFF	
PS_KILL = Low, PS_ON = Open	OFF	
	<b>MIN</b>	<b>MAX</b>
Source current, Vps_kill =Low		4 mA

## 6.7 PSON\_L

The PS\_ON\_L signal is an input signal used to remotely turn on/off the power supply. PS\_ON\_L is an active LOW signal that turns on the 12 V main output. In the low state this input will not source more than 4 mA of current. The 12 V output will be disabled when this input is driven HIGH, or open circuited. See Table 4 for Logic Table.

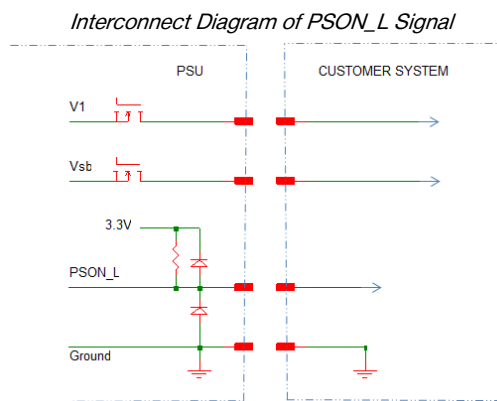

Table 4 - PS\_ON\_L Signal Characteristics

SIGNAL CHARACTERISTICS		
Signal Type:	Accepts an open collector/drain input from the system. Pull-up to 3.3 VSB located in power supply.	
Input signal to the power supply	Pull-up to 3.3 VSB located in power supply.	
PS_ON_L = Low, PS_KILL = Low	ON	
PS_ON_L = Open, PS_KILL = Low or Open	OFF	
PS_ON_L = Low, PS_KILL = Open	OFF	
	<b>MIN</b>	<b>MAX</b>
Output Source Current, VPS_ON_L= Low		4 mA

## 6.8 PW\_OK

PW\_OK is an output signal and will be pulled HIGH by the power supply to indicate that all the outputs are within the regulation limits of the power supply. When 12 V main output is < 10.9 V or > 13.2 V, or if any of the outputs fail due to over current protection, over voltage protection, over temperature, or fan failure then this output will be driven LOW. In the event when AC mains power is lost, this signal will be driven LOW at least 20 mS before the +3.3 VSB output is lost. The output will be an open collector/drain. The start of the PW\_OK delay time shall be inhibited as long as any power supply's 12 V output is in current limit. See Table 5.

# PET1300-12-054xA Series

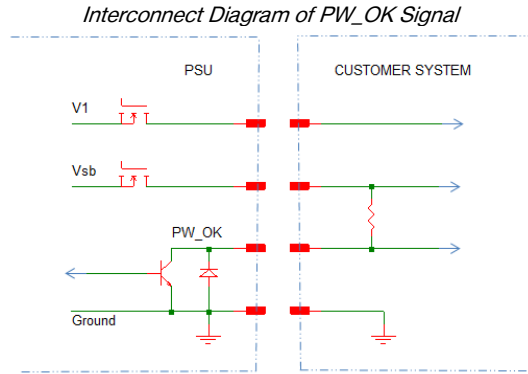
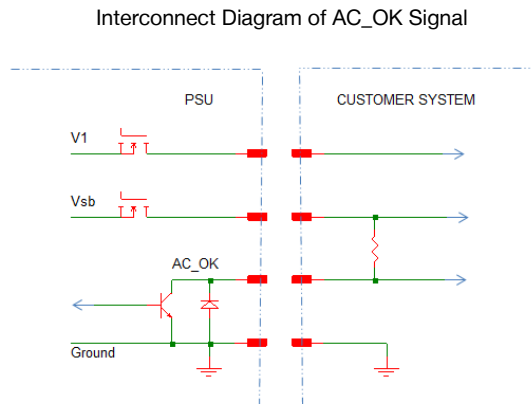

*Table 5 - PW\_OK Signal Characteristics*

SIGNAL CHARACTERISTICS		
Signal Type:	Open collector/drain (system side to provide pull-up, another pull-up to 3.3 VSB could also be located in the power supply)	
Output signal from the power supply		
PW_OK = High	Power OK	
PW_OK = Low	Power Not OK	
	<b>MIN</b>	<b>MAX</b>
Input Sink current, PW_OK = Low		4 mA
Output Source current, PW_OK = High		2 mA

## 6.9 AC\_OK

This signal is an output signal and will be asserted, driven HIGH, by the power supply to indicate that the input voltage meets the minimum requirements of Section 3.1.3. After falling outside the input voltage requirements for more than 20 mS, the signal must be driven LOW. The output will be an open collector/drain. See below Table 6.



*Table 6 - AC\_OK Signal Characteristics*

SIGNAL CHARACTERISTICS		
Signal Type:	Open collector/drain (system side to provide pull-up, another pull-up to 3.3 VSB could also be located in the power supply)	
Output signal from the power supply		
AC_OK = High	AC OK	
AC_OK = Low	AC Low (Not OK)	
	<b>MIN</b>	<b>MAX</b>
Input Sink current, AC_OK = Low		4 mA
Output Source current, AC_OK = High		2 mA

# PET1300-12-054xA Series

## 6.10 Current Sharing

All outputs shall be capable of operating in a redundant current share mode. A maximum of 6 power supplies may be operated in parallel. All outputs shall incorporate an isolation device (Or-ing MOSFET or diode) for fault isolation. Filter capacitors that are located after the isolation device shall be of high reliability and shall be de-rated sufficiently to minimize failures.

The 3.3 V output current sharing shall be of a droop type. The +12 V current sharing shall be a single wire type, active current sharing. Connecting the Ishare (current share) pins of each power supply together shall enable the current share feature. Shorting or opening of a current share pin shall not cause the output voltage to go out of steady state regulation.

For 12 V output the Ishare (load sharing) voltage shall be a linear function  $I_{share} [V] = 8 \times I_{out}/108$  (with 8 V at 108 A) for a single power supply (~74 mV/A).

At light load, the load share becomes difficult because of low feedback signal. Refer to Table 2 for current sharing accuracy.

The current balance accuracy is calculated as:  $2 \times |I_1 - I_2| / (I_1 + I_2)$ , where the  $I_1$  is the PSU1 load current and  $I_2$  is the PSU2 load current.

## 6.11 Remote Sense

The outputs specified shall incorporate remote sense and will compensate for specified load cable drop. In the event of loss of remote sense, all outputs shall revert to internal sense so as to limit the outputs to less than 105% of nominal.

## 7 Timing Diagram and Table

Unless defined otherwise, all control signals shall be TTL compatible with respect to the output return and shall be isolated from the primary circuit and be SELV rated. All input signals shall be driven from an open collector with the pull-up resistor located in the power supply and shall be capable of sourcing up to 4 mA. General LVTTTL signal levels are specified in below table except where explicitly specified otherwise.

Table 7 - Low-Voltage TTL (LVTTTL) Voltage Levels

PARAMETER	SYMBOL	MIN	MAX	UNITS
Output High Voltage	Voh	2.4	3.6	V
Output Low Voltage	Vol	0	0.4	V
Input High Voltage	Vih	2.0	3.6	V
Input Low Voltage	Vil	0	0.8	V

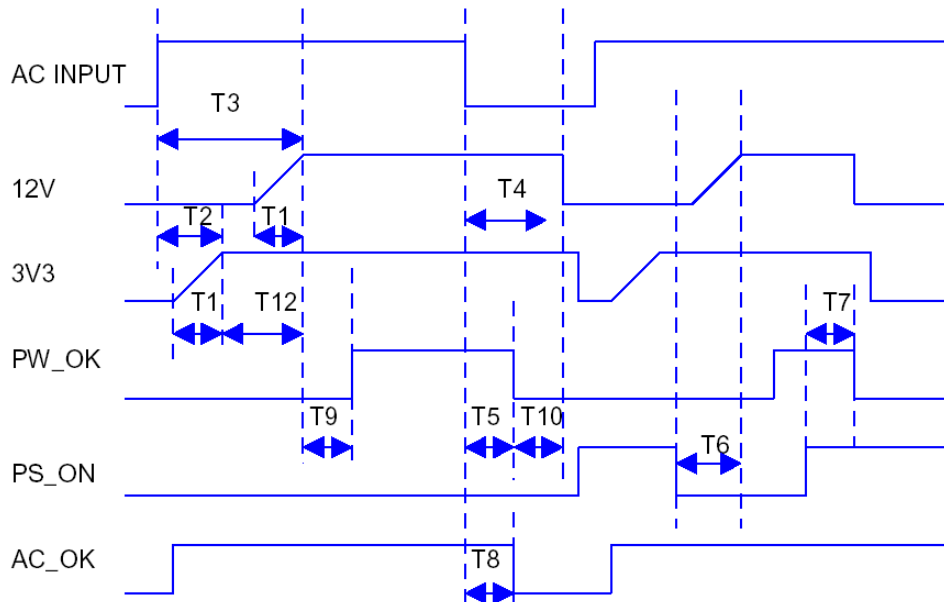

866.513.2839

tech.support@psbel.com

[belpowersolutions.com](http://belpowersolutions.com)

# PET1300-12-054xA Series

PARAMETER	MIN.	TYP.	MAX.	UNITS	CONDITION/COMMENTS
T1 (T <sub>out_rise</sub> )	0.5		100	mS	Output voltage rise time from each main output
T2 (T <sub>sb_on_delay</sub> )			2500	mS	Delay from AC being applied to 3V3 being within regulation
T3 (T <sub>ac_on_delay</sub> )			3000	mS	Delay from AC being applied to all output voltages being within regulation
T4 (T <sub>vout_holdup</sub> )	10			mS	Time all output voltages, including 3V3, stay within regulation after loss of AC
T5 (T <sub>pw_ok_holdup</sub> )	5			mS	Delay from loss of AC to de-assertion of PW_OK
T6 (T <sub>ps_on_delay</sub> )	5		400	mS	Delay from PS_ON_L active to output voltages within regulation limits
T7 (T <sub>ps_on_pw_ok</sub> )			50	mS	Delay from PS_ON_L de-active to PW_OK being de-asserted
T8 (T <sub>ac_ok_off</sub> )			20	mS	Delay from loss of AC input to de-assertion of AC_OK
T9 (T <sub>pw_ok_on</sub> )	100		1000	mS	Delay from output voltages within regulation limits to PW_OK asserted at turn on
T10 (T <sub>pw_ok_off_12V</sub> )	1		700	mS	Delay from PW_OK de-asserted to 12 VDC dropping out of regulation limits
T11 (T <sub>pw_ok_off_3V3</sub> )	20			mS	Delay from PW_OK de-asserted to 3V3 dropping out of regulation limits
T12 (T <sub>sb_vout</sub> )	50		1000	mS	Delay from 3V3 being in regulation to 12 VDC being in regulation at AC turn on.
T13 (T <sub>ac_ok_on</sub> )			1500	mS	Delay from AC being applied to assertion of AC_OK

## 8 Immunity

**NOTE:** Most of the immunity requirements are derived from EN 55024: 1998/A2:2003.

PARAMETER	DESCRIPTION / CONDITION	CRITERION
ESD Contact Discharge	IEC / EN 61000-4-2, ±8 kV, 25+25 discharges per test point (metallic case, LEDs, connector body)	A
ESD Air Discharge	IEC / EN 61000-4-2, ±15 kV, 25+25 discharges per test point (non-metallic user accessible surfaces)	A
Radiated Electromagnetic Field	IEC / EN 61000-4-3, 10 V/m, 1 kHz/80% Amplitude Modulation, 1 µs Pulse Modulation, 10 kHz...2 GHz	A
Burst	IEC / EN 61000-4-4, level 3 AC port ±2 kV, 1 minute DC port ±1 kV, 1 minute	A
Surge	IEC / EN 61000-4-5 4 kV CM 2 kV DM	A
RF Conducted Immunity	IEC/EN 61000-4-6, Level 3, 10 Vrms, CW, 0.1 ... 80 MHz	A
Voltage Dips and Interruptions	IEC/EN 61000-4-11 1: V <sub>i</sub> 230 V, 100% Load, Phase 0°, Dip 100%, Duration 10 mS 2: V <sub>i</sub> 230 V, 100% Load, Phase 0°, Dip 100%, Duration 20 mS 3: V <sub>i</sub> 230 V, 100% Load, Phase 0°, Dip 100%, Duration > 20 mS	A V <sub>SB</sub> : A, V <sub>1</sub> : B V <sub>SB</sub> , V <sub>1</sub> : B

### 8.1 Emission

PARAMETER	DESCRIPTION / CONDITION	CRITERION
Conducted Emission	EN55022 / CISPR 22: 0.15 ... 30 MHz, QP and AVG, single unit	Class A
	EN55022 / CISPR 22: 0.15 ... 30 MHz, QP and AVG, 2 units in rack system	Class A
Radiated Emission	EN55022 / CISPR 22: 30 MHz ... 1 GHz, QP, single unit	Class A
	EN55022 / CISPR 22: 30 MHz ... 1 GHz, QP, 2 units in rack system	Class A
Harmonic Emissions	IEC61000-3-2, V <sub>in</sub> = 115 VAC / 60 Hz, & V <sub>in</sub> = 230 VAC / 50 Hz, 100% Load	Class A
Acoustical Noise	46 dBA at 1 meter, 25 °C, 50% Load	-
AC Flicker	IEC61000-3-3, V <sub>in</sub> = 230 VAC / 60 Hz, 100% Load	Pass

866.513.2839

tech.support@psbel.com

[belpowersolutions.com](http://belpowersolutions.com)

# PET1300-12-054xA Series

## 9 Safety / Approvals

Maximum electric strength testing is performed according to UL / CSA 60950-1, IEC/EN 60950-1. Input-to-output electric strength tests should not be repeated in the field. Bel Power Solutions will not honor any warranty claims resulting from electric strength field tests.

PARAMETER	DESCRIPTION / CONDITION	MIN	NOM	MAX	UNIT
Agency Approvals	Approved to the latest edition of the following standards: UL / CSA 60950-1 IEC / EN 60950-1			Approved by independent body (see CE Declaration)	
Isolation Strength	Input (L/N) to case (PE)			Basic	
	Input (L/N) to output			Reinforced	
Electrical Strength Test	Output to case (PE)			Functional	
	Input to case	2121			VDC
	Input to output	4242			

## 10 Environmental

PARAMETER	DESCRIPTION / CONDITION	MIN	NOM	MAX	UNIT
T <sub>A</sub>	Ambient Temperature	$V_{i \min}$ to $V_{i \max}$ , $I_{1 \text{ norm}}$ , $I_{SB \text{ nom}}$	0	+60	°C
T <sub>S</sub>	Storage Temperature	Non-operational	-40	+85	°C
	Altitude	Operational, above Sea Level	-	10,000	Feet
N <sub>a</sub>	Audible Noise	$V_i = 230 \text{ VAC}$ , 50% $I_{o \text{ nom}}$ , $T_A = 25^\circ\text{C}$	46		dBA

Note: Refer to Figure 2&3 for Derating.

## 11 Mechanical

PARAMETER	DESCRIPTION / CONDITION	MIN	NOM	MAX	UNIT
Dimensions	Width	54.1	54.5	54.9	
	Height	39.6	40.0	40.4	mm
	Depth	321.1	321.6	322.1	
M	Weight		1.09		kg

Otherwise stated, Tolerance: 0.5mm – 120mm: ±0.3mm; 120mm – 400mm: ±0.5mm.

Figure 8 - Side View 1

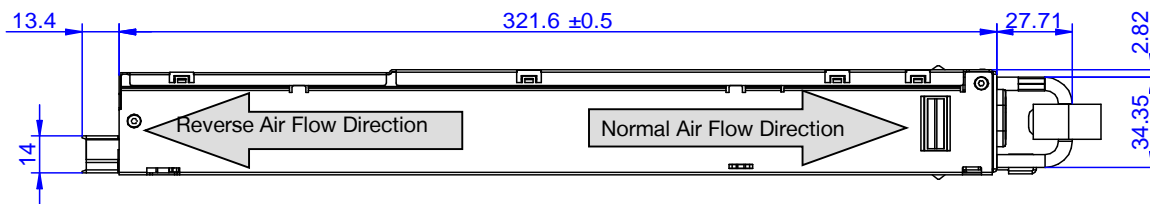

**NOTE:** A 3D step file of the power supply casing is available on request.

# PET1300-12-054xA Series

Figure 9 - Top View

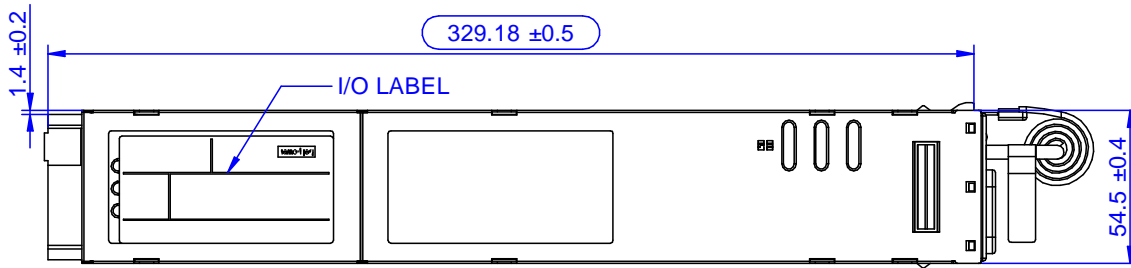

Figure 10 - Side View 2

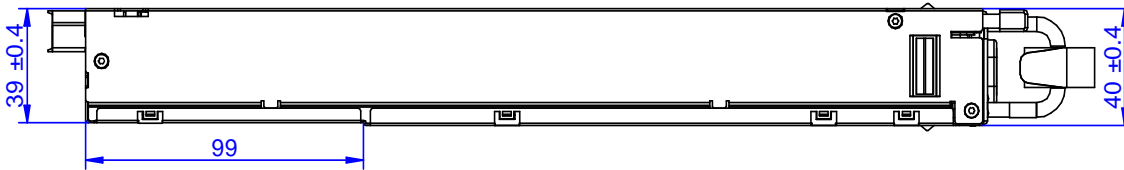
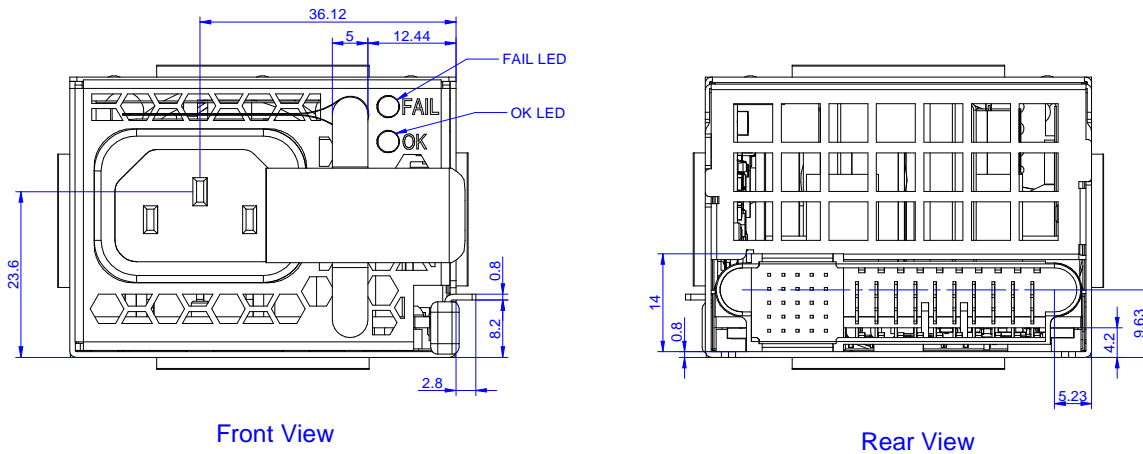
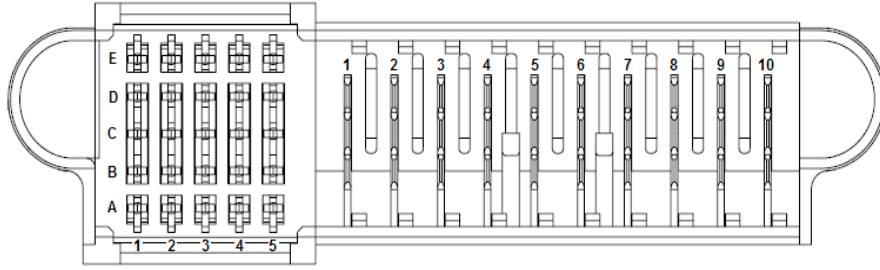

Figure 11 - Front and Rear View



# PET1300-12-054xA Series

## 12 Connections



Unit: Tyco Electronics P/N 1926736-2 or FCI 10122460-002LF

Counter part: Tyco Electronics P/N 2-1926739-5 or FCI 10108888-R10253SLF (Bel Power Solutions P/N: ZES.00672)

PIN	NAME	DESCRIPTION
<b>Output</b>		
6, 7, 8, 9, 10	V1	+12 VDC main output
1, 2, 3, 4, 5	PGND	Power ground (return)
<b>Control Pins</b>		
A1, B1, C1, D1, E1	VSB	Standby positive output (+3.3 V)
A2, B2	SGND	Signal ground (return)
C2	NC	Reserved
D2	NC	Reserved
E2	NC	Reserved
A3	PS_KILL	Power supply kill (lagging pin)
B3	NC	Reserved
C3	SDA	I <sup>2</sup> C data signal line
D3	V1_SENSE_R	Main output negative sense
E3	V1_SENSE	Main output positive sense
A4	SCL	I <sup>2</sup> C clock signal line
B4	PS_ON_L	Power supply on input (connect to A2/B2 to turn unit on)
C4	ALERT_L	SMB Alert signal output
D4	ISHARE	12 V current share signal (LS)
E4	AC_OK	AC input OK signal
A5	A0	Address 0
B5	NC	Reserved
C5	PW_OK	Power OK signal output (lagging pin)
D5	A1	Address 1
E5	PRESENT_L	Power supply present (lagging pin)

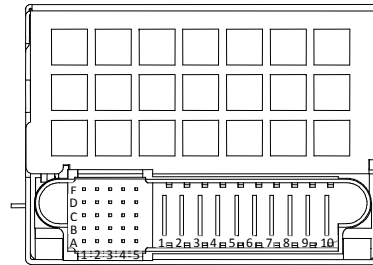

# PET1300-12-054xA Series

## 13 Accessories

ITEM	DESCRIPTION	ORDERING PART NUMBER	SOURCE
	<b>Bel Power Solutions I<sup>2</sup>C Utility</b> Windows XP/Vista/7 compatible GUI to program, control and monitor PET Front-Ends (and other I <sup>2</sup> C units)	N/A	<a href="http://www.belpowersolutions.com">www.belpowersolutions.com</a>
Evaluation board	<b>Dual Connector Board</b> Connector board to operate 2 PET units in parallel. Includes an on-board USB to I <sup>2</sup> C converter (use <i>Bel Power Solutions I<sup>2</sup>C Utility</i> as desktop software).	VRA.00333.0	Bel Power Solutions

## 14 PMBus Communication

### 14.1 Address Select

Table 8 - Address Select

A2	A1	A0	UNIT ADDRESS	EEPROM ADDRESS
0	0	0	0xB0	0xA0
0	0	1	0xB2	0xA2
0	1	0	0xB4	0xA4
0	1	1	0xB6	0xA6

Note: A2 = 1 is not implemented.

### 14.2 PMBus Commands

**NOTE:**

Reference: PMBus Power System Management Protocol Specification Part II – Command Language Revision 1.1.

Commands not included in the table below are Not Implemented.

Feature that are To Be Defined (TBD), or Not Implemented are shaded.

R = Read-Only; RW = Read/Write; W = Write-Only.

Table 9 - PMBus Commands

COMMAND NAME	BIT NAME	CODE	BIT	VALUE	ACCESS	DATA BYTES	REMARKS
PAGE		00h		-	RW	1	Page 0 applies to + 12 V output Page 1 applies to + 3.3 V output Other Page values are considered invalid and will generate an INVALID_DATA error.
OPERATION		01h				1	
			7-6	-	RW		0b00 = OFF 0b10 = ON (Default)
			5-0	0d	R		Not Implemented
CLEAR_FAULTS		03h		-	W	0	Clear all bits in all status registers.
CAPABILITY		19h			R	1	
	PACKET_ERROR_CHECKING		7	0b1			Supported
	MAXIMUM_BUS_SPEED		6-5	0b01			400 kHz
	SMBALERT#		4	0b1			Supported
	RESERVED		3-0	0b0000			Reserved
VOUT_MODE		20h		-	R	1	

866.513.2839

tech.support@psbel.com

[belpowersolutions.com](http://belpowersolutions.com)



# PET1300-12-054xA Series

MODE		7-5	0b000			Linear
PARAMETER		4-0	0b10111			N = -9
FAN_CONFIG_1_2	3Ah			R	1	
		7	0b1			Fan1 Installed
		6	0b0			Fan1 Commanded in Duty Cycle
		5-4	0b01			Fan1 (2) Tachometer Pulses per Revolution
		3	0b0			Fan2 Not Installed
		2	0b0			Don't Care
		1-0	0b00			Don't Care
FAN_COMMAND_1	3Bh		-	RW	2	MIN = 0 → 0% MAX = 100 → 100% Values outside limits will generate INVALID_DATA error. Write request is executed only if the desired Fan speed is greater than what is required by the PSU. Fan Speed = FAN_COMMAND*21000RPM/100
STATUS_BYTE	78h			R	1	STATUS bits remain set, even if the fault or warning is removed. They are reset by: CLEAR_FAULTS Command AC Recycle PSON Recycle
BUSY		7	0b0			Not Implemented
OFF		6	-			
VOUT_OV		5	-			
IOUT_OC		4	-			
VIN_UV		3	-			
TEMPERATURE		2	-			
CML		1	-			
NONE_OF_THE_ABOVE		0	0b0			Not Implemented
STATUS_WORD	79h			R	2	
VOUT		F	-			
IOUT/POUT		E	-			
INPUT		D	-			
MFR		C	-			
POWER_GOOD#		B	-			
FANS		A	-			
OTHER		9	-			
UNKNOWN		8	0b0			Not Implemented
STATUS_BYTE		7-0	-			See STATUS_BYTE
STATUS_VOUT	7Ah			R	1	
VOUT_OV_FAULT		7	-			Asserts when an OV fault condition is detected on V1 output. SMB Alert Mask = 1 (Default)
VOUT_OV_WARNING		6	0b0			Not Implemented
VOUT_UV_WARNING		5	0b0			Not Implemented
VOUT_UV_FAULT		4	-			Asserts when an UV fault condition is detected on V1 output. SMB Alert Mask = 1 (Default)

866.513.2839

tech.support@psbel.com

[belpowersolutions.com](http://belpowersolutions.com)

# PET1300-12-054xA Series

VOUT_MAX_WARNING		3	0b0			Not Implemented
TON_MAX_FAULT		2	-			Asserts when V1 output is not in regulation 3s after PSON and AC is applied. SMB Alert Mask = 1 (Default)
TOFF_MAX_WARNING		1	0b0			Not Implemented
PWR_ON_TRACKING_ERROR		0	0b0			Not Implemented
STATUS_IOUT	7Bh			R	1	
IOUT_OC_FAULT		7	-			Asserts when an OC fault condition is detected on V1 output. SMB Alert Mask = 1 (Default)
IOUT_OC_FAULT_LV		6	0b0			Not Implemented
IOUT_OC_WARNING		5	0b0			Asserts when an OC warning condition is detected on V1 output. SMB Alert Mask = 0 (Default)
IOUT_UC_FAULT		4	0b0			Not Implemented
ISHARE_FAULT		3	0b0			Not Implemented
PIN_LIMITING_MODE		2	0b0			Not Implemented
POUT_OP_FAULT		1	0b0			Not Implemented
POUT_OP_WARNING		0	0b0			Not Implemented
STATUS_INPUT	7Ch			R	1	
VIN_OV_FAULT		7	0b0			Not Implemented
VIN_OV_WARNING		6	0b0			Not Implemented
VIN_UV_WARNING		5	0b0			Not Implemented
VIN_UV_FAULT		4	0b0			Not Implemented
UNIT_OFF_VIN_LOW		3	-			Asserts when the PSU is disabled because of low input voltage. SMB Alert Mask = 1 (Default)
IIN_OC_FAULT		2	0b0			Not Implemented
IIN_OC_WARNING		1	0b0			Not Implemented
PIN_OP_WARNING		0	0b0			Not Implemented
STATUS_TEMPERATURE	7Dh			R	1	
OT_FAULT		7	-			Asserts when an OT fault condition is detected. SMB Alert Mask = 1 (Default)
OT_WARNING		6	-			Asserts when an OT warning condition is detected. SMB Alert Mask = 1 (Default)
UT_WARNING		5	0b0			Not Implemented
UT_FAULT		4	0b0			Not Implemented
RESERVED		3-0	0b0000			Reserved
STATUS_CML	7Eh			R	1	
INVALID_COMMAND		7	-			Asserts when the System tries to access unsupported commands, write to supported commands with read-only access, or read supported commands with write-only access. SMB Alert Mask = 0 (Default)
INVALID_DATA		6	-			Asserts when the System tries to write invalid data (including when PEC byte is incorrect) to supported commands with write access. SMB Alert Mask = 0 (Default)

866.513.2839

tech.support@psbel.com

[belpowersolutions.com](http://belpowersolutions.com)

# PET1300-12-054xA Series

PEC_FAIL		5	-			Asserts when the received PEC byte is incorrect. SMB Alert Mask = 0 (Default)
MEMORY_FAULT		4	0b0			Not Implemented
PROCESSOR_FAULT		3	0b0			Not Implemented
RESERVED		2	0b0			Reserved
OTHER_COMM_FAULT		1	0b0			Asserts when the communication between monitoring components inside the PSU is lost. SMB Alert Mask = 0 (Default)
OTHER_MEMORY_FAULT		0	0b0			Not Implemented
STATUS_OTHER	7Fh			R	1	
RESERVED		7	0b0			Reserved
RESERVED		6	0b0			Reserved
INPUT A FUSE		5	0b0			Not Implemented
INPUT B FUSE		4	0b0			Not Implemented
INPUT A ORING		3	0b0			Not Implemented
INPUT B ORING		2	0b0			Not Implemented
OUTPUT ORING		1	-			Asserts when a fault is detected on the V1 ORing device. SMB Alert Mask = 0 (Default)
RESERVED		0	0b0			Reserved
STATUS_MFR_SPECIFIC	80h			R	1	
RESERVED		7	0b0			Reserved
RESERVED		6	0b0			Reserved
RESERVED		5	0b0			Reserved
RESERVED		4	0b0			Reserved
VSB_UV_FAULT		3	-			Asserts when an UV fault condition is detected on Vsb output. SMB_Alert Mask = 0 (Default)
VSB_OV_FAULT		2	-			Asserts when an OV fault condition is detected on Vsb output. SMB_Alert Mask = 0 (Default)
PHASE_SHARE_FAULT		1	-			Asserts when there is a current imbalance between DCDC Phases. SMB_Alert Mask = 0 (Default)
HOLDUP_FAULT		0	-			Asserts when V1 goes out of regulation if Bulk voltage level is reduced. SMB_Alert Mask = 0 (Default)
STATUS_FANS_1_2	81h			R	1	
FAN1_FAULT		7	-			Asserts when a Fan fault condition is detected. SMB Alert Mask = 1 (Default)
FAN2_FAULT		6	0b0			Not Implemented
FAN1_WARNING		5	0b0			Not Implemented
FAN2_WARNING		4	0b0			Not Implemented
FAN1_SPEED_OVERRIDE		3	-			Asserts when the Fan is running according to the speed defined by the System. SMB Alert Mask = 0 (Default)
FAN2_SPEED_OVERRIDE		2	0b0			Not Implemented
AIR_FLOW_FAULT		1	0b0			Not Implemented

866.513.2839

tech.support@psbel.com

[belpowersolutions.com](http://belpowersolutions.com)

# PET1300-12-054xA Series

AIR_FLOW_WARNING		0	0b0			Not Implemented
READ_VIN	88h		-	R	2	Linear Format, N = -1
READ_IIN	89h		-	R	2	Linear Format, N = -6
READ_VOUT	8Bh		-	R	2	Linear Format, N = -9 Refer to Section 8.3.1 of PMBus Spec Part II Revision 1.1
READ_IOUT	8Ch		-	R	2	Linear Format, N = -3
READ_TEMPERATURE_1	8Dh		-	R	2	Linear Format, N = -2 Inlet Temperature
READ_TEMPERATURE_2	8Eh		-	R	2	Linear Format, N = -2 Outlet Temperature
READ_TEMPERATURE_3	8Fh		-	R	2	Linear Format, N = -2 ORing FET Temperature
READ_FAN_SPEED_1	90h		-	R	2	Linear Format, N = 5
READ_POUT	96h		-	R	2	Linear Format, N = 1
READ_PIN	97h		-	R	2	Linear Format, N = 1
MFR_ID	99h		-	R	CNT+9	ID = Bel Power Format: ASCII
MFR_MODEL	9Ah		-	R	CNT+16	MODEL = PET1300-12-054xA Format: ASCII
MFR_REVISION	9Bh		-	R	CNT+3	REVISION = vv Format: ASCII
MFR_LOCATION	9Ch		-	R	2	LOCATION = xx Format: ASCII
MFR_DATE	9Dh		-	R	CNT+4	DATE = yyww Format: ASCII
MFR_SERIAL	9Eh		-	R	CNT+18	SERIAL = xxxzzzzzzzzvvvvuuuu Format: ASCII
CALIBRATION_POINTER	C0h		-	RW	2	<b>For Bel Power Solutions Use Only</b>
CALIBRATION_DATA	C1h		-	RW	2	<b>For Bel Power Solutions Use Only</b>
CALIBRATION_COMMAND	C2h		-		2	<b>For Bel Power Solutions Use Only</b>
RESERVED		F-1	0d	R		Reserved
COMMIT_TO_FLASH		0	-	RW		0 = No Action 1 = Commit RAM to Flash
READ_VSTBY	C3h		-	R	2	<b>For Bel Power Solutions Use Only</b> Same format as READ_VOUT
READ_ISTBY	C4h		-	R	2	<b>For Bel Power Solutions Use Only</b> Same format as READ_IOUT
READ_VOUT_INT	C5h		-	R	2	<b>For Bel Power Solutions Use Only</b> Same format as READ_VOUT
BOOTLOADER_STATUS_REQUEST	C7h			RW	2	<b>For Bel Power Solutions Use Only</b>
BOOTLOADER_PAGE_DATA	C8h		-	W	-	<b>For Bel Power Solutions Use Only</b>
PRODUCT_ID_NUMBER	C9h			R	2	<b>For Bel Power Solutions Use Only</b> Refer to Table 3
FW_REV	CAh			R	2	<b>For Bel Power Solutions Use Only</b>
SEC_DSP_MAJOR		F-C	-			M = 0 to 9
SEC_DSP_MINOR		B-8	-			m = 0 to 9 i.e: Mm = 25 → Revision 2.5
PRI_DSP_MAJOR		7-4	-			M = 0 to 9
PRI_DSP_MINOR		3-0	-			m = 0 to 9 i.e: Mm = 13 → Revision1.3
SEC_CTRL1	CCh			R		<b>For Bel Power Solutions Use Only</b>
SEC_CTRL2	CDh			R		<b>For Bel Power Solutions Use Only</b>
SEC_STAT	CEh			R		<b>For Bel Power Solutions Use Only</b>
PRI_STAT	CFh			R		<b>For Bel Power Solutions Use Only</b>

866.513.2839

tech.support@psbel.com

[belpowersolutions.com](http://belpowersolutions.com)

# PET1300-12-054xA Series

MFR_SPECIFIC_00 (PSU_CONTROL)	D0h				2	
RESERVED		F-1	0d	R		Reserved
EEPROM_WP		0	-	RW		EEP Write-Protect (WP) Control 0 = Enable WP (Default) 1 = Disable WP
MFR_SPECIFIC_05 (FW_VERSION)	D5h		-	R	8	Format: xx.xx.xx (e.g. 01.02.01). The length is fixed at 8 Ascii characters. Each field will be an Ascii value stored in one byte. * For example: aa.bb.cc, where aa is development stage (P0, P1 ... A0); bb is primary mcu firmware revision (00 ~ 99); cc is secondary mcu firmware revision (00 ~ 99). <b>NO BYTE COUNT</b>
MFR_SPECIFIC_09 (SMB_ALERT_MASKING)	D9h		-	RW	7	Refer to Table 4 <b>NO BYTE COUNT</b>

Table 10 - Product ID Number

BIT(S)	DESCRIPTION	REMARKS
F-A	Product Family	TBD
9-8	Communication Protocol	0b00 = Reserved 0b01 = Reserved 0b10 = PMBus 0b11 = Reserved
7-0	Product Part Number	TBD

Table 11 - SMB\_ALERT Masking

BYTE	BYTE DESCRIPTION	BIT	BIT DESCRIPTION	DEFAULT
0	GLOBAL_MASK	7	Not Implemented	-
		6	Not Implemented	-
		5	Not Implemented	-
		4	Not Implemented	-
		3	Not Implemented	-
		2	Not Implemented	-
		1	Not Implemented	-
		0	Global Mask. Clear to disable SMB_ALERT	1
1	STATUS_VOUT	7	VOUT_OV_FAULT Mask	1
		6	Not Implemented	-
		5	Not Implemented	-
		4	VOUT_UV_FAULT Mask	1
		3	Not Implemented	-
		2	TON_MAX_FAULT Mask	1
		1	Not Implemented	-
		0	Not Implemented	-
2	STATUS_IOUT	7	IOUT_OC_FAULT Mask	1
		6	Not Implemented	-
		5	Not Implemented	-
		4	Not Implemented	-

866.513.2839

tech.support@psbel.com

[belpowersolutions.com](http://belpowersolutions.com)

# PET1300-12-054xA Series

		3	Not Implemented	-
		2	Not Implemented	-
		1	Not Implemented	-
		0	Not Implemented	-
3	STATUS_TEMPERATURE	7	OT_FAULT Mask	1
		6	OT_WARNING Mask	1
		5	Not Implemented	-
		4	Not Implemented	-
		3	Not Implemented	-
		2	Not Implemented	-
		1	Not Implemented	-
		0	Not Implemented	-
4	STATUS_INPUT	7	Not Implemented	-
		6	Not Implemented	-
		5	Not Implemented	-
		4	Not Implemented	-
		3	UNIT_OFF_VIN_LOW Mask	1
		2	Not Implemented	-
		1	Not Implemented	-
		0	Not Implemented	-
5	STATUS_FANS_1_2	7	FAN1_FAULT Mask	1
		6	Not Implemented	-
		5	Not Implemented	-
		4	Not Implemented	-
		3	FAN1_SPEED_OVERRIDE Mask	0
		2	Not Implemented	-
		1	Not Implemented	-
		0	Not Implemented	-
6	STATUS_CML	7	INVALID_COMMAND Mask	0
		6	INVALID_DATA Mask	0
		5	PEC_FAIL Mask	0
		4	Not Implemented	-
		3	Not Implemented	-
		2	Not Implemented	-
		1	Not Implemented	-
		0	Not Implemented	-

For more information on these products consult: [tech.support@psbel.com](mailto:tech.support@psbel.com)

**NUCLEAR AND MEDICAL APPLICATIONS** - Products are not designed or intended for use as critical components in life support systems, equipment used in hazardous environments, or nuclear control systems.

**TECHNICAL REVISIONS** - The appearance of products, including safety agency certifications pictured on labels, may change depending on the date manufactured. Specifications are subject to change without notice.

866.513.2839

[tech.support@psbel.com](mailto:tech.support@psbel.com)

[belpowersolutions.com](http://belpowersolutions.com)





Компания «ЭлектроПласт» предлагает заключение долгосрочных отношений при поставках импортных электронных компонентов на взаимовыгодных условиях!

Наши преимущества:

- Оперативные поставки широкого спектра электронных компонентов отечественного и импортного производства напрямую от производителей и с крупнейших мировых складов;
- Поставка более 17-ти миллионов наименований электронных компонентов;
- Поставка сложных, дефицитных, либо снятых с производства позиций;
- Оперативные сроки поставки под заказ (от 5 рабочих дней);
- Экспресс доставка в любую точку России;
- Техническая поддержка проекта, помощь в подборе аналогов, поставка прототипов;
- Система менеджмента качества сертифицирована по Международному стандарту ISO 9001;
- Лицензия ФСБ на осуществление работ с использованием сведений, составляющих государственную тайну;
- Поставка специализированных компонентов (Xilinx, Altera, Analog Devices, Intersil, Interpoint, Microsemi, Aeroflex, Peregrine, Syfer, Eurofarad, Texas Instrument, Miteq, Cobham, E2V, MA-COM, Hittite, Mini-Circuits, General Dynamics и др.);

Помимо этого, одним из направлений компании «ЭлектроПласт» является направление «Источники питания». Мы предлагаем Вам помощь Конструкторского отдела:

- Подбор оптимального решения, техническое обоснование при выборе компонента;
- Подбор аналогов;
- Консультации по применению компонента;
- Поставка образцов и прототипов;
- Техническая поддержка проекта;
- Защита от снятия компонента с производства.



#### Как с нами связаться

**Телефон:** 8 (812) 309 58 32 (многоканальный)

**Факс:** 8 (812) 320-02-42

**Электронная почта:** [org@eplast1.ru](mailto:org@eplast1.ru)

**Адрес:** 198099, г. Санкт-Петербург, ул. Калинина, дом 2, корпус 4, литера А.