

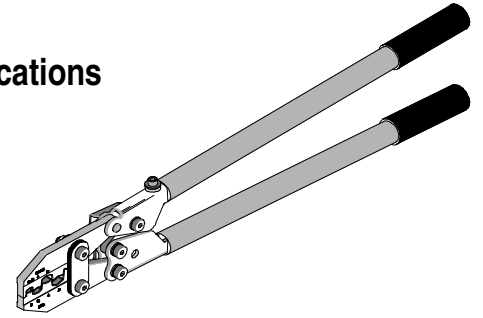

**Hand Crimp Tool**  
**Operating Instruction Sheet and Specifications**  
**Order No. 64001-3900**  
**Engineering No. MCT-8200**  
**(Replaces 19284-0035)**



**FEATURES**

- Heavy-duty cable crimping tool with hand held precision
- Tool can be used with insulated and non-insulated terminals in wire sizes 2 to 8 AWG
- A ratchet feature is standard
- Perfect for maintenance and lower volume crimping
- Long handles provide maximum mechanical advantage which reduces operator fatigue

**SCOPE**

Perma-Seal™, InsulKrimp®, NylaKrimp®, VersaKrimp™ Terminals and Splices 2–8 AWG. Fully insulated and non-insulated Ring Tongue terminals also Step Down Butt and Parallel Splices.

**Testing**

**Mechanical**

The tensile test, or pull test is, a means of evaluating the mechanical properties of the crimped connections. The following charts show the UL and Government specifications (MIL-T-7928) for various wire sizes. The tensile strength is shown in pounds. It indicates the minimum acceptable force to break or separate the terminal from the conductor.

Wire Size (AWG)	*UL - 486 A	*UL - 486 C	**Military
8	90	45	225
6	100	50	300
4	140	N/A	400
2	180	N/A	550

\*UL - 486 A - Terminals (Copper conductors only)

\*UL - 486 C - Butt Splices, Parallel Splices

\*\*Military – Military Approved Terminals only as listed

The following is a partial list of the product part numbers and their specifications that this tool is designed to run. We will be adding to this list and an up to date copy is available on [www.molex.com](http://www.molex.com)

Wire Size: 8 8.50mm <sup>2</sup>					
Terminal No.	Terminal Eng No. (REF)	Wire Strip Length		Insulation Diameter Maximum	
		In	mm	In	mm
19067-0003	D-950-08	.375	9.53	.350	8.89
19067-0006	D-950-10	.375	9.53	.350	8.89
19067-0008	D-950-14	.375	9.53	.350	8.89
19067-0012	D-950-56	.375	9.53	.350	8.89
19067-0016	D-951-10	.375	9.53	.350	8.89
19067-0018	D-951-14	.375	9.53	.350	8.89
19067-0022	D-951-38	.375	9.53	.350	8.89

Wire Size: 8 8.50mm <sup>2</sup>					
Terminal No.	Terminal Eng No. (REF)	Wire Strip Length		Insulation Diameter Maximum	
		In	mm	In	mm
19067-0025	D-951-56	.375	9.53	.350	8.89
19067-0028	D-952-12	.375	9.53	.350	8.89
19067-0030	D-952-38	.375	9.53	.350	8.89
19067-0031	D-952-76	.375	9.53	.350	8.89
19067-0032	D-953-12	.375	9.53	.350	8.89
19067-0033	D-953-34	.375	9.53	.350	8.89
19067-0034	D-953-58	.375	9.53	.350	8.89

Wire Size: 8 8.50mm <sup>2</sup>					
Terminal No.	Terminal Eng No. (REF)	Wire Strip Length		Insulation Diameter Maximum	
		In	mm	In	mm
19067-0037	D-956-08	.375	9.53	.350	8.89
19067-0039	D-956-10	.375	9.53	.350	8.89
19067-0041	D-956-14	.375	9.53	.350	8.89
19067-0128	D-951-76	.375	9.53	.350	8.89
19067-0129	D-952-58	.375	9.53	.350	8.89
19071-0134	D-650-08X	.315	8.00	.385	9.78
19071-0136	D-650-10X	.315	8.00	.385	9.78
19071-0140	D-650-14X	.315	8.00	.385	9.78
19071-0144	D-650-56X	.315	8.00	.385	9.78
19071-0146	D-651-10X	.315	8.00	.385	9.78
19071-0148	D-651-14X	.315	8.00	.385	9.78
19071-0153	D-651-56X	.315	8.00	.385	9.78
19071-0162	D-652-38X	.315	8.00	.385	9.78
19071-0164	D-652-58X	.315	8.00	.385	9.78
19071-0166	D-652-76X	.315	8.00	.385	9.78
19071-0173	D-653-58X	.315	8.00	.385	9.78
19071-0176	D-656-06X	.315	8.00	.385	9.78
19071-0178	D-656-08X	.315	8.00	.385	9.78
19071-0180	D-656-10X	.315	8.00	.385	9.78
19071-0182	D-656-14X	.315	8.00	.385	9.78
19071-0334	D-652-12X	.315	8.00	.385	9.78
19154-0041	D-654X	.432	10.97	.385	9.78
19154-0044	DC-654X	.420	10.66	.380	9.65
19154-0047	ED-662X	.500	12.70	.435	11.05
19164-0079	SD-8	.387	9.83	.370	9.40
19164-0080	SD-656-10	.300	7.60	.375	9.54
19164-0081	SD-651-14	.300	7.60	.375	9.54
19164-0082	SD-652-38	.300	7.60	.375	9.54
19164-0083	SD-651-56	.300	7.60	.375	9.54
19164-0457	SD-652-12	.300	7.60	.375	9.54
19164-0458	SD-253-58	.300	7.60	.375	9.54
19164-0459	SD-253-34	.300	7.60	.375	9.54
19164-0833	SDC-354	.300	7.60	.375	9.54
19193-0146	D-350-08X	.315	8.00	N/A	N/A
19193-0149	D-350-10	.315	8.00	N/A	N/A
19193-0157	D-350-56	.315	8.00	N/A	N/A
19193-0159	D-351-10	.320	8.13	N/A	N/A
19193-0163	D-351-14	.320	8.13	N/A	N/A
19193-0184	D-352-38	.330	8.38	N/A	N/A
19193-0186	D-352-56	.330	8.38	N/A	N/A
19193-0187	D-352-76	.330	8.38	N/A	N/A
19193-0192	D-353-34	.330	8.38	N/A	N/A
19193-0195	D-353-58	.330	8.38	N/A	N/A
19193-0198	D-356-06	.358	9.08	N/A	N/A
19193-0204	D-356-14	.358	9.08	N/A	N/A
19205-0004	D-355	.408	10.36	N/A	N/A
19215-0034	D-354	.387	9.83	N/A	N/A
19215-0037	DC-354	.400	10.16	N/A	N/A
19215-0042	ED-362	.500	12.70	N/A	N/A

Wire Size: 6 16.0mm <sup>2</sup>					
Terminal No.	Terminal Eng No. (REF)	Wire Strip Length		Insulation Diameter Maximum.	
		In	mm	In	mm
19063-0050	E-757-10	.368	9.35	.345	8.76
19063-0052	E-757-14	.368	9.35	.345	8.76
19063-0062	E-758-12	.368	9.35	.345	8.76
19063-0066	E-758-58	.368	9.35	.345	8.76
19063-0069	E-760-08	.368	9.35	.345	8.76
19067-0045	E-957-10	.469	11.91	.428	10.87
19067-0047	E-957-14	.469	11.91	.428	10.87
19067-0052	E-957-38	.469	11.91	.428	10.87
19067-0055	E-957-56	.469	11.91	.428	10.87
19067-0059	E-957-76	.469	11.91	.428	10.87
19067-0061	E-958-12	.469	11.91	.428	10.87
19067-0063	E-958-38	.469	11.91	.428	10.87
19067-0065	E-958-76	.469	11.91	.428	10.87
19067-0067	E-960-08	.469	11.91	.428	10.87
19067-0069	E-960-10	.469	11.91	.428	10.87
19067-0071	E-960-14	.469	11.91	.428	10.87
19067-0073	E-960-56	.469	11.91	.428	10.87
19071-0188	E-657-10X	.469	11.91	.440	11.18
19071-0190	E-657-14X	.469	11.91	.440	11.18
19071-0193	E-657-38X	.469	11.91	.440	11.18
19071-0196	E-657-56X	.469	11.91	.440	11.18
19071-0201	E-658-12X	.469	11.91	.440	11.18
19071-0208	E-658-76X	.469	11.91	.440	11.18
19071-0218	E-660-08X	.469	11.91	.440	11.18
19071-0221	E-660-10X	.469	11.91	.440	11.18
19071-0225	E-660-14X	.469	11.91	.440	11.18
19071-0229	E-660-56X	.469	11.91	.440	11.18
19154-0047	ED-662X	.500	12.7	.435	11.05
19193-0209	E-357-10	.395	9.65	N/A	N/A
19193-0212	E-357-14	.395	9.65	N/A	N/A
19193-0229	E-358-14	.375	9.52	N/A	N/A
19193-0230	E-358-38	.375	9.52	N/A	N/A
19193-0233	E-358-58	.375	9.52	N/A	N/A
19193-0234	E-358-76	.375	9.52	N/A	N/A
19193-0238	E-359-34	.375	9.52	N/A	N/A
19193-0243	E-360-08	.392	9.96	N/A	N/A
19193-0251	E-360-56	.392	9.96	N/A	N/A
19202-0055	E-762	.493	12.51	.345	8.76
19205-0006	E-361	.477	12.12	N/A	N/A
19215-0040	E-362	.500	12.70	N/A	N/A
19215-0042	ED-362	.500	12.70	N/A	N/A

Wire Size: 4 25.0mm <sup>2</sup>					
Terminal No.	Terminal Eng No. (REF)	Wire Strip Length		Insulation Diameter Maximum	
		In	mm	In	mm
19063-0078	F-766-10	.432	10.97	.432	10.97
19063-0079	F-766-12	.432	10.97	.432	10.97
19063-0080	F-766-14	.432	10.97	.432	10.97

Wire Size: 4 25.0mm <sup>2</sup>					
Terminal No.	Terminal Eng No. (REF)	Wire Strip Length		Insulation Diameter Maximum	
		In	mm	In	mm
19063-0086	F-767-56	.438	11.11	.432	10.97
19063-0089	F-770-34	.432	10.97	.432	10.97
19067-0076	F-966-12	.501	12.73	.510	12.95
19067-0077	F-966-14	.501	12.73	.510	12.95
19067-0078	F-966-38	.501	12.73	.510	12.95
19067-0079	F-966-56	.501	12.73	.510	12.95
19067-0080	F-966-76	.501	12.73	.510	12.95
19067-0081	F-967-10	.501	12.73	.510	12.95
19067-0082	F-967-14	.501	12.73	.510	12.95
19067-0084	F-967-56	.501	12.73	.510	12.95
19067-0085	F-969-12	.501	12.73	.510	12.95
19067-0087	F-969-58	.501	12.73	.510	12.95
19067-0088	F-970-34	.501	12.73	.510	12.95
19071-0231	F-666-10X	.425	10.80	.515	13.08
19071-0234	F-666-12X	.425	10.80	.515	13.08
19071-0237	F-666-14X	.425	10.80	.515	13.08
19071-0240	F-666-38X	.425	10.80	.515	13.08
19071-0243	F-666-56X	.425	10.80	.515	13.08
19071-0250	F-667-10X	.425	10.80	.515	13.08
19071-0253	F-667-14X	.425	10.80	.515	13.08
19154-0048	F-664X	.745	19.15	.605	15.37
19193-0254	F-366-10	.447	11.35	N/A	N/A
19193-0258	F-366-12	.447	11.35	N/A	N/A
19193-0261	F-366-14	.447	11.35	N/A	N/A
19193-0278	F-367-56	.447	11.35	N/A	N/A
19193-0283	F-369-38	.447	11.35	N/A	N/A
19193-0285	F-369-58	.447	11.35	N/A	N/A
19193-0289	F-370-34	.447	11.35	N/A	N/A
19193-0293	F-370-58	.447	11.35	N/A	N/A
19202-0056	F-764	.547	13.89	.432	10.97
19205-0007	F-365	.547	13.89	N/A	N/A
19215-0045	F-364	.547	13.89	N/A	N/A

Wire Size: 2 35.0mm <sup>2</sup>					
Terminal No.	Terminal Eng No. (REF)	Wire Strip Length		Insulation Diameter Maximum	
		In	mm	In	mm
19063-0094	G-774-14	.495	12.57	.512	13.00
19063-0097	G-774-58	.495	12.57	.512	13.00
19067-0090	G-974-12	.559	14.20	.600	15.24
19067-0092	G-974-38	.559	14.20	.600	15.24
19067-0093	G-974-56	.559	14.20	.600	15.24
19067-0094	G-974-76	.559	14.20	.600	15.24
19067-0095	G-975-10	.559	14.20	.600	15.24
19067-0096	G-975-14	.559	14.20	.600	15.24
19067-0097	G-975-38	.559	14.20	.600	15.24
19067-0098	G-975-56	.559	14.20	.600	15.24
19067-0099	G-977-34	.559	14.20	.600	15.24
19067-0100	G-977-58	.559	14.20	.600	15.24

Wire Size: 2 35.0mm <sup>2</sup>					
Terminal No.	Terminal Eng No. (REF)	Wire Strip Length		Insulation Diameter Maximum	
		In	mm	In	mm
19071-0272	G-674-12X	.490	12.45	.650	16.51
19071-0273	G-674-14X	.490	12.45	.650	16.51
19071-0277	G-674-58X	.490	12.45	.650	16.51
19071-0279	G-675-10X	.490	12.45	.650	16.51
19071-0281	G-675-14X	.490	12.45	.650	16.51
19071-0283	G-675-38X	.490	12.45	.650	16.51
19071-0285	G-675-56X	.490	12.45	.650	16.51
19154-0049	G-672X	.640	16.25	.650	16.51
19193-0297	G-374-14	.505	12.83	N/A	N/A
19193-0298	G-374-38	.505	12.83	N/A	N/A
19193-0299	G-374-56	.505	12.83	N/A	N/A
19193-0320	G-377-34	.490	12.45	N/A	N/A
19205-0008	G-373	.680	17.27	N/A	N/A
19215-0046	G-372	.610	15.49	N/A	N/A

MILITARY Wire Size: 8 8.50mm <sup>2</sup>					
Terminal No.	Terminal Eng No. (REF)	Wire Strip Length		Insulation Diameter Maximum	
		In	mm	In	mm
19193-0152	D-350-14	.315	8.00	N/A	N/A
19193-0167	D-351-38	.320	8.13	N/A	N/A
19193-0171	D-351-56	.320	8.13	N/A	N/A
19193-0179	D-352-12	.330	8.38	N/A	N/A
19193-0200	D-356-08	.358	9.08	N/A	N/A
19193-0202	D-356-10	.358	9.08	N/A	N/A

MILITARY Wire Size: 6 16.0mm <sup>2</sup>					
Terminal No.	Terminal Eng No. (REF)	Wire Strip Length		Insulation Diameter Maximum	
		In	mm	In	mm
19063-0054	E-757-38	.368	9.35	.345	8.76
19063-0056	E-757-56	.368	9.35	.345	8.76
19063-0071	E-760-10	.368	9.35	.345	8.76
19063-0073	E-760-14	.368	9.35	.345	8.76
19193-0216	E-357-38	.395	9.65	N/A	N/A
19193-0219	E-357-56	.395	9.65	N/A	N/A
19193-0226	E-358-12	.375	9.52	N/A	N/A
19193-0245	E-360-10	.392	9.96	N/A	N/A
19193-0248	E-360-14	.392	9.96	N/A	N/A

MILITARY Wire Size: 4 25.0mm <sup>2</sup>					
Terminal No.	Terminal Eng No. (REF)	Wire Strip Length		Insulation Diameter Maximum	
		In	mm	In	mm

MILITARY					
Wire Size: 4 25.0mm <sup>2</sup>					
Terminal No.	Terminal Eng No. (REF)	Wire Strip Length		Insulation Diameter Maximum	
		In	mm	In	mm
19063-0081	F-766-38	.447	11.35	.432	10.97
19063-0082	F-766-56	.447	11.35	.432	10.97
19063-0085	F-767-14	.438	11.13	.432	10.97
19193-0264	F-366-38	.470	11.94	N/A	N/A
19193-0267	F-366-56	.470	11.94	N/A	N/A
19193-0273	F-367-10	.470	11.94	N/A	N/A
19193-0275	F-367-14	.470	11.94	N/A	N/A
19193-0281	F-369-12	.470	11.94	N/A	N/A

MILITARY					
Wire Size: 2 35.0mm <sup>2</sup>					
Terminal No.	Terminal Eng No. (REF)	Wire Strip Length		Insulation Diameter Maximum	
		In	mm	In	mm
19063-0093	G-774-12	.495	12.57	.512	13.00
19063-0100	G-775-14	.495	12.57	.512	13.00
19063-0101	G-775-38	.495	12.57	.512	13.00
19193-0302	G-374-76	.505	12.83	N/A	N/A
19193-0303	G-375-10	.505	12.83	N/A	N/A
19193-0305	G-375-14	.505	12.83	N/A	N/A
19193-0307	G-375-38	.505	12.83	N/A	N/A
19193-0309	G-375-56	.505	12.83	N/A	N/A

### OPERATION

Open the tool by first closing the jaws sufficiently for the ratchet mechanism to release.

#### Crimping Terminals

1. Insert the terminal in the proper nest (for insulated or bare terminals) as marked on the tool with the barrel up and centered in the nest.
2. Partially close the tool to hold the terminal securely in place. See Figure 1.
3. Insert the properly stripped wire into the terminal barrel. See Figure 2. Cycle the tool.

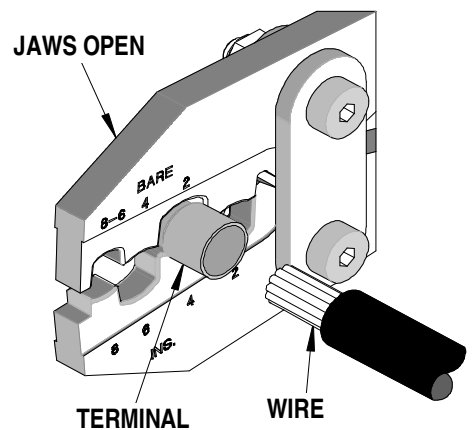

Figure 1

**Note:** The tamper-proof ratchet action will not release the tool until it has been fully closed.

4. Remove the crimp and inspect for proper crimp location. Molex offers a Crimp Inspection Handbook for closed barrel industrial product. See our website or contact your sales engineer.

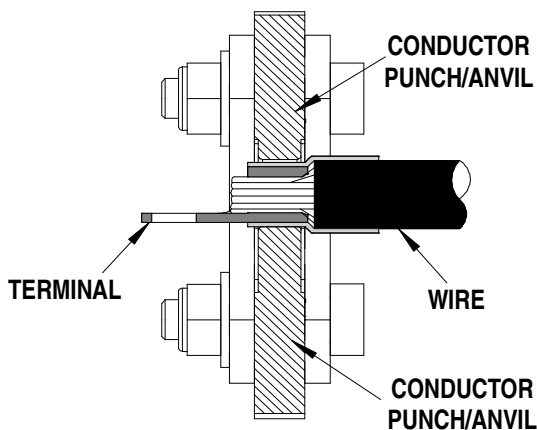

Figure 2

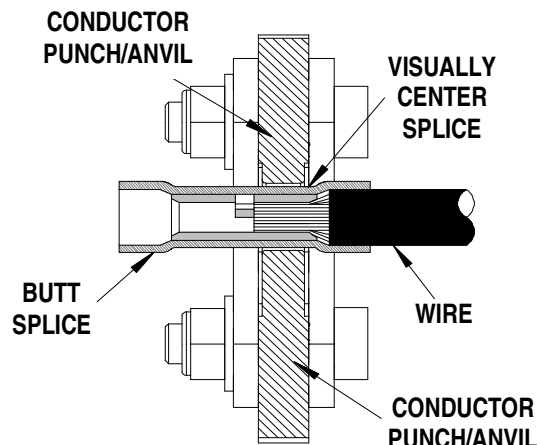

Figure 3

5. When crimping butt splices, insert the wire into the butt splice. Position the splice and the wire in proper nest with conductor crimp on the conductor barrel of the splice. The splice should be approximately centered inside the tooling nests. See Figure 3. Cycle the tool.
6. When crimping parallel splices, insert the 1<sup>st</sup> wire into one end of splice then insert the 2<sup>nd</sup> wire into the opposite end of the parallel splice. This procedure will crimp both wires at the same time. Make sure the wires are fully seated into the parallel splice. Position the splice and the wires in proper nest with conductor crimp on the conductor barrel of the splice. The splice should be approximately centered inside the tooling nests. See Figure 4. Cycle the tool.

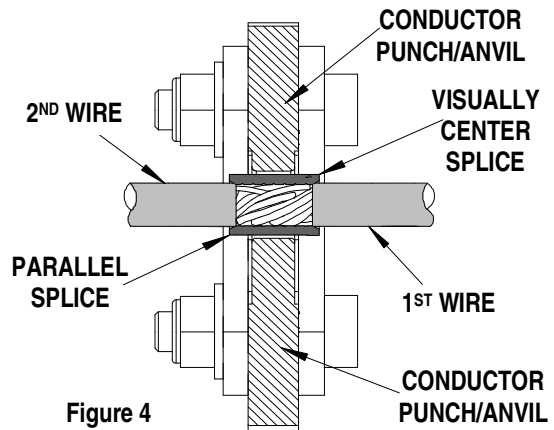

Figure 4

**Note:** Whenever crimping without the locator, make sure the seam of the terminal is oriented up or down in the tool if using unbrazed product, as this will provide higher pull force values.

## Maintenance

It is recommended that each operator of the tool be made aware of, and responsible for, the following maintenance steps:

1. Remove dust, moisture and other contaminants with a clean brush, or soft, lint-free cloth.
2. Do not use any abrasive materials that could damage the tool.
3. Make certain all pins; pivot points and bearing surfaces are protected with a thin coat of high quality machine oil. Do not oil excessively. This hand tool was engineered for durability, but like any fine piece of equipment, it needs cleaning and lubrication for a maximum service life of trouble-free crimping. A light oil, such as 30 weight automotive oil used at the oil points shown in Figure 6, every 5,000 crimps or 3 months will significantly enhance the tool life and ensure a stable calibration.
4. When tool is not in use, keep the handles closed to prevent objects from becoming lodged in the crimping dies, and store the tool in a clean, dry area.

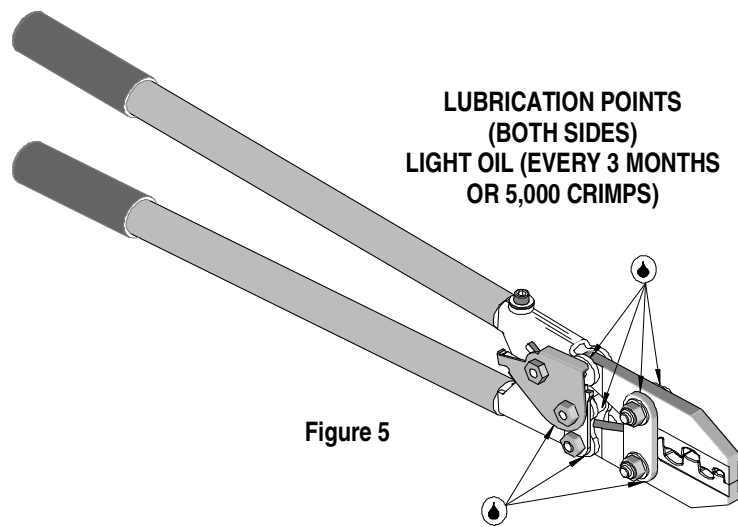

Figure 5

### Miscrimps or Jams

Should this tool ever become stuck or jammed in a partially closed position, **Do Not force the handles open or closed.** The tool will open easily by pushing the ratchet release lever forward. See Figure 6.

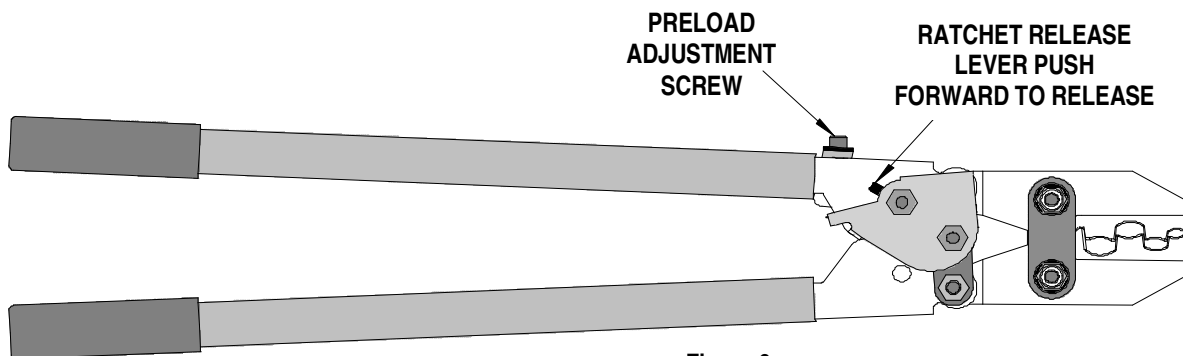

Figure 6

### How to Adjust Tool Preload (See Figure 6 and 7)

Over the life of the tool, it may be necessary to adjust tool handle preload force. Listed below are the steps required to adjust the crimping force of the hand tool to obtain proper crimp conditions:

1. Close the tool handles until jaws are fully closed and not under pressure. Put one handle grip on a weight scale and apply pressure downward against opposite handle. Observe the highest-pressure reading.
2. If tool needs adjustment, turn the preload adjustment screw. To increase preload setting, tighten (CW) the screw slightly, to decrease loosen (CCW) the screw. The preload should be 30-35 LBS.
3. Recheck the preload after making a crimp. Check the crimp specifications after tool handle preload force is adjusted.

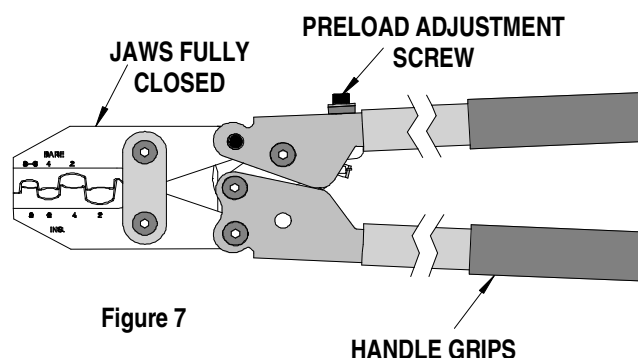
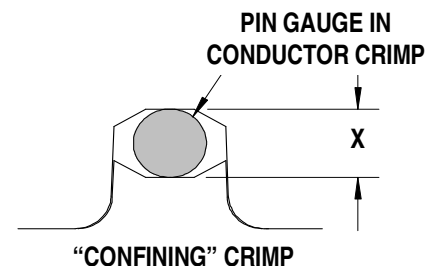

Figure 7

### Tool Calibration

A Certificate of Calibration (see last page) was supplied with the tool. To recalibrate this tool, pin gauge measurements should be taken in each conductor nest and compared to this chart. The tool should be lubricated before recalibration to ensure consistent measurements. Handle preload is factory set to 30-35 LBS. See How to Adjust Tool Preload, see Figure 7 to recalibrate.



Wire Range		"X" Dimension Conductor Crimp		
×AWG	mm <sup>2</sup>	Mean	Go	No Go
8	10.00	.170	.165	.176
6	16.00	.240	.235	.246
4	25.00	.330	.325	.336
2	35.00	.378	.373	.384

× AWG pin gauge readings are taken from nests marked "INS."

## Warranty

This tool is for electrical terminal crimping purposes only. This tool is made of the best quality materials. All vital components are long-life tested. All tools are warranted free of manufacturing defects for a period of **30 days**. Should such a defect occur, we will repair or exchange the tool free of charge. This repair or exchange will not be applicable to alter, misused or damaged tools. This tool is designed for hand use only. Any clamping, fixturing, or use of handle extensions voids this warranty.

Hand held crimping tools are intended for low volume, prototyping, or repair requirements only.

**Caution: Repetitive use of this tool should be avoided.**



**PARTS LIST**

Item	Order No	Description	Quantity
	<b>64001-3900</b>	<b>Hand Crimp Tool</b>	<b>Figure 8</b>
1	63810-0600	17" Handle (OPT #HS-HAND-432)	1
2	64001-3970	Tooling Kit	1
Tooling Kit Only			
3	64001-3901	Conductor Punch/Anvil	1
4	64001-3902	Conductor Punch/Anvil	1
5	64001-3910	Link	2
6	64001-3911	Rocker	1
7	63700-3374	Stripper Bolt	2
8	63700-3375	Nut	2
9	N/A	5/16" - Washer	2**

\*\* The following purchased parts are available from an Industrial supply company such as MSC (1-800-645-7270).

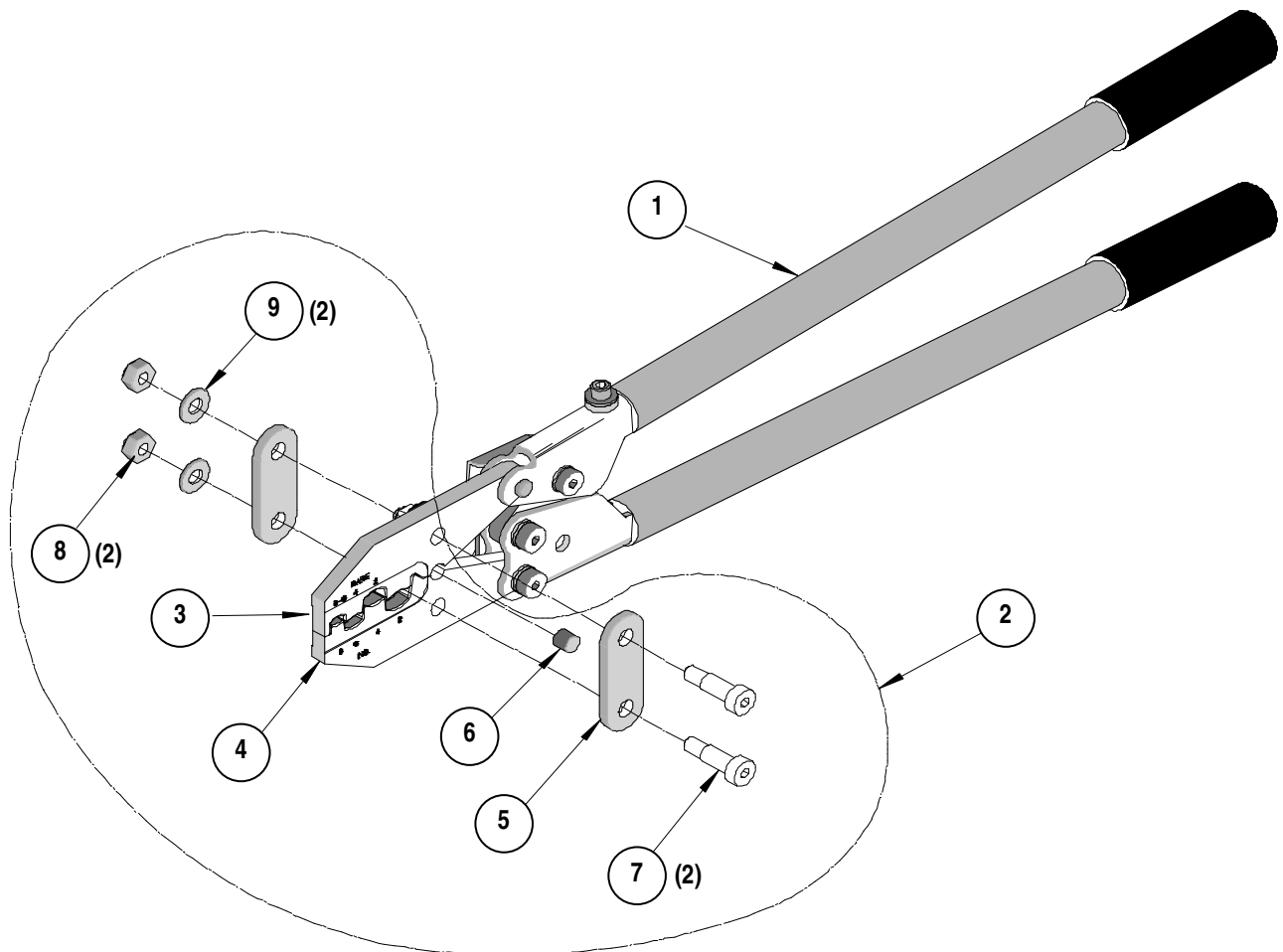
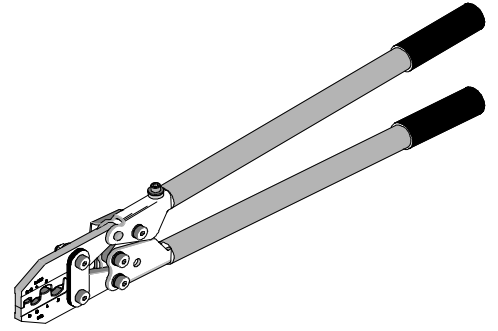

Figure 8





Certificate of Calibration



Tool Order Number \_\_\_\_\_

Tool Eng. Number \_\_\_\_\_

Tool Revision \_\_\_\_\_

Serial Number \_\_\_\_\_

Date of Manufacture \_\_\_\_\_

Handle Load Range; see Tool Preload (page 6). = \_\_\_\_\_

Actual = \_\_\_\_\_

Pin Gauge of Conductor Nest/Nests or Slug height if the nest is the "F" Crimp style.

Range Conductor Nest # 1 = \_\_\_\_\_ Actual = \_\_\_\_\_

Range Conductor Nest # 2 = \_\_\_\_\_ Actual = \_\_\_\_\_

Range Conductor Nest # 3 = \_\_\_\_\_ Actual = \_\_\_\_\_

Range Conductor Nest # 4 = \_\_\_\_\_ Actual = \_\_\_\_\_

Technician \_\_\_\_\_

Date of Calibration \_\_\_\_\_

Calibration should be done every 5,000 cycles or 3 months.  
Tools should be lubricated during this operation.

**Americas Headquarters**  
Lisle, Illinois 60532 U.S.A.  
1-800-78MOLEX  
amerinfo@molex.com

**Far East North Headquarters**  
Yamato, Kanagawa, Japan  
81-462-65-2324  
feninfo@molex.com

**Far East South Headquarters**  
Jurong, Singapore  
65-6-268-6868  
fesinfo@molex.com

**European Headquarters**  
Munich, Germany  
49-89-413092-0  
eurinfo@molex.com

**Corporate Headquarters**  
2222 Wellington Ct.  
Lisle, IL 60532 U.S.A.  
630-969-4550  
Fax: 630-969-1352

Visit our Web site at <http://www.molex.com>



Компания «ЭлектроПласт» предлагает заключение долгосрочных отношений при поставках импортных электронных компонентов на взаимовыгодных условиях!

Наши преимущества:

- Оперативные поставки широкого спектра электронных компонентов отечественного и импортного производства напрямую от производителей и с крупнейших мировых складов;
- Поставка более 17-ти миллионов наименований электронных компонентов;
- Поставка сложных, дефицитных, либо снятых с производства позиций;
- Оперативные сроки поставки под заказ (от 5 рабочих дней);
- Экспресс доставка в любую точку России;
- Техническая поддержка проекта, помощь в подборе аналогов, поставка прототипов;
- Система менеджмента качества сертифицирована по Международному стандарту ISO 9001;
- Лицензия ФСБ на осуществление работ с использованием сведений, составляющих государственную тайну;
- Поставка специализированных компонентов (Xilinx, Altera, Analog Devices, Intersil, Interpoint, Microsemi, Aeroflex, Peregrine, Syfer, Eurofarad, Texas Instrument, Miteq, Cobham, E2V, MA-COM, Hittite, Mini-Circuits, General Dynamics и др.);

Помимо этого, одним из направлений компании «ЭлектроПласт» является направление «Источники питания». Мы предлагаем Вам помощь Конструкторского отдела:

- Подбор оптимального решения, техническое обоснование при выборе компонента;
- Подбор аналогов;
- Консультации по применению компонента;
- Поставка образцов и прототипов;
- Техническая поддержка проекта;
- Защита от снятия компонента с производства.



#### Как с нами связаться

**Телефон:** 8 (812) 309 58 32 (многоканальный)

**Факс:** 8 (812) 320-02-42

**Электронная почта:** [org@eplast1.ru](mailto:org@eplast1.ru)

**Адрес:** 198099, г. Санкт-Петербург, ул. Калинина, дом 2, корпус 4, литера А.