

# Data Sheet

## HAL<sup>®</sup> 1002

Highly Precise Programmable  
Hall-Effect Switch

---

**Copyright, Warranty, and Limitation of Liability**

The information and data contained in this document are believed to be accurate and reliable. The software and proprietary information contained therein may be protected by copyright, patent, trademark and/or other intellectual property rights of Micronas. All rights not expressly granted remain reserved by Micronas.

Micronas assumes no liability for errors and gives no warranty representation or guarantee regarding the suitability of its products for any particular purpose due to these specifications.

By this publication, Micronas does not assume responsibility for patent infringements or other rights of third parties which may result from its use. Commercial conditions, product availability and delivery are exclusively subject to the respective order confirmation.

Any information and data which may be provided in the document can and do vary in different applications, and actual performance may vary over time.

All operating parameters must be validated for each customer application by customers' technical experts. Any new issue of this document invalidates previous issues. Micronas reserves the right to review this document and to make changes to the document's content at any time without obligation to notify any person or entity of such revision or changes. For further advice please contact us directly.

Do not use our products in life-supporting systems, military, aviation, or aerospace applications! Unless explicitly agreed to otherwise in writing between the parties, Micronas' products are not designed, intended or authorized for use as components in systems intended for surgical implants into the body, or other applications intended to support or sustain life, or for any other application in which the failure of the product could create a situation where personal injury or death could occur.

No part of this publication may be reproduced, photocopied, stored on a retrieval system or transmitted without the express written consent of Micronas.

**Micronas Trademarks**

– HAL

**Micronas Patents**

EPO 953 848, EP 0 647 970, EP 1 039 357,  
EP 1 575 013, EP 1 949 034

**Third-Party Trademarks**

All other brand and product names or company names may be trademarks of their respective companies.

## Contents

Page	Section	Title
<b>4</b>	<b>1.</b>	<b>Introduction</b>
4	1.1.	Major Applications
4	1.2.	Features
<b>5</b>	<b>2.</b>	<b>Ordering Information</b>
5	2.1.	Marking Code
5	2.2.	Operating Junction Temperature Range ( $T_J$ )
5	2.3.	Hall Sensor Package Codes
<b>6</b>	<b>3.</b>	<b>Functional Description</b>
6	3.1.	General Function
8	3.2.	Digital Signal Processing and EEPROM
10	3.3.	MODE register
12	3.4.	General Calibration Procedure
13	3.5.	Example: Calibration of a Position Switch
<b>14</b>	<b>4.</b>	<b>Specifications</b>
14	4.1.	Outline Dimensions
16	4.2.	Soldering, Welding and Assembly
16	4.3.	Pin Connections and Short Descriptions
16	4.4.	Dimension of Sensitive Area
16	4.5.	Physical Dimensions
17	4.6.	Absolute Maximum Ratings
18	4.6.1.	Storage and Shelf Life
18	4.7.	Recommended Operating Conditions
19	4.8.	Characteristics
19	4.9.	Magnetic Characteristics
<b>20</b>	<b>5.</b>	<b>Application Notes</b>
20	5.1.	Application Circuit
20	5.2.	Temperature Compensation
21	5.3.	Ambient Temperature
21	5.4.	EMC and ESD
<b>22</b>	<b>6.</b>	<b>Programming</b>
22	6.1.	Definition of Programming Pulses
22	6.2.	Definition of the Telegram
24	6.3.	Telegram Codes
25	6.4.	Number Formats
25	6.5.	Register Information
28	6.6.	Programming Information
<b>29</b>	<b>7.</b>	<b>Data Sheet History</b>

## Highly Precise Programmable Hall-Effect Switch

**Release Note: Revision bars indicate significant changes to the previous edition.**

### 1. Introduction

The HAL1002 is the improved successor of the HAL 1000 Hall switch. The major sensor characteristics, the two switching points  $B_{ON}$  and  $B_{OFF}$ , are programmable for the application. The sensor can be programmed to be unipolar or latching, sensitive to the magnetic north pole or sensitive to the south pole, with normal or with an electrically inverted output signal. Several examples are shown in Fig. 3–4 through Fig. 3–7.

The HAL1002 is based on the HAL83x family and features a temperature-compensated Hall plate with chopped offset compensation, an A/D converter, digital signal processing, a push-pull output stage, an EEPROM memory with redundancy and lock function for the calibration data, a serial interface for programming the EEPROM, and protection devices at all pins. Internal digital signal processing is of great benefit because analog offsets, temperature shifts, and mechanical stress effects do not degrade the sensor accuracy.

The HAL1002 is programmable by modulating the supply voltage. No additional programming pin is needed. Programming is simplified through the use of a 2-point calibration. Calibration is accomplished by adjusting the sensor output directly to the input signal. Individual adjustment of each sensor during the customer's manufacturing process is possible. With this calibration procedure, the tolerances of the sensor, the magnet, and the mechanical positioning can be compensated for the final assembly. This offers a low-cost alternative for all applications that presently require mechanical adjustment or other system calibration.

In addition, the temperature compensation of the Hall IC can be tailored to all common magnetic materials by programming first and second order temperature coefficients of the Hall sensor sensitivity. This enables operation over the full temperature range with constant switching points.

The calculation of the individual sensor characteristics and the programming of the EEPROM memory can easily be done with a PC and the application kit from Micronas.

The sensor is designed and produced in sub-micron CMOS technology for the use in hostile industrial and automotive applications with nominal supply voltage of 5 V in the ambient temperature range from  $-40\text{ }^{\circ}\text{C}$  up to  $150\text{ }^{\circ}\text{C}$ .

The HAL1002 is available in the leaded package TO92UT-2.

### 1.1. Major Applications

Due to the sensor's versatile programming characteristics, the HAL1002 is the optimal system solution for applications which require very precise contactless switching:

- Endpoint detection
- Level switch (e.g. liquid level)
- Electronic fuse (current measurement)

### 1.2. Features

- High-precision Hall switch with programmable switching points and switching behavior
- AEC-Q100 qualified
- EMC and ESD optimized design  
ESD HBM performance  $>7\text{ kV}$
- Switching points programmable from  $-150\text{ mT}$  up to  $150\text{ mT}$  in steps of 0.5% of the magnetic field range
- Multiple programmable magnetic characteristics in a non-volatile memory (EEPROM) with redundancy and lock function
- Temperature characteristics are programmable for matching all common magnetic materials
- Programming through a modulation of the supply voltage
- Operates from  $-40\text{ }^{\circ}\text{C}$  up to  $150\text{ }^{\circ}\text{C}$  ambient temperature
- Operates from 4.5 V up to 8.5 V supply voltage in specification and functions up to 11 V
- Operates with static magnetic fields and dynamic magnetic fields up to 2 kHz
- Magnetic characteristics are extremely robust against mechanical stress effects
- Overvoltage and reverse-voltage protection at all pins
- Short-circuit protected push-pull output

**2. Ordering Information**

**2.1. Marking Code**

The HAL1002 has a marking on the package surface (branded side). This marking includes the name of the sensor and the temperature range.

Type	Temperature Range
	<b>A</b>
HAL1002	1002A

**2.2. Operating Junction Temperature Range (T<sub>J</sub>)**

The Hall sensors from Micronas are specified to the chip temperature (junction temperature T<sub>J</sub>).

**A:** T<sub>J</sub> = -40 °C to +170 °C

The relationship between ambient temperature (T<sub>A</sub>) and junction temperature is explained in Section 5.3. on page 21.

**2.3. Hall Sensor Package Codes**

HALXXXXPA-T

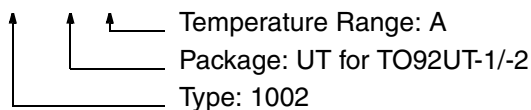

Example: **HAL1002UT-A**

- Type: 1002
- Package: TO92UT
- Temperature Range: T<sub>J</sub> = -40 °C to +170 °C

Hall sensors are available in a wide variety of packaging versions and quantities. For more detailed information, please refer to the brochure: “Hall Sensors: Ordering Codes, Packaging, Handling”.

**3. Functional Description**

**3.1. General Function**

The HAL1002 is a monolithic integrated circuit which provides a digital output signal. The sensor is based on the HAL83x design.

The Hall plate is sensitive to magnetic north and south polarity. The external magnetic field component perpendicular to the branded side of the package generates a Hall voltage. This voltage is converted to a digital value and processed in the Digital Signal Processing Unit (DSP) according to the settings of the EEPROM registers. The function and the parameters for the DSP are explained in Section 3.2. on page 8.

The setting of the LOCK register disables the programming of the EEPROM memory for all time. This register cannot be reset.

As long as the LOCK register is not set, the output characteristic can be adjusted by programming the EEPROM registers. The IC is addressed by modulating the supply voltage (see Fig. 3–1). After detecting a command, the sensor reads or writes the memory and answers with a digital signal on the output pin. The digital output is switched off during the communication.

Internal temperature compensation circuitry and the chopped offset compensation enable the operation over the full temperature range with minimal changes of the switching points. The circuitry also rejects offset shifts due to mechanical stress from the package. The non-volatile memory consists of redundant EEPROM cells. In addition, the HAL1002 is equipped with devices for overvoltage and reverse-voltage protection at all pins.

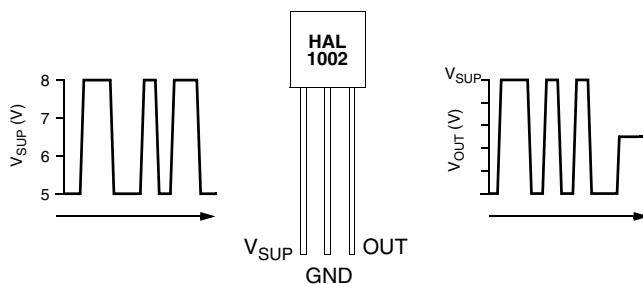

**Fig. 3–1:** Programming with V<sub>SUP</sub> modulation

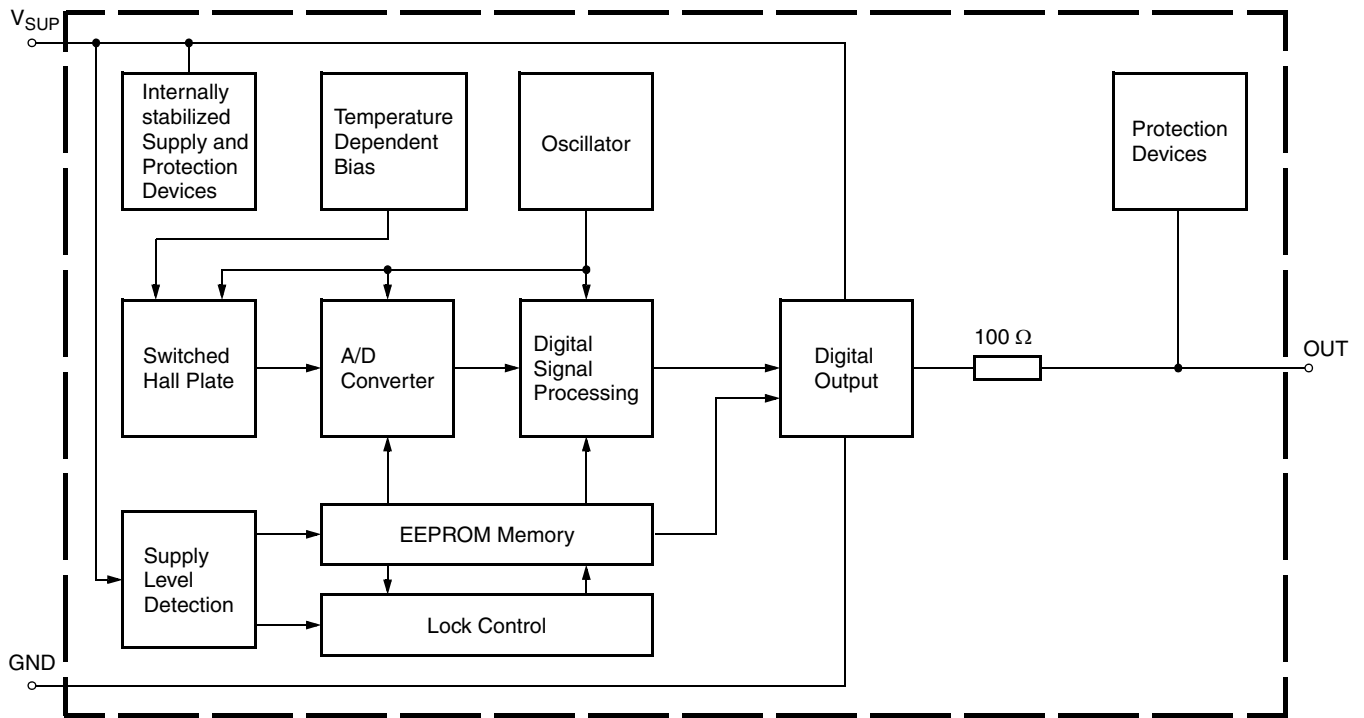

Fig. 3-2: HAL 1002 block diagram

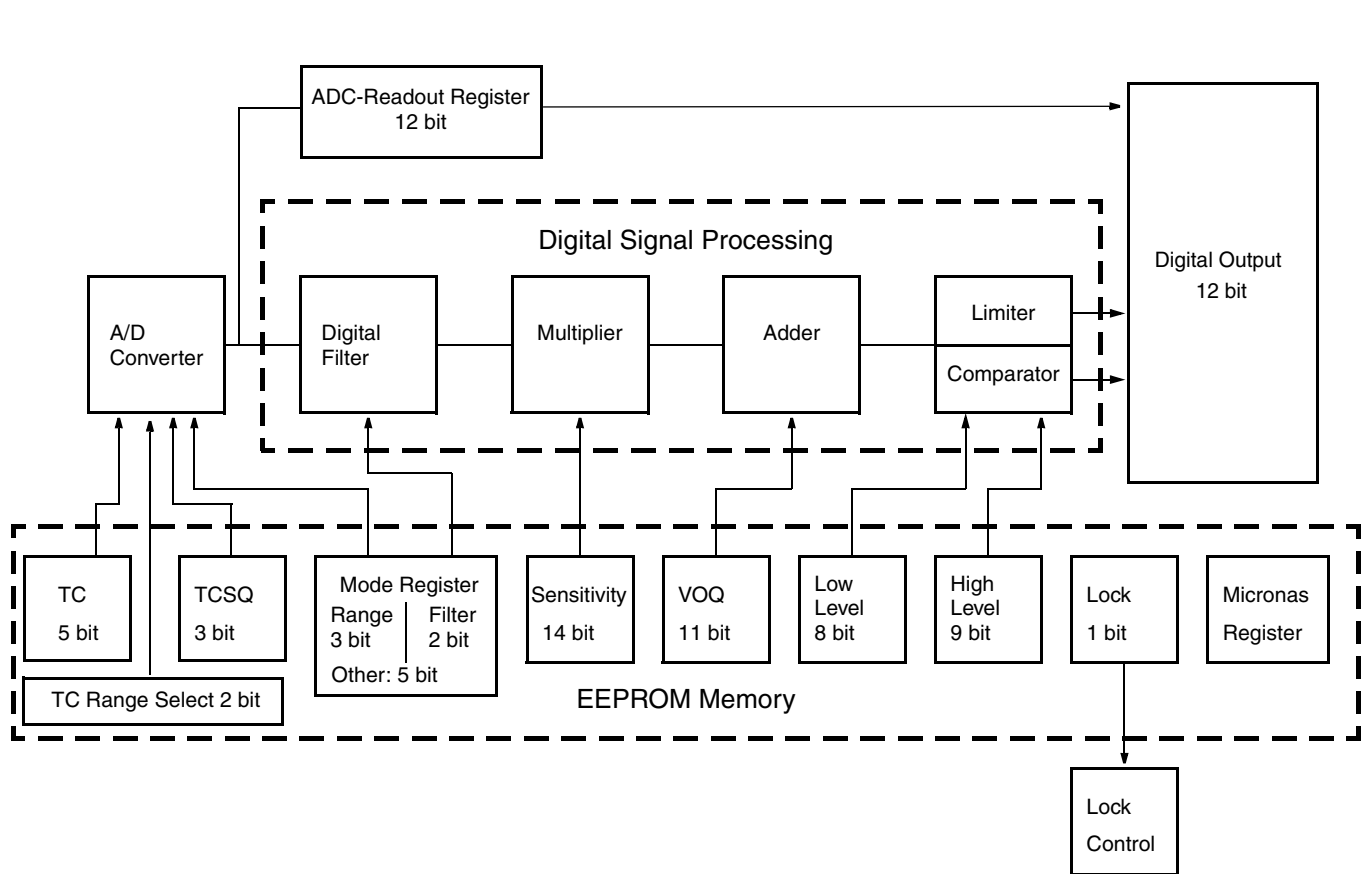

Fig. 3-3: Details of EEPROM Registers and Digital Signal Processing

### 3.2. Digital Signal Processing and EEPROM

The DSP is the main part of the sensor and performs the signal processing. The parameters for the DSP are stored in the EEPROM registers. The details are shown in Fig. 3–3.

#### Terminology:

SENSITIVITY: name of the register or register value

Sensitivity: name of the parameter

#### EEPROM Registers:

The EEPROM registers include three groups:

**Group 1** contains the registers for the adaption of the sensor to the magnetic system: MODE for selecting the magnetic field range and filter frequency, TC and TCSQ for the temperature characteristics of the magnetic sensitivity and thereby for the switching points.

**Group 2** contains the registers for defining the switching points: SENSITIVITY, VOQ, LOW-LEVEL, and HIGH-LEVEL.

The comparator compares the processed signal voltage with the reference values Low-Level and High-Level.

The output switches on (low) if the signal voltage is higher than the High-Level, and switches off (high) if the signal falls below the Low-Level. Several examples of different switching characteristics are shown in Fig. 3–4 to Fig. 3–7.

- The parameter  $V_{OQ}$  (Output Quiescent Voltage) corresponds to the signal voltage at  $B = 0$  mT.
- The parameter Sensitivity defines the magnetic sensitivity:

$$\text{Sensitivity} = \frac{\Delta V_{\text{Signal}}}{\Delta B}$$

- The signal voltage can be calculated as follows:

$$V_{\text{Signal}} \sim \text{Sensitivity} \times B + V_{OQ}$$

Therefore, the switching points are programmed by setting the SENSITIVITY, VOQ, LOW-LEVEL, and HIGH-LEVEL registers. The available Micronas software calculates the best parameter set respecting the ranges of each register.

**Group 3** contains the Micronas registers and LOCK for the locking of all registers. The Micronas registers are programmed and locked during production and are read-only for the customer. These registers are used for oscillator frequency trimming, A/D converter offset compensation, and several other special settings.



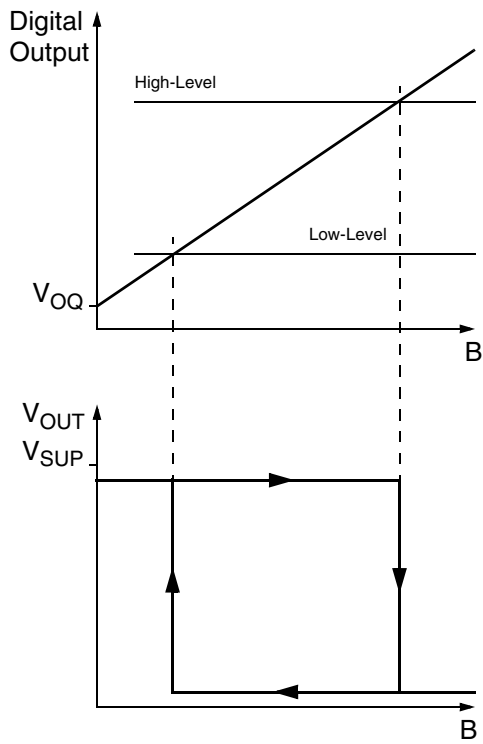

Fig. 3-4: HAL 1002 with unipolar behavior

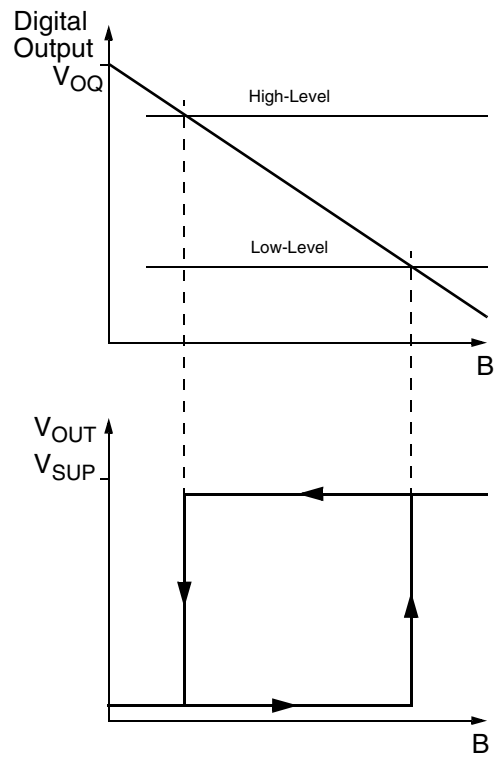

Fig. 3-6: HAL 1002 with unipolar inverted behavior

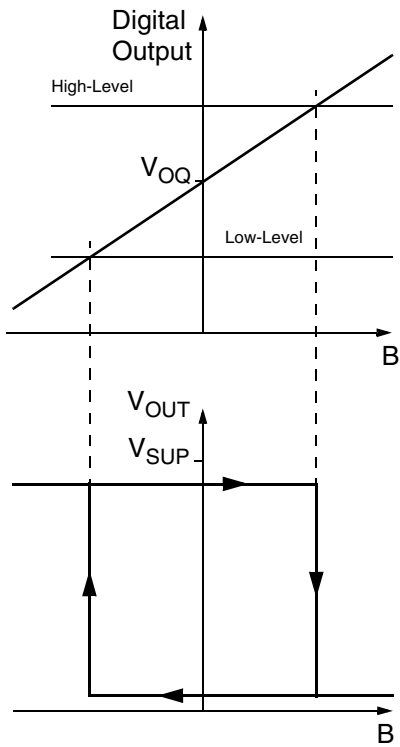

Fig. 3-5: HAL 1002 with latching behavior

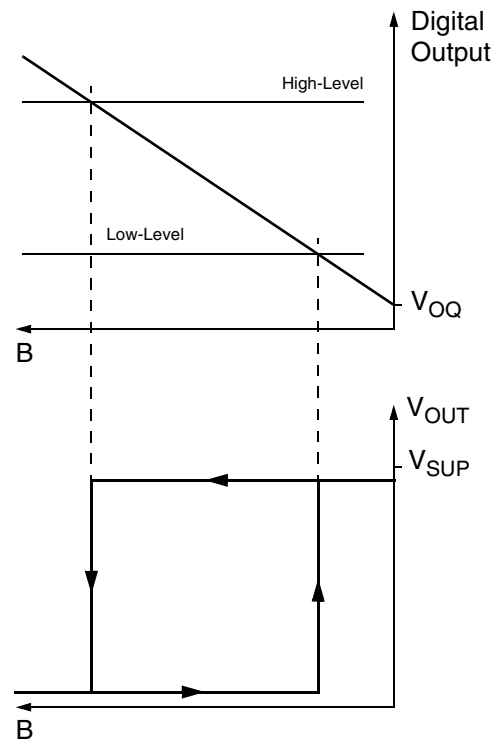

Fig. 3-7: HAL 1002 with unipolar behavior sensitive to the other magnetic polarity

### 3.3. MODE register

The MODE register contains all bits used to configure the A/D converter and the different output modes.

MODE										
Bit Number	9	8	7	6	5	4	3	2	1	0
Parameter	RANGE	Signed Offset Correction	OUTPUTMODE			FILTER		RANGE (together with bit 9)		Offset Correction

**Table 3–1:** MODE register of the HAL 1002

#### Offset Correction

The Offset Correction function can be used for handling unipolar magnetic fields or systems with high magnetic offset and small magnetic amplitudes. The OFFSET CORRECTION register allows to adjust the digital offset after the built-in A/D-converter. The digital offset can be programmed to 50%, 0% and -50% of A/D-converter full-scale range.

Offset Correction	OFFSET CORRECTION	
	MODE [8]	MODE [0]
50%	0	1
0	0	0
-50%	1	1

For Offset correction please contact Micronas service.

#### Magnetic Range

The RANGE bits define the magnetic field range of the A/D converter.

Magnetic Range	RANGE	
	MODE [9]	MODE [2:1]
15 mT	1	00
30 mT	0	00

**Table 3–2:** Magnetic Range

Magnetic Range	RANGE	
	MODE [9]	MODE [2:1]
40 mT	1	10
60 mT	0	01
80 mT	0	10
100 mT	0	11
150 mT	1	11

**Table 3–2:** Magnetic Range

#### Filter

The FILTER bits define the -3 dB frequency of the digital low pass filter.

-3 dB Frequency	MODE [4:3]
80 Hz	00
500 Hz	10
1 kHz	11
2 kHz	01

**Output Format**

The OUTPUTMODE bits define the different output modes of HAL1002.

Output Format	MODE [7:5]
Switch (positive polarity)	100
Switch (negative polarity)	101

**Table 3–3:** OUTPUTMODE

**TC Register**

The temperature dependence of the magnetic sensitivity can be adapted to different magnetic materials in order to compensate for the change of the magnetic strength with temperature. The adaptation is done by programming the TC (Temperature Coefficient) and the TCSQ registers (Quadratic Temperature Coefficient). Thereby, the slope and the curvature of the temperature dependence of the magnetic sensitivity can be matched to the magnet and the sensor assembly. As a result, the output voltage characteristic can be constant over the full temperature range. The sensor can compensate for linear temperature coefficients ranging from about – 3100 ppm/K up to 1000 ppm/K and quadratic coefficients from about -7 ppm/K<sup>2</sup> to 2 ppm/K<sup>2</sup>. The full TC range is separated in the following four groups:

TC-Range [ppm/k]	GROUP
–3100 to –1800	0
–1750 to –550	2
–500 to +450 (default value)	1
+450 to +1000	3

TC (5 bit) and TCSQ (3 bit) have to be selected individually within each of the four ranges. For example 0 ppm/k requires TC-Range = 1, TC = 15 and TCSQ = 1. Please refer to Section 5.2. on page 20 for more details.

**Sensitivity Register**

The SENSITIVITY register contains the parameter for the multiplier in the DSP. Sensitivity is programmable between –4 and 4 in steps of 0.00049. Sensitivity = 1 corresponds to an increase of the signal voltage by V<sub>SUP</sub> if the ADC-READOUT increases by 2048.

**VOQ Register**

The VOQ register contains the parameter for the adder in the DSP. V<sub>OQ</sub> is the signal voltage without external magnetic field (B = 0 mT, respectively ADC-READOUT = 0) and programmable from –V<sub>SUP</sub> up to V<sub>SUP</sub>. For V<sub>SUP</sub> = 5 V, the register can be changed in steps of 4.9 mV.

**Note:** If V<sub>OQ</sub> is programmed to a negative voltage, the maximum signal voltage is limited to:

$$V_{Signal\ max} = V_{OQ} + V_{SUP}$$

**Reference Level Register**

The LOW-LEVEL and HIGH-LEVEL registers contain the reference values of the comparator.

The Low-Level is programmable between 0 V and V<sub>SUP</sub>/2. The register can be changed in steps of 2.44 mV. The High-Level is programmable between 0 V and V<sub>SUP</sub> in steps of 2.44 mV.

The four parameters Sensitivity, V<sub>OQ</sub>, Low-Level, and High-Level define the switching points B<sub>ON</sub> and B<sub>OFF</sub>. For calibration in the system environment, a 2-point adjustment procedure is recommended (see Section 3.4.). The suitable parameter set for each sensor can be calculated individually by this procedure.

**GP Register**

This register can be used to store information, like production date or customer serial number. Micronas will store production lot number, wafer number and x,y coordinates in registers GP1 to GP3. The total register contains four blocks with a length of 13 bit each. The customer can read out this information and store it in his production data base for reference or he can store own production information instead.

**Note:** This register is not a guarantee for traceability because readout of registers is not possible after locking the IC.

To read/write this register it is mandatory to read/write all GP register one after the other starting with GP0. In case of a writing the registers it necessary to first write all registers followed by one store sequence at the end. Even if only GP0 should be changed all other GP registers must first be read and the read out data must be written again to these registers.

**LOCK Register**

By setting the LSB of this 2-bit register, all registers will be locked, and the sensor will no longer respond to any supply voltage modulation. This bit is active after the first power-off and power-on sequence after setting the LOCK bit. After locking of sensor is active, it will no longer respond to power supply modulation.

---

**Warning: This register cannot be reset!**

---

**ADC-READOUT Register**

This 14-bit register delivers the actual digital value of the applied magnetic field after filtering but before the signal processing. This register can be read out and is the basis for the calibration procedure of the sensor in the system environment.

**D/A-READOUT**

This 14-bit register delivers the actual digital value of the applied magnetic field after the signal processing.

This register can be read out and is the basis for the calibration procedure of the sensor in the system environment.

---

**Note:** The MSB and LSB are reversed compared with all the other registers. Please reverse this register after readout.

---



---

**Note:** During calibration it is mandatory to select the Analog Output as output format. The D/A-Readout register can be read out only in the output mode. For all other modes the result read back from the sensor will be a 0. After the calibration the output format can than easily be switched to the wanted output mode.

---

**3.4. General Calibration Procedure**

For calibration in the system environment, the application kit from Micronas is recommended. It contains the hardware for the generation of the serial telegram for programming and the corresponding software for the input or calculation of the register values.

In this section, the programming of the sensor using this tool is explained. Please refer to Section 5. on page 24 for information about programming without this tool.

For the individual calibration of each sensor in the customer’s application, a two-point adjustment is recommended (see Fig. 3–1 for an example). When using the application kit, the calibration can be done in three steps:

**Step 1: Input of the registers which need not be adjusted individually**

The magnetic circuit, the magnetic material with its temperature characteristics, and the filter frequency, are given for this application.

Therefore, the values of the following registers should be identical for all sensors in the application.

- FILTER  
(according to maximum signal frequency)  
The 500 Hz range is recommended for highest accuracy.
- RANGE  
(according to the maximum magnetic field at the sensor position)
- TC and TCSQ  
(depends on the material of the magnet and the other temperature dependencies of the application)

Write the appropriate settings into the HAL1002 registers.

**Step 2: Calculation of the Sensor Parameters**

Fig. 3–1 shows the typical characteristics for a contactless switch. There is a mechanical range where the sensor must be switched high and where the sensor must be switched low.

Set the system to the calibration point where the sensor output must be high, and press the key “Readout B<sub>OFF</sub>”. The result is the corresponding ADC-READOUT value.

---

**Note:** The magnetic south pole on the branded side generates negative ADC-READOUT values, the north polarity positive values.

---

Then, set the system to the calibration point where the sensor output must be low, press the key “Readout B<sub>ON</sub>” and get the second ADC-READOUT value.

Now, adjust the hysteresis to the desired value. The hysteresis is the difference between the switching points and suppresses oscillation of the output signal. With 100% hysteresis, the sensor will switch low and high exactly at the calibration points. A lower value will adjust the switching points closer together. Fig. 3–1 shows an example with 80% hysteresis.

By pressing the key “calibrate and store”, the software will calculate the corresponding parameters for Sensitivity, VOQ, Low-Level, High-Level and stores these values in the EEPROM.

This calibration must be done individually for each sensor.

The sensor is now calibrated for the customer application. However, the programming can be changed again and again if necessary.

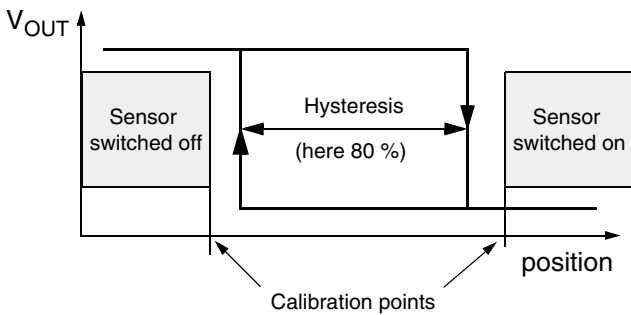

Fig. 3–1: Characteristics of a position switch

**Step 3: Locking the Sensor**

The last step is activating the LOCK function with the “lock” key. The sensor is now locked and does not respond to any programming or reading commands.

**Warning: The LOCK register cannot be reset!**

**3.5. Example: Calibration of a Position Switch**

The following description explains the calibration procedure using a position switch as an example:

- The mechanical switching points are given.
- temperature coefficient of the magnet:  $-500 \text{ ppm/K}$

**Step 1: Input of the registers which need not be adjusted individually**

The register values for the following registers are given for all sensors in the application:

- FILTER  
Select the filter frequency: 500 Hz
- RANGE  
Select the magnetic field range: 30 mT
- TC  
For this magnetic material: 6
- TCSQ  
For this magnetic material: 14

Enter these values in the software and use the “write and store” command to store these values permanently in the registers.

**Step 2: Calculation of the Sensor Parameters**

Set the system to the calibration point where the sensor output must be high and press “Readout B<sub>OFF</sub>”.

Set the system to the calibration point where the sensor output must be low and press “Readout B<sub>ON</sub>”.

Now, adjust the hysteresis to 80% and press the key “calibrate and store”.

**Step 3: Locking the Sensor**

The last step is activating the LOCK function with the “LOCK” command. The sensor is now locked and does not respond to any programming or reading commands. Please note that the LOCK function becomes effective after power-down and power-up of the Hall-IC.

**Warning: The LOCK register cannot be reset!**

4. Specifications

4.1. Outline Dimensions

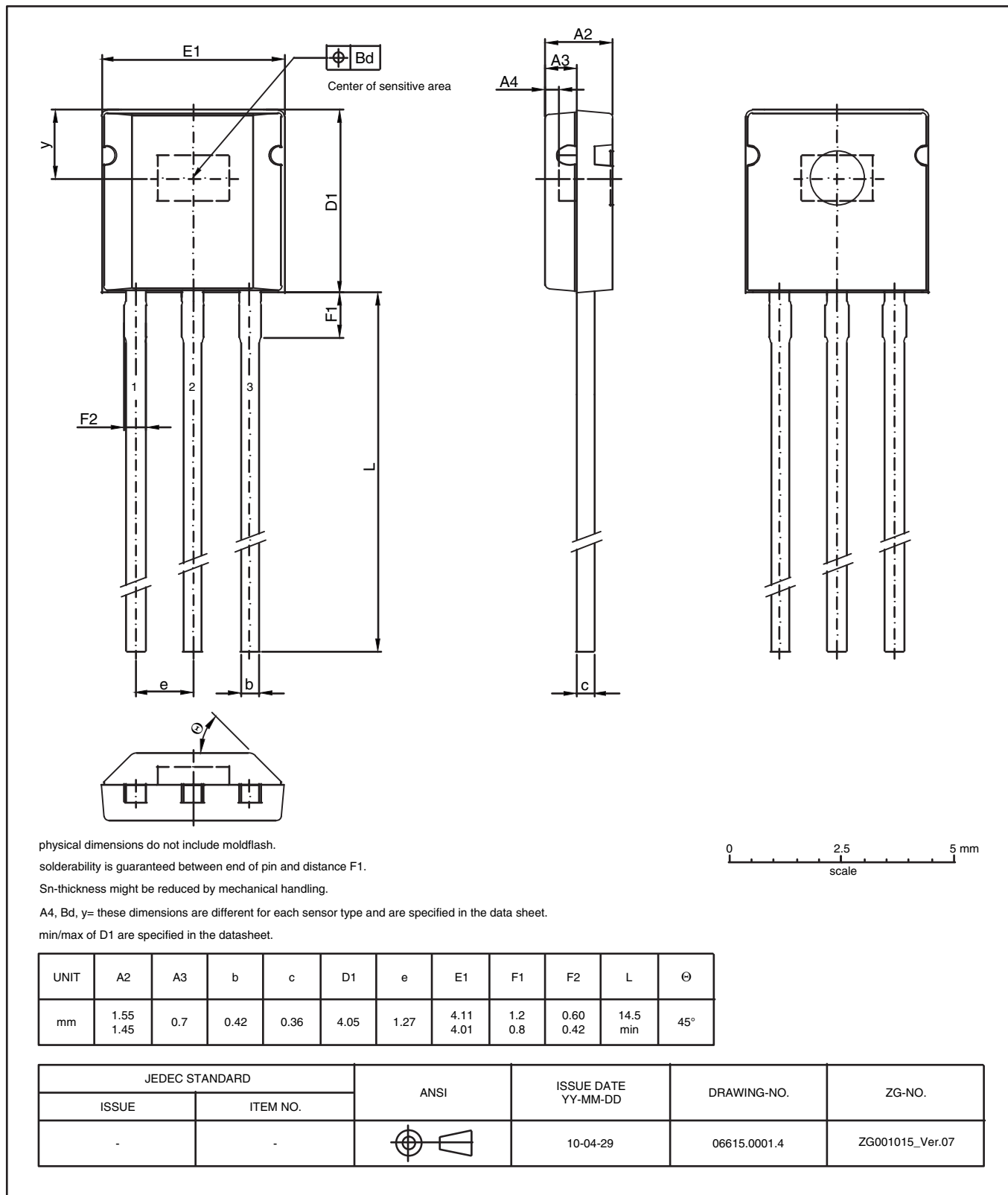
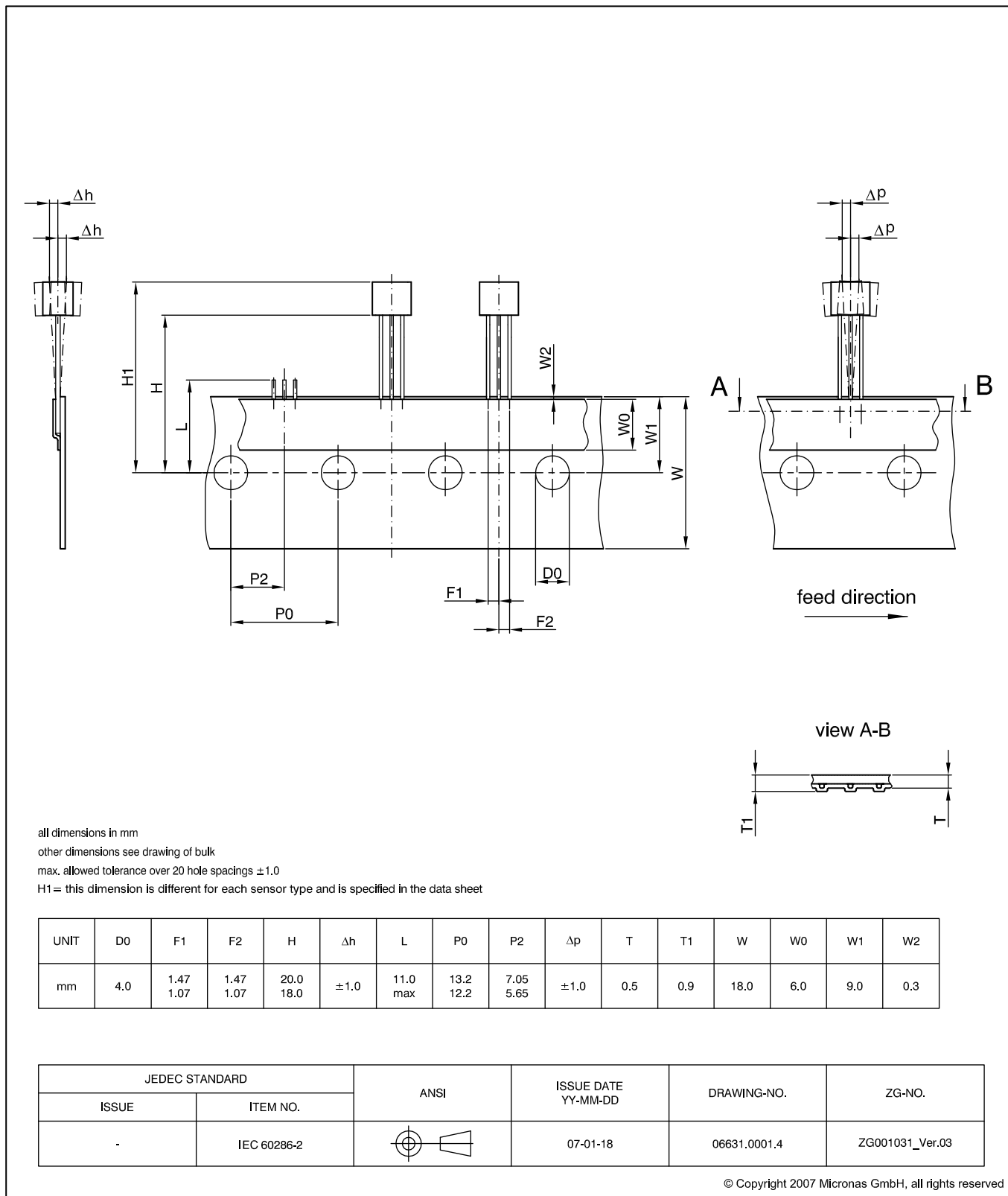

Fig. 4-1:  
**TO92UT-2** Plastic Transistor Standard UT package, 3 leads  
 Weight approximately 0.12 g



**Fig. 4-2:**  
**TO92UA/UT: Dimensions ammpack inline, not spread**

## 4.2. Soldering, Welding and Assembly

Please check the Micronas Document “Guidelines for the Assembly of HAL Packages” for further information about solderability, welding, assembly, and second-level packaging. The document is available on the Micronas website or on the service portal.

## 4.3. Pin Connections and Short Descriptions

Pin No.	Pin Name	Short Description
1	V <sub>SUP</sub>	Supply Voltage and Programming Pin
2	GND	Ground
3	OUT	Push-Pull Output and Selection Pin

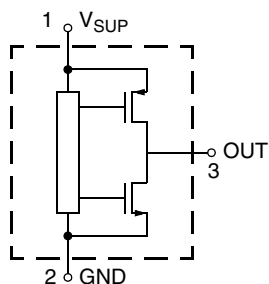

**Fig. 4-3:** Pin configuration

## 4.4. Dimension of Sensitive Area

0.25 mm x 0.25 mm

## 4.5. Physical Dimensions

	TO92UT-1/-2
A4	0.3 mm nominal
Bd	0.3 mm
D1	4.05 mm ± 0.05 mm
H1	min. 22.0 mm max. 24.1 mm
y	1.5 mm nominal



#### 4.6. Absolute Maximum Ratings

Stresses beyond those listed in the “Absolute Maximum Ratings” may cause permanent damage to the device. This is a stress rating only. Functional operation of the device at these conditions is not implied. Exposure to absolute maximum rating conditions for extended periods will affect device reliability.

This device contains circuitry to protect the inputs and outputs against damage due to high static voltages or electric fields; however, it is advised that normal precautions be taken to avoid application of any voltage higher than absolute maximum-rated voltages to this circuit.

All voltages listed are referenced to ground (GND).

Symbol	Parameter	Pin No.	Min.	Max.	Unit	Condition
$V_{SUP}$	Supply Voltage	1	-8.5	11	V	$t < 96 \text{ h}^3$
$V_{SUP}$	Supply Voltage	1	-16	16	V	$t < 1 \text{ h}^3$
$V_{OUT}$	Output Voltage	3	-5	16	V	
$V_{OUT} - V_{SUP}$	Excess of Output Voltage over Supply Voltage	3,1	-	2	V	
$I_{OUT}$	Continuous Output Current	3	-10	10	mA	
$t_{Sh}$	Output Short Circuit Duration	3	-	10	min	
$V_{ESD}$	ESD Protection <sup>1)</sup>	1 3	-8.0 -7.5	8.0 7.5	kV	
$T_J$	Junction Temperature under bias <sup>2)</sup>		-50	190	°C	
<sup>1)</sup> AEC-Q100-002 (100 pF and 1.5 kΩ) <sup>2)</sup> For 96 h - Please contact Micronas for other temperature requirements <sup>3)</sup> No cumulated stress						

#### 4.6.1. Storage and Shelf Life

The permissible storage time (shelf life) of the sensors is unlimited, provided the sensors are stored at a maximum of 30 °C and a maximum of 85% relative humidity. At these conditions, no Dry Pack is required.

Solderability is guaranteed for two years from the date code on the package.

#### 4.7. Recommended Operating Conditions

Functional operation of the device beyond those indicated in the “Recommended Operating Conditions/Characteristics” is not implied and may result in unpredictable behavior, reduce reliability and lifetime of the device.

All voltages listed are referenced to ground (GND).

Symbol	Parameter	Pin No.	Min.	Typ.	Max.	Unit	Condition
V <sub>SUP</sub>	Supply Voltage	1	4.5	5	8.5	V	
I <sub>OUT</sub>	Continuous Output Current	3	-1.2	-	1.2	mA	
R <sub>L</sub>	Load Resistor	3	5.0	10	-	kΩ	Can be pull-up or pull-down resistor (analog output only)
C <sub>L</sub>	Load Capacitance	3	0.33	100	1000	nF	
N <sub>PRG</sub>	Number of EEPROM Programming Cycles	-	-	-	100	cycles	0°C < T <sub>amb</sub> < 55°C
T <sub>J</sub>	Junction Temperature Range <sup>1)</sup>	-	-40 -40 -40	- - -	125 150 170	°C °C °C	for 8000 h <sup>2)</sup> for 2000 h <sup>2)</sup> for 1000 h <sup>2)</sup>

<sup>1)</sup> Depends on the temperature profile of the application. Please contact Micronas for life time calculations.

<sup>2)</sup> Time values are not cumulative

#### 4.8. Characteristics

at  $T_J = -40\text{ °C}$  to  $+170\text{ °C}$ ,  $V_{SUP} = 4.5\text{ V}$  to  $8.5\text{ V}$ , after programming and locking of the device, at Recommended Operation Conditions if not otherwise specified in the column "Conditions".  
Typical Characteristics for  $T_J = 25\text{ °C}$  and  $V_{SUP} = 5\text{ V}$ .

Symbol	Parameter	Pin No.	Min.	Typ.	Max.	Unit	Conditions
$I_{DD}$	Supply Current over Temperature Range	1		7	10	mA	
$V_{OUTH}$	Output High Voltage	3	4.65	4.8		V	$V_{SUP} = 5\text{ V}$ , $-1\text{ mA} \leq I_{OUT} \leq 1\text{ mA}$
$V_{OUTL}$	Output Low Voltage	3		0.2	0.35	V	$V_{SUP} = 5\text{ V}$ , $-1\text{ mA} \leq I_{OUT} \leq 1\text{ mA}$
$f_{ADC}$	Internal ADC Frequency	–	120	128	140	kHz	$T_J = 25\text{ °C}$
$f_{ADC}$	Internal ADC Frequency over Temperature Range	–	110	128	150	kHz	$V_{SUP} = 5\text{ V}$
$t_{r(O)}$	Response Time of Output	3	–	5 4 2 1	10 8 4 2	ms ms ms ms	3 dB Filter frequency = 80 Hz 3 dB Filter frequency = 160 Hz 3 dB Filter frequency = 500 Hz 3 dB Filter frequency = 2 kHz $C_L = 10\text{ nF}$ , time from 10% to 90% of final output voltage for a steplike signal $B_{step}$ from 0 mT to $B_{max}$
$t_{d(O)}$	Delay Time of Output	3		0.1	0.5	ms	$C_L = 10\text{ nF}$
$t_{POD}$	Power-Up Time (Time to reach stabilized Output Voltage)			6 5 3 2	11 9 5 3	ms ms ms ms	3 dB Filter frequency = 80 Hz 3 dB Filter frequency = 160 Hz 3 dB Filter frequency = 500 Hz 3 dB Filter frequency = 2 kHz $C_L = 10\text{ nF}$ , 90% of $V_{OUT}$
BW	Small Signal Bandwidth (–3 dB)	3	–	2	–	kHz	$B_{AC} < 10\text{ mT}$ ; 3 dB Filter frequency = 2 kHz
$R_{thja}$ $R_{thjc}$ $R_{thjs}$	Thermal Resistance Junction to Ambient Junction to Case Junction to Solder Point	– – –	– – –	– – –	235 61 159	K/W	measured on a 1s0p board measured on a 1s0p board measured on a 1s1p board
$B_{ON\_OFF\_res}$	Programming Resolution			12		bit	including sign bit
$B_{ON\_OFF\_acc}$	Threshold Accuracy		–0.1		+0.1	%	at $T_J = 25\text{ °C}$ based on characterization
$B_{ON\_OFF\_acc}$	Threshold Accuracy		–4		+4	%	over operating temperature range based on characterization

#### 4.9. Magnetic Characteristics

at  $T_J = -40\text{ °C}$  to  $+170\text{ °C}$ ,  $V_{SUP} = 4.5\text{ V}$  to  $8.5\text{ V}$ ,  $GND = 0\text{ V}$  after programming and locking, at Recommended Operation Conditions if not otherwise specified in the column "Conditions".  
Typical Characteristics for  $T_J = 25\text{ °C}$  and  $V_{SUP} = 5\text{ V}$ .

Symbol	Parameter	Pin No.	Min.	Typ.	Max.	Unit	Test Conditions
$B_{Offset}$	Magnetic Offset	3	–0.5	0	0.5	mT	$B = 0\text{ mT}$ , $I_{OUT} = 0\text{ mA}$ , $T_J = 25\text{ °C}$ , unadjusted sensor
$\Delta B_{Offset}$	Magnetic Offset Drift		–200	0	200	$\mu\text{T}$	$B = 0\text{ mT}$ , $I_{OUT} = 0\text{ mA}$ $V_{SUP} = 5\text{ V}$ ; 60 mT range, 3db frequency = 500 Hz, TC = 15, TCSQ = 1, TC-Range = 1 –0.65 < sensitivity < 0.65

5. Application Notes

5.1. Application Circuit

For EMC protection, it is recommended to connect one ceramic 100 nF capacitor between ground and the supply voltage, and between ground and the output pin.

Please note that during programming, the sensor will be supplied repeatedly with the programming voltage of 12.5 V for 100 ms. All components connected to the  $V_{SUP}$  line at this time must be able to resist this voltage.

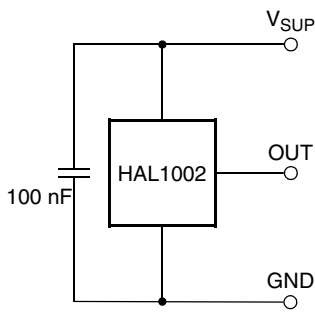

Fig. 5-1: Recommended application circuit

For application circuits for high supply voltages, such as 24 V, please contact the Micronas application service.

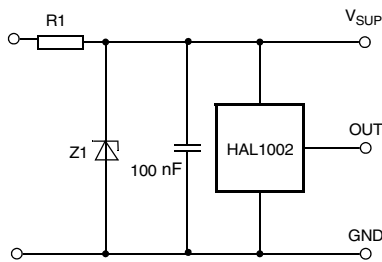

Fig. 5-2: Example for an application circuit for high supply voltage

5.2. Temperature Compensation

The relationship between the temperature coefficient of the magnet and the corresponding TC and TCSQ codes for linear compensation is given in the following table. In addition to the linear change of the magnetic field with temperature, the curvature can be adjusted as well. For this purpose, other TC and TCSQ combinations are required which are not shown in the table. Please contact Micronas for more detailed information on this higher order temperature compensation.

The HAL83x and HAL1002 contain the same temperature compensation circuits. If an optimal setting for the HAL83x is already available, the same settings may be used for the HAL1002.

Temperature Coefficient of Magnet (ppm/K)	TC-Range	TC	TCSQ
1075	3	31	7
1000	3	28	1
900	3	24	0
750	3	16	2
675	3	12	2
575	3	8	2
450	3	4	2
400	1	31	0
250	1	24	1
150	1	20	1
50	1	16	2
0	1	15	1
-100	1	12	0
-200	1	8	1
-300	1	4	4
-400	1	0	7
-500	1	0	0
-600	2	31	2
-700	2	28	1
-800	2	24	3
-900	2	20	6
-1000	2	16	7

Temperature Coefficient of Magnet (ppm/K)	TC-Range	TC	TCSQ
-1100	2	16	2
-1200	2	12	5
-1300	2	12	0
-1400	2	8	3
-1500	2	4	7
-1600	2	4	1
-1700	2	0	6
-1800	0	31	6
-1900	0	28	7
-2000	0	28	2
-2100	0	24	6
-2200	0	24	1
-2400	0	20	0
-2500	0	16	5
-2600	0	14	5
-2800	0	12	1
-2900	0	8	6
-3000	0	8	3
-3100	0	4	7
-3300	0	4	1
-3500	0	0	4

**Note:** The above table shows only some approximate values. Micronas recommends to use the TC-Calc software to find optimal settings for temperature coefficients. Please contact Micronas for more detailed information.

### 5.3. Ambient Temperature

Due to the internal power dissipation, the temperature on the silicon chip (junction temperature  $T_J$ ) is higher than the temperature outside the package (ambient temperature  $T_A$ ).

$$T_J = T_A + \Delta T$$

At static conditions and continuous operation, the following equation applies:

$$\Delta T = I_{SUP} \times V_{SUP} \times R_{thJ}$$

For typical values, use the typical parameters. For worst case calculation, use the max. parameters for  $I_{SUP}$  and  $R_{th}$ , and the max. value for  $V_{SUP}$  from the application.

For  $V_{SUP} = 5.5$  V,  $R_{th} = 235$  K/W, and  $I_{SUP} = 10$  mA, the temperature difference  $\Delta T = 12.93$  K.

For all sensors, the junction temperature  $T_J$  is specified. The maximum ambient temperature  $T_{Amax}$  can be calculated as:

$$T_{Amax} = T_{Jmax} - \Delta T$$

### 5.4. EMC and ESD

Please contact Micronas for the detailed investigation reports with the EMC and ESD results.

**6. Programming**

**6.1. Definition of Programming Pulses**

The sensor is addressed by modulating a serial telegram on the supply voltage. The sensor answers with a serial telegram on the output pin.

The bits in the serial telegram have a different bit time for the  $V_{SUP}$ -line and the output. The bit time for the  $V_{SUP}$ -line is defined through the length of the Sync Bit at the beginning of each telegram. The bit time for the output is defined through the Acknowledge Bit.

A logical “0” is coded as no voltage change within the bit time. A logical “1” is coded as a voltage change between 50% and 80% of the bit time. After each bit, a voltage change occurs.

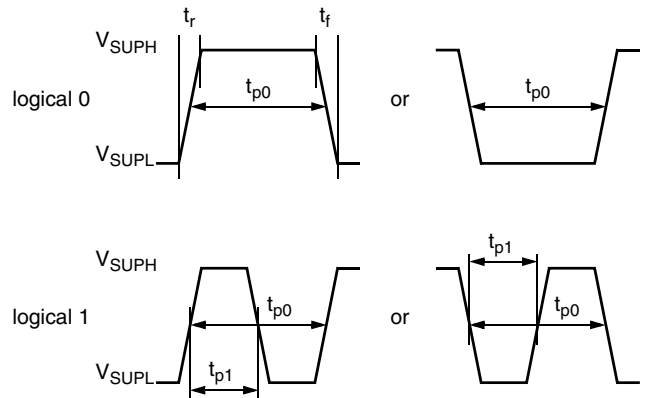

**Fig. 6–1:** Definition of logical 0 and 1 bit

**6.2. Definition of the Telegram**

Each telegram starts with the Sync Bit (logical 0), 3 bits for the Command (COM), the Command Parity Bit (CP), 4 bits for the Address (ADR), and the Address Parity Bit (AP).

There are 4 kinds of telegrams:

- Write a register (see Fig. 6–2)  
After the AP Bit, follow 14 Data Bits (DAT) and the Data Parity Bit (DP). If the telegram is valid and the command has been processed, the sensor answers with an Acknowledge Bit (logical 0) on the output.
- Read a register (see Fig. 6–3)  
After evaluating this command, the sensor answers with the Acknowledge Bit, 14 Data Bits, and the Data Parity Bit on the output.
- Programming the EEPROM cells (see Fig. 6–4)  
After evaluating this command, the sensor answers with the Acknowledge Bit. After the delay time  $t_w$ , the supply voltage rises up to the programming voltage.
- Activate a sensor (see Fig. 6–5)  
If more than one sensor is connected to the supply line, selection can be done by first deactivating all sensors. The output of all sensors have to be pulled to ground. With an Activate pulse on the appropriate output pin, an individual sensor can be selected. All following commands will only be accepted from the activated sensor.

**Table 6–1: Telegram parameters**

Symbol	Parameter	Pin	Min.	Typ.	Max.	Unit	Remarks
$V_{SUPL}$	Supply Voltage for Low Level during Programming	1	5	5.6	6	V	
$V_{SUPH}$	Supply Voltage for High Level during Programming	1	6.8	8.0	8.5	V	
$t_r$	Rise time	1	—	—	0.05	ms	
$t_f$	Fall time	1	—	—	0.05	ms	
$t_{p0}$	Bit time on $V_{SUP}$	1	1.7	1.75	1.9	ms	$t_{p0}$ is defined through the Sync Bit
$t_{pOUT}$	Bit time on output pin	3	2	3	4	ms	$t_{pOUT}$ is defined through the Acknowledge Bit
$t_{p1}$	Duty-Cycle Change for logical 1	1, 3	50	65	80	%	% of $t_{p0}$ or $t_{pOUT}$
$V_{SUPPROG}$	Supply Voltage for Programming the EEPROM	1	12.4	12.5	12.6	V	
$t_{PROG}$	Programming Time for EEPROM	1	95	100	105	ms	
$t_{rp}$	Rise time of programming voltage	1	0.2	0.5	1	ms	
$t_{fp}$	Fall time of programming voltage	1	0	—	1	ms	
$t_w$	Delay time of programming voltage after Acknowledge	1	0.5	0.7	1	ms	
$V_{act}$	Voltage for an Activate pulse	3	3	4	5	V	
$t_{act}$	Duration of an Activate pulse	3	0.05	0.1	0.2	ms	
$V_{out,deact}$	Output voltage after deactivate command	3	0	0.1	0.2	V	

**WRITE**

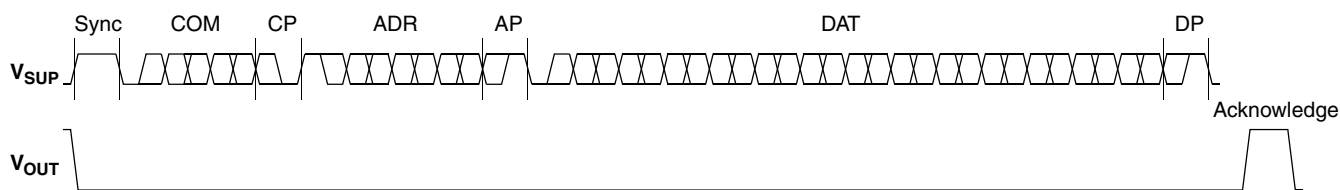

Fig. 6–2: Telegram for coding a Write command

**READ**

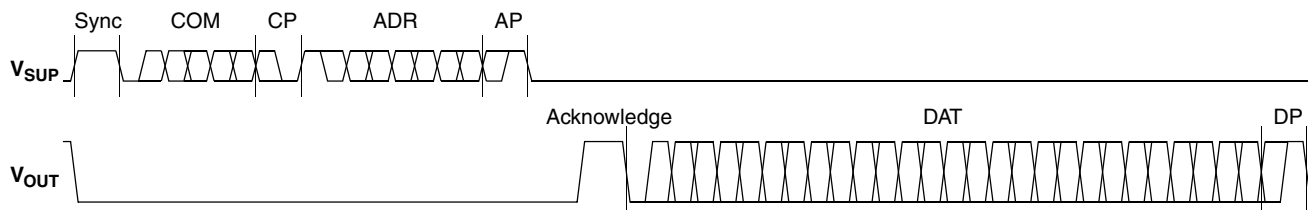

Fig. 6–3: Telegram for coding a Read command

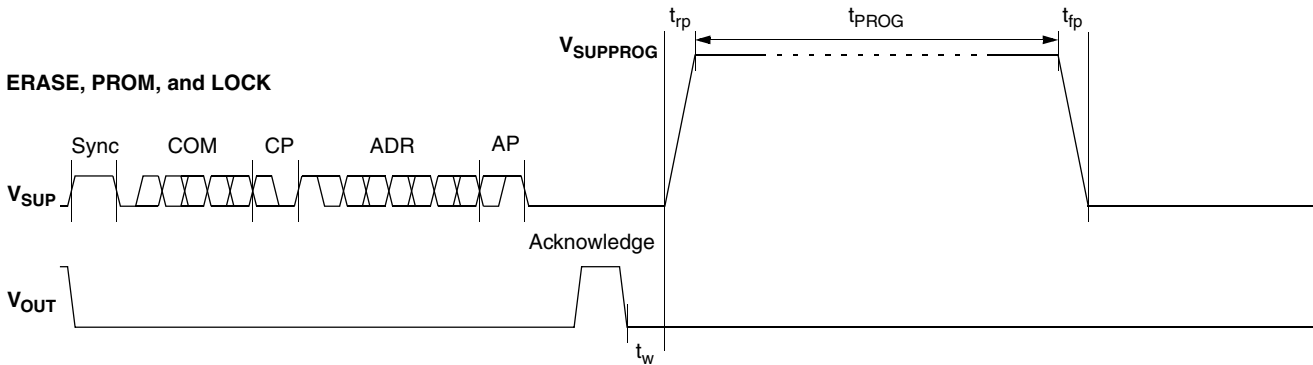

Fig. 6-4: Telegram for coding the EEPROM programming

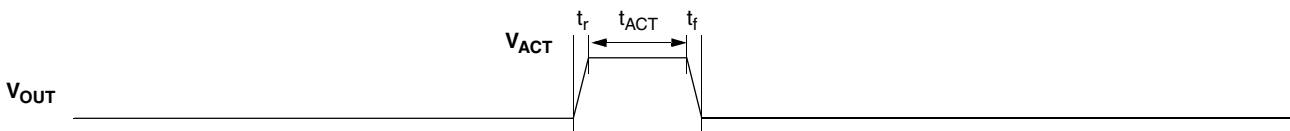

Fig. 6-5: Activate pulse

**6.3. Telegram Codes**

**Sync Bit**

Each telegram starts with the Sync Bit. This logical “0” pulse defines the exact timing for  $t_{p0}$ .

**Command Bits (COM)**

The Command code contains 3 bits and is a binary number. Table 6-2 shows the available commands and the corresponding codes for the HAL 1002.

**Command Parity Bit (CP)**

This parity bit is “1” if the number of zeros within the 3 Command Bits is uneven. The parity bit is “0”, if the number of zeros is even.

**Address Bits (ADR)**

The Address code contains 4 bits and is a binary number. Table 6-3 shows the available addresses for the HAL 1002 registers.

**Address Parity Bit (AP)**

This parity bit is “1” if the number of zeros within the 4 Address bits is uneven. The parity bit is “0” if the number of zeros is even.

**Data Bits (DAT)**

The 14 Data Bits contain the register information.

The registers use different number formats for the Data Bits. These formats are explained in Section 6.4.

In the Write command, the last bits are valid. If, for example, the TC register (10 bits) is written, only the last 10 bits are valid.

In the Read command, the first bits are valid. If, for example, the TC register (10 bits) is read, only the first 10 bits are valid.

**Data Parity Bit (DP)**

This parity bit is “1” if the number of zeros within the binary number is even. The parity bit is “0” if the number of zeros is uneven.

**Acknowledge**

After each telegram, the output answers with the Acknowledge signal. This logical “0” pulse defines the exact timing for  $t_{pOUT}$ .



**Table 6–2:** Available commands

Command	Code	Explanation
READ	2	read a register
WRITE	3	write a register
PROM	4	program all nonvolatile registers (except the lock bits)
ERASE	5	erase all nonvolatile registers (except the lock bits)

**6.4. Number Formats**

**Binary number:**

The most significant bit is given as first, the least significant bit as last digit.

Example: 101001 represents 41 decimal.

**Signed binary number:**

The first digit represents the sign of the following binary number (1 for negative, 0 for positive sign).

Example: 0101001 represents +41 decimal  
 1101001 represents –41 decimal

**Two’s-complement number:**

The first digit of positive numbers is “0”, the rest of the number is a binary number. Negative numbers start with “1”. In order to calculate the absolute value of the number, calculate the complement of the remaining digits and add “1”.

Example: 0101001 represents +41 decimal  
 1010111 represents –41 decimal

**6.5. Register Information**

**LOW Level**

- The register range is from 0 up to 255.
- The register value is calculated by:

$$\text{LOW Level} = \frac{\text{Low-Level Voltage} \times 2}{V_{SUP}} \times 255$$

**HIGH Level**

- The register range is from 0 up to 511.
- The register value is calculated by:

$$\text{HIGH Level} = \frac{\text{High-Level Voltage}}{V_{SUP}} \times 511$$

**VOQ**

- The register range is from –1024 up to 1023.
- The register value is calculated by:

$$\text{VOQ} = \frac{V_{OQ}}{V_{SUP}} \times 1024$$

**SENSITIVITY**

- The register range is from -8192 up to 8191.
- The register value is calculated by:

$$MODE = RANGE \times 512 + SIGNOC \times 256 + OUTPUTMODE \times 32 + FILTER \times 8 + RANGE \times 2 + OFFSETCORRECTION$$

$$SENSITIVITY = Sensitivity \times 2048$$

SIGNOC = Sign Offset Correction

**TC**

- The TC register range is from 0 up to 1023.
- The register value is calculated by:

$$TC = GROUP \times 256 + TCValue \times 8 + TCSQValue$$

**D/A-READOUT**

- This register is read only.
- The register range is from 0 up to 16383.

**MODE**

- The register range is from 0 up to 1023 and contains the settings for FILTER, RANGE, OUTPUTMODE and OFFSET CORRECTION:

**DEACTIVATE**

- This register can only be written.
- The register has to be written with 2063 decimal (80F hexadecimal) for the deactivation.
- The sensor can be reset with an Activate pulse on the output pin or by switching off and on the supply voltage.

**Table 6-3:** Available register addresses

Register	Code	Data Bits	Format	Customer	Remark
LOW LEVEL	1	8	binary	read/write/program	Low voltage
HIGH LEVEL	2	9	binary	read/write/program	High voltage
VOQ	3	11	two's compl. binary	read/write/program	Output quiescent voltage
SENSITIVITY	4	14	signed binary	read/write/program	
MODE	5	10	binary	read/write/program	Range, filter, output mode, Offset Correction settings
LOCKR	6	2	binary	read/write/program	Lock Bit
GP REGISTERS 1..3	8	3x13	binary	read/write/program	1)
D/A-READOUT	9	14	binary	read	Bit sequence is reversed during read
TC	11	10	binary	read/write/program	bits 0 to 2 TCSQ bits 3 to 7 TC bits 7 to 9 TC Range
GP REGISTER 0	12	13	binary	read/write/program	1)
DEACTIVATE	15	12	binary	write	Deactivate the sensor

1) To read/write this register it is mandatory to read/write all GP register one after the other starting with GP0. In case of a writing the registers it is necessary to first write all registers followed by one store sequence at the end. Even if only GP0 should be changed all other GP registers must first be read and the read out data must be written again to these registers.

Table 6–4: Data formats

Register	Char	DAT3				DAT2				DAT1				DAT0			
	Bit	15	14	13	12	11	10	09	08	07	06	05	04	03	02	01	00
LOW LEVEL	Write	–	–	–	–	–	–	–	–	V	V	V	V	V	V	V	V
	Read	–	–	V	V	V	V	V	V	V	V	–	–	–	–	–	–
HIGH LEVEL	Write	–	–	–	–	–	–	–	V	V	V	V	V	V	V	V	V
	Read	–	–	V	V	V	V	V	V	V	V	V	–	–	–	–	–
VOQ	Write	–	–	–	–	–	V	V	V	V	V	V	V	V	V	V	V
	Read	–	–	V	V	V	V	V	V	V	V	V	V	V	–	–	–
SENSITIVITY	Write	–	–	V	V	V	V	V	V	V	V	V	V	V	V	V	V
	Read	–	–	V	V	V	V	V	V	V	V	V	V	V	V	V	V
MODE	Write	–	–	–	–	–	–	V	V	V	V	V	V	V	V	V	V
	Read	–	–	V	V	V	V	V	V	V	V	V	V	–	–	–	–
LOCKR	Write	–	–	–	–	–	–	–	–	–	–	–	–	–	–	V	V
	Read	–	–	V	V	–	–	–	–	–	–	–	–	–	–	–	–
GP 1..3 Registers	Write	–	–	–	V	V	V	V	V	V	V	V	V	V	V	V	V
	Read	–	–	V	V	V	V	V	V	V	V	V	V	V	V	V	–
D/A-READOUT <sup>1)</sup>	Read	–	–	V	V	V	V	V	V	V	V	V	V	V	V	V	V
TC	Write	–	–	–	–	–	–	V	V	V	V	V	V	V	V	V	V
	Read	–	–	V	V	V	V	V	V	V	V	V	V	–	–	–	–
GP 0 Register	Write	–	–	–	V	V	V	V	V	V	V	V	V	V	V	V	V
	Read	–	–	V	V	V	V	V	V	V	V	V	V	V	V	V	–
DEACTIVATE	Write	–	–	–	–	1	0	0	0	0	0	0	0	1	1	1	1

V: valid, –: ignore, bit order: MSB first  
<sup>1)</sup> LSB first

---

## 6.6. Programming Information

If the content of any register (except the lock registers) is to be changed, the desired value must first be written into the corresponding RAM register. Before reading out the RAM register again, the register value must be permanently stored in the EEPROM.

Permanently storing a value in the EEPROM is done by first sending an ERASE command followed by sending a PROM command. **The address within the ERASE and PROM commands must be zero.** ERASE and PROM act on all registers in parallel.

If all HAL 1002 registers are to be changed, all writing commands can be sent one after the other, followed by sending one ERASE and PROM command at the end.

During all communication sequences, the customer has to check if the communication with the sensor was successful. This means that the acknowledge and the parity bits sent by the sensor have to be checked by the customer. If the Micronas programmer board is used, the customer has to check the error flags sent from the programmer board.

---

**Note:** For production and qualification tests it is mandatory to set the LOCK bit after final adjustment and programming of HAL 1002. The LOCK function is active after the next power-up of the sensor.

The success of the lock process shall be checked by reading at least one sensor register after locking and/or by an analog check of the sensors output signal.

Electrostatic discharges (ESD) may disturb the programming pulses. Please take precautions against ESD.

---

## 7. Data Sheet History

1. Preliminary Data Sheet "HAL 1002 Highly Precise Programmable Hall-Effect Switch", Dec. 13, 2013, PD000214\_001EN. First release of the preliminary data sheet.
2. Data Sheet "HAL 1002 Highly Precise Programmable Hall-Effect Switch", April 25, 2014, DSH000163\_001EN. First release of the data sheet.

### Major Changes:

- Block diagram updated
- Parameter values for Programming Resolution and Threshold Accuracy added

# Mouser Electronics

Authorized Distributor

Click to View Pricing, Inventory, Delivery & Lifecycle Information:

[TDK:](#)

[HAL1002UT-A](#)



Компания «ЭлектроПласт» предлагает заключение долгосрочных отношений при поставках импортных электронных компонентов на взаимовыгодных условиях!

Наши преимущества:

- Оперативные поставки широкого спектра электронных компонентов отечественного и импортного производства напрямую от производителей и с крупнейших мировых складов;
- Поставка более 17-ти миллионов наименований электронных компонентов;
- Поставка сложных, дефицитных, либо снятых с производства позиций;
- Оперативные сроки поставки под заказ (от 5 рабочих дней);
- Экспресс доставка в любую точку России;
- Техническая поддержка проекта, помощь в подборе аналогов, поставка прототипов;
- Система менеджмента качества сертифицирована по Международному стандарту ISO 9001;
- Лицензия ФСБ на осуществление работ с использованием сведений, составляющих государственную тайну;
- Поставка специализированных компонентов (Xilinx, Altera, Analog Devices, Intersil, Interpoint, Microsemi, Aeroflex, Peregrine, Syfer, Eurofarad, Texas Instrument, Miteq, Cobham, E2V, MA-COM, Hittite, Mini-Circuits, General Dynamics и др.);

Помимо этого, одним из направлений компании «ЭлектроПласт» является направление «Источники питания». Мы предлагаем Вам помощь Конструкторского отдела:

- Подбор оптимального решения, техническое обоснование при выборе компонента;
- Подбор аналогов;
- Консультации по применению компонента;
- Поставка образцов и прототипов;
- Техническая поддержка проекта;
- Защита от снятия компонента с производства.



#### Как с нами связаться

**Телефон:** 8 (812) 309 58 32 (многоканальный)

**Факс:** 8 (812) 320-02-42

**Электронная почта:** [org@eplast1.ru](mailto:org@eplast1.ru)

**Адрес:** 198099, г. Санкт-Петербург, ул. Калинина, дом 2, корпус 4, литера А.