

PLEASE CHECK WWW.MOLEX.COM FOR LATEST PART INFORMATION

Part Number: [5033044410](#)
Status: **Active**
Overview: [slimstack_mm016_pitch](#)
Description: 0.40mm (.016") Pitch SlimStack™ Board-to-Board Receptacle, SMT, Dual Row, Vertical, 0.70mm (.028") Stacking Height, 44 Circuits

Documents:

[3D Model](#) [Product Specification PS-503304-001 \(PDF\)](#)
[Drawing \(PDF\)](#) [RoHS Certificate of Compliance \(PDF\)](#)

General

Product Family	PCB Receptacles
Series	503304
Application	Board-to-Board
Overview	slimstack_mm016_pitch
Product Name	SlimStack™

Physical

Circuits (Loaded)	44
Color - Resin	Black
Durability (mating cycles max)	30
Glow-Wire Compliant	No
Lock to Mating Part	Yes
Mated Height (in)	0.028 In
Mated Height (mm)	0.70 mm
Material - Metal	Copper Alloy
Material - Plating Mating	Gold
Material - Plating Termination	Gold
Number of Rows	2
Orientation	Vertical
PCB Locator	No
PCB Retention	Yes
Packaging Type	Embossed Tape on Reel
Pitch - Mating Interface (in)	0.016 In
Pitch - Mating Interface (mm)	0.40 mm
Polarized to Mating Part	No
Polarized to PCB	No
Stackable	No
Temperature Range - Operating	-40°C to +85°C
Termination Interface: Style	Surface Mount

Electrical

Current - Maximum per Contact	0.3A
Voltage - Maximum	50V AC/DC

Material Info

Reference - Drawing Numbers

Application Specification	AS-503304-001
Packaging Specification	SPK-503304-001
Product Specification	PS-503304-001, RPS-503304-004, RPS-503304-005
Sales Drawing	SD-503304-001, SD-503304-002

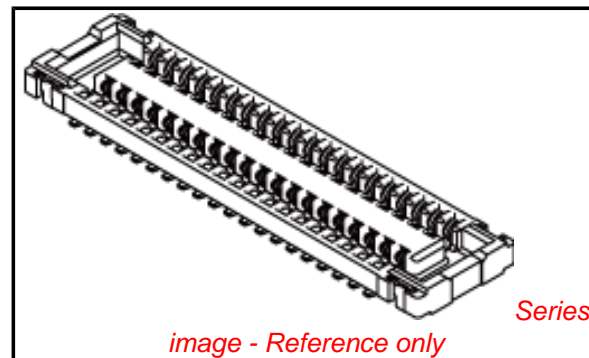

EU RoHS

**ELV and RoHS
Compliant**
**REACH SVHC
Contains SVHC: No**
**Halogen-Free
Status
Not Reviewed**

China RoHS



**Need more information on product
environmental compliance?**

Email productcompliance@molex.com
 For a multiple part number RoHS Certificate of Compliance, [click here](#)

Please visit the [Contact Us](#) section for any non-product compliance questions.

Search Parts in this Series

[503304Series](#)

Mates With

[503308 PCB Header](#)

注記 NOTES

1. 使用材料 MATERIAL

ハウジング : 液晶ポリマー (LCP) UL94V-0 (黒)
 HOUSING: LIQUID CRYSTAL POLYMER UL94V-0 (COLOR:BLACK)
 ターミナル : 銅合金
 TERMINAL : COPPER ALLOY

金具 : 銅合金
 FITTING NAIL : COPPER ALLOY

5. テール平坦度は、 0.08 以下

テール及び金具の平坦度は、 0.1 以下
 TAIL COPLANARITY TO BE 0.08 MAXIMUM.
 TAIL AND FITTING NAIL COPLANARITY TO BE 0.1 MAXIMUM.
 6. ELV and RoHS COMPLIANT.

2. メッキ仕様 PLATING

ターミナル TERMINAL

金メッキ
 GOLD
 下地メッキ : ニッケルメッキ
 UNDER PLATING : NICKEL

※コンタクト部とテール部はニッケルメッキによって分断されている金メッキです。
 DIVIDE INTO PARTS THE GOLD PLATING OF THE CONTACT AND THE TAIL PART BY THE NICKEL PLATING.

金具 FITTING NAIL

錫メッキ
 Tin PLATING
 下地メッキ : ニッケルメッキ
 UNDER PLATING : NICKEL

△ (全極数 / 2) = 偶数の場合に適用。
 APPLY FOR (CIRCUIT/2)=EVEN.

4. 嵌合相手 : 503308 シリーズ
 MATE WITH : 503308 SERIES.

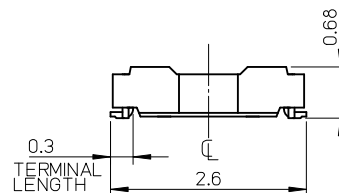
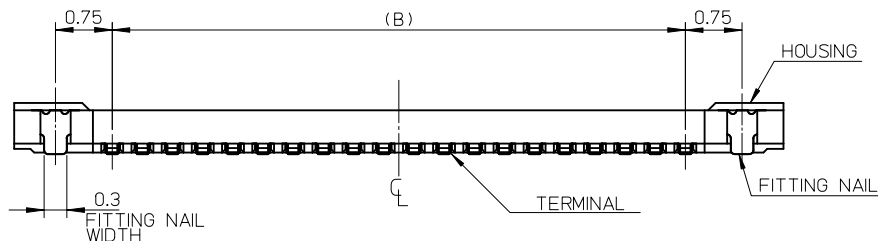
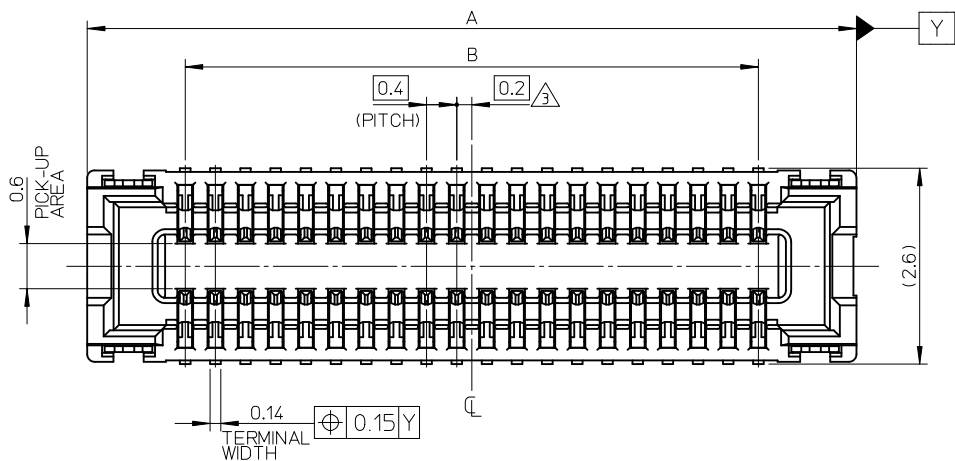

11.6	14.2	503304-6010	60
9.6	12.2	503304-5010	50
8.4	11.0	503304-4410	44
8.0	10.6	503304-4210	42
7.6	10.2	503304-4010	40
5.6	8.2	503304-3010	30
4.8	7.4	503304-2610	26
3.6	6.2	503304-2010	20
3.2	5.8	503304-1810	18
2.8	5.4	503304-1610	16
2.0	4.6	503304-1210	12
B	A	EMBOSSED PACKAGE	
		極数	CIRCUITS
		オーダー番号 ORDER No.	
CONNECTOR SERIES No. : 503304-**09			

REVISED EC NO: J2010-4761 DRWN: M. AKAHASHI 03/2009/12/23 CHKD: THIRATA 20/10/03/17 APPR: MSASAO 20/10/03/18	DESCRIPTION REV	GENERAL TOLERANCES (UNLESS SPECIFIED)		DIMENSION STYLE MM ONLY		SCALE 15:1	DESIGN UNITS METRIC	THIRD ANGLE PROJECTION	
		10 UNDER	± 0.2	DRAWN BY KSASAKI	DATE 2008/04/17	TITLE 0.4 B-TO-B CONN. HGT=0.7 W=2.6 REC. ASS'Y			
		10 OVER 30 UNDER	± 0.25	CHECKED BY THIRATA	DATE 2008/04/17	MOLEX INCORPORATED			
		30 OVER	± 0.3	APPROVED BY M. SASAO	DATE 2008/04/17	DOCUMENT NO. SD-503304-001			
ANGULAR ± 1 °		DRAFT WHERE APPLICABLE MUST REMAIN WITHIN DIMENSIONS		MATERIAL NO. SEE CHART		SHEET NO. 1 OF 2		THIS DRAWING CONTAINS INFORMATION THAT IS PROPRIETARY TO MOLEX INCORPORATED AND SHOULD NOT BE USED WITHOUT WRITTEN PERMISSION	

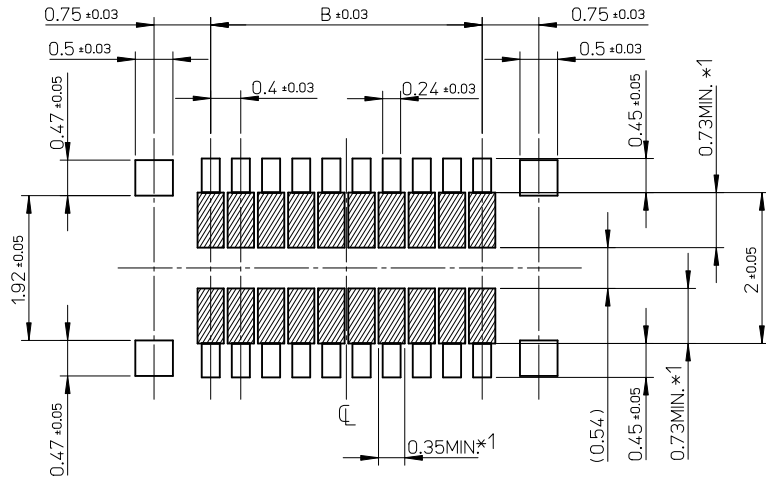

RECOMMENDED P.W. BOARD
PATTERN LAYOUT

*1 パターン引き回し、および半田禁止エリア
(当該箇所においては、これと接する回路以外の配線を禁止する。
また、接する回路を配線する場合はレジストを施し、この部分に
半田は無きこととする。)
*1 PROHIBITED AREA OF PATTERN WIRING AND SOLDER.
(FOR EACH AREA, THE WIRING THAT TOUCHES ON THE SOLDER
CAN BE ATTACHED, THEN COVERED WITH A FILM TO KEEP SOLDER OUT.)

REVISED EC NO: J2010-1761 G DRWN:MTAKAHASHI 03/2009/12/23 CHKD:THIRATA 2010/03/17 APPR:MSASAO 2010/03/18	GENERAL TOLERANCES (UNLESS SPECIFIED)		DIMENSION STYLE MM ONLY	SCALE 15:1	DESIGN UNITS METRIC	THIRD ANGLE PROJECTION
	10 UNDER	± 0.2	DRAWN BY KSASAKI	DATE 2008/04/17	TITLE 0.4 B-TO-B CONN. HGT=0.7 W=2.6 REC. ASS'Y	
	10 OVER 30 UNDER	± 0.25	CHECKED BY THIRATA	DATE 2008/04/17		
	30 OVER	± 0.3	APPROVED BY M. SASAO	DATE 2008/04/17	MOLEX INCORPORATED DOCUMENT NO. SD-503304-001 SHEET NO. 2 OF 2	
ANGULAR ±1 °		MATERIAL NO. SEE CHART				
DRAFT WHERE APPLICABLE MUST REMAIN WITHIN DIMENSIONS		THIS DRAWING CONTAINS INFORMATION THAT IS PROPRIETARY TO MOLEX INCORPORATED AND SHOULD NOT BE USED WITHOUT WRITTEN PERMISSION				

注記 NOTES

- 製品詳細寸法については製品単体図面を参照下さい。
RE DETAILED DIMENSION, SEE PRODUCT DRAWING.
- 梱包数量: 3000 個/リール
NUMBER OF CONNECTORS: 3000PCS/REEL
- リードテープ長さ LEAD TAPE LENGTH

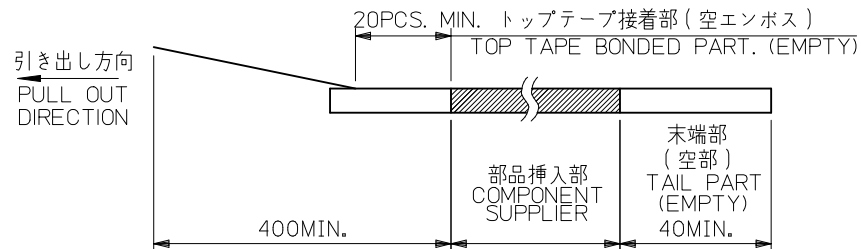
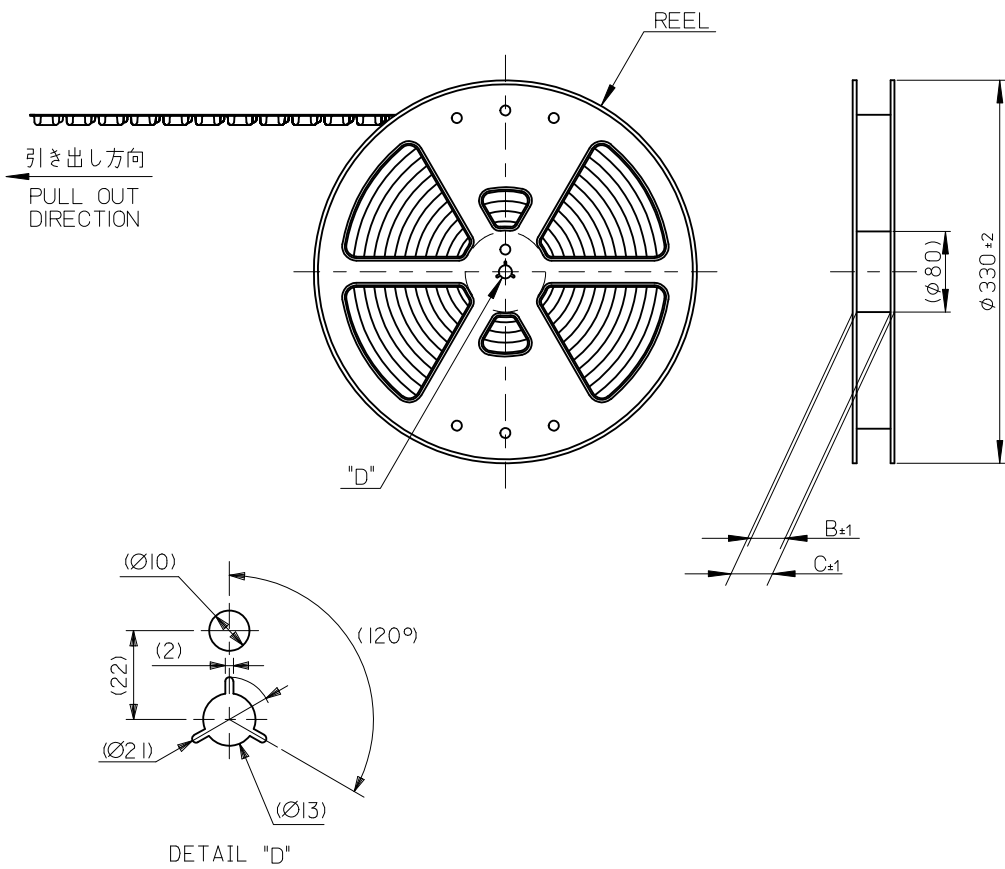

- トップテープの剥離強度: 0.1N~1.3N(10gf~130gf)
(剥離方向は下図参照)
尚、本規格値は出荷時に適用。(但し、輸送時に剥離が発生しないこと。)
PEELING OFF FORCE OF TOP TAPE: 0.1N~1.3N(10gf~130gf)
(PEELING DIRECTION AS SHOWN IN FOLLOWING FIG.)
THIS REQUIREMENT SHOULD BE APPLIED AT SHIPMENT.
PEEL OFF SHOULD NOT BE ALLOWED, DURING TRANSPORTION.

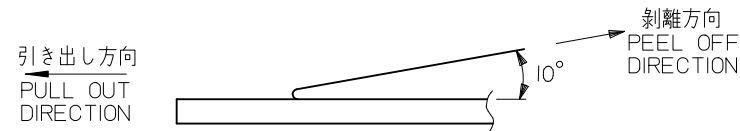

- 材料 MATERIAL
キャリアテープ (CARRIER TAPE): ポリスチレン (POLYSTYRENE)
トップテープ (TOP TAPE): PET, OTHER
リール (REEL): ポリスチレン (PS) <リサイクル材を含む>
POLYSTYRENE (PS) <RECYCLE MATERIAL CONTAINED>
- ELV 及び RoHS適合品
ELV AND RoHS COMPLIANT

MODEL NO. 503304-***10

REVISED EC NO: J2010-1761 DRWN: TAKAHASHI 2010/01/08 CHKD: THIRATA 2010/03/17 APPR: MSASAO 2010/03/18	GENERAL TOLERANCES (UNLESS SPECIFIED)		DIMENSION STYLE MM ONLY		SCALE 1:1	DESIGN UNITS METRIC	THIRD ANGLE PROJECTION
	10 UNDER	±0.2	DRAWN BY KSASAKI	DATE 2008/12/12	TITLE 0.4 B-TO-B CONN. HGT=0.7 REC ASSY EMBSTP PKG		
	10 OVER 30 UNDER	±0.25	CHECKED BY THIRATA	DATE 2008/12/12	MOLEX INCORPORATED		
	30 OVER	±0.3	APPROVED BY MSASAO	DATE 2008/12/12	DOCUMENT NO. SD-503304-002		
DESCRIPTION	ANGULAR ±1 °	DRAFT WHERE APPLICABLE MUST REMAIN WITHIN DIMENSIONS		MATERIAL NO. SEE CHART		SHEET NO. 1 OF 3	

引き出し方向
PULL OUT DIRECTION

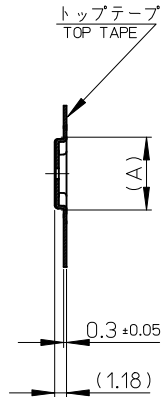

SECTION Y-Y

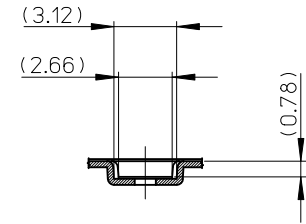
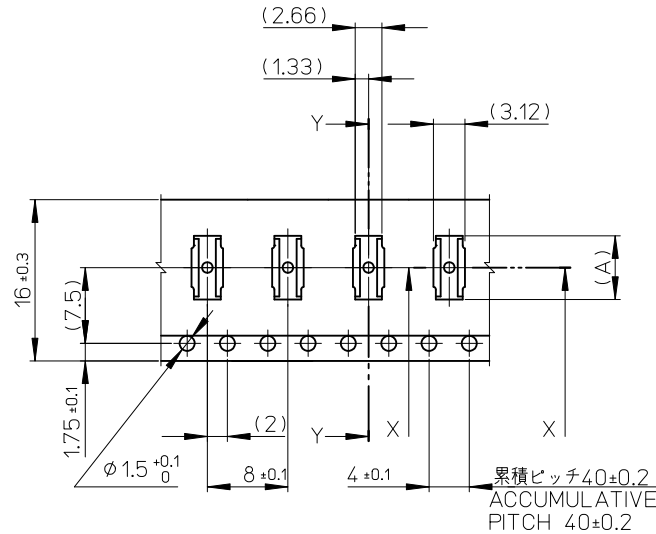

SECTION X-X

16mm 幅キャリアテープ
16mm WIDTH CARRIER TAPE

16	21.4	17.4	7.52	503304-2610	26
			7.12	503304-2410	24
			6.32	503304-2010	20
			5.92	503304-1810	18
			5.52	503304-1610	16
			4.72	503304-1210	12
キャリアテープ幅 CARRIER TAPE WIDTH			C	B	(A)
			MATERIAL No.		CKT.
			MODEL No.		503304-**10

REVISED EC NO: J2010-1761 DRWN: TAKAHASHI 2010/01/08 CHKD: THIRATA 2010/03/17 APPR: MSASAO 2010/03/18	DESCRIPTION GENERAL TOLERANCES (UNLESS SPECIFIED)	10 UNDER	± 0.2	DIMENSION STYLE	MM ONLY	SCALE	DESIGN UNITS	METRIC	THIRD ANGLE PROJECTION	
		10 OVER 30 UNDER	± 0.25	DRAWN BY	DATE	TITLE	0.4 B-TO-B CONN. HGT=0.7 REC ASSY EMBSTP PKG			
		30 OVER	± 0.3	CHECKED BY	DATE	APPROVED BY	DATE	MOLEX INCORPORATED		
		ANGULAR ± 1 °		DRAFT WHERE APPLICABLE MUST REMAIN WITHIN DIMENSIONS		MATERIAL NO.	SEE CHART	DOCUMENT NO.	SD-503304-002	
				SIZE	A3	THIS DRAWING CONTAINS INFORMATION THAT IS PROPRIETARY TO MOLEX INCORPORATED AND SHOULD NOT BE USED WITHOUT WRITTEN PERMISSION				

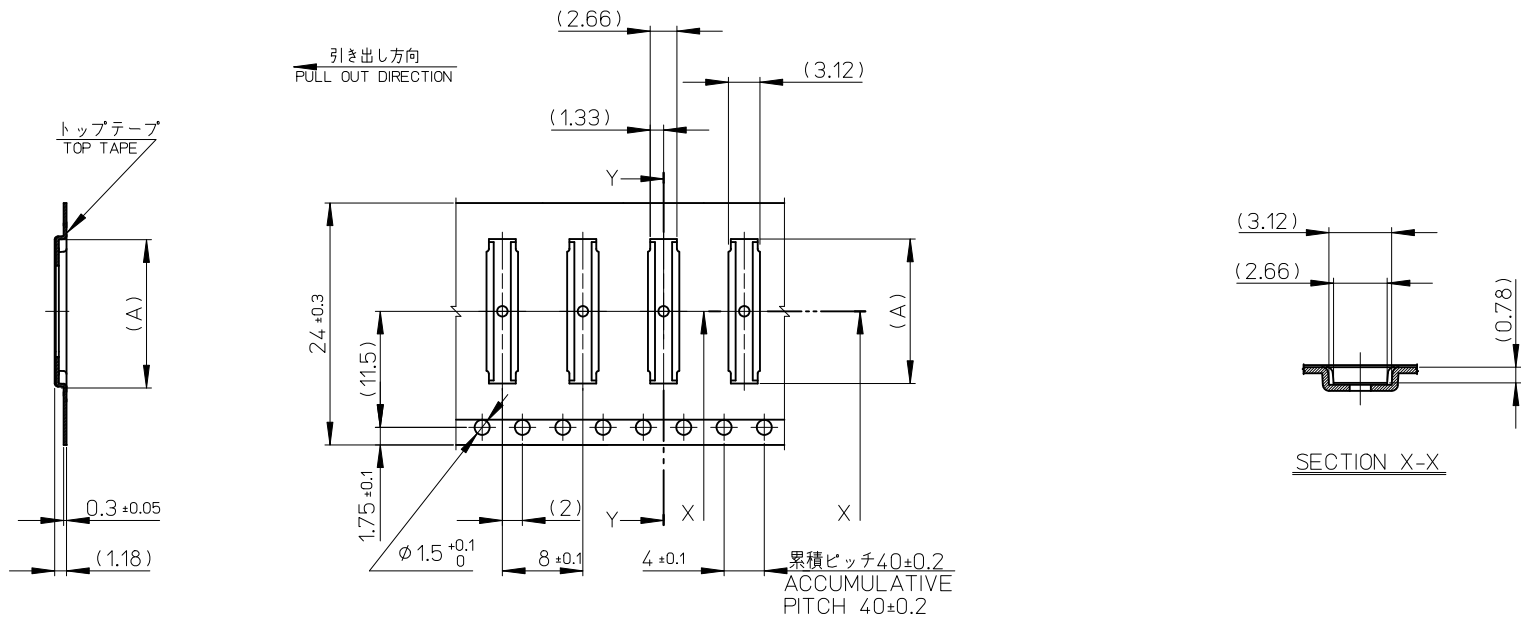

SECTION Y-Y

SECTION X-X

24mm 幅キャリアテープ
24mm WIDTH CARRIER TAPE

24	29.4	25.4	14.32	503304-6010	60
			12.32	503304-5010	50
			11.12	503304-4410	44
			10.72	503304-4210	42
			10.32	503304-4010	40
			8.32	503304-3010	30
キャリアテープ幅 CARRIER TAPE WIDTH			C	B	(A)
			MATERIAL No.		CKT.
			MODEL No.		503304-**10

REVISED EC NO: J2010-1761 DRWN: TAKAHASHI 2010/01/08 CHKD: THIRATA 2010/03/17 APPR: MSASAO 2010/03/18	DESCRIPTION	GENERAL TOLERANCES (UNLESS SPECIFIED)		DIMENSION STYLE MM ONLY		SCALE	DESIGN UNITS	THIRD ANGLE PROJECTION	
		10 UNDER	±0.2	DRAWN BY	DATE	TITLE	0.4 B-TO-B CONN. HGT=0.7 REC ASSY EMBSTP PKG		
		10 OVER 30 UNDER	±0.25	CHECKED BY	DATE				
		30 OVER	±0.3	APPROVED BY	DATE	MOLEX INCORPORATED			
		ANGULAR	±1 °	MATERIAL NO.	DOCUMENT NO.	SHEET NO.			
DRAFT WHERE APPLICABLE MUST REMAIN WITHIN DIMENSIONS		SIZE	THIS DRAWING CONTAINS INFORMATION THAT IS PROPRIETARY TO MOLEX INCORPORATED AND SHOULD NOT BE USED WITHOUT WRITTEN PERMISSION						



Компания «ЭлектроПласт» предлагает заключение долгосрочных отношений при поставках импортных электронных компонентов на взаимовыгодных условиях!

Наши преимущества:

- Оперативные поставки широкого спектра электронных компонентов отечественного и импортного производства напрямую от производителей и с крупнейших мировых складов;
- Поставка более 17-ти миллионов наименований электронных компонентов;
- Поставка сложных, дефицитных, либо снятых с производства позиций;
- Оперативные сроки поставки под заказ (от 5 рабочих дней);
- Экспресс доставка в любую точку России;
- Техническая поддержка проекта, помощь в подборе аналогов, поставка прототипов;
- Система менеджмента качества сертифицирована по Международному стандарту ISO 9001;
- Лицензия ФСБ на осуществление работ с использованием сведений, составляющих государственную тайну;
- Поставка специализированных компонентов (Xilinx, Altera, Analog Devices, Intersil, Interpoint, Microsemi, Aeroflex, Peregrine, Syfer, Eurofarad, Texas Instrument, Miteq, Cobham, E2V, MA-COM, Hittite, Mini-Circuits, General Dynamics и др.);

Помимо этого, одним из направлений компании «ЭлектроПласт» является направление «Источники питания». Мы предлагаем Вам помощь Конструкторского отдела:

- Подбор оптимального решения, техническое обоснование при выборе компонента;
- Подбор аналогов;
- Консультации по применению компонента;
- Поставка образцов и прототипов;
- Техническая поддержка проекта;
- Защита от снятия компонента с производства.



Как с нами связаться

Телефон: 8 (812) 309 58 32 (многоканальный)

Факс: 8 (812) 320-02-42

Электронная почта: org@eplast1.ru

Адрес: 198099, г. Санкт-Петербург, ул. Калинина, дом 2, корпус 4, литера А.