

# NHD-5.0-800480TF-ATXL#-CTP

## TFT (Thin-Film-Transistor) Color Liquid Crystal Display Module

NHD-	Newhaven Display
5.0-	5.0" Diagonal
800480-	800xRGBx480 Pixels
TF-	Model
A-	Built-in Driver / No Controller
T-	White LED Backlight
X-	TFT
L-	12:00 Optimum View, Enhanced Optical Characteristics, Wide Temperature
#	<b>RoHS Compliant</b>
CTP	Capacitive Touch Panel with Controller

### Newhaven Display International, Inc.

2661 Galvin Ct.

Elgin IL, 60124

Ph: 847-844-8795

Fax: 847-844-8796

[www.newhavendisplay.com](http://www.newhavendisplay.com)

[nhtech@newhavendisplay.com](mailto:nhtech@newhavendisplay.com)

[nhsales@newhavendisplay.com](mailto:nhsales@newhavendisplay.com)

## Document Revision History

Revision	Date	Description	Changed by
0	3/20/2013	Initial Release	AK
1	8/28/2013	Electrical Characteristics updated	AK
2	9/16/2014	Electrical Characteristics updated	ML
3	4/1/2015	CTP mechanical dimensions updated	AK

## Functions and Features

- 800xRGBx480 resolution, up to 16.7M colors
- 18-LED backlight
- 24 bit RGB interface
- Enhanced Optical Characteristics
- Capacitive Touch Panel with controller

# Mechanical Drawing

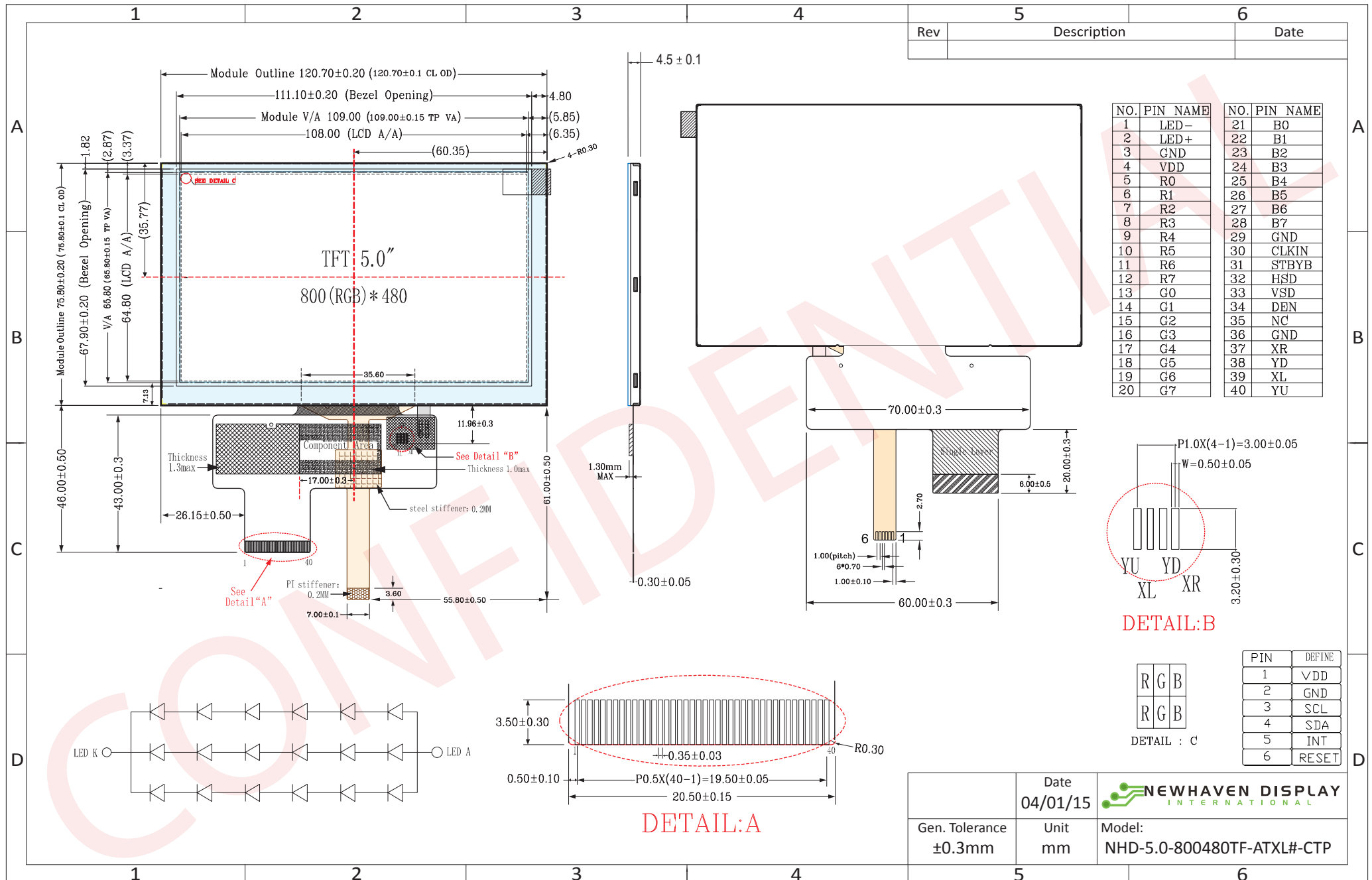

The drawing contained herein is the exclusive property of Newhaven Display International, Inc. and shall not be copied, reproduced, and/or disclosed in any format without permission.

## Pin Description

### TFT:

Pin No.	Symbol	External Connection	Function Description
1	LED-	LED Power Supply	Ground for Backlight
2	LED+	LED Power Supply	Backlight Power Supply (60mA @ ~19.2V)
3	GND	Power Supply	Ground
4	VDD	Power Supply	Power supply for LCD and logic (3.3V)
5-12	[R0-R7]	MPU	Red Data Signals
13-20	[G0-G7]	MPU	Green Data Signals
21-28	[B0-B7]	MPU	Blue Data Signals
29	GND	Power Supply	Ground
30	CLKIN	MPU	Clock for input data (Rising Edge)
31	STBYB	MPU	1: Normal Operation; 0: Standby Mode
32	HSD	MPU	Line synchronization signal
33	VSD	MPU	Frame synchronization signal
34	DEN	MPU	Data Enable signal
35	NC	-	No Connect
36	GND	Power Supply	Ground
37	XR	-	No Connect
38	YD	-	No Connect
39	XL	-	No Connect
40	YU	-	No Connect

**Recommended LCD connector:** 0.5mm pitch 40-Conductor FFC. Molex p/n: 54104-4031 (top contact)

**Backlight connector:** on LCD connector

**Mates with:** ---

### Capacitive Touch Panel:

Pin No.	Symbol	External Connection	Function Description
1	VCC	Power Supply	Power supply for logic (3.0V)
2	GND	Power Supply	Ground
3	SCL	MPU	Serial I2C Clock (Requires pull-up resistor)
4	SDA	MPU	Serial I2C Data (Requires pull-up resistor)
5	/INT	MPU	Interrupt signal from touch panel module to host
6	/WAKE	MPU	External interrupt signal from host (0: Disable /INT 1: Enable /INT)

**Recommended connector:** 1.0mm pitch 6-Conductor FFC. Molex p/n: 52271-0679

## Driver/Controller Information

### TFT:

Built-in HX8264-D02 Source Driver: [http://www.newhavendisplay.com/app\\_notes/HX8264-D02.pdf](http://www.newhavendisplay.com/app_notes/HX8264-D02.pdf)

Built in HX8664-B Gate Driver: [http://www.newhavendisplay.com/app\\_notes/HX8664-B.pdf](http://www.newhavendisplay.com/app_notes/HX8664-B.pdf)

### Capacitive Touch Panel:

Built-in FocalTech FT5x06 controller.

Please download specification at [http://www.newhavendisplay.com/app\\_notes/FT5x06.pdf](http://www.newhavendisplay.com/app_notes/FT5x06.pdf)

## Electrical Characteristics

### TFT:

Item	Symbol	Condition	Min.	Typ.	Max.	Unit
Operating Temperature Range	Top	Absolute Max	-20	-	+70	°C
Storage Temperature Range	Tst	Absolute Max	-30	-	+80	°C
Supply Voltage	VDD		3.0	3.3	3.6	V
Supply Current	IDD	VDD=3.3	-	77	-	mA
"H" Level input	Vih		0.7*VDD	-	VDD	V
"L" Level input	Vil		0	-	0.3*VDD	V
"H" Level output	Voh		VDD-0.4	-	-	V
"L" Level output	Vol		-	-	GND+0.4	V
Backlight Supply Voltage	VLED		16.2	19.2	20.4	V
Backlight Supply Current	ILED		45	60	75	mA

### Capacitive Touch Panel:

Item	Symbol	Condition	Min.	Typ.	Max.	Unit
Operating Temperature Range	Top	Absolute Max	-20	-	+70	°C
Storage Temperature Range	Tst	Absolute Max	-30	-	+80	°C
Supply Voltage	VDD		2.8	-	3.3	V
Supply Current – Operating	IDD	Ta=25°C, VDD=2.8V	-	6.0	-	mA
Supply Current – Hibernate	IDD	Ta=25°C, VDD=2.8V	-	1.0	-	uA
"H" Level input	Vih		0.7*VDD	-	VDD	V
"L" Level input	Vil		VSS	-	0.3*VDD	V
"H" Level output	Voh		0.7*VDD	-	VDD	V
"L" Level output	Vol		VSS	-	0.3*VDD	V

### Optical Characteristics:

Item	Symbol	Condition	Min.	Typ.	Max.	Unit
Viewing Angle – Top		Cr ≥10	60	75	-	°
Viewing Angle – Bottom			50	65	-	°
Viewing Angle – Left			60	75	-	°
Viewing Angle – Right			60	75	-	°
Contrast Ratio	Cr		500	600	-	
Luminance	YL		400	450	-	cd/m <sup>2</sup>
Response Time	Tr+Tf	-	-	20	30	ms

### Capacitive Touch Panel Material Characteristics:

Property	Requirement	Unit
IC	FT5306DE4	
ITO Glass thickness	0.55	mm
Surface Hardness	≥6	H
Light transmission	83% ± 5%	-
Operating Humidity	20~90	RH
Storage Humidity	20~90	RH

# Capacitive Touch Panel Registers

Address	Name	B7	B6	B5	B4	B3	B2	B1	B0	Access	
00h	DEVICE_MODE	Device Mode [2..0]									R/W
01h	GEST_ID	Gesture ID [7..0]									R
02h	TD_STATUS							Touch Points [3..0]			R
03h	TOUCH1_XH	Event Flag			1st Touch X Position MSB [11..8]					R	
04h	TOUCH1_XL	1st Touch X Position LSB [7..0]									R
05h	TOUCH1_YH	Touch ID [3..0]			1st Touch Y Position MSB [11..8]					R	
06h	TOUCH1_YL	1st Touch Y Position LSB [7..0]									R
07h										R	
08h										R	
09h	TOUCH2_XH	Event Flag			2nd Touch X Position MSB [11..8]					R	
0Ah	TOUCH2_XL	2nd Touch X Position LSB [7..0]									R
0Bh	TOUCH2_YH	Touch ID [3..0]			2nd Touch Y Position MSB [11..8]					R	
0Ch	TOUCH2_YL	2nd Touch Y Position LSB [7..0]									R
0Dh										R	
0Eh										R	
0Fh	TOUCH3_XH	Event Flag			3rd Touch X Position MSB [11..8]					R	
10h	TOUCH3_XL	3rd Touch X Position LSB [7..0]									R
11h	TOUCH3_YH	Touch ID [3..0]			3rd Touch Y Position MSB [11..8]					R	
12h	TOUCH3_YL	3rd Touch Y Position LSB [7..0]									R
13h										R	
14h										R	
15h	TOUCH4_XH	Event Flag			4th Touch X Position MSB [11..8]					R	
16h	TOUCH4_XL	4th Touch X Position LSB [7..0]									R
17h	TOUCH4_YH	Touch ID [3..0]			4th Touch Y Position MSB [11..8]					R	
18h	TOUCH4_YL	4th Touch Y Position LSB [7..0]									R
19h										R	
1Ah										R	
1Bh	TOUCH5_XH	Event Flag			5th Touch X Position MSB [11..8]					R	
1Ch	TOUCH5_XL	5th Touch X Position LSB [7..0]									R
1Dh	TOUCH5_YH	Touch ID [3..0]			5th Touch Y Position MSB [11..8]					R	
1Eh	TOUCH5_YL	5th Touch Y Position LSB [7..0]									R
1Fh										R	

Address	Name	B7	B6	B5	B4	B3	B2	B1	B0	Access
80h	ID_G_THGROUP	valid touching detect threshold								R/W
81h	ID_G_THPEAK	valid touching peak detect threshold								R/W
82h	ID_G_THCAL	the threshold when calculating the focus of touching								R/W
83h	ID_G_THWATER	the threshold when there is surface water								R/W
84h	ID_G_TEMP	the threshold of temperature compensation								R/W
85h	ID_G_THDIFF	the threshold whether the coordinate is different from original								R/W
86h	ID_G_CTRL							Power Control Mode [1..0]		R/W
87h	ID_G_TIME_ENTER_MONITOR	the timer for entering monitor status								R/W
88h	ID_G_PERIODACTIVE							Period Active [3..0]		R/W
89h	ID_G_PERIODMONITOR	the timer of entering idle when in monitor status								R/W
A0h	ID_G_AUTO_CLB_MODE	auto calibration mode								R/W
A1h	ID_G_LIB_VERSION_H	Firmware Library Version H byte								R
A2h	ID_G_LIB_VERSION_L	Firmware Library Version L byte								R
A3h	ID_G_CIPHER	Chip vendor ID								R
A4h	ID_G_MODE	the interrupt status to host								R
A5h	ID_G_PMODE	Power Consume Mode								
A6h	ID_G_FIRMID	Firmware ID								R
A7h	ID_G_STATE	Running State								
A8h	ID_G_FT5201ID	CTPM Vendor ID								R
A9h	ID_G_ERR	Error Code								R
AAh	ID_G_CLB	Configure TP module during calibration in Test Mode								R/W
FEh	LOG_MSG_CNT	The log MSG count								R
FFh	LOG_CUR_CHA	Current character of log message								R

NOTE: Registers 80h – AFh have been configured for optimum settings and do not need to be modified.

Register No	Register Name	Bits	Value	Description
00h	Device Mode	[2:0]	000b	Normal Operating Mode
			100b	Test Mode - read raw data (reserved)
			001b	System Information Mode (reserved)
01h	Gesture ID	[7:0]	48h	Zoom In
			49h	Zoom Out
			00h	No Gesture
02h	Touch Points	[3:0]	000b	0 touch points detected
			001b	1 touch point detected
			010b	2 touch points detected
			011b	3 touch points detected
			100b	4 touch points detected
			101b	5 touch points detected
03h	Touch 1 Event Flag	[7:6]	00b	Put Down
			01b	Put Up
			10b	Contact
			11b	Reserved
03h	TOUCH1_XH	[3:0]	0h - 1h	Upper 4 bits of X touch coordinate
04h	TOUCH1_XL	[7:0]	00h - FFh	Lower 8 bits of X touch coordinate
05h	TOUCH1_YH	[3:0]	0h - 1h	Upper 4 bits of Y touch coordinate
06h	TOUCH1_YL	[7:0]	00h - FFh	Lower 8 bits of Y touch coordinate
09h	Touch 2 Event Flag	[7:6]	00b	Put Down
			01b	Put Up
			10b	Contact
			11b	Reserved
09h	TOUCH2_XH	[3:0]	0h - 1h	Upper 4 bits of X touch coordinate
0Ah	TOUCH2_XL	[7:0]	00h - FFh	Lower 8 bits of X touch coordinate
0Bh	TOUCH2_YH	[3:0]	0h - 1h	Upper 4 bits of Y touch coordinate
0Ch	TOUCH2_YL	[7:0]	00h - FFh	Lower 8 bits of Y touch coordinate
0Fh	Touch 3 Event Flag	[7:6]	00b	Put Down
			01b	Put Up
			10b	Contact
			11b	Reserved
0Fh	TOUCH3_XH	[3:0]	0h - 1h	Upper 4 bits of X touch coordinate
10h	TOUCH3_XL	[7:0]	00h - FFh	Lower 8 bits of X touch coordinate
11h	TOUCH3_YH	[3:0]	0h - 1h	Upper 4 bits of Y touch coordinate
12h	TOUCH3_YL	[7:0]	00h - FFh	Lower 8 bits of Y touch coordinate
15h	Touch 4 Event Flag	[7:6]	00b	Put Down
			01b	Put Up
			10b	Contact
			11b	Reserved
15h	TOUCH4_XH	[3:0]	0h - 1h	Upper 4 bits of X touch coordinate
16h	TOUCH4_XL	[7:0]	00h - FFh	Lower 8 bits of X touch coordinate
17h	TOUCH4_YH	[3:0]	0h - 1h	Upper 4 bits of Y touch coordinate
18h	TOUCH4_YL	[7:0]	00h - FFh	Lower 8 bits of Y touch coordinate



Register No	Register Name	Bits	Value	Description
1Bh	Touch 5 Event Flag	[7:6]	00b 01b 10b 11b	Put Down Put Up Contact Reserved
1Bh	TOUCH5_XH	[3:0]	0h - 1h	Upper 4 bits of X touch coordinate
1Ch	TOUCH5_XL	[7:0]	00h - FFh	Lower 8 bits of X touch coordinate
1Dh	TOUCH5_YH	[3:0]	0h - 1h	Upper 4 bits of Y touch coordinate
1Eh	TOUCH5_YL	[7:0]	00h - FFh	Lower 8 bits of Y touch coordinate
80h	ID_G_THGROUP	[7:0]	00h - FFh	Valid touching detect threshold Actual value will be 4 times register's value Recommended: 46h
81h	ID_G_THPEAK	[7:0]	00h - FFh	valid touching peak detect threshold Recommended: 3Ch
82h	ID_G_THCAL	[7:0]	00h - FFh	Touch focus threshold Recommended: 1Dh
83h	ID_G_THWATER	[7:0]	00h - FFh	threshold when there is surface water Recommended: D3h
84h	ID_G_THTEMP	[7:0]	00h - FFh	threshold of temperature compensation Recommended: EBh
85h	ID_G_THDIFF	[7:0]	00h - FFh	Touch difference threshold Actual value is 32 times the register's value Recommended: A0h
86h	ID_G_CTRL	[1:0]	00h 01h	Power Control Mode: Not Auto Jump Power Control Mode: Auto Jump
87h	ID_G_TIME_ENTER_MONITOR	[7:0]	00h-FFh	Delay to enter 'Monitor' status (s) Recommended: C8h
88h	ID_G_PERIODACTIVE	[3:0]	3h-Eh	Period of 'Active' status (ms) Recommended: 6h
89h	ID_G_PERIODMONITOR	[7:0]	1Eh-FFh	Timer to enter 'idle' when in 'Monitor' (ms) Recommended: 28h
A0h	ID_G_AUTO_CLB_MODE	[7:0]	00h FFh	Auto calibration mode: Enable auto calibration Auto calibration mode: Disable auto calibration
A1h	ID_G_LIB_VERSION_H	[7:0]	30h	Firmware Library Version H byte
A2h	ID_G_LIB_VERSION_L	[7:0]	01h	Firmware Library Version L byte
A3h	ID_G_CIPHER	[7:0]	06h	Chip vendor ID
A4h	ID_G_MODE	[0:0]	00h 01h	Interrupt status: Enable interrupt to host Interrupt status: Disable interrupt to host
A5h	ID_G_PMODE	[1:0]	00h 01h 03h	'Active' Mode 'Monitor' Mode 'Hibernate' Mode
A6h	ID_G_FIRMID	[7:0]	30h	Firmware ID
A7h	ID_G_STATE	[7:0]	00h 01h 02h 03h 04h	Running State: Configure Running State: Work Running State: Calibration Running State: Factory Running State: Auto-calibration
A8h	ID_G_FT5201ID	[7:0]	98h	CTPM Vendor's Chip ID
A9h	ID_G_ERR	[7:0]	00h 03h 05h 1Ah	Error Code: OK Error Code: Chip register writing inconsistent with reading Error Code: Chip start fail Error Code: Calibration match fail

## Timing Characteristics – TFT Display

Parameter	Symbol	Spec.			Unit
		Min.	Typ.	Max.	
HS setup time	$T_{hst}$	8	-	-	ns
HS hold time	$T_{hhd}$	8	-	-	ns
VS setup time	$T_{vst}$	8	-	-	ns
VS hold time	$T_{vhd}$	8	-	-	ns
Data setup time	$T_{dsu}$	8	-	-	ns
Data hold time	$T_{dhd}$	8	-	-	ns
DE setup time	$T_{esu}$	8	-	-	ns
DE hold time	$T_{ehd}$	8	-	-	ns
VDD Power On Slew rate	$T_{POR}$	-	-	20	ms
RSTB pulse width	$T_{Rst}$	10	-	-	us
CLKIN cycle time	$T_{cph}$	20	-	-	ns
CLKIN pulse duty	$T_{cwh}$	40	50	60	%
Output stable time	$T_{sst}$	-	-	6	us

### Horizontal Timing

Parameter	Symbol	Spec.			Unit
		Min.	Typ.	Max.	
Horizontal Display Area	thd	800			DCLK
DCLK frequency	fclk	-	30	50	MHz
One Horizontal Line	th	889	928	1143	DCLK
HS pulse width	thpw	1	48	255	DCLK
HS Back Porch (Blanking)	thb	88			DCLK
HS Front Porch	thfp	1	40	255	DCLK
DE mode Blanking	th-thd	85	128	512	DCLK

### Vertical Timing

Parameter	Symbol	Spec.			Unit
		Min.	Typ.	Max.	
Vertical Display Area	tvd	480			$T_H$
VS period time	tv	513	525	767	$T_H$
VS pulse width	tvpw	3	3	255	$T_H$
VS Back Porch (Blanking)	tvb	32			$T_H$
VS Front Porch	tvfp	1	13	255	$T_H$
DE mode Blanking	tv-tvd	4	45	255	$T_H$

## Horizontal Timing

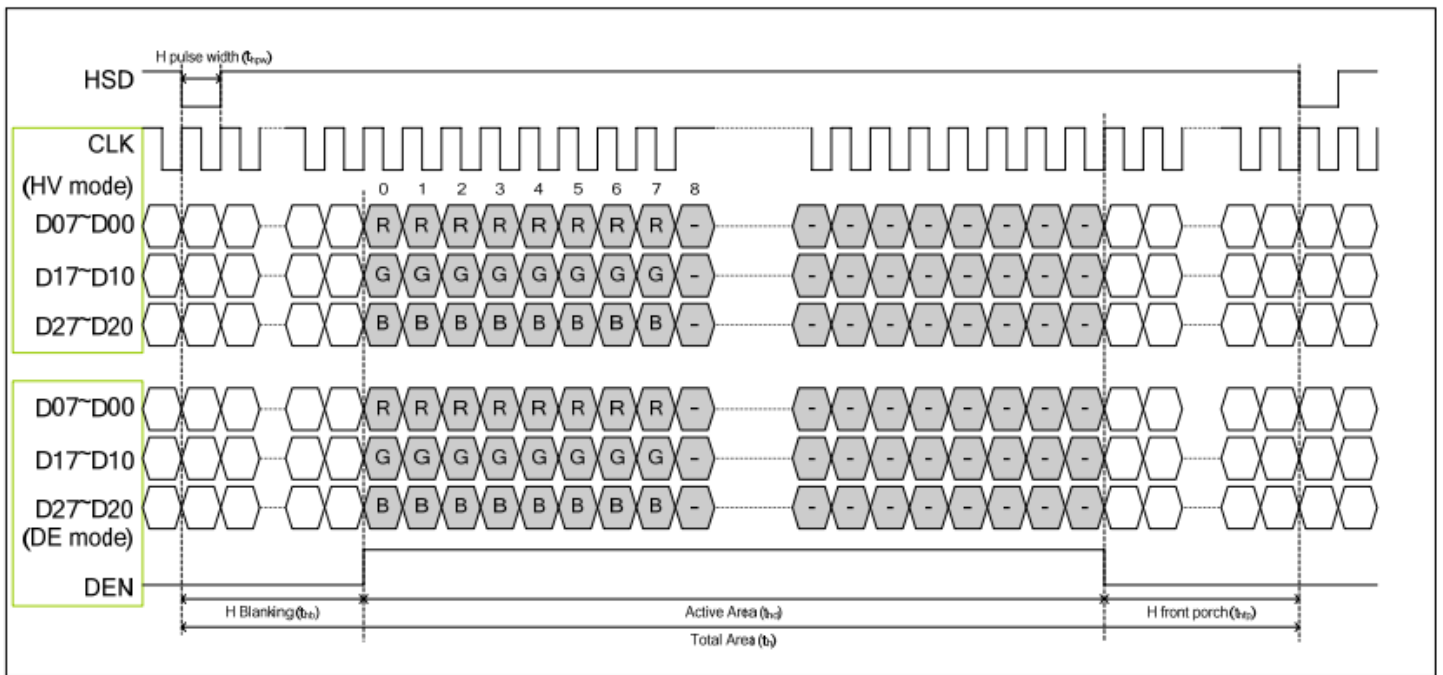

## Vertical Timing

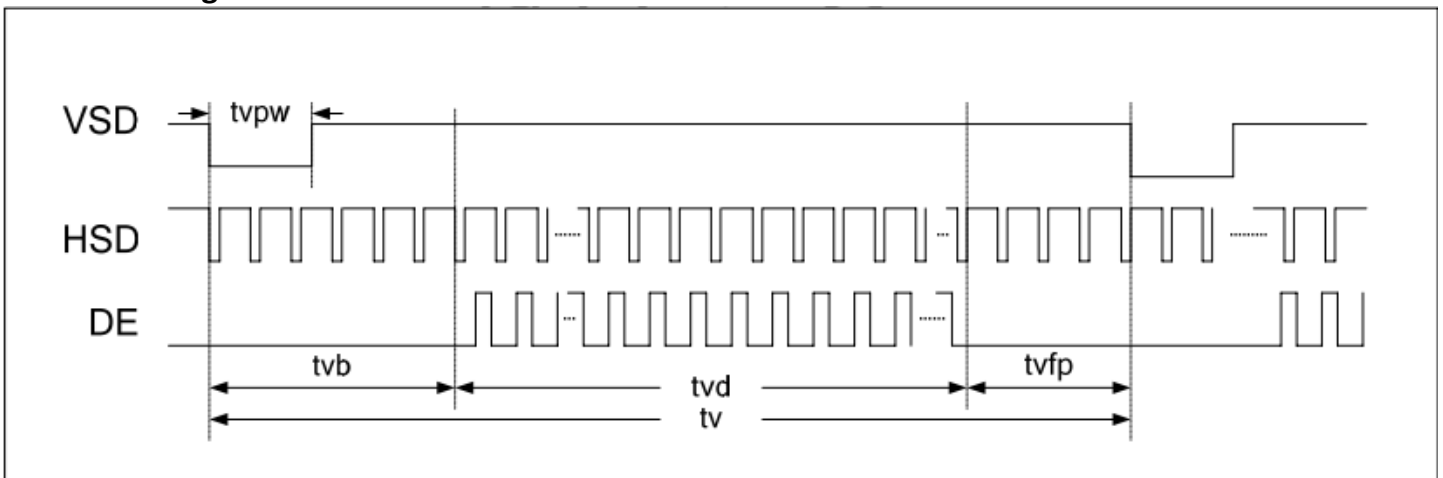

## Parallel 24-bit RGB mode

Parameter	Symbol	Min.	Typ.	Max.	Unit	Conditions
CLKIN Frequency	Fclk	-	40	50	MHz	VDD=3.0V~3.6V
CLKIN Cycle Time	Tclk	20	25	-	ns	-
CLKIN Pulse Duty	Tcwh	40	50	60	%	Tclk
Time from HSD to Source Output	Thso		64		CLKIN	-
Time from HSD to LD	Thld		64		CLKIN	-
Time from HSD to STV	Thstv		2		CLKIN	-
Time from HSD to CKV	Thckv		20		CLKIN	-
Time from HSD to OEV	Thoev		4		CLKIN	-
LD Pulse Width	Twld		10		CLKIN	-
CKV Pulse Width	Twckv		66		CLKIN	-
OEV Pulse Width	Twoev		74		CLKIN	-

## Input Clock and Data Timing

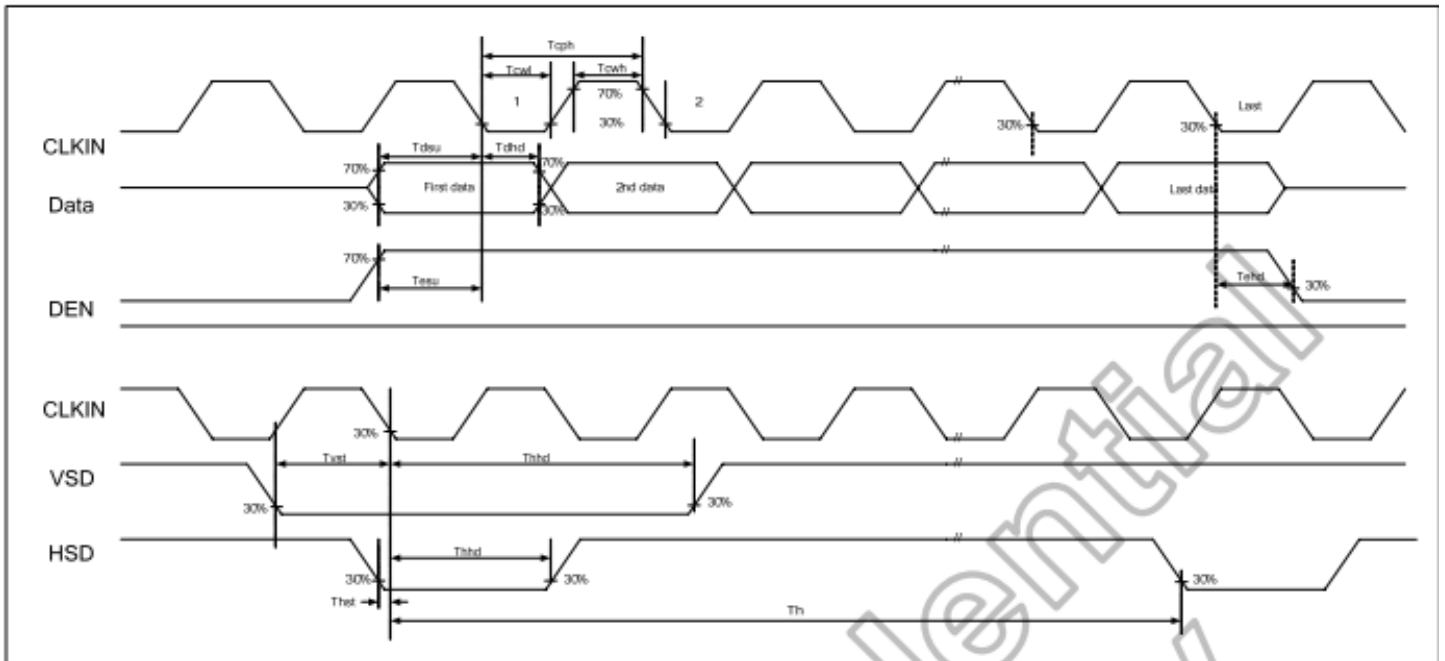

## Source Output Timing

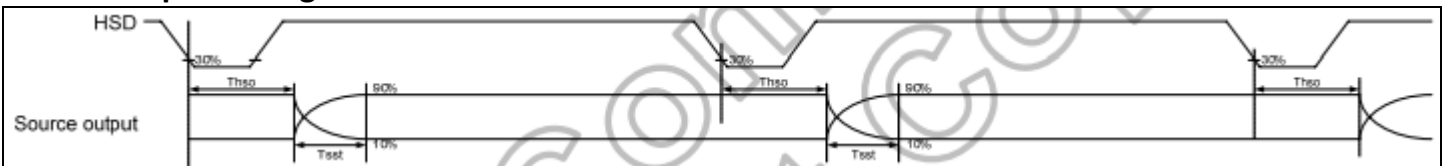

### Vertical Timing HV (Cascade)

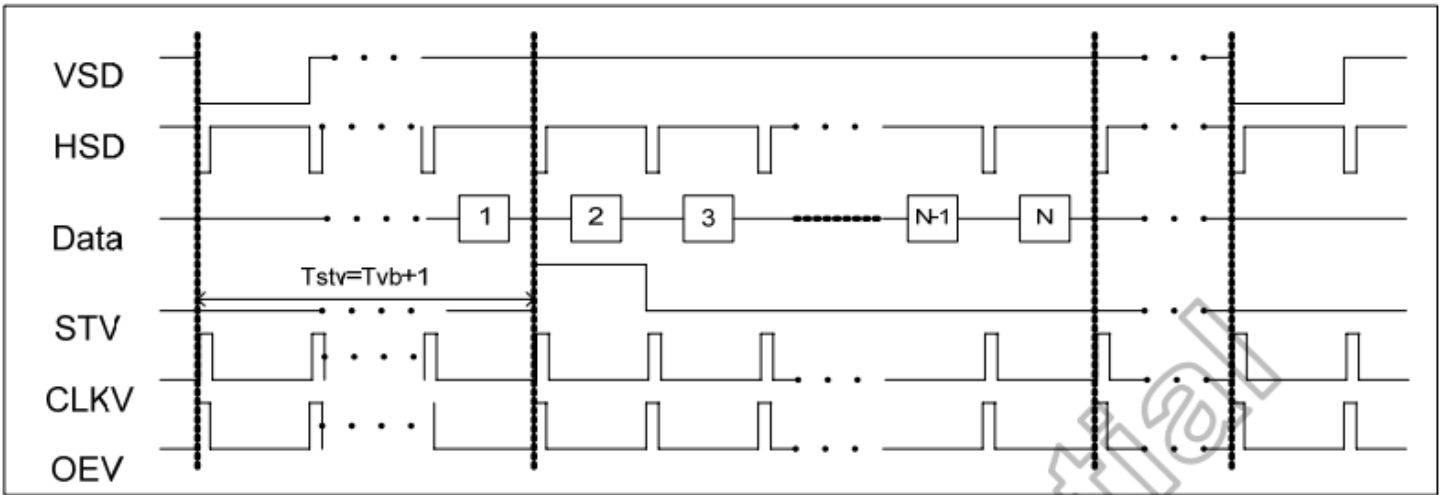

### Vertical Timing DE (Cascade)

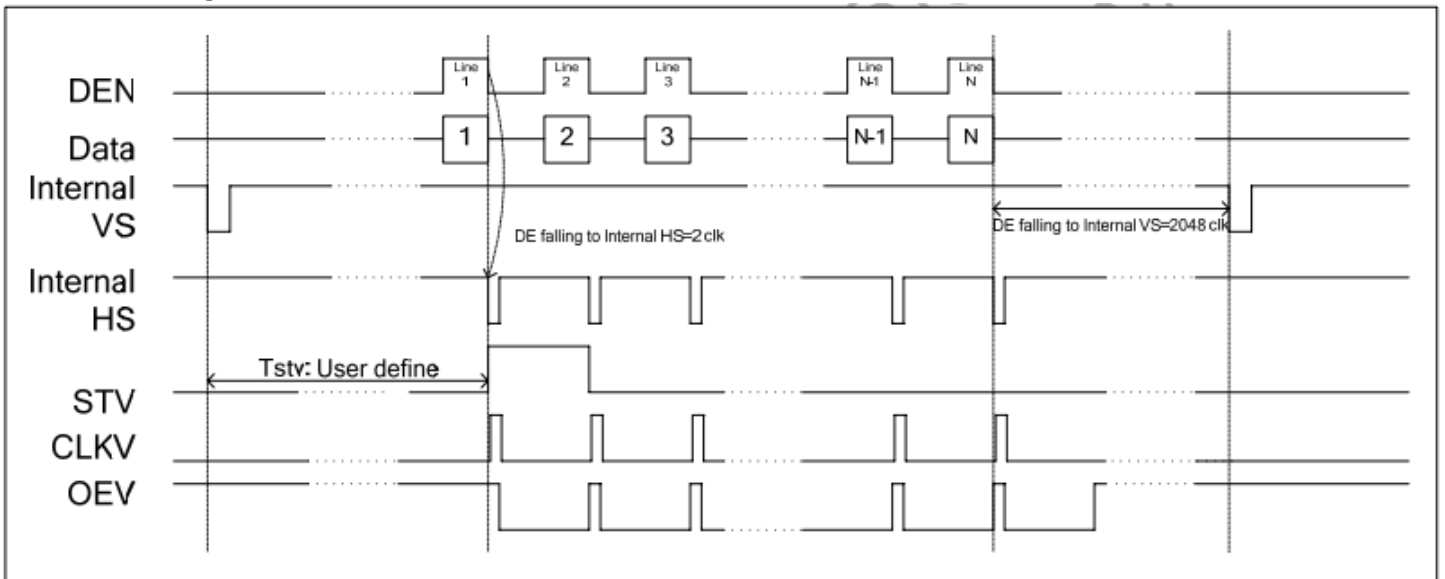

### Gate Output Timing (Cascade)

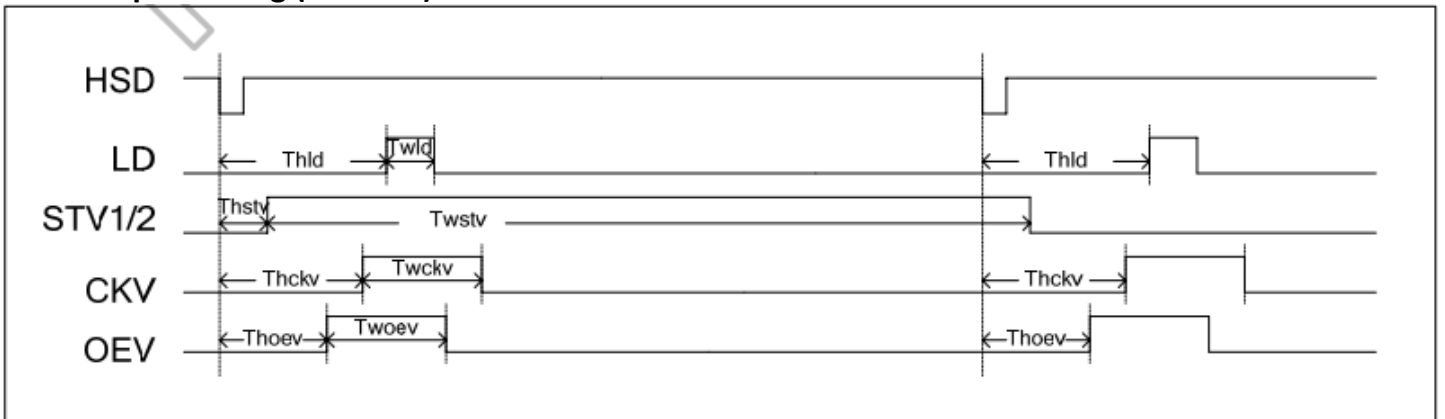

### Vertical Timing HV (Dual Gate)

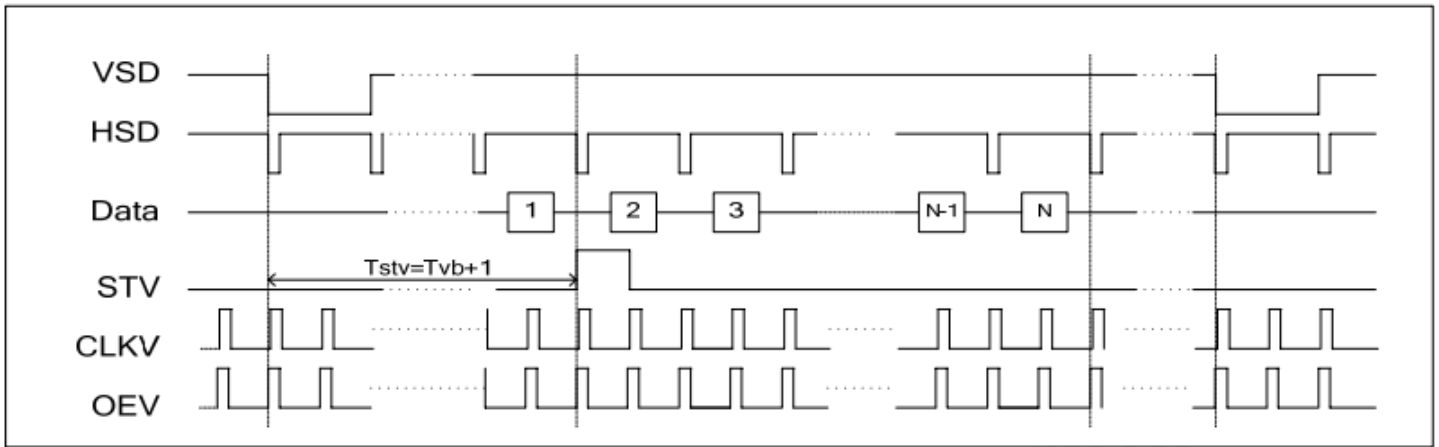

### Vertical Timing DE (Dual Gate)

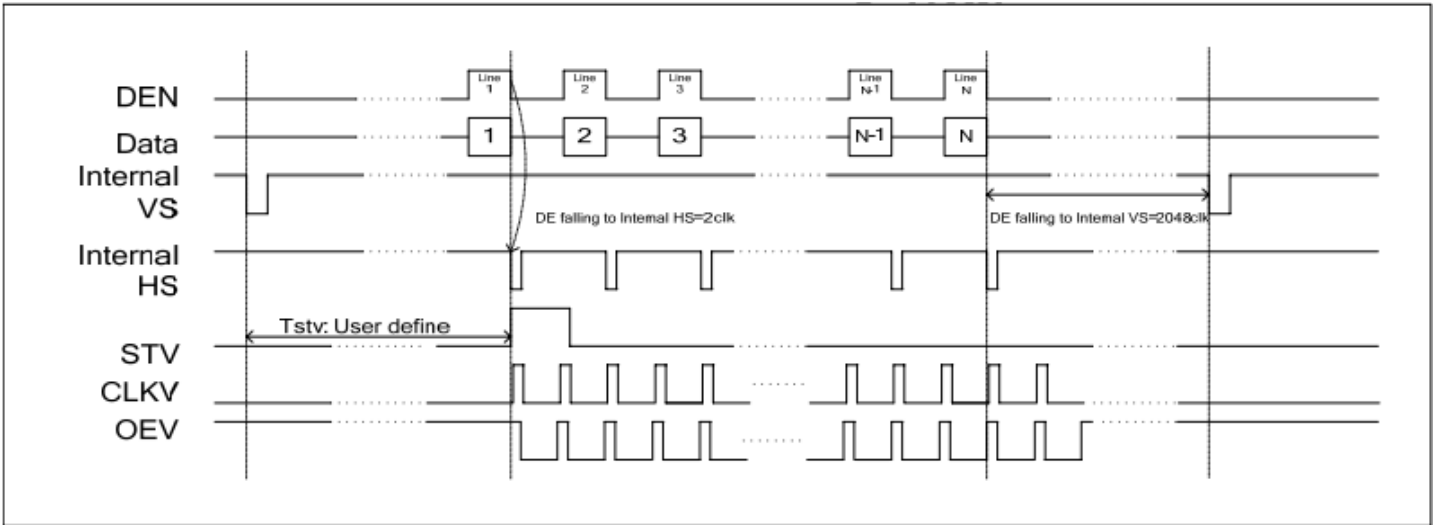

### Gate Output Timing (Dual Gate)

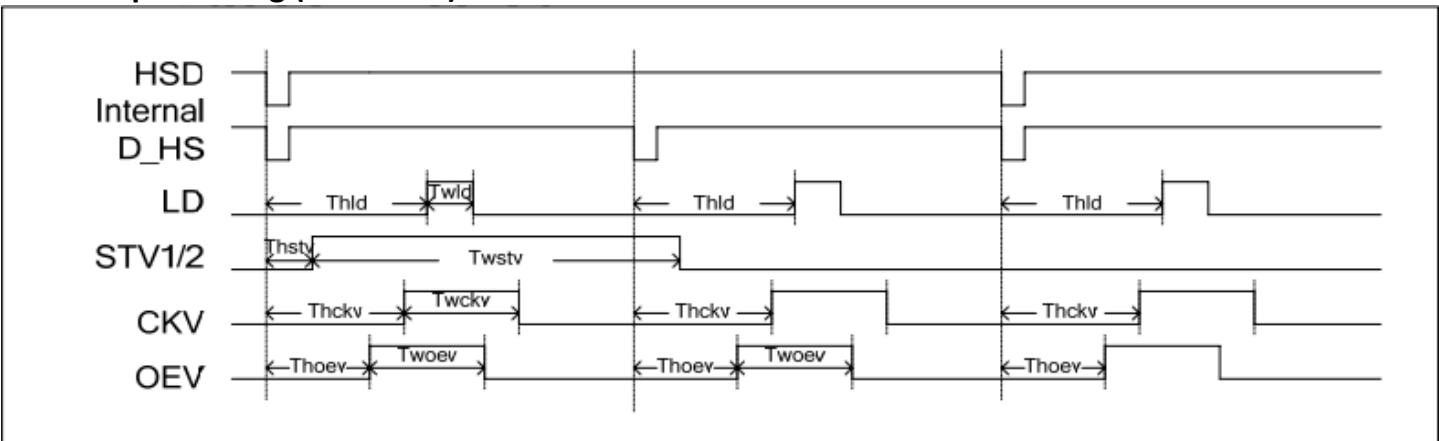

## Power ON/OFF Sequence

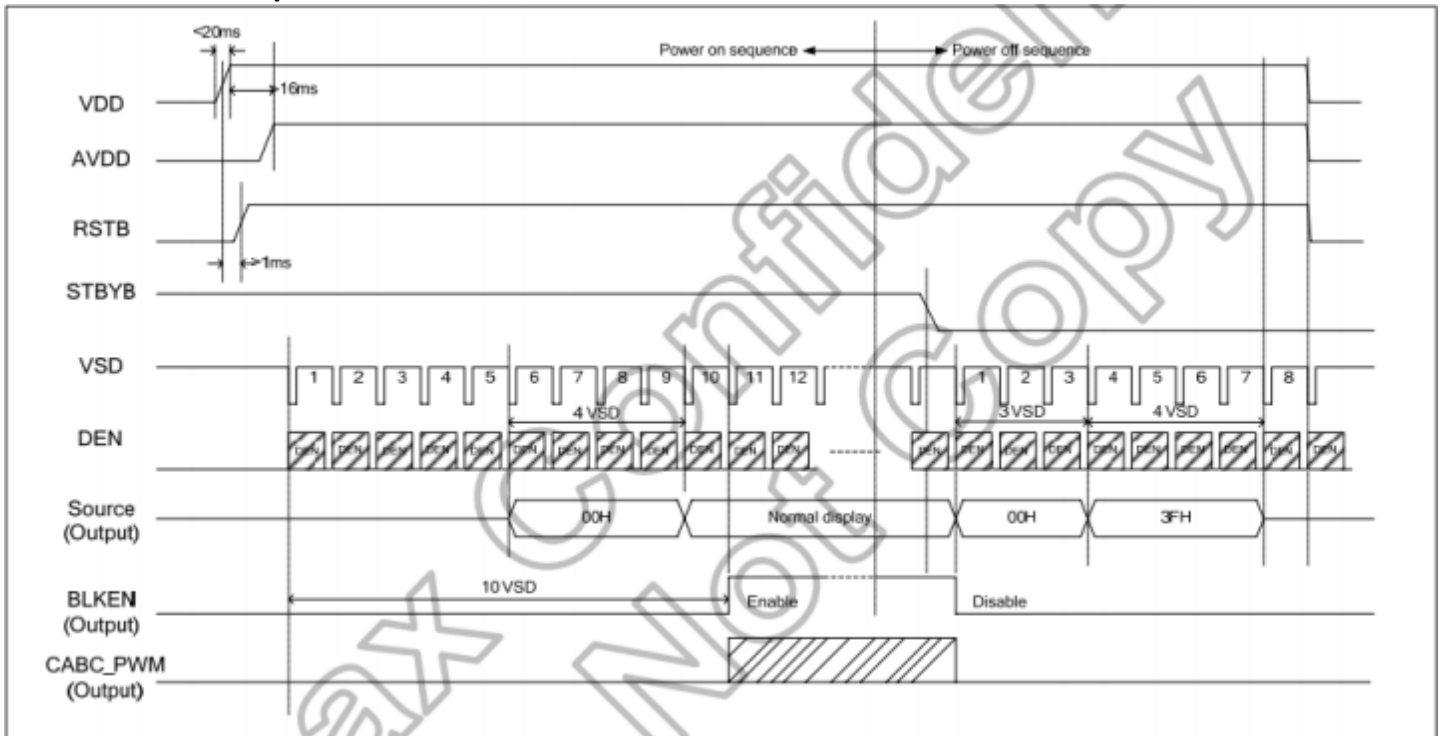

## Enter/Exit Standby Mode Sequence

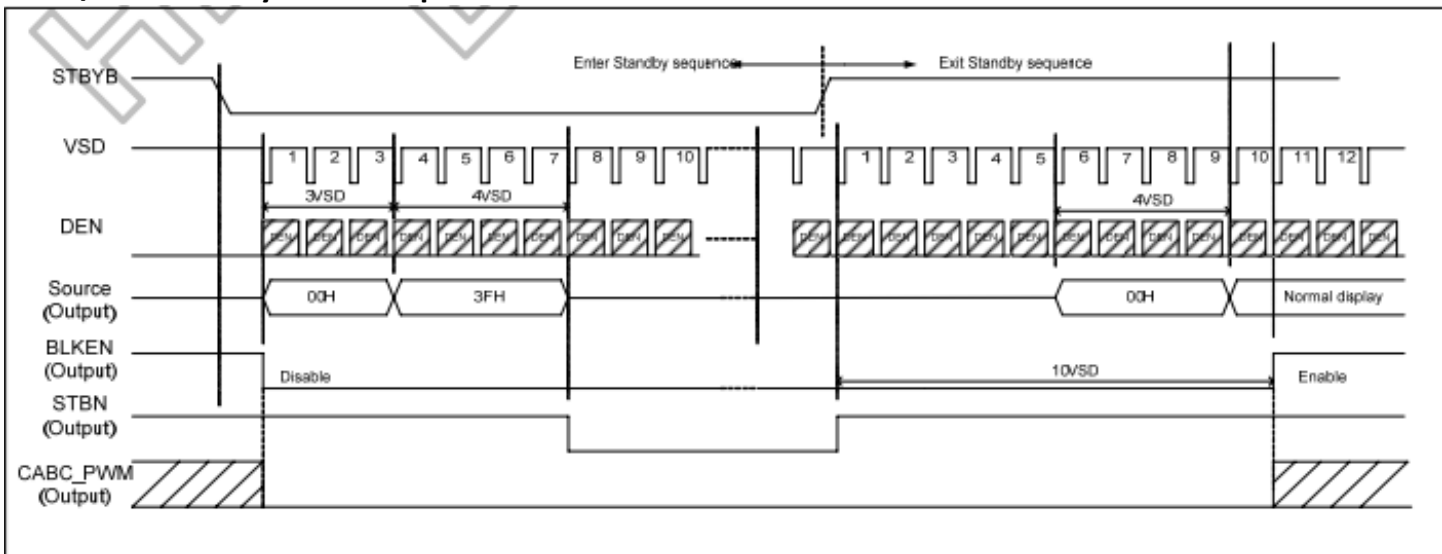

# Timing Characteristics – Capacitive Touch Panel

## Data Transfer Format

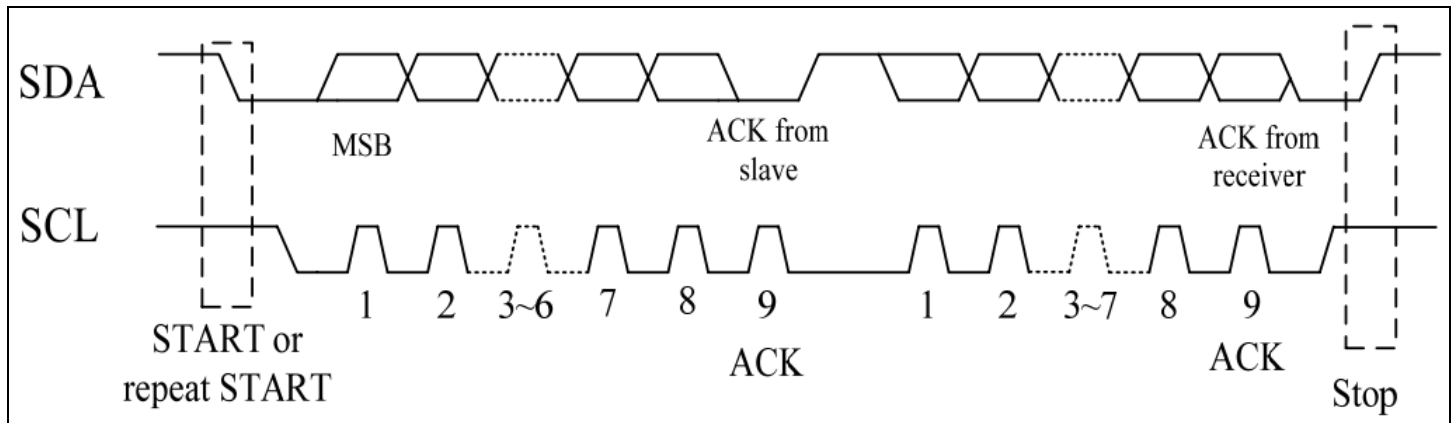

Parameter	Unit	Min	Max
SCL frequency	KHz	0	400
Bus free time between a STOP and START condition	us	4.7	\
Hold time (repeated) START condition	us	4.0	\
Data setup time	ns	250	\
Setup time for a repeated START condition	us	4.7	\
Setup Time for STOP condition	us	4.0	\

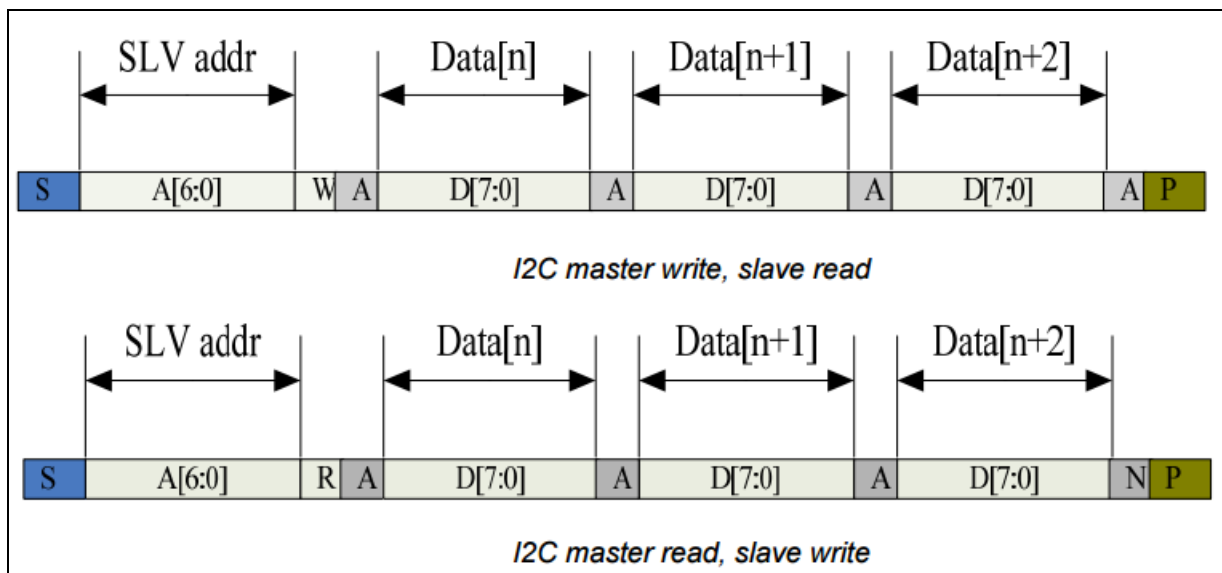



### Power ON Sequence

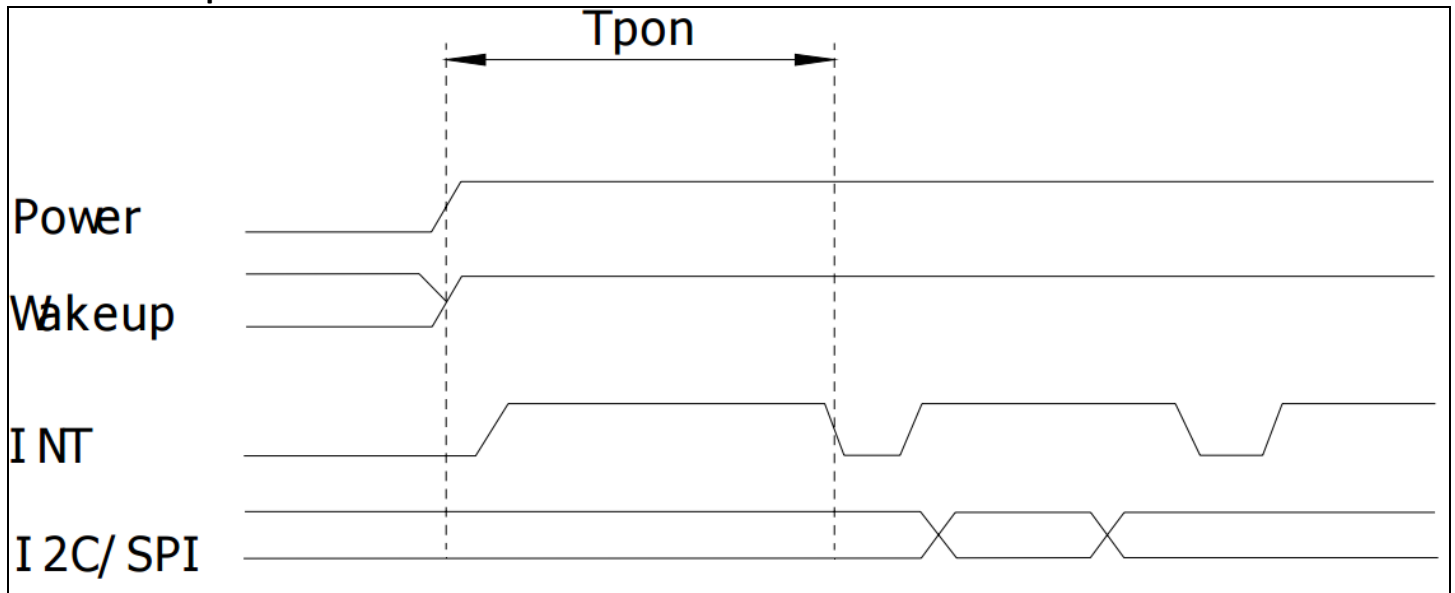

### Reset Sequence

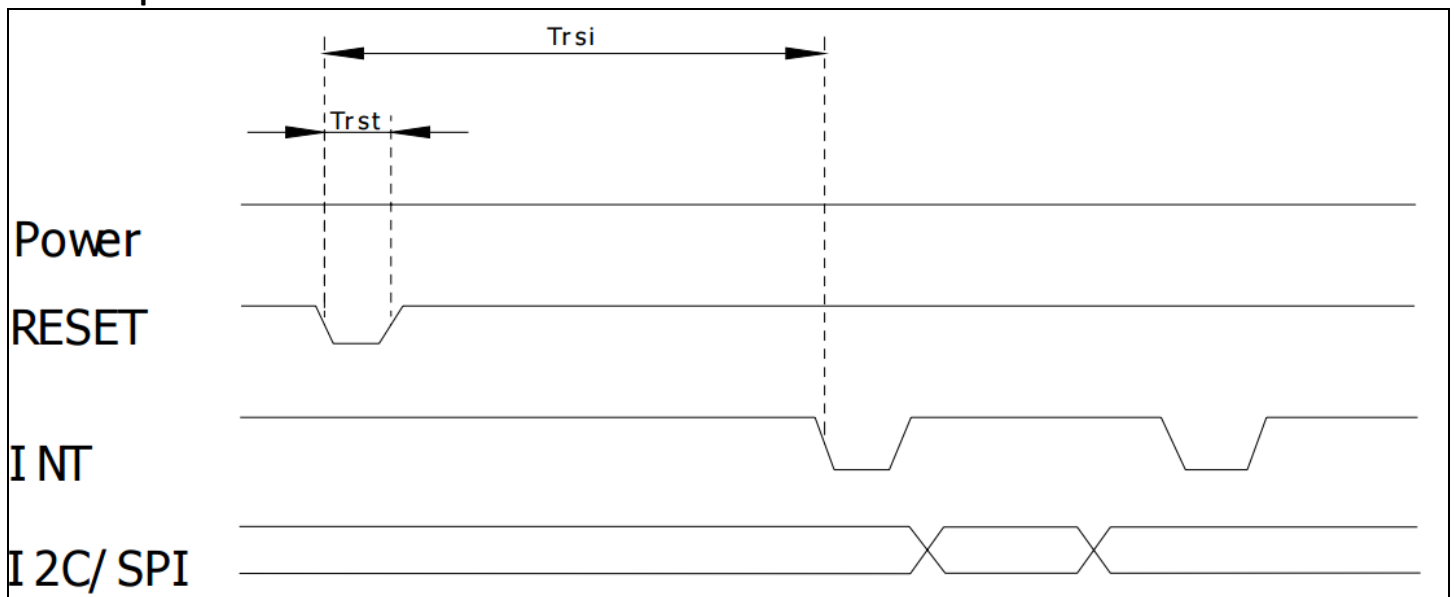

Parameter	Description	Min	Max	Units
Tris	Rise time from 0.1VDD to 0.9VDD	--	10	ms
Tpon	Time of starting to report point after powering on	300	--	ms
Trsi	Time of starting to report point after resetting	300	--	ms
Trst	Reset time	5	--	ms
Twai	Time of starting to report point after waking	300	--	ms
Twak	Wake up time	5	--	ms

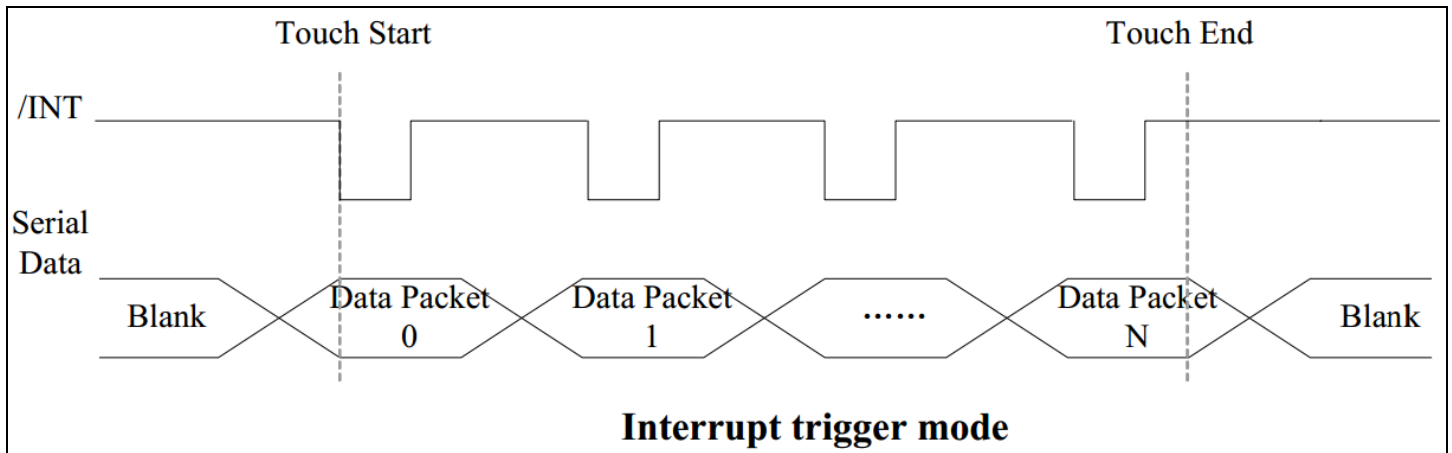

### Sample code to read touch data:

```

i2c_start();
i2c_tx(0x70);           //Slave Address (Write)
i2c_tx(0x00);           //Start reading address
i2c_stop();

i2c_start();
i2c_tx(0x71);           //Slave Address (Read)
for(i=0x00;i<0x1F;i++)
{touchdata_buffer[i] = i2c_rx(1);}
i2c_stop();

```

### Sample code to overwrite default register values:

```

i2c_start();
i2c_tx(0x70);           //Slave Address (Write)
i2c_tx(0xA4);           //ID_G_Mode
i2c_tx(0x01);           //Disable interrupt status to host
i2c_stop();

```

## Quality Information

Test Item	Content of Test	Test Condition	Note
High Temperature storage	Endurance test applying the high storage temperature for a long time.	+80°C , 200hrs	2
Low Temperature storage	Endurance test applying the low storage temperature for a long time.	-30°C , 200hrs	1,2
High Temperature Operation	Endurance test applying the electric stress (voltage & current) and the high thermal stress for a long time.	+70°C 200hrs	2
Low Temperature Operation	Endurance test applying the electric stress (voltage & current) and the low thermal stress for a long time.	-20°C , 200hrs	1,2
High Temperature / Humidity Operation	Endurance test applying the electric stress (voltage & current) and the high thermal with high humidity stress for a long time.	+60°C , 90% RH , 96hrs	1,2
Thermal Shock resistance	Endurance test applying the electric stress (voltage & current) during a cycle of low and high thermal stress.	-20°C,30min -> 25°C,5min ->70°C,30min = 1 cycle 10 cycles	
Vibration test	Endurance test applying vibration to simulate transportation and use.	10-55Hz , 15mm amplitude. 60 sec in each of 3 directions X,Y,Z For 15 minutes	3
Static electricity test	Endurance test applying electric static discharge.	VS=800V, RS=1.5kΩ, CS=100pF One time	

**Note 1:** No condensation to be observed.

**Note 2:** Conducted after 4 hours of storage at 25°C, 0%RH.

**Note 3:** Test performed on product itself, not inside a container.

## Precautions for using LCDs/LCMs

See Precautions at [www.newhavendisplay.com/specs/precautions.pdf](http://www.newhavendisplay.com/specs/precautions.pdf)

## Warranty Information and Terms & Conditions

[http://www.newhavendisplay.com/index.php?main\\_page=terms](http://www.newhavendisplay.com/index.php?main_page=terms)



Компания «ЭлектроПласт» предлагает заключение долгосрочных отношений при поставках импортных электронных компонентов на взаимовыгодных условиях!

Наши преимущества:

- Оперативные поставки широкого спектра электронных компонентов отечественного и импортного производства напрямую от производителей и с крупнейших мировых складов;
- Поставка более 17-ти миллионов наименований электронных компонентов;
- Поставка сложных, дефицитных, либо снятых с производства позиций;
- Оперативные сроки поставки под заказ (от 5 рабочих дней);
- Экспресс доставка в любую точку России;
- Техническая поддержка проекта, помощь в подборе аналогов, поставка прототипов;
- Система менеджмента качества сертифицирована по Международному стандарту ISO 9001;
- Лицензия ФСБ на осуществление работ с использованием сведений, составляющих государственную тайну;
- Поставка специализированных компонентов (Xilinx, Altera, Analog Devices, Intersil, Interpoint, Microsemi, Aeroflex, Peregrine, Syfer, Eurofarad, Texas Instrument, Miteq, Cobham, E2V, MA-COM, Hittite, Mini-Circuits, General Dynamics и др.);

Помимо этого, одним из направлений компании «ЭлектроПласт» является направление «Источники питания». Мы предлагаем Вам помощь Конструкторского отдела:

- Подбор оптимального решения, техническое обоснование при выборе компонента;
- Подбор аналогов;
- Консультации по применению компонента;
- Поставка образцов и прототипов;
- Техническая поддержка проекта;
- Защита от снятия компонента с производства.



#### Как с нами связаться

**Телефон:** 8 (812) 309 58 32 (многоканальный)

**Факс:** 8 (812) 320-02-42

**Электронная почта:** [org@eplast1.ru](mailto:org@eplast1.ru)

**Адрес:** 198099, г. Санкт-Петербург, ул. Калинина, дом 2, корпус 4, литера А.