

Metallized Polypropylene (PP) - Capacitors in Cylindrical Case MKP 6 with High Volume/Capacitance Ratio MKP 6 HP with Higher Current Carrying Capability

Special Features

- Very high volume/capacitance ratio
- Self-healing properties
- With cylindrical aluminium case for bus bar mounting
- Dry construction without electrolyte or oil
- No internal fuse required
- Negative capacitance change versus temperature
- Very low dielectric absorption
- According to RoHS 2011/65/EU
- Customer-specific capacitances or voltages on request

Typical Applications

DC capacitors with high capacitances for applications in power electronics also at non-sinusoidal voltages and currents e.g. in

- Wind power systems
- Inverters

Construction

Dielectric:

Polypropylene (PP) film

Capacitor electrodes:

Vacuum-deposited

Internal construction:

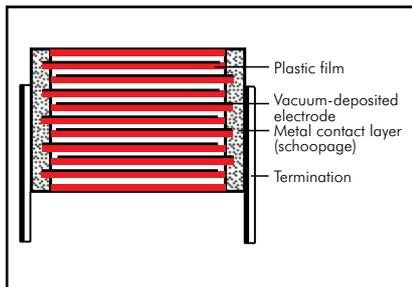

Encapsulation:

Aluminium case with PU-sealing, UL 94 V-0

Terminations:

Screw connection (male or female), screw bolt M12 x 16.

Marking:

Colour: Metallic. Marking: Black on silver label.

Electrical Data

Capacitance range: 75 μF to 4920 μF
Rated voltages: 600 VDC, 700 VDC, 900 VDC, 1100 VDC, 1300 VDC, 1500 VDC
Capacitance tolerances: $\pm 20\%$, $\pm 10\%$ ($\pm 5\%$ available subject to special enquiry)
Operating temperature range: -40°C to $+85^\circ\text{C}$
Insulation resistance at $+20^\circ\text{C}$: ≥ 5000 sec ($\text{M}\Omega \times \mu\text{F}$) (mean value: 20 000 sec)
 Measuring voltage: 100 V/1 min.

Dielectric loss factor

$\tan \delta_0: 2 \times 10^{-4}$

Test voltage between terminals

at $+25^\circ\text{C}$: $1.5 U_{rDC}$, 10sec

Test voltage between terminals and case

at $+25^\circ\text{C}$ and 50 Hz: $3 kV_{AC}$, 1 min.

Dielectric absorption:

0.05 %

Reliability:

Operational life > 100 000 hours

Failure rate < 50 fit (hot spot $\leq 70^\circ\text{C}$)

Mounting Recommendation

Excessive mechanical strain, e.g. pressure or shock onto the capacitor body, is to be avoided during mounting and usage of the capacitors.

Packing

Transportation-safe packing in cardboard boxes.

For further details and graphs please refer to Technical Information.

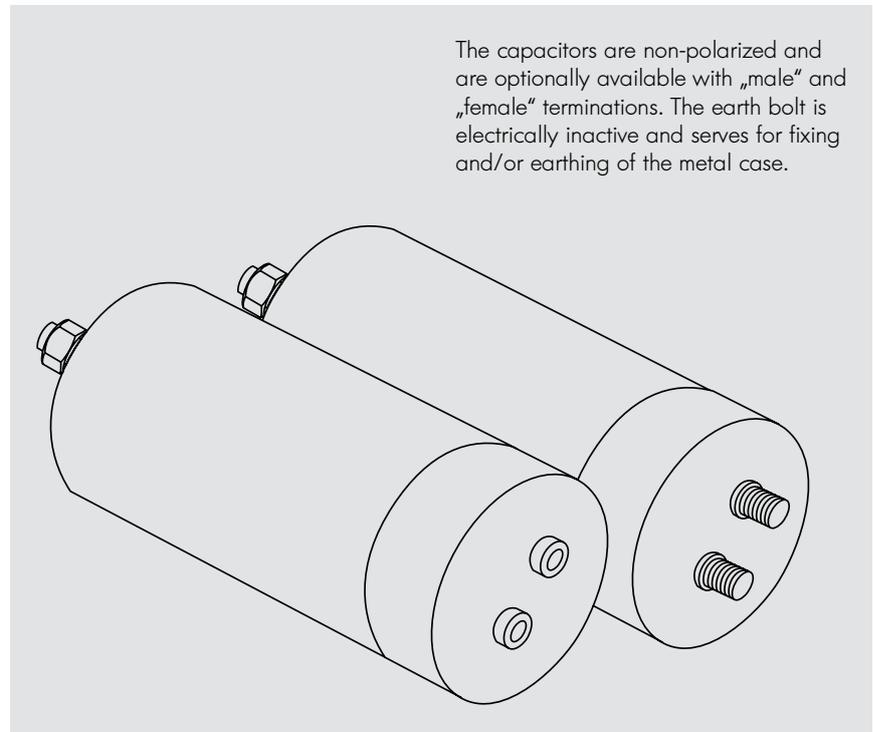

Continuation

General Data

| U _R | C _N | D x L mm | I _{rms} (max.)* A | ESR (1 kHz)* mΩ | L _e nH | Approx. weight g | Bestellnummer |
|----------------|----------------|-------------|-------------------------------|--------------------|----------------------|---------------------|-----------------|
| 600 VDC | 320 μF | 85 x 60 | 25 | 2.1 | < 70 | 380 | DCP6I06320EB00_ |
| | 460 " | 85 x 76 | 25 | 2.1 | < 70 | 480 | DCP6I06460EC00_ |
| | 520 " | 85 x 85 | 30 | 2.0 | < 70 | 540 | DCP6I06520ED00_ |
| | 620 " | 85 x 95 | 30 | 1.9 | < 70 | 600 | DCP6I06620EE00_ |
| | 760 " | 85 x 110 | 30 | 1.7 | < 70 | 690 | DCP6I06760EF00_ |
| | 780 " | 85 x 120 | 30 | 1.7 | < 70 | 700 | DCP6I06780E000_ |
| | 950 " | 85 x 132 | 35 | 1.8 | < 70 | 850 | DCP6I06950E100_ |
| | 1030 " | 85 x 140 | 35 | 1.8 | < 70 | 880 | DCP6I07103EG00_ |
| | 1220 " | 116 x 95 | 40 | 1.7 | < 70 | 1200 | DCP6I07122EN00_ |
| | 1500 " | 116 x 110 | 40 | 1.7 | < 70 | 1390 | DCP6I07150EO00_ |
| | 1640 " | 116 x 120 | 40 | 1.6 | < 70 | 1510 | DCP6I07164EP00_ |
| | 1890 " | 116 x 132 | 40 | 1.6 | < 70 | 1660 | DCP6I07189EQ00_ |
| | 2030 " | 116 x 140 | 40 | 1.6 | < 70 | 1760 | DCP6I07203ER00_ |
| 700 VDC | 230 μF | 85 x 60 | 25 | 1.9 | < 70 | 380 | DCP6K06230EB00_ |
| | 330 " | 85 x 76 | 25 | 1.9 | < 70 | 480 | DCP6K06330EC00_ |
| | 380 " | 85 x 85 | 30 | 1.7 | < 70 | 540 | DCP6K06380ED00_ |
| | 450 " | 85 x 95 | 30 | 1.7 | < 70 | 600 | DCP6K06450EE00_ |
| | 550 " | 85 x 110 | 30 | 1.8 | < 70 | 690 | DCP6K06550EF00_ |
| | 585 " | 85 x 120 | 30 | 1.8 | < 70 | 700 | DCP6K06585E000_ |
| | 690 " | 85 x 132 | 35 | 1.8 | < 70 | 850 | DCP6K06690E100_ |
| | 740 " | 85 x 140 | 35 | 1.8 | < 70 | 880 | DCP6K06740EG00_ |
| | 890 " | 116 x 95 | 40 | 1.7 | < 70 | 1200 | DCP6K06890EN00_ |
| | 1090 " | 116 x 110 | 40 | 1.7 | < 70 | 1390 | DCP6K07109EO00_ |
| | 1190 " | 116 x 120 | 40 | 1.8 | < 70 | 1510 | DCP6K07119EP00_ |
| | 1370 " | 116 x 132 | 40 | 1.8 | < 70 | 1660 | DCP6K07137EQ00_ |
| | 1470 " | 116 x 140 | 40 | 1.8 | < 70 | 1760 | DCP6K07147ER00_ |
| 900 VDC | 190 μF | 85 x 60 | 30 | 1.9 | < 70 | 380 | DCP6N06190EB00_ |
| | 270 " | 85 x 76 | 30 | 1.9 | < 70 | 480 | DCP6N06270EC00_ |
| | 315 " | 85 x 85 | 30 | 1.8 | < 70 | 540 | DCP6N06315ED00_ |
| | 360 " | 85 x 95 | 30 | 1.7 | < 70 | 600 | DCP6N06360EE00_ |
| | 450 " | 85 x 110 | 30 | 1.7 | < 70 | 690 | DCP6N06450EF00_ |
| | 480 " | 85 x 120 | 35 | 1.8 | < 70 | 700 | DCP6N06480E000_ |
| | 550 " | 85 x 132 | 35 | 1.8 | < 70 | 850 | DCP6N06550E100_ |
| | 620 " | 85 x 140 | 35 | 1.8 | < 70 | 880 | DCP6N06620EG00_ |
| | 730 " | 116 x 95 | 40 | 1.7 | < 70 | 1200 | DCP6N06730EN00_ |
| | 900 " | 116 x 110 | 40 | 1.7 | < 70 | 1390 | DCP6N06900EO00_ |
| | 980 " | 116 x 120 | 40 | 1.8 | < 70 | 1510 | DCP6N06980EP00_ |
| | 1130 " | 116 x 132 | 40 | 1.8 | < 70 | 1660 | DCP6N07113EQ00_ |
| | 1200 " | 116 x 140 | 40 | 1.8 | < 70 | 1760 | DCP6N07120ER00_ |
| 1100 VDC | 120 μF | 85 x 60 | 30 | 2.0 | < 70 | 380 | DCP6P06120EB00_ |
| | 170 " | 85 x 76 | 30 | 2.0 | < 70 | 480 | DCP6P06170EC00_ |
| | 200 " | 85 x 85 | 30 | 1.9 | < 70 | 540 | DCP6P06200ED00_ |
| | 230 " | 85 x 95 | 30 | 1.9 | < 70 | 600 | DCP6P06230EE00_ |
| | 290 " | 85 x 110 | 30 | 1.8 | < 70 | 690 | DCP6P06290EF00_ |
| | 325 " | 85 x 120 | 40 | 1.8 | < 70 | 700 | DCP6P06325E000_ |
| | 360 " | 85 x 132 | 40 | 1.8 | < 70 | 850 | DCP6P06360E100_ |
| | 390 " | 85 x 140 | 40 | 2.0 | < 70 | 880 | DCP6P06390EG00_ |
| | 470 " | 116 x 95 | 40 | 1.8 | < 70 | 1200 | DCP6P06470EN00_ |
| | 580 " | 116 x 110 | 40 | 1.8 | < 70 | 1390 | DCP6P06580EO00_ |
| | 630 " | 116 x 120 | 40 | 1.7 | < 70 | 1510 | DCP6P06630EP00_ |
| | 720 " | 116 x 132 | 40 | 1.7 | < 70 | 1660 | DCP6P06720EQ00_ |
| | 780 " | 116 x 140 | 40 | 1.6 | < 70 | 1760 | DCP6P06780ER00_ |

Contacts can handle: peak currents \hat{I} up to 5 kA
surge currents I_S up to 20 kA

Customer-specific capacitances or voltages on request

* General guide

| | |
|-------------------------|-------------|
| Part number completion: | |
| Tolerance: | 20 % = M |
| | 10 % = K |
| | 5 % = J |
| Packing: | bulk = S |
| Connection: | male = OM |
| | female = OF |

Rights reserved to amend design data without prior notification.

Continuation

General Data

| U_R | C_N | D x L mm | I_{rms} (max.)* A | ESR (1 kHz)* m Ω | L_e nH | Approx. weight g | Part number |
|----------|------------|-------------|------------------------|----------------------------|-------------|---------------------|-----------------|
| 1300 VDC | 85 μ F | 85 x 60 | 30 | 2.1 | < 70 | 380 | DCP6R25850EB00_ |
| | 120 " | 85 x 76 | 30 | 2.1 | < 70 | 480 | DCP6R26120EC00_ |
| | 135 " | 85 x 85 | 30 | 1.9 | < 70 | 540 | DCP6R26135ED00_ |
| | 160 " | 85 x 95 | 30 | 1.9 | < 70 | 600 | DCP6R26160EE00_ |
| | 200 " | 85 x 110 | 30 | 1.8 | < 70 | 690 | DCP6R26200EF00_ |
| | 215 " | 85 x 120 | 30 | 1.8 | < 70 | 700 | DCP6R26215E000_ |
| | 250 " | 85 x 132 | 40 | 2.2 | < 70 | 850 | DCP6R26250E100_ |
| | 270 " | 85 x 140 | 40 | 2.2 | < 70 | 880 | DCP6R26270EG00_ |
| | 320 " | 116 x 95 | 40 | 1.8 | < 70 | 1200 | DCP6R26320EN00_ |
| | 390 " | 116 x 110 | 40 | 1.8 | < 70 | 1390 | DCP6R26390EO00_ |
| | 430 " | 116 x 120 | 40 | 1.7 | < 70 | 1510 | DCP6R26430EP00_ |
| | 490 " | 116 x 132 | 40 | 1.7 | < 70 | 1660 | DCP6R26490EQ00_ |
| | 530 " | 116 x 140 | 40 | 1.6 | < 70 | 1760 | DCP6R26530ER00_ |
| | 1500 VDC | 75 μ F | 85 x 60 | 25 | 2.5 | < 70 | 380 |
| 110 " | | 85 x 76 | 25 | 2.5 | < 70 | 480 | DCP6S06110EC00_ |
| 120 " | | 85 x 85 | 25 | 2.3 | < 70 | 540 | DCP6S06120ED00_ |
| 145 " | | 85 x 95 | 30 | 2.3 | < 70 | 600 | DCP6S06145EE00_ |
| 180 " | | 85 x 110 | 30 | 2.3 | < 70 | 690 | DCP6S06180EF00_ |
| 195 " | | 85 x 120 | 40 | 2.4 | < 70 | 700 | DCP6S06195E000_ |
| 225 " | | 85 x 132 | 40 | 2.4 | < 70 | 850 | DCP6S06225E100_ |
| 240 " | | 85 x 140 | 40 | 2.5 | < 70 | 880 | DCP6S06240EG00_ |
| 290 " | | 116 x 95 | 40 | 1.8 | < 70 | 1200 | DCP6S06290EN00_ |
| 355 " | | 116 x 110 | 40 | 1.8 | < 70 | 1390 | DCP6S06355EO00_ |
| 390 " | | 116 x 120 | 40 | 1.7 | < 70 | 1510 | DCP6S06390EP00_ |
| 445 " | | 116 x 132 | 40 | 1.7 | < 70 | 1660 | DCP6S06445EQ00_ |
| 480 " | | 116 x 140 | 40 | 1.7 | < 70 | 1760 | DCP6S06480ER00_ |

Contacts can handle: peak currents \hat{I} up to 5 kA
surge currents I_S up to 20 kA

Customer-specific capacitances or voltages on request

* General guide

female

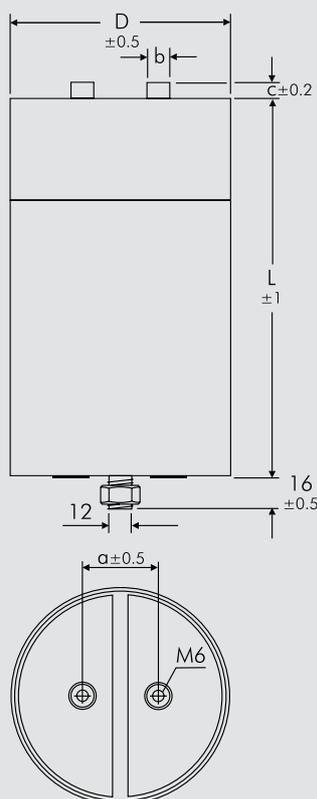

male

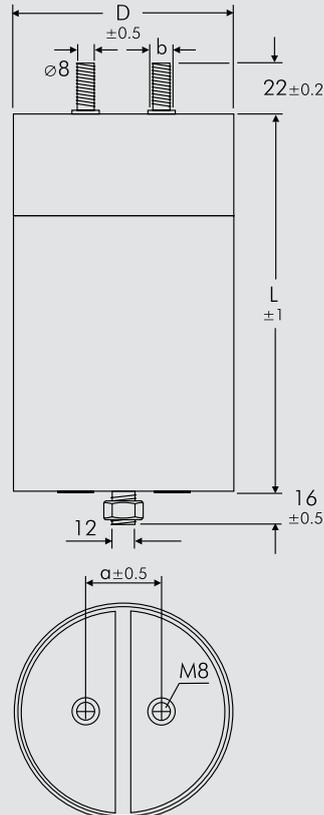

Part number completion:

Tolerance: 20 % = M
10 % = K
5 % = J
Packing: bulk = S
Connection: male = 0M
female = 0F

| D | L | a | b | c |
|-----|-----|----|----|---|
| 85 | 60 | 32 | 12 | 6 |
| 85 | 76 | 32 | 12 | 6 |
| 85 | 85 | 32 | 12 | 6 |
| 85 | 95 | 32 | 12 | 6 |
| 85 | 110 | 32 | 12 | 6 |
| 85 | 120 | 32 | 12 | 6 |
| 85 | 132 | 32 | 12 | 6 |
| 85 | 140 | 32 | 12 | 6 |
| 116 | 95 | 50 | 14 | 5 |
| 116 | 110 | 50 | 14 | 5 |
| 116 | 120 | 50 | 14 | 5 |
| 116 | 132 | 50 | 14 | 5 |
| 116 | 140 | 50 | 14 | 5 |

Dims. in mm.

Rights reserved to amend design data without prior notification.



Continuation: Versions with increased dimensioning for higher current carrying capability

General Data

| U _R | C _N | D x L mm | I _{rms} (max.)* A | ESR (1 kHz)* mΩ | L _e nH | Approx. weight g | Part number |
|----------------|----------------|-------------|-------------------------------|--------------------|----------------------|---------------------|-----------------|
| 600 VDC | 640 μF | 85 x 110 | 50 | 1.3 | < 50 | 690 | DCHPIO6640EF00_ |
| | 920 " | 85 x 140 | 50 | 1.3 | < 50 | 880 | DCHPIO6920EG00_ |
| | 1040 " | 85 x 155 | 60 | 1.3 | < 50 | 980 | DCHPIO7104EH00_ |
| | 1240 " | 85 x 185 | 60 | 1.3 | < 50 | 1165 | DCHPIO7124EI00_ |
| | 1520 " | 85 x 210 | 60 | 1.2 | < 50 | 1400 | DCHPIO7152E200_ |
| | 1660 " | 85 x 235 | 60 | 1.2 | < 50 | 1480 | DCHPIO7166EJ00_ |
| | 1900 " | 85 x 252 | 60 | 1.2 | < 50 | 1590 | DCHPIO7190EK00_ |
| | 2060 " | 85 x 260 | 60 | 1.2 | < 50 | 1640 | DCHPIO7206EL00_ |
| | 2490 " | 85 x 345 | 70 | 1.0 | < 50 | 2190 | DCHPIO7249EM00_ |
| | 1260 " | 116 x 110 | 80 | 1.2 | < 50 | 1385 | DCHPIO7126EO00_ |
| | 1820 " | 116 x 140 | 80 | 1.2 | < 50 | 1765 | DCHPIO7182ER00_ |
| | 2060 " | 116 x 158 | 80 | 1.1 | < 50 | 1990 | DCHPIO7206ES00_ |
| | 2440 " | 116 x 185 | 80 | 1.1 | < 50 | 2330 | DCHPIO7244ET00_ |
| | 3000 " | 116 x 215 | 80 | 1.0 | < 50 | 2710 | DCHPIO7300EU00_ |
| | 3280 " | 116 x 230 | 90 | 1.0 | < 50 | 2900 | DCHPIO7328E700_ |
| | 3780 " | 116 x 255 | 90 | 1.0 | < 50 | 3210 | DCHPIO7378EV00_ |
| | 4060 " | 116 x 295 | 90 | 1.0 | < 50 | 3720 | DCHPIO7406EW00_ |
| | 4920 " | 116 x 342 | 100 | 0.7 | < 50 | 4350 | DCHPIO7492EX00_ |
| 700 VDC | 460 μF | 85 x 110 | 50 | 1.3 | < 50 | 690 | DCHPK06460EF00_ |
| | 660 " | 85 x 140 | 50 | 1.3 | < 50 | 880 | DCHPK06660EG00_ |
| | 760 " | 85 x 155 | 60 | 1.2 | < 50 | 980 | DCHPK06760EH00_ |
| | 900 " | 85 x 185 | 60 | 1.2 | < 50 | 1165 | DCHPK06900EI00_ |
| | 1100 " | 85 x 210 | 60 | 1.2 | < 50 | 1400 | DCHPK07110E200_ |
| | 1200 " | 85 x 235 | 60 | 1.2 | < 50 | 1480 | DCHPK07120EJ00_ |
| | 1380 " | 85 x 252 | 70 | 1.1 | < 50 | 1590 | DCHPK07138EK00_ |
| | 1480 " | 85 x 260 | 70 | 1.1 | < 50 | 1640 | DCHPK07148EL00_ |
| | 1800 " | 85 x 345 | 80 | 1.0 | < 50 | 2190 | DCHPK07180EM00_ |
| | 920 " | 116 x 110 | 80 | 1.3 | < 50 | 1385 | DCHPK06920EO00_ |
| | 1320 " | 116 x 140 | 80 | 1.3 | < 50 | 1765 | DCHPK07132ER00_ |
| | 1500 " | 116 x 158 | 80 | 1.3 | < 50 | 1990 | DCHPK07150ES00_ |
| | 1780 " | 116 x 185 | 80 | 1.2 | < 50 | 2330 | DCHPK07178ET00_ |
| | 2180 " | 116 x 215 | 90 | 1.2 | < 50 | 2710 | DCHPK07218EU00_ |
| | 2380 " | 116 x 230 | 90 | 1.0 | < 50 | 2900 | DCHPK07238E700_ |
| | 2740 " | 116 x 255 | 90 | 1.0 | < 50 | 3210 | DCHPK07274EV00_ |
| | 2940 " | 116 x 295 | 90 | 1.0 | < 50 | 3720 | DCHPK07294EW00_ |
| | 3570 " | 116 x 342 | 110 | 0.7 | < 50 | 4350 | DCHPK07357EX00_ |
| 900 VDC | 380 μF | 85 x 110 | 50 | 1.4 | < 50 | 690 | DCHPN06380EF00_ |
| | 540 " | 85 x 140 | 50 | 1.4 | < 50 | 880 | DCHPN06540EG00_ |
| | 630 " | 85 x 155 | 60 | 1.3 | < 50 | 980 | DCHPN06630EH00_ |
| | 720 " | 85 x 185 | 60 | 1.3 | < 50 | 1165 | DCHPN06720EI00_ |
| | 900 " | 85 x 210 | 60 | 1.1 | < 50 | 1400 | DCHPN06900E200_ |
| | 1000 " | 85 x 235 | 70 | 1.0 | < 50 | 1480 | DCHPN07100EJ00_ |
| | 1140 " | 85 x 252 | 70 | 0.9 | < 50 | 1590 | DCHPN07114EK00_ |
| | 1240 " | 85 x 260 | 70 | 0.9 | < 50 | 1640 | DCHPN07124EL00_ |
| | 1500 " | 85 x 345 | 80 | 0.7 | < 50 | 2190 | DCHPN07150EM00_ |

Contacts can handle: peak currents \hat{I} up to 10 kA
surge currents I_s up to 40 kA

Customer-specific capacitances or voltages on request

* General guide

| Part number completion: | |
|-------------------------|-------------|
| Tolerance: | 20 % = M |
| | 10 % = K |
| | 5 % = J |
| Packing: | bulk = S |
| Connection: | male = OM |
| | female = OF |

Rights reserved to amend design data without prior notification.

Continuation page 131

Continuation

General Data

| U _R | C _N | D x L mm | I _{rms} (max.)* A | ESR (1 kHz)* mΩ | L _e nH | Approx. weight g | Part number |
|----------------|----------------|-------------|-------------------------------|--------------------|----------------------|---------------------|-----------------|
| 900 VDC | 760 μF | 116 x 110 | 80 | 1.3 | < 50 | 1385 | DCHPN06760EO00_ |
| | 1100 " | 116 x 140 | 80 | 1.3 | < 50 | 1765 | DCHPN07110ER00_ |
| | 1240 " | 116 x 158 | 80 | 1,3 | < 50 | 1990 | DCHPN07124ES00_ |
| | 1460 " | 116 x 185 | 80 | 1.2 | < 50 | 2330 | DCHPN07146ET00_ |
| | 1800 " | 116 x 215 | 90 | 1.2 | < 50 | 2710 | DCHPN07180EU00_ |
| | 1960 " | 116 x 230 | 90 | 1.0 | < 50 | 2900 | DCHPN07196E700_ |
| | 2260 " | 116 x 255 | 90 | 1.0 | < 50 | 3210 | DCHPN07226EV00_ |
| | 2400 " | 116 x 295 | 90 | 1.0 | < 50 | 3720 | DCHPN07240EW00_ |
| | 2940 " | 116 x 342 | 110 | 0.7 | < 50 | 4350 | DCHPN07294EX00_ |
| 1100 VDC | 240 μF | 85 x 110 | 50 | 1.3 | < 50 | 690 | DCHPP06240EF00_ |
| | 340 " | 85 x 140 | 50 | 1.2 | < 50 | 880 | DCHPP06340EG00_ |
| | 400 " | 85 x 155 | 50 | 1.2 | < 50 | 980 | DCHPP06400EH00_ |
| | 460 " | 85 x 185 | 50 | 1.2 | < 50 | 1165 | DCHPP06460EI00_ |
| | 580 " | 85 x 210 | 60 | 1.2 | < 50 | 1400 | DCHPP06580E200_ |
| | 640 " | 85 x 235 | 60 | 1.1 | < 50 | 1480 | DCHPP06640EJ00_ |
| | 720 " | 85 x 252 | 60 | 1.1 | < 50 | 1590 | DCHPP06720EK00_ |
| | 780 " | 85 x 260 | 60 | 1.2 | < 50 | 1640 | DCHPP06780EL00_ |
| | 960 " | 85 x 345 | 80 | 1.0 | < 50 | 2190 | DCHPP06960EM00_ |
| | 480 " | 116 x 110 | 80 | 1.4 | < 50 | 1385 | DCHPP06480EO00_ |
| | 700 " | 116 x 140 | 80 | 1.3 | < 50 | 1765 | DCHPP06700ER00_ |
| | 780 " | 116 x 158 | 80 | 1.3 | < 50 | 1990 | DCHPP06780ES00_ |
| | 940 " | 116 x 185 | 80 | 1.3 | < 50 | 2330 | DCHPP06940ET00_ |
| | 1160 " | 116 x 215 | 90 | 1.2 | < 50 | 2710 | DCHPP07116EU00_ |
| | 1260 " | 116 x 230 | 90 | 1.2 | < 50 | 2900 | DCHPP07126E700_ |
| | 1440 " | 116 x 255 | 90 | 1.1 | < 50 | 3210 | DCHPP07144EV00_ |
| | 1560 " | 116 x 295 | 90 | 1.0 | < 50 | 3720 | DCHPP07156EV00_ |
| 1890 " | 116 x 342 | 110 | 0.8 | < 50 | 4350 | DCHPP07189EX00_ | |
| 1300 VDC | 170 μF | 85 x 110 | 50 | 1.3 | < 50 | 690 | DCHPR26170EF00_ |
| | 240 " | 85 x 140 | 50 | 1.3 | < 50 | 880 | DCHPR26240EG00_ |
| | 270 " | 85 x 155 | 50 | 1.2 | < 50 | 980 | DCHPR26270EH00_ |
| | 320 " | 85 x 185 | 60 | 1.2 | < 50 | 1165 | DCHPR26320EI00_ |
| | 400 " | 85 x 210 | 60 | 1.2 | < 50 | 1400 | DCHPR26400E200_ |
| | 440 " | 85 x 235 | 60 | 1.1 | < 50 | 1480 | DCHPR26440EJ00_ |
| | 500 " | 85 x 252 | 60 | 1.1 | < 50 | 1590 | DCHPR26500EK00_ |
| | 540 " | 85 x 260 | 60 | 1.2 | < 50 | 1640 | DCHPR26540EL00_ |
| | 660 " | 85 x 345 | 80 | 1.0 | < 50 | 2190 | DCHPR26660EM00_ |
| | 330 " | 116 x 110 | 80 | 1.4 | < 50 | 1385 | DCHPR26330EO00_ |
| | 480 " | 116 x 140 | 80 | 1.4 | < 50 | 1765 | DCHPR26480ER00_ |
| | 540 " | 116 x 158 | 80 | 1.3 | < 50 | 1990 | DCHPR26540ES00_ |
| | 640 " | 116 x 185 | 80 | 1.3 | < 50 | 2330 | DCHPR26640ET00_ |
| | 780 " | 116 x 215 | 90 | 1.2 | < 50 | 2710 | DCHPR26780EU00_ |
| | 860 " | 116 x 230 | 90 | 1.2 | < 50 | 2900 | DCHPR26860E700_ |
| | 980 " | 116 x 255 | 90 | 1.1 | < 50 | 3210 | DCHPR26980EV00_ |
| | 1060 " | 116 x 295 | 90 | 1.1 | < 50 | 3720 | DCHPR27106EV00_ |
| 1290 " | 116 x 342 | 110 | 0.8 | < 50 | 4350 | DCHPR27129EX00_ | |

Contacts can handle: peak currents \hat{I} up to 10 kA
surge currents I_S up to 40 kA

Customer-specific capacitances or voltages on request

* General guide

Part number completion:

Tolerance: 20 % = M

10 % = K

5 % = J

Packing: bulk = S

Connection: male = 0M

female = 0F

Rights reserved to amend design data without prior notification.

Continuation page 132

Continuation

General Data

| U_R | C_N | D x L mm | I_{rms} (max.)* A | ESR (1 kHz)* m Ω | L_e nH | Approx. weight g | Part number |
|----------|-------------|-------------|------------------------|----------------------------|-------------|---------------------|-----------------|
| 1500 VDC | 150 μ F | 85 x 110 | 50 | 1.3 | < 50 | 690 | DCHPS06150EF00_ |
| | 220 " | 85 x 140 | 50 | 1.3 | < 50 | 880 | DCHPS06220EG00_ |
| | 240 " | 85 x 155 | 50 | 1.2 | < 50 | 980 | DCHPS06240EH00_ |
| | 290 " | 85 x 185 | 60 | 1.2 | < 50 | 1165 | DCHPS06290EI00_ |
| | 360 " | 85 x 210 | 60 | 1.2 | < 50 | 1400 | DCHPS06360EJ00_ |
| | 390 " | 85 x 235 | 60 | 1.1 | < 50 | 1480 | DCHPS06390EK00_ |
| | 450 " | 85 x 252 | 60 | 1.1 | < 50 | 1590 | DCHPS06450EL00_ |
| | 480 " | 85 x 260 | 60 | 1.1 | < 50 | 1640 | DCHPS06480EM00_ |
| | 585 " | 85 x 345 | 80 | 1.0 | < 50 | 2190 | DCHPS06585EO00_ |
| | 300 " | 116 x 110 | 80 | 1.5 | < 50 | 1385 | DCHPS06300EP00_ |
| | 430 " | 116 x 140 | 80 | 1.4 | < 50 | 1765 | DCHPS06430ER00_ |
| | 490 " | 116 x 158 | 80 | 1.4 | < 50 | 1990 | DCHPS06490ES00_ |
| | 580 " | 116 x 185 | 80 | 1.4 | < 50 | 2330 | DCHPS06580ET00_ |
| | 710 " | 116 x 215 | 90 | 1.3 | < 50 | 2710 | DCHPS06710EU00_ |
| | 780 " | 116 x 230 | 90 | 1.2 | < 50 | 2900 | DCHPS06780EV00_ |
| | 890 " | 116 x 255 | 90 | 1.2 | < 50 | 3210 | DCHPS06890EW00_ |
| | 960 " | 116 x 295 | 90 | 1.1 | < 50 | 3720 | DCHPS06960EX00_ |
| 1170 " | 116 x 342 | 110 | 0.8 | < 50 | 4350 | DCHPS07117EX00_ | |

Contacts can handle: peak currents \hat{I} up to 10 kA
surge currents I_S up to 40 kA

Customer-specific capacitances or voltages on request

* General guide

female

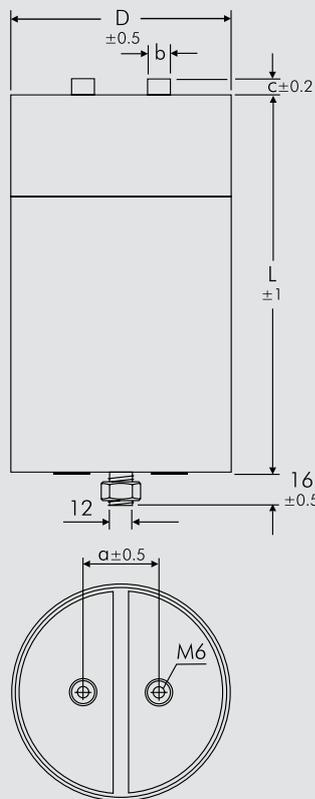

male

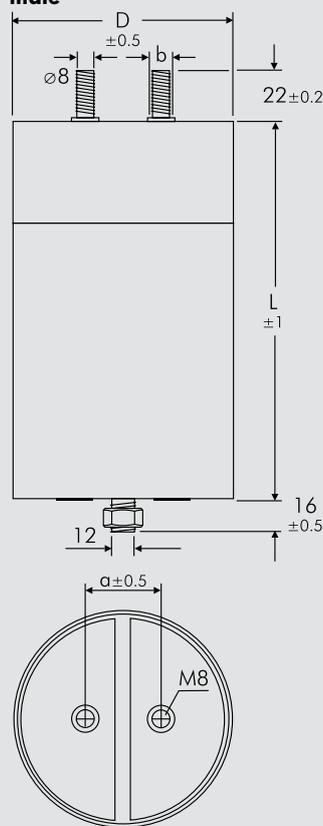

Part number completion:

Tolerance: 20 % = M

10 % = K

5 % = J

Packing: bulk = S

Connection: male = OM

female = OF

| D | L | a | b | c |
|-----|-----|----|----|---|
| 85 | 110 | 32 | 12 | 6 |
| 85 | 140 | 32 | 12 | 6 |
| 85 | 155 | 32 | 12 | 6 |
| 85 | 185 | 32 | 12 | 6 |
| 85 | 210 | 32 | 12 | 6 |
| 85 | 235 | 32 | 12 | 6 |
| 85 | 252 | 32 | 12 | 6 |
| 85 | 260 | 32 | 12 | 6 |
| 85 | 345 | 32 | 12 | 6 |
| 116 | 110 | 50 | 14 | 5 |
| 116 | 140 | 50 | 14 | 5 |
| 116 | 158 | 50 | 14 | 5 |
| 116 | 185 | 50 | 14 | 5 |
| 116 | 215 | 50 | 14 | 5 |
| 116 | 230 | 50 | 14 | 5 |
| 116 | 255 | 50 | 14 | 5 |
| 116 | 295 | 50 | 14 | 5 |
| 116 | 342 | 50 | 14 | 5 |

Dims. in mm.

Rights reserved to amend design data without prior notification.



WIMA Part Number System

A WIMA part number consists of 18 digits and is composed as follows:

- Field 1 - 4: Type description
- Field 5 - 6: Rated voltage
- Field 7 - 10: Capacitance
- Field 11 - 12: Size and PCM
- Field 13 - 14: Version code (e.g. Snubber versions)
- Field 15: Capacitance tolerance
- Field 16: Packing
- Field 17 - 18: Pin length (untaped)

| | | | | | | | | | | | | | | | | | |
|----------|----------|----------|----------|----------|----------|--------------|----------|----------|-------------|----------|----------|----------|----------|----------|----------|----------|----------|
| 1 | 2 | 3 | 4 | 5 | 6 | 7 | 8 | 9 | 10 | 11 | 12 | 13 | 14 | 15 | 16 | 17 | 18 |
| M | K | S | 2 | C | 0 | 2 | 1 | 0 | 0 | 1 | A | 0 | 0 | M | S | S | D |
| MKS 2 | | | | 63 VDC | | 0.01 μ F | | | 2.5x6.5x7.2 | | - | | 20% | bulk | 6-2 | | |

| | | | | | | | | | | | | | | | | | |
|--|--|---|--|--|--|--|--|--|--|--|--|--|--|--|--|--|--|
| <p>Type description:</p> <p>SMD-PET = SMDT SMD-PEN = SMDN SMD-PPS = SMDI FKP 02 = FKPO MKS 02 = MKS0 FKS 2 = FKS2 FKP 2 = FKP2 MKS 2 = MKS2 MKP 2 = MKP2 FKS 3 = FKS3 FKP 3 = FKP3 MKS 4 = MKS4 MKP 4 = MKP4 MKP 10 = MKP1 FKP 4 = FKP4 FKP 1 = FKP1 MKP-X2 = MKX2 MKP-X2 R = MKXR MKP-X1 R = MKX1 MKP-Y2 = MKY2 MP 3-X2 = MPX2 MP 3-X1 = MPX1 MP 3-Y2 = MPY2 MP 3R-Y2 = MPRY Snubber MKP = SNMP Snubber FKP = SNFP GTO MKP = GTOM DC-LINK MKP 3 = DCP3 DC-LINK MKP 4 = DCP4 DC-LINK MKP 4S = DCP4S DC-LINK MKP 5 = DCP5 DC-LINK MKP 6 = DCP6 DC-LINK HC = DCHC</p> | <p>Rated voltage:</p> <p>50 VDC = B0 63 VDC = C0 100 VDC = D0 250 VDC = F0 400 VDC = G0 450 VDC = H0 600 VDC = I0 630 VDC = J0 700 VDC = K0 800 VDC = L0 850 VDC = M0 900 VDC = N0 1000 VDC = O1 1100 VDC = P0 1200 VDC = Q0 1250 VDC = R0 1500 VDC = S0 1600 VDC = T0 2000 VDC = U0 2500 VDC = V0 3000 VDC = W0 4000 VDC = X0 6000 VDC = Y0 250 VAC = 0W 275 VAC = 1W 300 VAC = 2W 305 VAC = AW 400 VAC = 3W 440 VAC = 4W 500 VAC = 5W ...</p> | <p>Capacitance:</p> <p>22 pF = 0022 47 pF = 0047 100 pF = 0100 150 pF = 0150 220 pF = 0220 330 pF = 0330 470 pF = 0470 680 pF = 0680 1000 pF = 1100 1500 pF = 1150 2200 pF = 1220 3300 pF = 1330 4700 pF = 1470 6800 pF = 1680 0.01 μF = 2100 0.022 μF = 2220 0.047 μF = 2470 0.1 μF = 3100 0.22 μF = 3220 0.47 μF = 3470 1 μF = 4100 2.2 μF = 4220 4.7 μF = 4470 10 μF = 5100 22 μF = 5220 47 μF = 5470 100 μF = 6100 220 μF = 6220 1000 μF = 7100 1500 μF = 7150 ...</p> | <p>Size:</p> <p>4.8x3.3x3 Size 1812 = KA 4.8x3.3x4 Size 1812 = KB 5.7x5.1x3.5 Size 2220 = QA 5.7x5.1x4.5 Size 2220 = QB 7.2x6.1x3 Size 2824 = TA 7.2x6.1x5 Size 2824 = TB 10.2x7.6x5 Size 4030 = VA 12.7x10.2x6 Size 5040 = XA 15.3x13.7x7 Size 6054 = YA 2.5x7x4.6 PCM 2.5 = 0B 3x7.5x4.6 PCM 2.5 = 0C 2.5x6.5x7.2 PCM 5 = 1A 3x7.5x7.2 PCM 5 = 1B 2.5x7x10 PCM 7.5 = 2A 3x8.5x10 PCM 7.5 = 2B 3x9x13 PCM 10 = 3A 4x9x13 PCM 10 = 3C 5x11x18 PCM 15 = 4B 6x12.5x18 PCM 15 = 4C 5x14x26.5 PCM 22.5 = 5A 6x15x26.5 PCM 22.5 = 5B 9x19x31.5 PCM 27.5 = 6A 11x21x31.5 PCM 27.5 = 6B 9x19x41.5 PCM 37.5 = 7A 11x22x41.5 PCM 37.5 = 7B 19x31x56 PCM 48.5 = 8D 35x50x57 PCM 52.5 = 9F ...</p> | <p>Tolerance:</p> <p>\pm20% = M \pm10% = K \pm5% = J \pm2.5% = H \pm1% = E ...</p> <p>Packing:</p> <p>AMMO H16.5 340x340 = A AMMO H16.5 490x370 = B AMMO H18.5 340x340 = C AMMO H18.5 490x370 = D REEL H16.5 360 = F REEL H16.5 500 = H REEL H18.5 360 = I REEL H18.5 500 = J ROLL H16.5 = N ROLL H18.5 = O BLISTER W12 180 = P BLISTER W12 330 = Q BLISTER W16 330 = R BLISTER W24 330 = T Bulk/TPS Standard = S ...</p> | | | | | | | | | | | | | |
| | | | | | | | | | | | | | | | | | |

| | |
|--|---|
| <p>Version code:</p> <p>Standard = 00 Version A1 = 1A Version A1.1.1 = 1B Version A2 = 2A ...</p> | <p>Pin length (untaped)</p> <p>3.5 \pm0.5 = C9 6-2 = SD 16 \pm1 = P1 ...</p> |
|--|---|

The data on this page is not complete and serves only to explain the part number system. Part number information is listed on the pages of the respective WIMA range.



Компания «ЭлектроПласт» предлагает заключение долгосрочных отношений при поставках импортных электронных компонентов на взаимовыгодных условиях!

Наши преимущества:

- Оперативные поставки широкого спектра электронных компонентов отечественного и импортного производства напрямую от производителей и с крупнейших мировых складов;
- Поставка более 17-ти миллионов наименований электронных компонентов;
- Поставка сложных, дефицитных, либо снятых с производства позиций;
- Оперативные сроки поставки под заказ (от 5 рабочих дней);
- Экспресс доставка в любую точку России;
- Техническая поддержка проекта, помощь в подборе аналогов, поставка прототипов;
- Система менеджмента качества сертифицирована по Международному стандарту ISO 9001;
- Лицензия ФСБ на осуществление работ с использованием сведений, составляющих государственную тайну;
- Поставка специализированных компонентов (Xilinx, Altera, Analog Devices, Intersil, Interpoint, Microsemi, Aeroflex, Peregrine, Syfer, Eurofarad, Texas Instrument, Miteq, Cobham, E2V, MA-COM, Hittite, Mini-Circuits, General Dynamics и др.);

Помимо этого, одним из направлений компании «ЭлектроПласт» является направление «Источники питания». Мы предлагаем Вам помощь Конструкторского отдела:

- Подбор оптимального решения, техническое обоснование при выборе компонента;
- Подбор аналогов;
- Консультации по применению компонента;
- Поставка образцов и прототипов;
- Техническая поддержка проекта;
- Защита от снятия компонента с производства.



Как с нами связаться

Телефон: 8 (812) 309 58 32 (многоканальный)

Факс: 8 (812) 320-02-42

Электронная почта: org@eplast1.ru

Адрес: 198099, г. Санкт-Петербург, ул. Калинина, дом 2, корпус 4, литера А.