

## 3K3A1 SERIES 1

### Thermistor

#### SPECIFICATIONS

- **Thermally conductive epoxy coating**
- **Ø 2.4 mm Maximum Diameter**
- **32 AWG Alloy 180 Leads**
- **Choice of 4 temperature tolerance classifications**
- **RoHS Compliant**

The BetaCURVE Chip is Soldered to 32 AWG Alloy 180 Leads and Encapsulated in Stycast Epoxy Resin

**FEATURES**

- Interchangeability
- Proven Stability and Reliability
- Rapid time response
- Alloy lead wires for reduced thermal conductivity ("stem effect")
- Thermally Conductive Epoxy Coating
- Temperature range -40 °C to +125°C

**APPLICATIONS**

- Temperature sensing, control and compensation
- Tight Tolerance Instrumentation
- Assembly into probes for a wide variety of applications
- General Instrumentation applications

**PERFORMANCE SPECS**

Parameters	Units	Value
Resistance @ +25°C	Ohms	3,000
3K3A1A Resistance tolerance from 0°C to +70°C	°C	0.1
3K3A1B Resistance tolerance from 0°C to +70°C	°C	0.2
3K3A1C Resistance tolerance from 0°C to +70°C	°C	0.5
3K3A1D Resistance tolerance from 0°C to +70°C	°C	1.0
Alpha Value @ 25°C	%/°C	4.39
Beta Value 25/85	K	3976
Tolerance on Beta Value 25/85	%	0.5
Time response in Liquids	Seconds	<1
Dissipation Constant in still air	mW/°C	0.75

**MECHANICAL DETAILS**

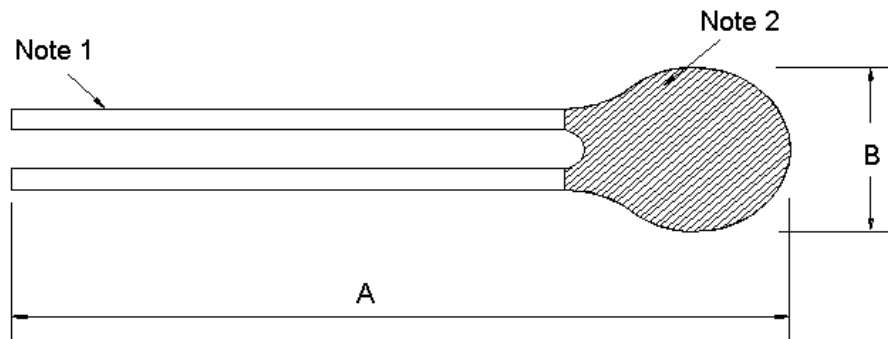

	Dimensions	
	A	B
	76 ± 2mm	2.4mm Max
<b>Note 1</b>	32 AWG Solid Alloy 180 Leads	
<b>Note 2</b>	Red Stycast 2850ft Epoxy	

**RESISTANCE V TEMPERATURE TABLE**

Temp. °C	Ohms
-40	100619
-39	94180
-38	88194
-37	82625
-36	77442
-35	72616
-34	68121
-33	63932
-32	60026
-31	56382
-30	52982
-29	49808
-28	46843
-27	44073
-26	41484
-25	39062
-24	36796
-23	34676
-22	32690
-21	30830
-20	29087
-19	27453
-18	25921
-17	24483
-16	23134
-15	21867
-14	20676
-13	19558
-12	18507
-11	17518
-10	16588
-9	15713
-8	14890
-7	14114
-6	13383
-5	12694
-4	12045
-3	11433
-2	10855
-1	10310
0	9795

Temp. °C	Ohms
1	9309
2	8850
3	8416
4	8006
5	7619
6	7252
7	6905
8	6577
9	6266
10	5971
11	5692
12	5428
13	5177
14	4940
15	4714
16	4500
17	4297
18	4105
19	3922
20	3748
21	3583
22	3426
23	3277
24	3135
25	<b>3000</b>
26	2872
27	2749
28	2633
29	2522
30	2417
31	2316
32	2220
33	2129
34	2042
35	1959
36	1880
37	1804
38	1732
39	1663
40	1597
41	1535

Temp. °C	Ohms
42	1475
43	1417
44	1362
45	1310
46	1260
47	1212
48	1166
49	1122
50	1080
51	1040
52	1002
53	965
54	929
55	895
56	863
57	832
58	802
59	774
60	746
61	720
62	695
63	670
64	647
65	625
66	603
67	583
68	563
69	544
70	525
71	508
72	491
73	475
74	459
75	444
76	430
77	416
78	402
79	389
80	377
81	365
82	353
83	342

Temp. °C	Ohms
84	332
85	321
86	311
87	302
88	292
89	283
90	275
91	267
92	259
93	251
94	243
95	236
96	229
97	222
98	216
99	210
100	204
101	198
102	192
103	187
104	181
105	176
106	171
107	167
108	162
109	157
110	153
111	149
112	145
113	141
114	137
115	133
116	130
117	126
118	123
119	120
120	117
121	114
122	111
123	108
124	105
125	102

## 3K3A1 SERIES 1

Thermistor

### ORDERING INFORMATION

Part Number	Description	$\Omega$ @25°C	MOQ
3K3A1A	Series 1 Thermistor	3,000	1,000*
3K3A1B	Series 1 Thermistor	3,000	1,000*
3K3A1C	Series 1 Thermistor	3,000	1,000*
3K3A1D	Series 1 Thermistor	3,000	1,000*

\* For quantities less than Minimum Order Quantity – Contact Distribution

#### NORTH AMERICA

Measurement Specialties, Inc.,  
a TE Connectivity Company  
910 Turnpike Road  
Shrewsbury, MA 01545  
Tel: 1-508-842-0516  
Fax: 1-508-842-0342  
Sales email:  
temperature.sales.amer@meas-spec.com

#### EUROPE

Measurement Specialties (Europe), Ltd.,  
a TE Connectivity Company  
Ballybrit Business Park  
Galway Ireland  
Tel: +353-91-753238  
Fax: +353-91-770789  
Sales email:  
temperature.sales.emea@meas-spec.com

#### ASIA

Measurement Specialties (China), Ltd.,  
a TE Connectivity Company  
No. 26 Langshan Road  
Shenzhen High-Tech Park (North)  
Nanshan District, Shenzhen 518057  
China  
Sales email:  
temperature.sales.asia@meas-spec.com

#### [TE.com/sensorsolutions](http://TE.com/sensorsolutions)

Measurement Specialties, Inc., a TE Connectivity company.

Measurement Specialties, TE Connectivity, TE Connectivity (logo) and EVERY CONNECTION COUNTS are trademarks. All other logos, products and/or company names referred to herein might be trademarks of their respective owners.

The information given herein, including drawings, illustrations and schematics which are intended for illustration purposes only, is believed to be reliable. However, TE Connectivity makes no warranties as to its accuracy or completeness and disclaims any liability in connection with its use. TE Connectivity's obligations shall only be as set forth in TE Connectivity's Standard Terms and Conditions of Sale for this product and in no case will TE Connectivity be liable for any incidental, indirect or consequential damages arising out of the sale, resale, use or misuse of the product. Users of TE Connectivity products should make their own evaluation to determine the suitability of each such product for the specific application.

© 2015 TE Connectivity Ltd. family of companies All Rights Reserved.



Компания «ЭлектроПласт» предлагает заключение долгосрочных отношений при поставках импортных электронных компонентов на взаимовыгодных условиях!

Наши преимущества:

- Оперативные поставки широкого спектра электронных компонентов отечественного и импортного производства напрямую от производителей и с крупнейших мировых складов;
- Поставка более 17-ти миллионов наименований электронных компонентов;
- Поставка сложных, дефицитных, либо снятых с производства позиций;
- Оперативные сроки поставки под заказ (от 5 рабочих дней);
- Экспресс доставка в любую точку России;
- Техническая поддержка проекта, помощь в подборе аналогов, поставка прототипов;
- Система менеджмента качества сертифицирована по Международному стандарту ISO 9001;
- Лицензия ФСБ на осуществление работ с использованием сведений, составляющих государственную тайну;
- Поставка специализированных компонентов (Xilinx, Altera, Analog Devices, Intersil, Interpoint, Microsemi, Aeroflex, Peregrine, Syfer, Eurofarad, Texas Instrument, Miteq, Cobham, E2V, MA-COM, Hittite, Mini-Circuits, General Dynamics и др.);

Помимо этого, одним из направлений компании «ЭлектроПласт» является направление «Источники питания». Мы предлагаем Вам помощь Конструкторского отдела:

- Подбор оптимального решения, техническое обоснование при выборе компонента;
- Подбор аналогов;
- Консультации по применению компонента;
- Поставка образцов и прототипов;
- Техническая поддержка проекта;
- Защита от снятия компонента с производства.



#### Как с нами связаться

**Телефон:** 8 (812) 309 58 32 (многоканальный)

**Факс:** 8 (812) 320-02-42

**Электронная почта:** [org@eplast1.ru](mailto:org@eplast1.ru)

**Адрес:** 198099, г. Санкт-Петербург, ул. Калинина, дом 2, корпус 4, литера А.