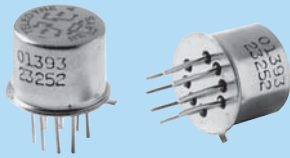




A Unit of Teledyne Electronics and Communications

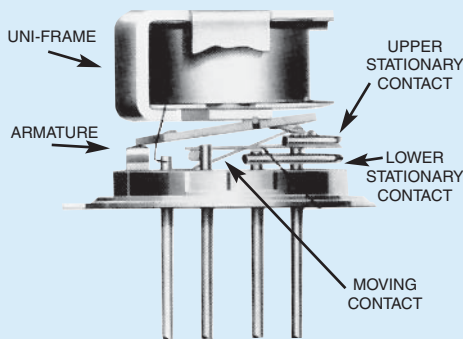
**SERIES  
412**

**ESTABLISHED RELIABILITY  
TO-5 RELAYS  
DPDT**



| SERIES DESIGNATION | RELAY TYPE  |
|--------------------|---|
| 412                | DPDT basic relay  |
| 412D               | DPDT relay with internal diode for coil suppression   |
| 412DD              | DPDT relay with internal diodes for coil transient suppression and polarity reversal protection |
| 412T               | DPDT relay with internal transistor driver and coil transient suppression diode                 |

**INTERNAL CONSTRUCTION**



**DESCRIPTION**

The TO-5 relay, originally conceived and developed by Teledyne, has become one of the industry standards for low-level switching from dry circuit to 1 ampere. Designed expressly for high-density PC board mounting, its small size and low coil power dissipation make the 412 relay one of the most versatile ultraminiature relays available.

The following unique construction features and manufacturing techniques provide excellent resistance to environmental extremes and overall high reliability.

- All welded construction.
- Unique uni-frame design, providing high magnetic efficiency and mechanical rigidity.
- High force/mass ratios for resistance to shock and vibration.
- Advanced cleaning techniques provide maximum assurance of internal cleanliness.
- Precious metal alloy contact material with gold plating assures excellent high current and dry circuit switching capabilities.

The Series 412D and 412DD relays have internal discrete silicon diodes for coil suppression and polarity reversal protection. The hybrid 412T relay features an internal silicon suppression diode and transistor driver. This hybrid package reduces required PC board floor space by reducing the number of external components needed to drive the relay.

By virtue of its inherently low intercontact capacitance and contact circuit losses, the 412 relay has proven to be an excellent ultraminiature RF switch for frequency ranges well into the UHF spectrum. A typical RF application for the TO-5 relay is in handheld radio transceivers, wherein the combined features of good RF performance, small size, low coil power dissipation and high reliability make it a preferred method of T-R switching (see Figure 1).

**ENVIRONMENTAL AND PHYSICAL SPECIFICATIONS**

|                                      |                              |
|--------------------------------------|------------------------------|
| <b>Temperature</b><br>(Ambient)      | -65°C to +125°C              |
| <b>Vibration</b><br>(General Note 1) | 30 g's to 3000 Hz            |
| <b>Shock</b><br>(General Note 1)     | 75 g's,<br>6 msec, half-sine |
| <b>Acceleration</b>                  | 50 g's                       |
| <b>Enclosure</b>                     | Hermetically sealed          |
| <b>Weight</b>                        | 0.09 oz. (2.55g) max.        |

**SERIES 412**

**GENERAL ELECTRICAL SPECIFICATIONS (-65°C to +125°C unless otherwise noted) (Notes 2 & 3)**

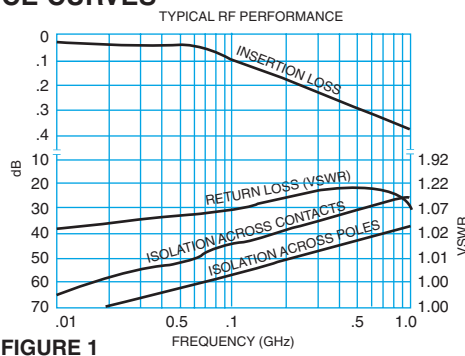
|   |  |                           |
|---|--|---------------------------|
| <b>Contact Arrangement</b>  | 2 Form C (DPDT)  |                           |
| <b>Rated Duty</b>   | Continuous   |                           |
| <b>Contact Resistance</b>   | 0.1 ohm max. before life; 0.2 ohm max. after life at 1A/28Vdc (measured 1/8" from header)  |                           |
| <b>Contact Load Ratings (DC)</b><br>(See Fig. 2 for other DC resistive voltage/current ratings) | Resistive: 1 Amp/28Vdc<br>Inductive: 200 mA/28Vdc (320 mH)<br>Lamp: 100 mA/28Vdc<br>Low Level: 10 to 50 µA/10 to 50mV                                    |                           |
| <b>Contact Load Ratings (AC)</b>  | Resistive: 250 mA/115Vac, 60 and 400 Hz (Case not grounded)<br>100 mA/115Vac, 60 and 400 Hz (Case grounded)  |                           |
| <b>Contact Life Ratings</b>   | 10,000,000 cycles (typical) at low level<br>1,000,000 cycles (typical) at 0.5A/28Vdc resistive<br>100,000 cycles min. at all other loads specified above |                           |
| <b>Contact Overload Rating</b>  | 2A/28Vdc Resistive (100 cycles min.)   |                           |
| <b>Contact Carry Rating</b>   | Contact factory  |                           |
| <b>Coil Operating Power</b>   | 450 milliwatts typical at nominal rated voltage @ 25°C   |                           |
| <b>Operate Time</b>   | 2.0 msec max. at nominal rated coil voltage  |                           |
| <b>Release Time</b>   | 412 Series: 1.5 msec max. 412D, 412DD Series: 4.0 msec max. 412T Series: 7.5 msec max.   |                           |
| <b>Contact Bounce</b>   | 1.5 msec max.  |                           |
| <b>Intercontact Capacitance</b>   | 0.4 pf typical   |                           |
| <b>Insulation Resistance</b>  | 10,000 megohms min. between mutually isolated terminals  |                           |
| <b>Dielectric Strength</b>  | Atmospheric pressure: 500 Vrms/60Hz  | 70,000 ft.: 125 Vrms/60Hz |
| <b>Negative Coil Transient (Vdc)</b>  | 412D, 412DD, 412T  | 1.0 max                   |
| <b>Diode P.I.V. (Vdc)</b>   | 412D, 412DD, 412T  | 100 min.                  |
| <b>412T Transistor Characteristics</b>  | <b>Base Turn Off Voltage (Vdc)</b>   | 0.3 min.                  |
|   | <b>Emitter-base breakdown Voltage (BV<sub>EB0</sub>) (@25°C) (Vdc)</b>   | 6.0 min.                  |
|   | <b>Collector-base breakdown Voltage (BV<sub>CB0</sub>) (@25°C &amp; I<sub>c</sub> = 100 µA) (Vdc)</b>  | 75 min.                   |

ESTABLISHED RELIABILITY

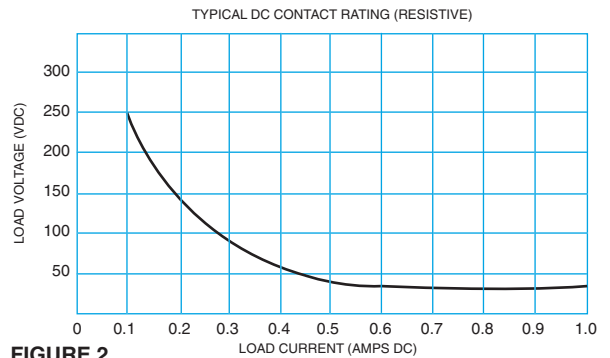
**DETAILED ELECTRICAL SPECIFICATIONS (-65°C to +125°C unless otherwise noted) (Note 3)**

| BASE PART NUMBERS<br>(See Note 10 for full P/N example)            | ➔                        | 412-5                       | 412-6                       | 412-9                       | 412-12                         | 412-18                         | 412-26                         |      |
|--|--------------------------|-----------------------------|-----------------------------|-----------------------------|--------------------------------|--------------------------------|--------------------------------|------|
|  |                          | 412D-5<br>412DD-5<br>412T-5 | 412D-6<br>412DD-6<br>412T-6 | 412D-9<br>412DD-9<br>412T-9 | 412D-12<br>412DD-12<br>412T-12 | 412D-18<br>412DD-18<br>412T-18 | 412D-26<br>412DD-26<br>412T-26 |      |
| <b>Coil Voltage (Vdc)</b>  | Nom.                     | 5.0                         | 6.0                         | 9.0                         | 12.0                           | 18.0                           | 26.5                           |      |
|  | Max.                     | 5.8                         | 8.0                         | 12.0                        | 16.0                           | 24.0                           | 32.0                           |      |
| <b>Coil Resistance (Ohms ±10% @25°C)</b>                           | 412, 412D, 412T (Note 4) | 50                          | 98                          | 220                         | 390                            | 880                            | 1560                           |      |
|  | 412DD (Note 4)           | 39                          | 78                          | 220                         | 390                            | 880                            | 1560                           |      |
| <b>Coil Current (mAdc @25°C) (412DD Series)</b>                    | Min.                     | 93.2                        | 58.3                        | 33.0                        | 25.6                           | 17.5                           | 14.8                           |      |
|  | Max.                     | 128.2                       | 78.3                        | 42.9                        | 32.8                           | 22.1                           | 18.5                           |      |
| <b>Coil Current (mAdc @25°C) (412T Series)</b>                     | (Note 7) Min.            | 82.2                        | 52.9                        | 35.3                        | 26.6                           | 17.9                           | 14.7                           |      |
|  | Max.                     | 112.1                       | 69.9                        | 47.4                        | 35.8                           | 24.0                           | 19.8                           |      |
| <b>Pick-up Voltage (Vdc, Max.)</b>                                 | 412, 412D                | 3.5                         | 4.5                         | 6.8                         | 9.0                            | 13.5                           | 18.0                           |      |
|  | 412DD                    | 3.9                         | 5.2                         | 7.8                         | 10.0                           | 14.5                           | 19.0                           |      |
|  | 412T (Note 7)            | 3.5                         | 4.5                         | 6.8                         | 9.0                            | 13.5                           | 18.0                           |      |
| <b>Base Current to Turn On (mAdc, Max.) (412T Series) (Note 7)</b> |                          | 3.00                        | 2.04                        | 1.36                        | 1.03                           | 0.68                           | 0.50                           |      |
| <b>Drop-out Voltage (Vdc)</b>                                      | 412, 412D, 412T          | Min.                        | 0.14                        | 0.18                        | 0.35                           | 0.41                           | 0.59                           | 0.89 |
|  |                          | Max.                        | 2.3                         | 3.2                         | 4.9                            | 6.5                            | 10.0                           | 13.0 |
|  | 412DD                    | Min.                        | 0.6                         | 0.7                         | 0.8                            | 0.9                            | 1.1                            | 1.4  |
|  |                          | Max.                        | 2.8                         | 3.4                         | 5.3                            | 6.5                            | 10.0                           | 13.0 |

**PERFORMANCE CURVES (NOTE 2)**

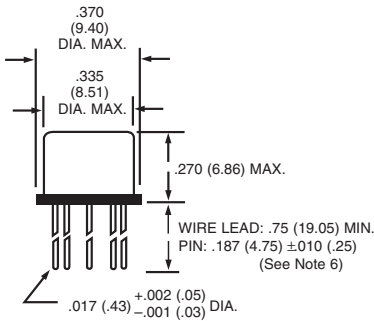


**FIGURE 1**

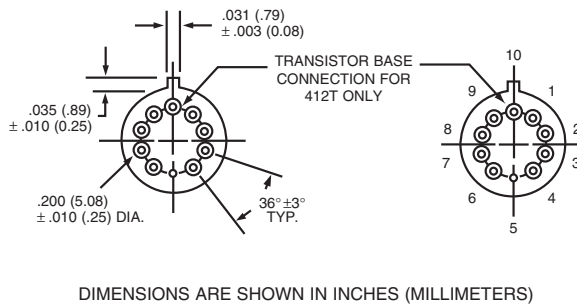


**FIGURE 2**

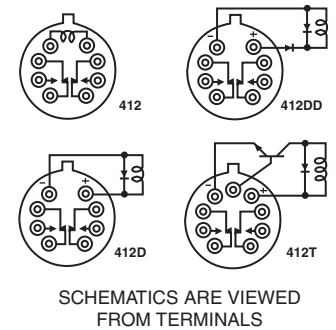
**OUTLINE DIMENSIONS**



**TERMINAL LOCATIONS AND PIN NUMBERING (REF. ONLY)**  
 (Viewed from Terminals)



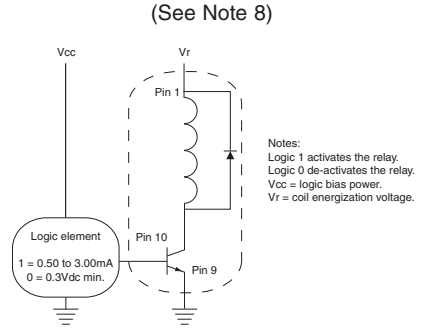
**SCHEMATIC DIAGRAMS**



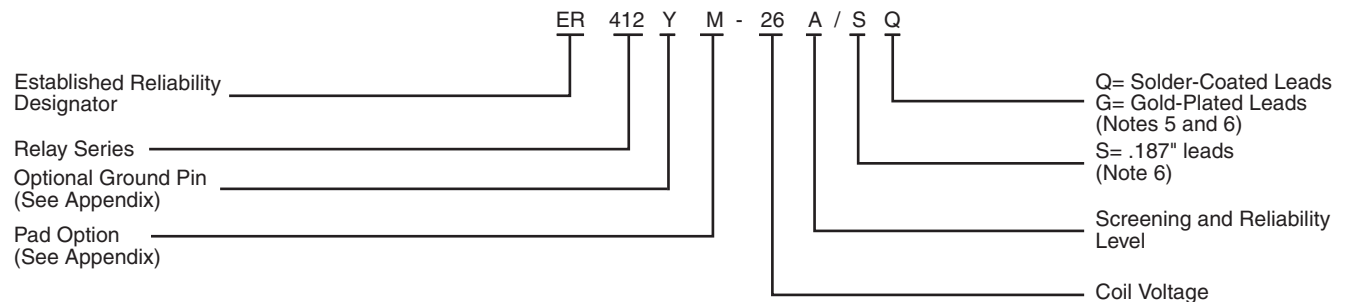
**GENERAL NOTES**

- Relay contacts will exhibit no chatter in excess of 10 µsec or transfer in excess of 1 µsec.
- "Typical" characteristics are based on available data and are best estimates. No on-going verification tests are performed.
- Unless otherwise specified, parameters are initial values.
- For reference only. Coil resistance not directly measurable at relay terminals due to internal series semiconductor. 412DD and 412T only.
- Unless otherwise specified, relays will be supplied with either gold-plated or solder-coated leads.
- The slash and characters appearing after the slash are not marked on the relay.
- Limit Base Emitter current to 15 mA.
- Applicable to all coil voltages. See Base current to turn on.
- Screened HI-REL versions available. Contact factory.
- 

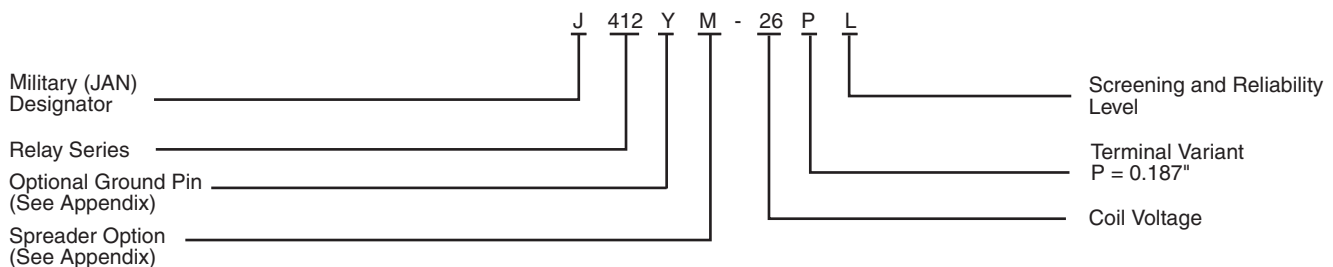
**TYPICAL LOGIC INTERFACE**



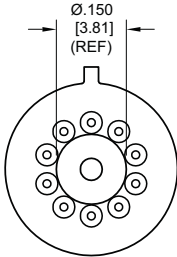
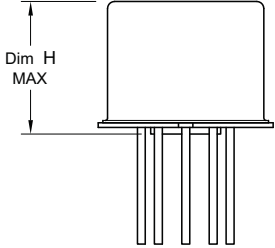
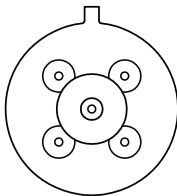
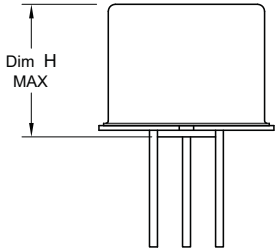
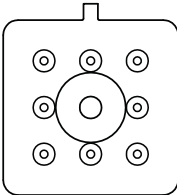
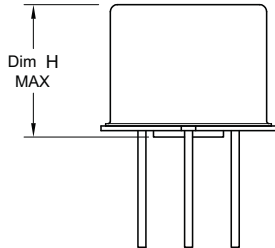
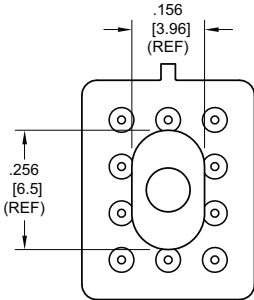
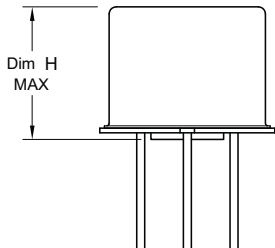
Teledyne Part Numbering System for T<sup>2</sup>R<sup>®</sup> Established Reliability Relay



Teledyne Part Numbering System for Military Qualified (JAN) Relays



# Appendix A: Spacer Pads

| Pad designation and bottom view dimensions   | Height  | For use with the following:  | Dim. H Max.  |
|--|---|--|--------------|
|  <p style="text-align: center;">“M4” Pad for TO-5</p>         |    | ER411T<br>ER412, ER412D, ER412DD   | .295 (7.49)  |
|  |   | 712, 712D, 712TN,<br>RF300, RF310, RF320   | .300 (7.62)  |
|  |   | ER420, ER422D, ER420DD, 421,<br>ER421D, ER421DD, ER422, ER422D,<br>ER422DD, 722, 722D, RF341 | .305 (7.75)  |
|  |   | ER431T, ER432T,<br>ER432, ER432D, ER432DD  | .400 (10.16) |
|  |   | 732, 732D, 732TN, RF303, RF313,<br>RF323   | .410 (10.41) |
|  |   | RF312  | .350 (8.89)  |
|  <p style="text-align: center;">“M4” Pad for TO-5</p>         |    | ER411, ER411D, ER411DD   | .295 (7.49)  |
|  |   | ER431, ER431D, ER431DD   | .400 (10.16) |
|  |   | RF311  | .300 (7.62)  |
|  |   | RF331  | .410 (10.41) |
|  <p style="text-align: center;">“M4” Pad for Centigrid®</p> |  | 172, 172D  | .305 (7.75)  |
|  |   | ER114, ER114D, ER114DD,<br>J114, J114D, J114DD   | .300 (7.62)  |
|  |   | ER134, ER134D, ER134DD,<br>J134, J134D, J134DD   | .400 (10.16) |
|  |   | RF100  | .315 (8.00)  |
|  |   | RF103  | .420 (10.67) |
|  <p style="text-align: center;">“M9” Pad for Centigrid®</p> |  | 122C, A152   | .320 (8.13)  |
|  |   | ER116C, J116C  | .300 (7.62)  |
|  |   | ER136C, J136C  | .400 (10.16) |
|  |   | RF180  | .325 (8.25)  |
|  |   | A150   | .305 (7.75)  |

**Notes:**

1. Spacer pad material: Polyester film.
2. To specify an “M4” or “M9” spacer pad, refer to the mounting variants portion of the part numbering example in the applicable datasheet.
3. Dimensions are in inches (mm).
4. Unless otherwise specified, tolerance is  $\pm .010$  (.25).
5. Add 10 m $\Omega$  to the contact resistance show in the datasheet.
6. Add 0.01 oz. (0.25 g) to the weight of the relay assembly shown in the datasheet.

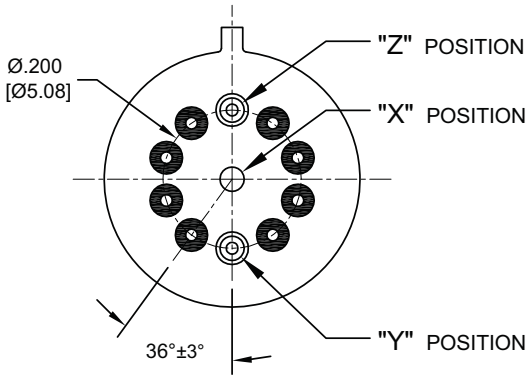
# Appendix A: Spreader Pads

| Pad designation and bottom view dimensions    | Height | For use with the following:   | Dim. H Max.  |
|---|--------|---|--------------|
| <p>“M” Pad <u>5/</u> <u>6/</u> <u>9/</u></p>  |        | ER411T, J411T, ER412, ER412D<br>ER412DD, J412, J412D, J412DD<br>ER412T, J412T                                       | .388 (9.86)  |
|   |        | 712, 712D, 712TN  | .393 (9.99)  |
|   |        | ER431T, J431T, ER432, ER432D<br>ER432DD, J432, J432D, J432DD<br>ER432T, J432T                                       | .493 (12.52) |
|   |        | 732, 732D, 732TN  | .503 (12.78) |
|   |        | ER420, J420, ER420D, J420D<br>ER420DD, J420DD, ER421, J421<br>ER421D, J421D, ER421DD<br>J422D, ER422DD, J422DD, 722 | .398 (10.11) |
| <p>“M2” Pad <u>7/</u> <u>8/</u></p>           |        | ER411T<br>ER412, ER412D, ER412DD<br>J412, J412D, J412DD   | .441 (11.20) |
|   |        | 712, 712D   | .451 (11.46) |
|   |        | ER421, ER421D, ER421DD<br>722, 732D   | .451 (11.46) |
|   |        | ER431T<br>ER432, ER432D, ER432DD  | .546 (13.87) |
|   |        | 732, 732D   | .556 (14.12) |
| <p>“M3” Pad <u>5/</u> <u>6/</u> <u>9/</u></p> |        | ER411, ER411D, ER411DD<br>ER411TX<br>ER412X, ER412DX, ER412DDX<br>ER412TX   | .388 (9.86)  |
|   |        | 712X, 712DX, 712TNX   | .393 (9.99)  |
|   |        | ER420X, ER420DX, ER420DDX<br>ER421X, ER421DX, ER421DDX<br>ER422X, ER422DX<br>ER422DDX, 722X, 722DDX                 | .398 (10.11) |
|   |        | ER431, ER431D, ER431DD<br>ER431TX<br>ER432X, ER432DX, ER432DDX<br>ER432TX   | .493 (12.52) |
|   |        | 732X, 732DX, 732TNX   | .503 (12.78) |

## Notes:

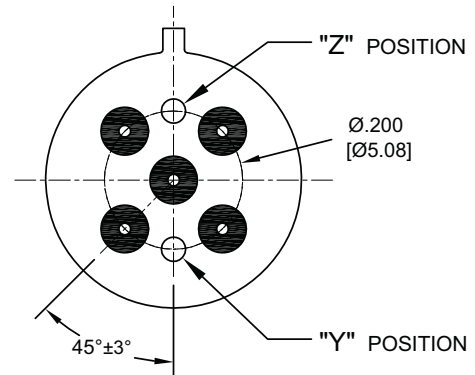
1. Spreader pad material: Diallyl Phthalate.
2. To specify an “M”, “M2” or “M3” spreader pad, refer to the mounting variants portion of the part number example in the applicable datasheet.
3. Dimensions are in inches (mm).
4. Unless otherwise specified, tolerance is  $\pm .010$ ” (0.25).
- 5/. Add 25 mΩ to the contact resistance shown in the datasheet.
- 6/. Add .01 oz. (0.25 g) to the weight of the relay assembly shown in the datasheet.
- 7/. Add 50 mΩ to the contact resistance shown in the datasheet.
- 8/. Add 0.025 oz (0.71 g) to the weight of the relay assembly shown in the datasheet.
- 9/. M3 pad to be used only when the relay has a center pin (e.g. ER411M3-12A, 722XM3-26.)

# Appendix A: Ground Pin Positions



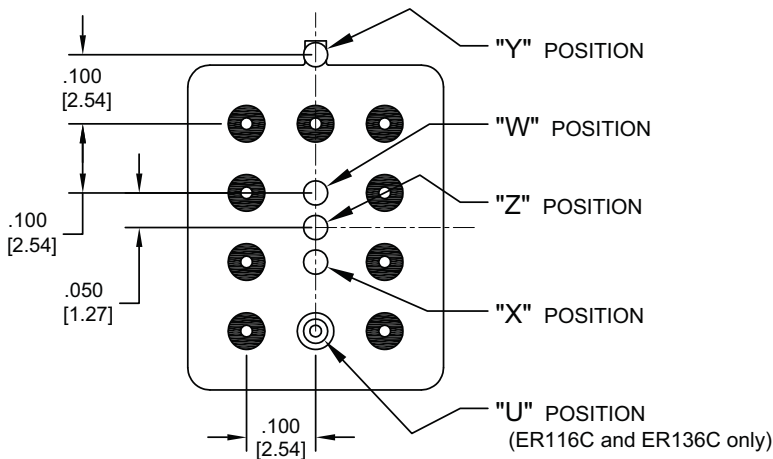
### TO-5 Relays:

ER411T, ER412, ER412T, ER420, ER421, ER422,  
ER431T, ER432, ER432T, 712, 712TN, 400H, 400K,  
400V, RF300, RF303, RF341, RF312, RF310, RF313,  
RF320, RF323



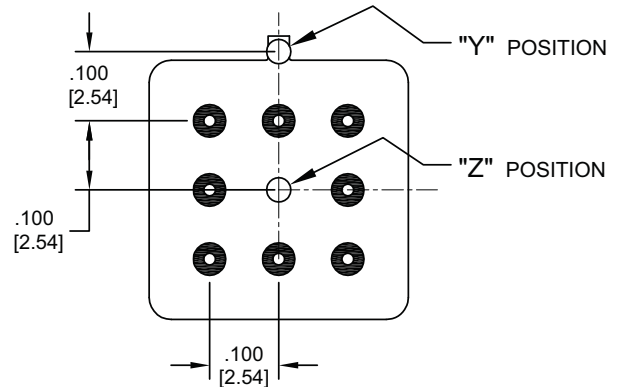
### TO-5 Relays:

ER411, ER431, RF311, RF331



### Centigrid® Relays:

RF180, ER116C, 122C, ER136C



### Centigrid® Relays:

RF100, RF103, ER114, ER134, 172

- Indicates ground pin position
- Indicates glass insulated lead position
- ◎ Indicates ground pin or lead position depending on relay type

### NOTES

1. Terminal views shown
2. Dimensions are in inches (mm)
3. Tolerances: ± .010 (±.25) unless otherwise specified
4. Ground pin positions are within .015 (0.38) dia. of true position
5. Ground pin head dia., 0.035 (0.89) ref: height 0.010 (0.25) ref.
6. Lead dia. 0.017 (0.43) nom.



Компания «ЭлектроПласт» предлагает заключение долгосрочных отношений при поставках импортных электронных компонентов на взаимовыгодных условиях!

Наши преимущества:

- Оперативные поставки широкого спектра электронных компонентов отечественного и импортного производства напрямую от производителей и с крупнейших мировых складов;
- Поставка более 17-ти миллионов наименований электронных компонентов;
- Поставка сложных, дефицитных, либо снятых с производства позиций;
- Оперативные сроки поставки под заказ (от 5 рабочих дней);
- Экспресс доставка в любую точку России;
- Техническая поддержка проекта, помощь в подборе аналогов, поставка прототипов;
- Система менеджмента качества сертифицирована по Международному стандарту ISO 9001;
- Лицензия ФСБ на осуществление работ с использованием сведений, составляющих государственную тайну;
- Поставка специализированных компонентов (Xilinx, Altera, Analog Devices, Intersil, Interpoint, Microsemi, Aeroflex, Peregrine, Syfer, Eurofarad, Texas Instrument, Miteq, Cobham, E2V, MA-COM, Hittite, Mini-Circuits, General Dynamics и др.);

Помимо этого, одним из направлений компании «ЭлектроПласт» является направление «Источники питания». Мы предлагаем Вам помощь Конструкторского отдела:

- Подбор оптимального решения, техническое обоснование при выборе компонента;
- Подбор аналогов;
- Консультации по применению компонента;
- Поставка образцов и прототипов;
- Техническая поддержка проекта;
- Защита от снятия компонента с производства.



#### Как с нами связаться

**Телефон:** 8 (812) 309 58 32 (многоканальный)

**Факс:** 8 (812) 320-02-42

**Электронная почта:** [org@eplast1.ru](mailto:org@eplast1.ru)

**Адрес:** 198099, г. Санкт-Петербург, ул. Калинина, дом 2, корпус 4, литера А.