

## Charge Pump DC-TO-DC Voltage Converter

### FEATURES

- Converts +5V Logic Supply to  $\pm 5V$  System
- Wide Input Voltage Range ..... 1.5V to 12V
- Efficient Voltage Conversion ..... 99.9%
- Excellent Power Efficiency ..... 98%
- Low Power Consumption .....  $80\mu A$  @  $V_{IN} = 5V$
- Low Cost and Easy to Use
  - Only Two External Capacitors Required
- RS-232 Negative Power Supply
- Available in 8-Pin Small Outline (SOIC) and 8-Pin Plastic DIP Packages
- Improved ESD Protection ..... Up to 10kV
- No External Diode Required for High Voltage Operation
- Frequency Boost Raises  $F_{OSC}$  to 45kHz

### GENERAL DESCRIPTION

The TC1044S is a pin-compatible upgrade to the Industry standard TC7660 charge pump voltage converter. It converts a +1.5V to +12V input to a corresponding -1.5V to -12V output using only two low cost capacitors, eliminating inductors and their associated cost, size and EMI. Added features include an extended supply range to 12V, and a frequency boost pin for higher operating frequency, allowing the use of smaller external capacitors.

The on-board oscillator operates at a nominal frequency of 10kHz. Frequency is increased to 45kHz when pin 1 is connected to  $V^+$ . Operation below 10kHz (for lower supply current applications) is possible by connecting an external capacitor from OSC to ground (with pin 1 open).

The TC1044S is available in both 8-pin DIP and 8-pin small outline (SOIC) packages in commercial and extended temperature ranges.

### PIN CONFIGURATION (DIP AND SOIC)

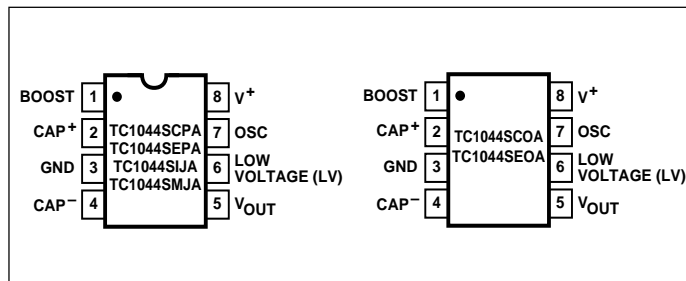

### ORDERING INFORMATION

Part No.	Package	Temp. Range
TC1044SCOA	8-Pin SOIC	0°C to +70°C
TC1044SCPA	8-Pin Plastic DIP	0°C to +70°C
TC1044SEOA	8-Pin SOIC	-40°C to +85°C
TC1044SEPA	8-Pin Plastic DIP	-40°C to +85°C
TC1044SIJA	8-Pin CerDIP	-25°C to +85°C
TC1044SMJA	8-Pin CerDIP	-55°C to +125°C
<b>TC7660EV</b>	<b>Charge Pump Family Evaluation Kit</b>	

### FUNCTIONAL BLOCK DIAGRAM

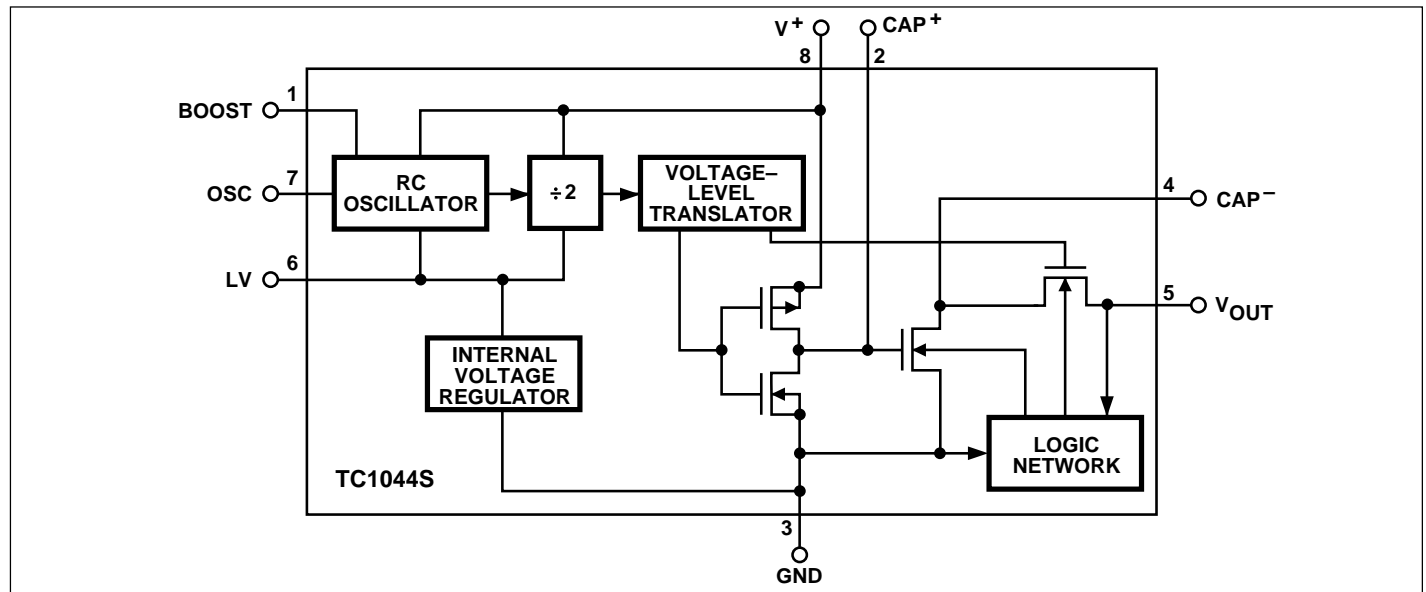

# Charge Pump DC-TO-DC Voltage Converter

## TC1044S

### ABSOLUTE MAXIMUM RATINGS\*

Supply Voltage .....	+13V
LV, Boost and OSC Inputs Voltage (Note 1) .....	- 0.3V to (V <sup>+</sup> + 0.3V) for V <sup>+</sup> < 5.5V (V <sup>+</sup> - 5.5V) to (V <sup>+</sup> + 0.3V) for V <sup>+</sup> > 5.5V
Current Into LV (Note 1) .....	20μA for V <sup>+</sup> > 3.5V
Output Short Duration (V <sub>SUPPLY</sub> ≤ 5.5V) .....	Continuous
Lead Temperature (Soldering, 10 sec) .....	+300°C

### Package Power Dissipation (T<sub>A</sub> ≤ 70°C) (Note 2)

8-Pin CerDIP .....	800mW
8-Pin Plastic DIP .....	730mW
8-Pin SOIC .....	470mW

### Operating Temperature Range

C Suffix .....	0°C to +70°C
I Suffix .....	- 25°C to +85°C
E Suffix .....	- 40°C to +85°C
M Suffix .....	- 55°C to +125°C
Storage Temperature Range .....	- 65°C to +150°C

\*Static-sensitive device. Unused devices must be stored in conductive material. Protect devices from static discharge and static fields. Stresses above those listed under "Absolute Maximum Ratings" may cause permanent damage to the device. These are stress ratings only and functional operation of the device at these or any other conditions above those indicated in the operation sections of the specifications is not implied. Exposure to absolute maximum rating conditions for extended periods may affect device reliability.

### ELECTRICAL CHARACTERISTICS: T<sub>A</sub> = +25°C, V<sup>+</sup> = 5V, C<sub>OSC</sub> = 0, Test Circuit (Figure 1), unless otherwise indicated.

Symbol	Parameter	Test Conditions	Min	Typ	Max	Unit
I <sup>+</sup>	Supply Current	R <sub>L</sub> = ∞ 0°C < T <sub>A</sub> < +70°C - 40°C < T <sub>A</sub> < +85°C - 55°C < T <sub>A</sub> < +125°C	—	80	160	μA
I <sup>+</sup>	Supply Current (Boost Pin = V <sup>+</sup> )	0°C < T <sub>A</sub> < +70°C - 40°C < T <sub>A</sub> < +85°C - 55°C < T <sub>A</sub> < +125°C	—	—	300	μA
V <sub>H2</sub> <sup>+</sup>	Supply Voltage Range, High	Min ≤ T <sub>A</sub> ≤ Max, R <sub>L</sub> = 10 kΩ, LV Open	3	—	12	V
V <sub>L2</sub> <sup>+</sup>	Supply Voltage Range, Low	Min ≤ T <sub>A</sub> ≤ Max, R <sub>L</sub> = 10 kΩ, LV to GND	1.5	—	3.5	V
R <sub>OUT</sub>	Output Source Resistance	I <sub>OUT</sub> = 20mA I <sub>OUT</sub> = 20mA, 0°C ≤ T <sub>A</sub> ≤ +70°C I <sub>OUT</sub> = 20mA, -40°C ≤ T <sub>A</sub> ≤ +85°C I <sub>OUT</sub> = 20mA, -55°C ≤ T <sub>A</sub> ≤ +125°C	—	60	100	Ω
		V <sup>+</sup> = 2V, I <sub>OUT</sub> = 3 mA, LV to GND 0°C ≤ T <sub>A</sub> ≤ +70°C - 55°C ≤ T <sub>A</sub> ≤ +125°C	—	—	250	Ω
F <sub>OSC</sub>	Oscillator Frequency	Pin 7 open; Pin 1 open or GND Boost Pin = V <sup>+</sup>	—	10	—	kHz
P <sub>EFF</sub>	Power Efficiency	R <sub>L</sub> = 5 kΩ; Boost Pin Open T <sub>MIN</sub> < T <sub>A</sub> < T <sub>MAX</sub> ; Boost Pin Open Boost Pin = V <sup>+</sup>	96	98	—	%
			95	97	—	
			—	88	—	
V <sub>OUT EFF</sub>	Voltage Conversion Efficiency	R <sub>L</sub> = ∞	99	99.9	—	%
Z <sub>OSC</sub>	Oscillator Impedance	V <sup>+</sup> = 2V	—	1	—	MΩ
		V <sup>+</sup> = 5V	—	100	—	kΩ

- NOTES:**
1. Connecting any input terminal to voltages greater than V<sup>+</sup> or less than GND may cause destructive latch-up. It is recommended that no inputs from sources operating from external supplies be applied prior to "power up" of the TC1044S.
  2. Derate linearly above 50°C by 5.5mW/°C.

### Circuit Description

The TC1044S contains all the necessary circuitry to implement a voltage inverter, with the exception of two external capacitors, which may be inexpensive 10  $\mu\text{F}$  polarized electrolytic capacitors. Operation is best understood by considering Figure 2, which shows an idealized voltage inverter. Capacitor  $C_1$  is charged to a voltage,  $V^+$ , for the half cycle when switches  $S_1$  and  $S_3$  are closed. (**Note:** Switches  $S_2$  and  $S_4$  are open during this half cycle.) During the second half cycle of operation, switches  $S_2$  and  $S_4$  are closed, with  $S_1$  and  $S_3$  open, thereby shifting capacitor  $C_1$  negatively by  $V^+$  volts. Charge is then transferred from  $C_1$  to  $C_2$ , such that the voltage on  $C_2$  is exactly  $V^+$ , assuming ideal switches and no load on  $C_2$ .

The four switches in Figure 2 are MOS power switches;  $S_1$  is a P-channel device, and  $S_2$ ,  $S_3$  and  $S_4$  are N-channel devices. The main difficulty with this approach is that in integrating the switches, the substrates of  $S_3$  and  $S_4$  must always remain reverse-biased with respect to their sources, but not so much as to degrade their ON resistances. In addition, at circuit start-up, and under output short circuit conditions ( $V_{\text{OUT}} = V^+$ ), the output voltage must be sensed and the substrate bias adjusted accordingly. Failure to accomplish this will result in high power losses and probable device latch-up.

This problem is eliminated in the TC1044S by a logic network which senses the output voltage ( $V_{\text{OUT}}$ ) together with the level translators, and switches the substrates of  $S_3$  and  $S_4$  to the correct level to maintain necessary reverse bias.

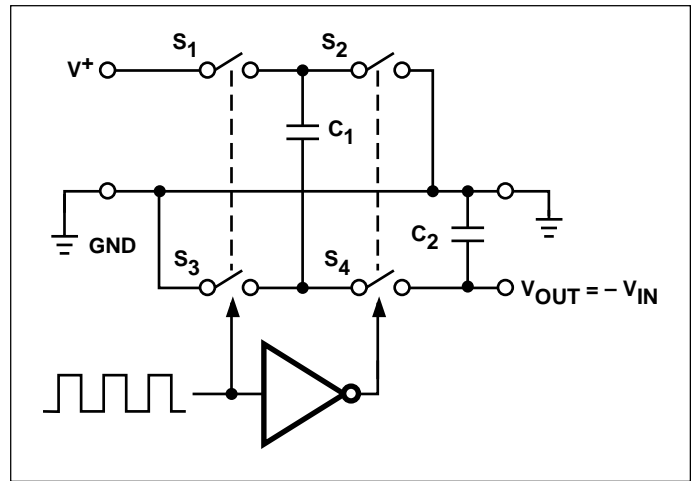

Figure 2. Idealized Charge Pump Inverter

The voltage regulator portion of the TC1044S is an integral part of the anti-latch-up circuitry. Its inherent voltage drop can, however, degrade operation at low voltages. To improve low-voltage operation, the "LV" pin should be connected to GND, disabling the regulator. For supply voltages greater than 3.5V, the LV terminal must be left open to ensure latch-up-proof operation and prevent device damage.

### Theoretical Power Efficiency Considerations

In theory, a capacitive charge pump can approach 100% efficiency if certain conditions are met:

- (1) The drive circuitry consumes minimal power.
- (2) The output switches have extremely low ON resistance and virtually no offset.
- (3) The impedances of the pump and reservoir capacitors are negligible at the pump frequency.

The TC1044S approaches these conditions for negative voltage multiplication if large values of  $C_1$  and  $C_2$  are used. **Energy is lost only in the transfer of charge between capacitors if a change in voltage occurs.** The energy lost is defined by:

$$E = 1/2 C_1 (V_1^2 - V_2^2)$$

$V_1$  and  $V_2$  are the voltages on  $C_1$  during the pump and transfer cycles. If the impedances of  $C_1$  and  $C_2$  are relatively high at the pump frequency (refer to Figure 2) compared to the value of  $R_L$ , there will be a substantial difference in voltages  $V_1$  and  $V_2$ . Therefore, it is desirable not only to make  $C_2$  as large as possible to eliminate output voltage ripple, but also to employ a correspondingly large value for  $C_1$  in order to achieve maximum efficiency of operation.

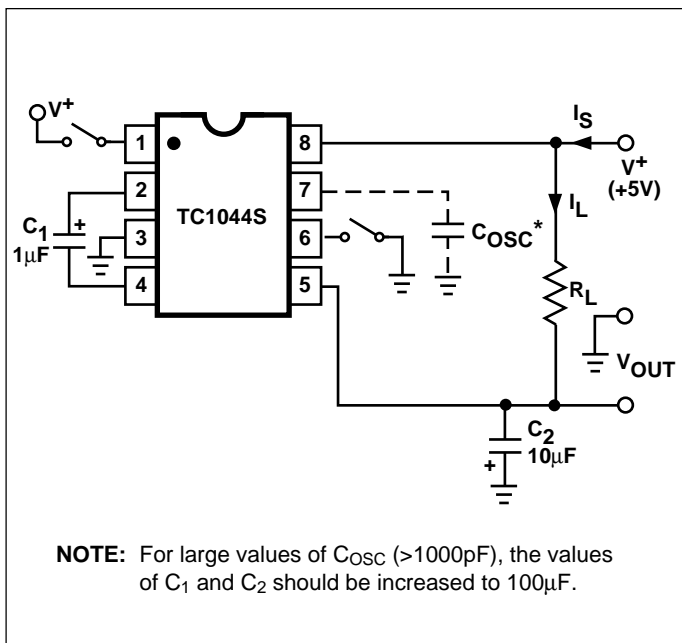

**NOTE:** For large values of  $C_{\text{OSC}}$  ( $>1000\text{pF}$ ), the values of  $C_1$  and  $C_2$  should be increased to  $100\mu\text{F}$ .

Figure 1. TC1044S Test Circuit

## TC1044S

### Dos and Don'ts

- Do not exceed maximum supply voltages.
- Do not connect the LV terminal to GND for supply voltages greater than 3.5V.
- Do not short circuit the output to  $V^+$  supply for voltages above 5.5V for extended periods; however, transient conditions including start-up are okay.
- When using polarized capacitors in the inverting mode, the + terminal of  $C_1$  must be connected to pin 2 of the TC1044S and the + terminal of  $C_2$  must be connected to GND.

### Simple Negative Voltage Converter

Figure 3 shows typical connections to provide a negative supply where a positive supply is available. A similar scheme may be employed for supply voltages anywhere in the operating range of +1.5V to +12V, keeping in mind that pin 6 (LV) is tied to the supply negative (GND) only for supply voltages below 3.5V.

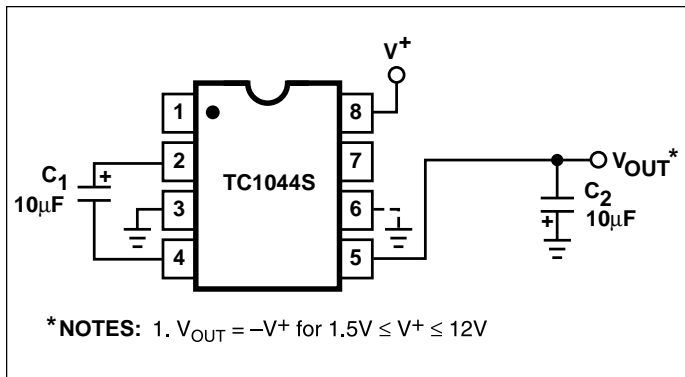

Figure 3. Simple Negative Converter

The output characteristics of the circuit in Figure 3 are those of a nearly ideal voltage source in series with  $70\Omega$ . Thus, for a load current of  $-10mA$  and a supply voltage of +5V, the output voltage would be  $-4.3V$ .

The dynamic output impedance of the TC1044S is due, primarily, to capacitive reactance of the charge transfer capacitor ( $C_1$ ). Since this capacitor is connected to the output for only 1/2 of the cycle, the equation is:

$$X_C = \frac{2}{2\pi f C_1} = 3.18\Omega,$$

where  $f = 10 \text{ kHz}$  and  $C_1 = 10\mu F$ .

### Paralleling Devices

Any number of TC1044S voltage converters may be paralleled to reduce output resistance (Figure 4). The reservoir capacitor,  $C_2$ , serves all devices, while each device requires its own pump capacitor,  $C_1$ . The resultant output resistance would be approximately:

$$R_{OUT} = \frac{R_{OUT} \text{ (of TC1044S)}}{n \text{ (number of devices)}}$$

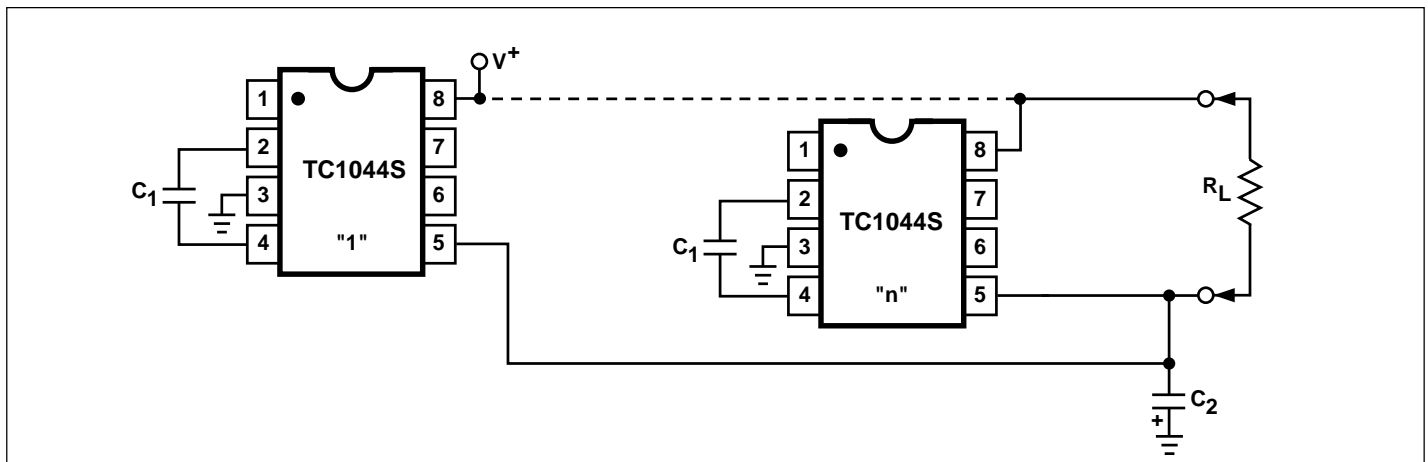

Figure 4. Paralleling Devices Lowers Output Impedance

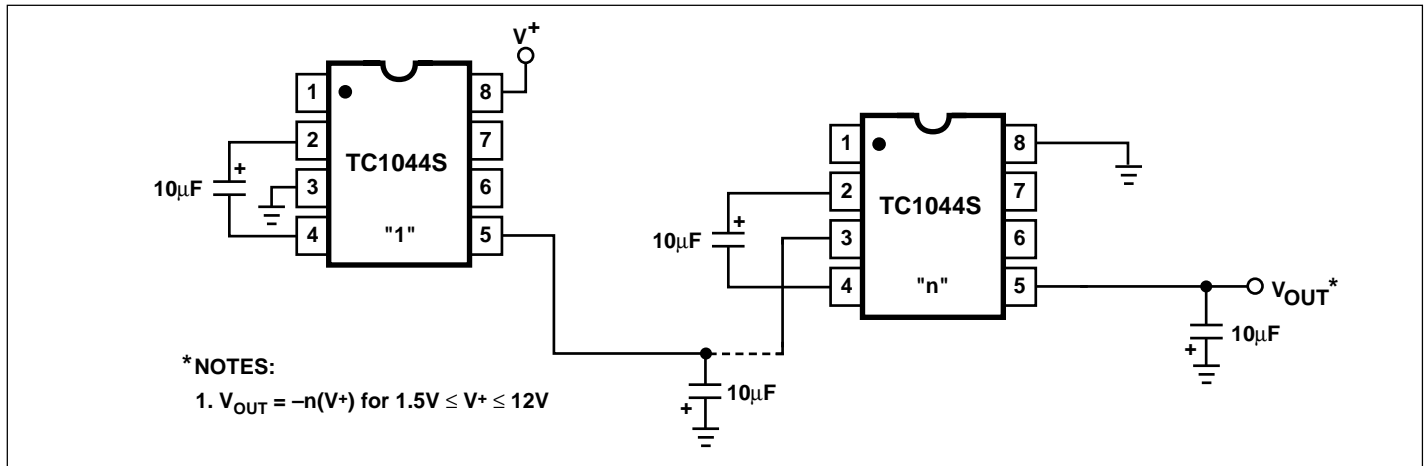

Figure 5. Increased Output Voltage by Cascading Devices

### Cascading Devices

The TC1044S may be cascaded as shown (Figure 5) to produce larger negative multiplication of the initial supply voltage. However, due to the finite efficiency of each device, the practical limit is 10 devices for light loads. The output voltage is defined by:

$$V_{OUT} = -n(V_{IN})$$

where  $n$  is an integer representing the number of devices cascaded. The resulting output resistance would be approximately the weighted sum of the individual TC1044S  $R_{OUT}$  values.

### Changing the TC1044S Oscillator Frequency

It may be desirable in some applications (due to noise or other considerations) to increase the oscillator frequency. Pin 1, frequency boost pin may be connected to  $V^+$  to increase oscillator frequency to 45kHz from a nominal of 10kHz for an input supply voltage of 5.0 volts. The oscillator may also be synchronized to an external clock as shown in Figure 6. In order to prevent possible device latch-up, a 1k $\Omega$  resistor must be used in series with the clock output. In a

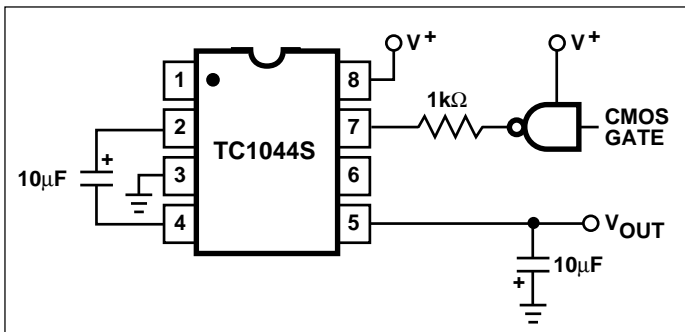

Figure 6. External Clocking

situation where the designer has generated the external clock frequency using TTL logic, the addition of a 10k $\Omega$  pull-up resistor to  $V^+$  supply is required. Note that the pump frequency with external clocking, as with internal clocking, will be 1/2 of the clock frequency. Output transitions occur on the positive-going edge of the clock.

It is also possible to increase the conversion efficiency of the TC1044S at low load levels by lowering the oscillator frequency. This reduces the switching losses, and is achieved by connecting an additional capacitor,  $C_{OSC}$ , as shown in Figure 7. Lowering the oscillator frequency will cause an undesirable increase in the impedance of the pump ( $C_1$ ) and the reservoir ( $C_2$ ) capacitors. To overcome this, increase the values of  $C_1$  and  $C_2$  by the same factor that the frequency has been reduced. For example, the addition of a 100pF capacitor between pin 7 (OSC) and pin 8 ( $V^+$ ) will lower the oscillator frequency to 1kHz from its nominal frequency of 10kHz (a multiple of 10), and necessitate a corresponding increase in the values of  $C_1$  and  $C_2$  (from 10 $\mu$ F to 100 $\mu$ F).

### Positive Voltage Multiplication

The TC1044S may be employed to achieve positive voltage multiplication using the circuit shown in Figure 8. In this application, the pump inverter switches of the TC1044S are used to charge  $C_1$  to a voltage level of  $V^+ - V_F$  (where  $V^+$  is the supply voltage and  $V_F$  is the forward voltage drop of diode  $D_1$ ). On the transfer cycle, the voltage on  $C_1$  plus the supply voltage ( $V^+$ ) is applied through diode  $D_2$  to capacitor  $C_2$ . The voltage thus created on  $C_2$  becomes  $(2V^+) - (2V_F)$ , or twice the supply voltage minus the combined forward voltage drops of diodes  $D_1$  and  $D_2$ .

The source impedance of the output ( $V_{OUT}$ ) will depend on the output current, but for  $V^+ = 5V$  and an output current of 10mA, it will be approximately 60 $\Omega$ .

## TC1044S

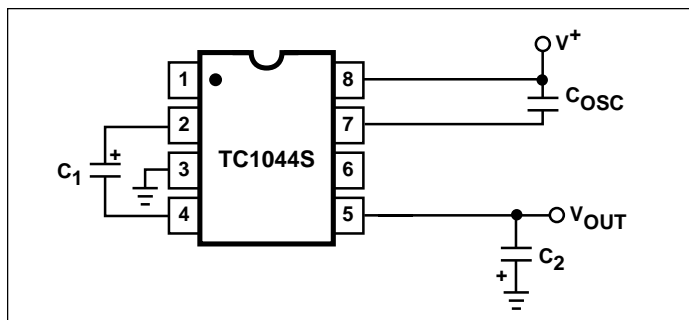

Figure 7. Lowering Oscillator Frequency

### Combined Negative Voltage Conversion and Positive Supply Multiplication

Figure 9 combines the functions shown in Figures 3 and 8 to provide negative voltage conversion and positive voltage multiplication simultaneously. This approach would be, for example, suitable for generating +9V and -5V from an existing +5V supply. In this instance, capacitors  $C_1$  and  $C_3$  perform the pump and reservoir functions, respectively, for the generation of the negative voltage, while capacitors  $C_2$  and  $C_4$  are pump and reservoir, respectively, for the multiplied positive voltage. There is a penalty in this configuration which combines both functions, however, in that the source impedances of the generated supplies will be somewhat higher due to the finite impedance of the common charge pump driver at pin 2 of the device.

### Efficient Positive Voltage Multiplication/Conversion

Since the switches that allow the charge pumping operation are bidirectional, the charge transfer can be performed backwards as easily as forwards. Figure 10 shows a TC1044S transforming -5V to +5V (or +5V to +10V, etc.). The only problem here is that the internal clock and switch-drive section will not operate until some positive voltage has been generated. An initial inefficient pump, as shown in Figure 9, could be used to start this circuit up, after which it

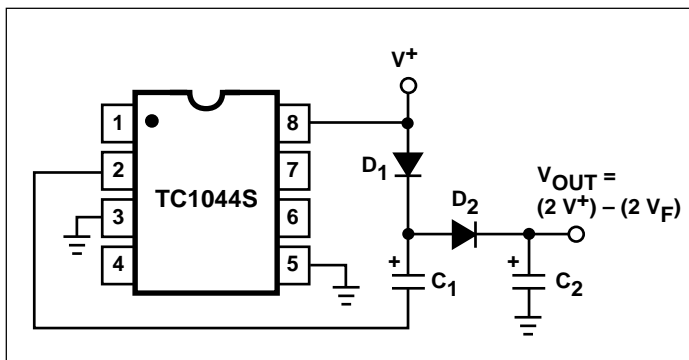

Figure 8. Positive Voltage Multiplier

will bypass the other ( $D_1$  and  $D_2$  in Figure 9 would never turn on), or else the diode and resistor shown dotted in Figure 10 can be used to "force" the internal regulator on.

### Voltage Splitting

The same bidirectional characteristics used in Figure 10 can also be used to split a higher supply in half, as shown in Figure 11. The combined load will be evenly shared between the two sides. Once again, a high value resistor to the LV pin ensures start-up. Because the switches share the load in parallel, the output impedance is much lower than in the standard circuits, and higher currents can be drawn from the device. By using this circuit, and then the circuit of Figure 5, +15V can be converted (via +7.5V and -7.5V) to a nominal -15V, though with rather high series resistance (~250Ω).

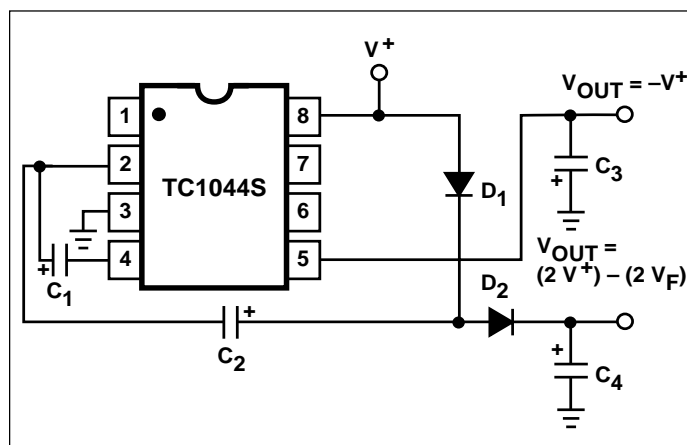

Figure 9. Combined Negative Converter and Positive Multiplier

### Negative Voltage Generation for Display ADCs

The TC7106 is designed to work from a 9V battery. With a fixed power supply system, the TC7106 will perform conversions with input signal referenced to power supply ground.

### Negative Supply Generation for 4½ Digit Data Acquisition System

The TC7135 is a 4½ digit ADC operating from ±5V supplies. The TC1044S provides an inexpensive -5V source. (See AN16 and AN17 for TC7135 interface details and software routines.)

# Charge Pump DC-TO-DC Voltage Converter

TC1044S

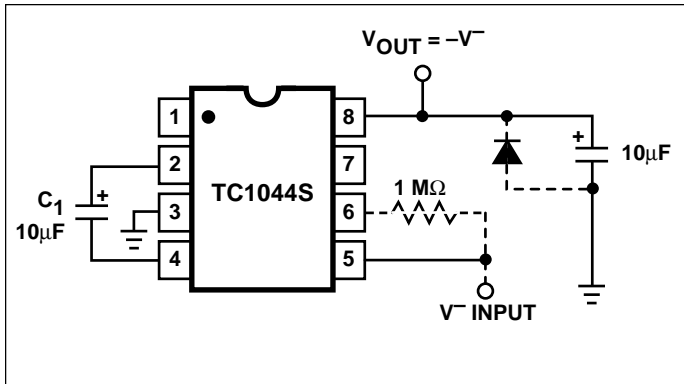

Figure 10. Positive Voltage Conversion

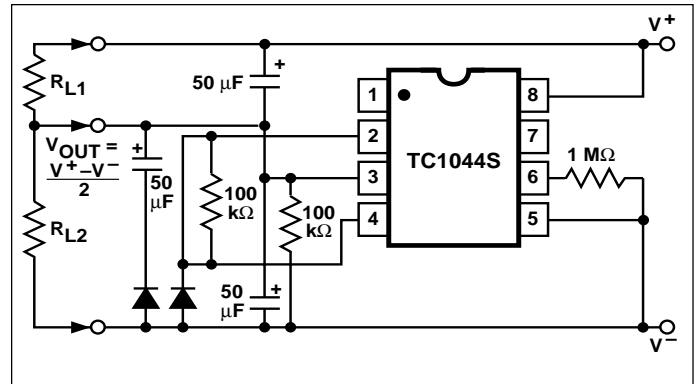
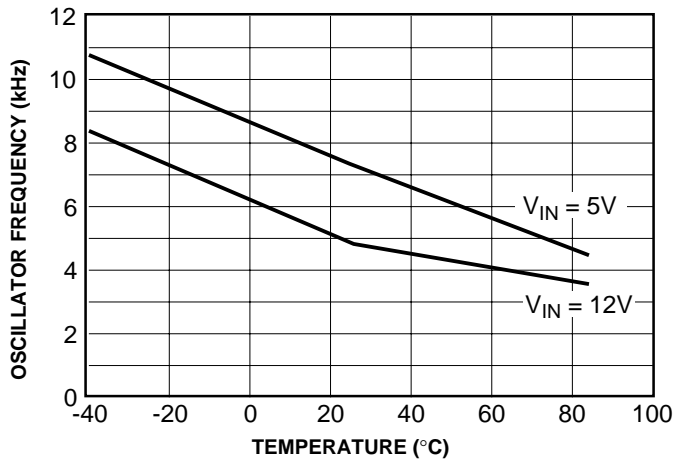

Figure 11. Splitting a Supply in Half

## TYPICAL CHARACTERISTICS

Unloaded Osc Freq vs. Temperature



Unloaded Osc Freq vs. Temperature with Boost Pin = VIN

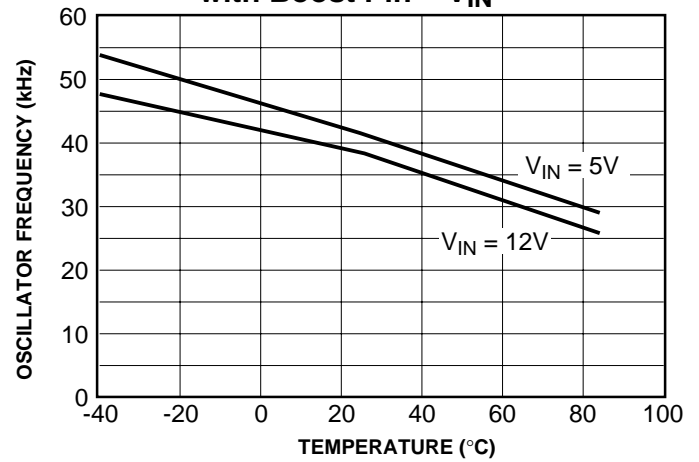

Supply Current vs. Temperature (with Boost Pin = VIN)

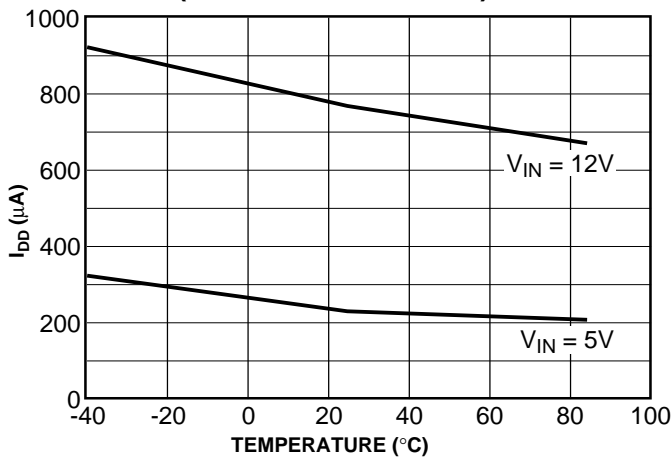

Voltage Conversion

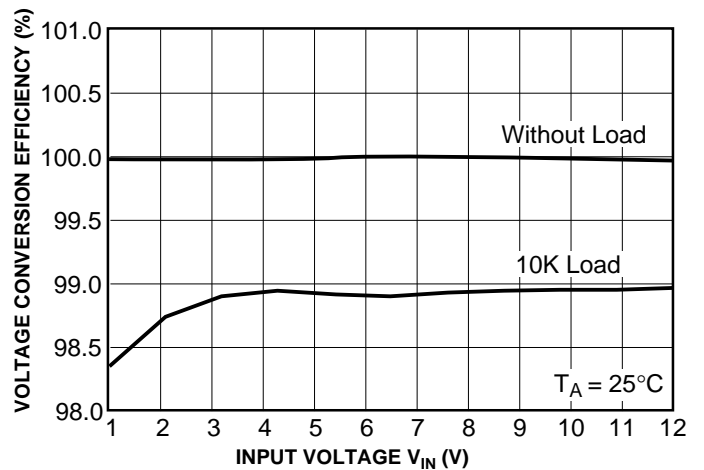

# Charge Pump DC-TO-DC Voltage Converter

## TC1044S

### TYPICAL CHARACTERISTICS (Cont.)

**Output Source Resistance vs. Supply Voltage**

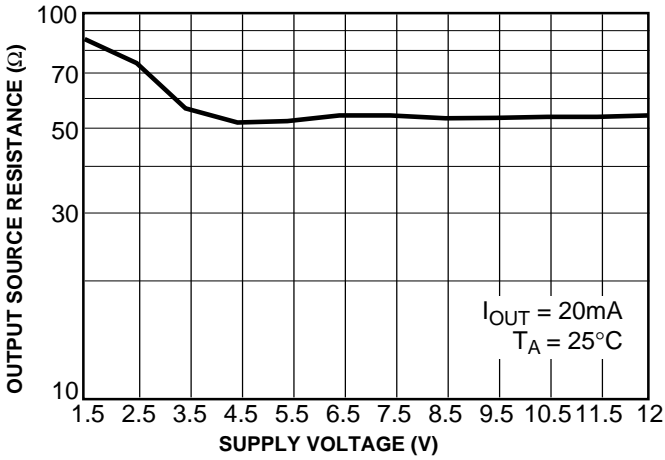

**Output Source Resistance vs. Temperature**

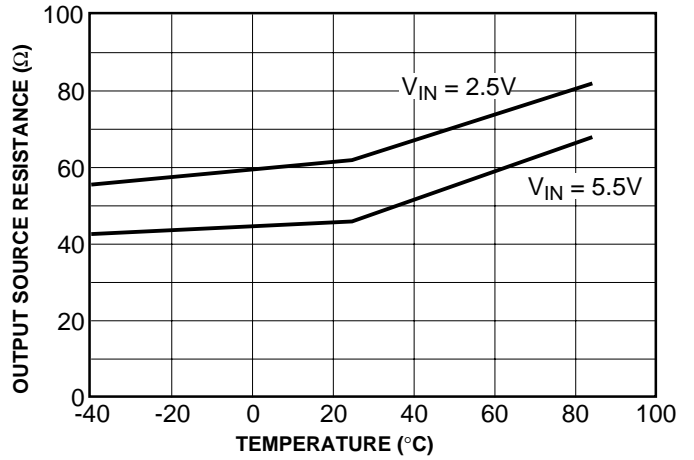

**Output Voltage vs. Output Current**

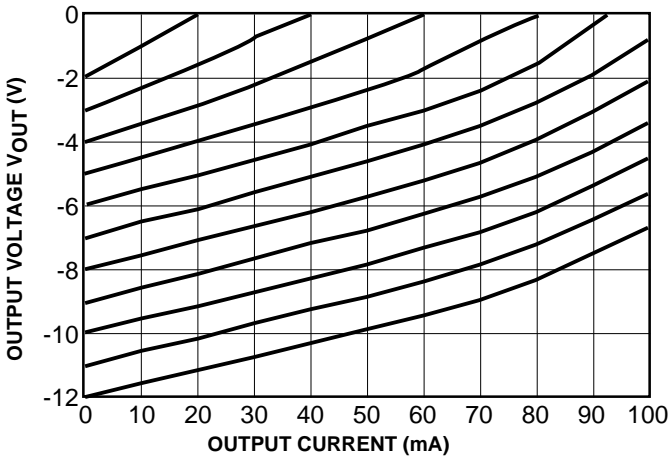

**Power Conversion Efficiency vs. Load**

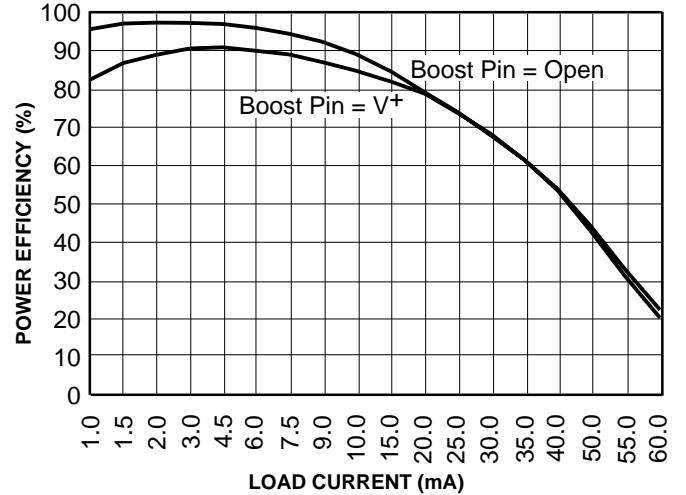

**Supply Current vs. Temperature**

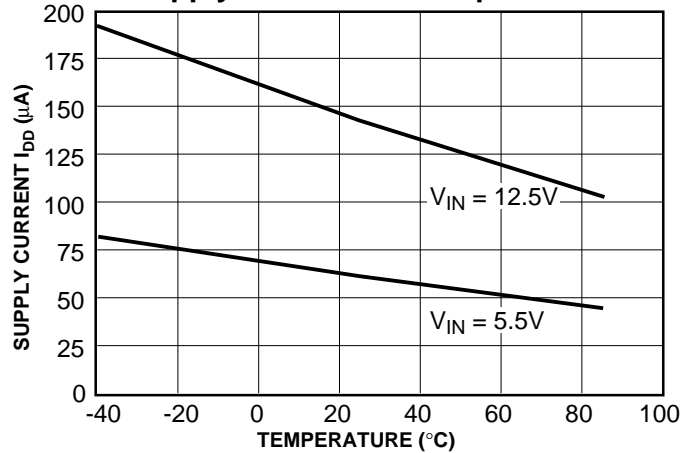



### PACKAGE DIMENSIONS

#### 8-Pin Plastic DIP

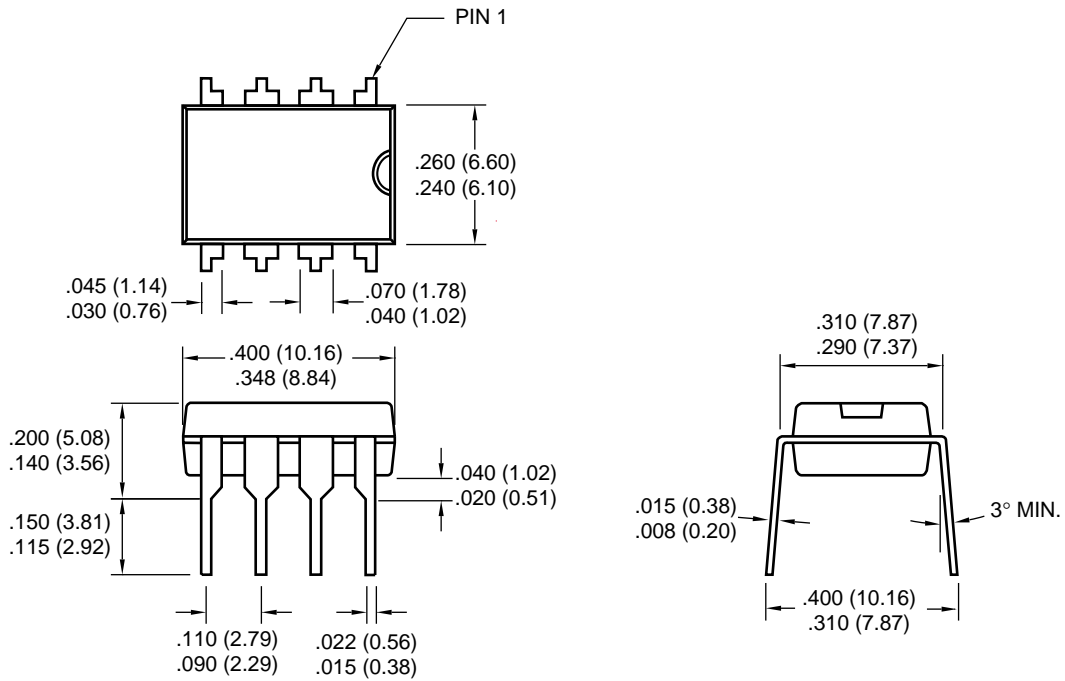

#### 8-Pin CerDIP

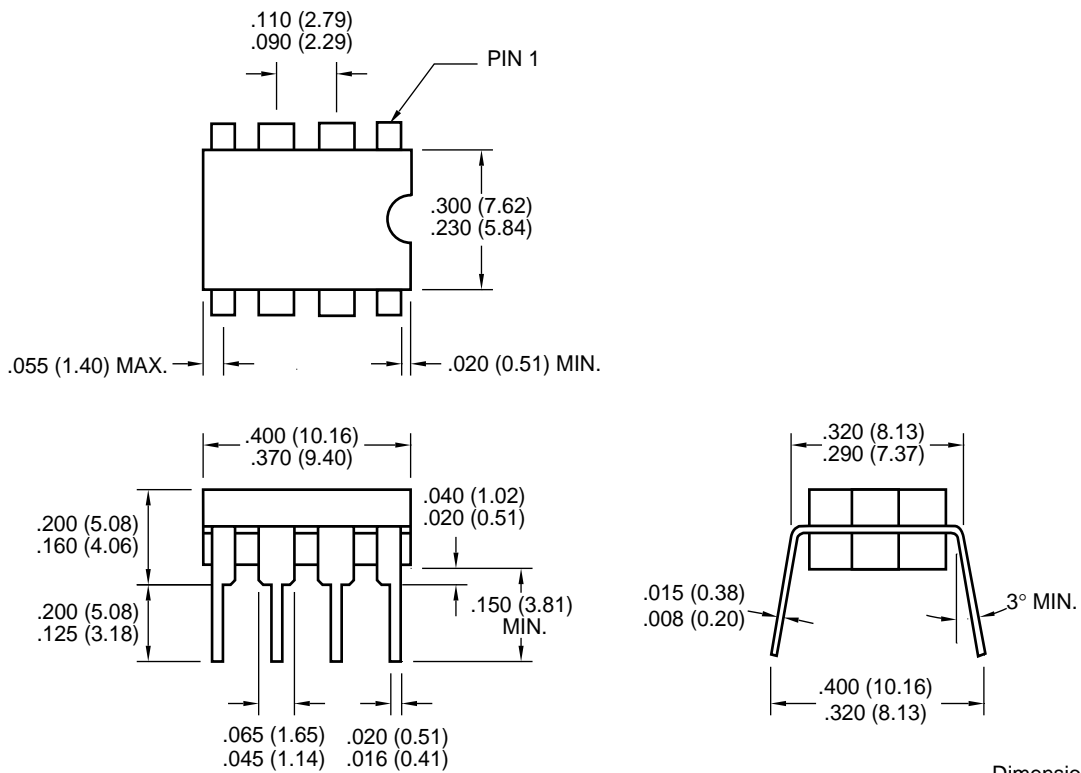

Dimensions: inches (mm)

## TC1044S

### PACKAGE DIMENSIONS (CONT.)

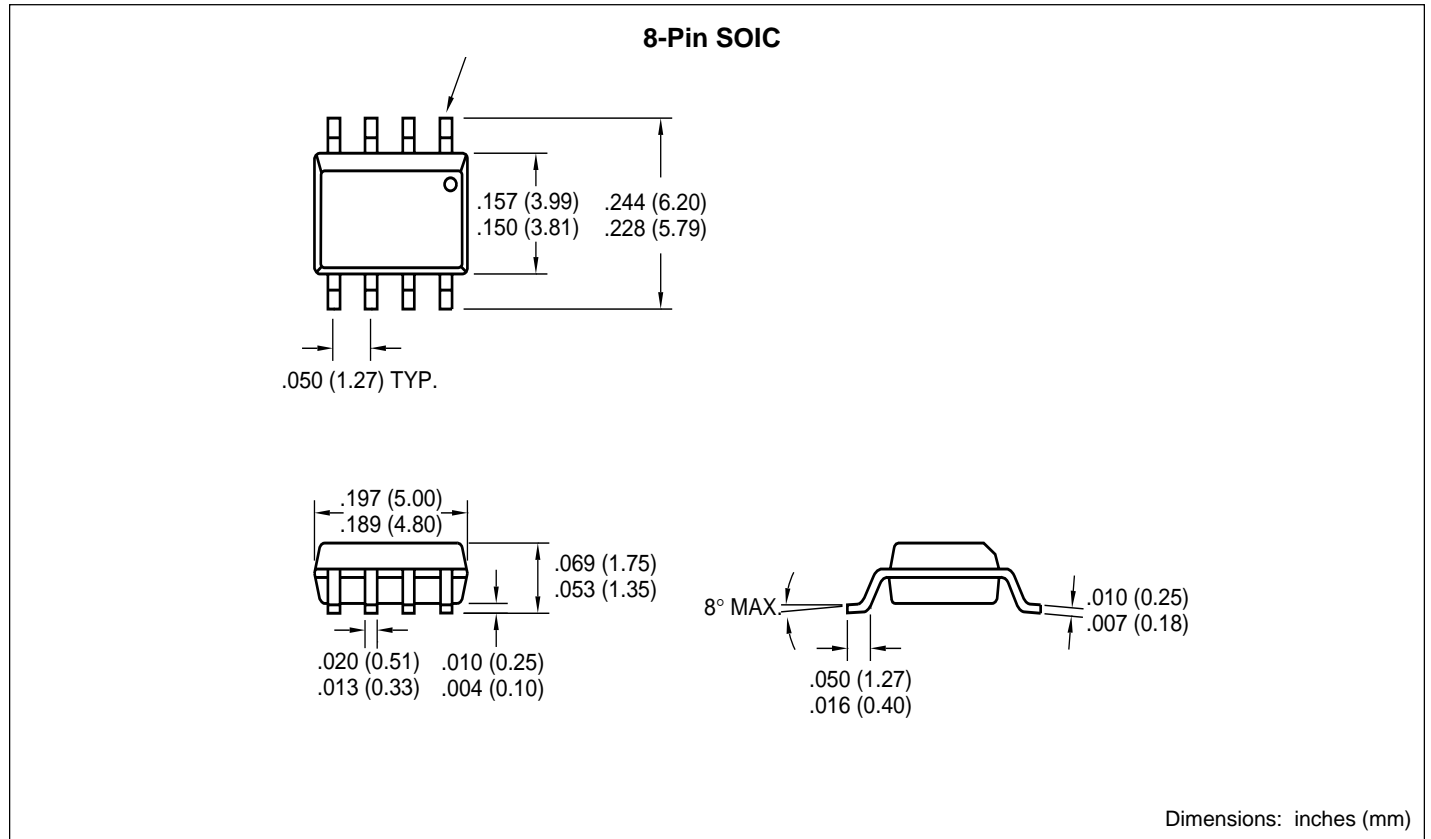



## WORLDWIDE SALES AND SERVICE

### AMERICAS

#### Corporate Office

2355 West Chandler Blvd.  
Chandler, AZ 85224-6199  
Tel: 480-792-7200 Fax: 480-792-7277  
Technical Support: 480-792-7627  
Web Address: <http://www.microchip.com>

#### Rocky Mountain

2355 West Chandler Blvd.  
Chandler, AZ 85224-6199  
Tel: 480-792-7966 Fax: 480-792-7456

#### Atlanta

500 Sugar Mill Road, Suite 200B  
Atlanta, GA 30350  
Tel: 770-640-0034 Fax: 770-640-0307

#### Austin

Analog Product Sales  
8303 MoPac Expressway North  
Suite A-201  
Austin, TX 78759  
Tel: 512-345-2030 Fax: 512-345-6085

#### Boston

2 Lan Drive, Suite 120  
Westford, MA 01886  
Tel: 978-692-3848 Fax: 978-692-3821

#### Boston

Analog Product Sales  
Unit A-8-1 Millbrook Tarry Condominium  
97 Lowell Road  
Concord, MA 01742  
Tel: 978-371-6400 Fax: 978-371-0050

#### Chicago

333 Pierce Road, Suite 180  
Itasca, IL 60143  
Tel: 630-285-0071 Fax: 630-285-0075

#### Dallas

4570 Westgrove Drive, Suite 160  
Addison, TX 75001  
Tel: 972-818-7423 Fax: 972-818-2924

#### Dayton

Two Prestige Place, Suite 130  
Miamisburg, OH 45342  
Tel: 937-291-1654 Fax: 937-291-9175

#### Detroit

Tri-Atria Office Building  
32255 Northwestern Highway, Suite 190  
Farmington Hills, MI 48334  
Tel: 248-538-2250 Fax: 248-538-2260

#### Los Angeles

18201 Von Karman, Suite 1090  
Irvine, CA 92612  
Tel: 949-263-1888 Fax: 949-263-1338

#### Mountain View

Analog Product Sales  
1300 Terra Bella Avenue  
Mountain View, CA 94043-1836  
Tel: 650-968-9241 Fax: 650-967-1590

#### New York

150 Motor Parkway, Suite 202  
Hauppauge, NY 11788  
Tel: 631-273-5305 Fax: 631-273-5335

#### San Jose

Microchip Technology Inc.  
2107 North First Street, Suite 590  
San Jose, CA 95131  
Tel: 408-436-7950 Fax: 408-436-7955

#### Toronto

6285 Northam Drive, Suite 108  
Mississauga, Ontario L4V 1X5, Canada  
Tel: 905-673-0699 Fax: 905-673-6509

### ASIA/PACIFIC

#### China - Beijing

Microchip Technology Beijing Office  
Unit 915  
New China Hong Kong Manhattan Bldg.  
No. 6 Chaoyangmen Beidajie  
Beijing, 100027, No. China  
Tel: 86-10-85282100 Fax: 86-10-85282104

#### China - Shanghai

Microchip Technology Shanghai Office  
Room 701, Bldg. B  
Far East International Plaza  
No. 317 Xian Xia Road  
Shanghai, 200051  
Tel: 86-21-6275-5700 Fax: 86-21-6275-5060

#### Hong Kong

Microchip Asia Pacific  
RM 2101, Tower 2, Metroplaza  
223 Hing Fong Road  
Kwai Fong, N.T., Hong Kong  
Tel: 852-2401-1200 Fax: 852-2401-3431

#### India

Microchip Technology Inc.  
India Liaison Office  
Divyasree Chambers  
1 Floor, Wing A (A3/A4)  
No. 11, O'Shaughnessy Road  
Bangalore, 560 025, India  
Tel: 91-80-2290061 Fax: 91-80-2290062

#### Japan

Microchip Technology Intl. Inc.  
Benex S-1 6F  
3-18-20, Shinyokohama  
Kohoku-Ku, Yokohama-shi  
Kanagawa, 222-0033, Japan  
Tel: 81-45-471- 6166 Fax: 81-45-471-6122

#### Korea

Microchip Technology Korea  
168-1, Youngbo Bldg. 3 Floor  
Samsung-Dong, Kangnam-Ku  
Seoul, Korea  
Tel: 82-2-554-7200 Fax: 82-2-558-5934

### ASIA/PACIFIC (continued)

#### Singapore

Microchip Technology Singapore Pte Ltd.  
200 Middle Road  
#07-02 Prime Centre  
Singapore, 188980  
Tel: 65-334-8870 Fax: 65-334-8850

#### Taiwan

Microchip Technology Taiwan  
11F-3, No. 207  
Tung Hua North Road  
Taipei, 105, Taiwan  
Tel: 886-2-2717-7175 Fax: 886-2-2545-0139

### EUROPE

#### Australia

Microchip Technology Australia Pty Ltd  
Suite 22, 41 Rawson Street  
Epping 2121, NSW  
Australia  
Tel: 61-2-9868-6733 Fax: 61-2-9868-6755

#### Denmark

Microchip Technology Denmark ApS  
Regus Business Centre  
Lautrup høj 1-3  
Ballerup DK-2750 Denmark  
Tel: 45 4420 9895 Fax: 45 4420 9910

#### France

Arizona Microchip Technology SARM  
Parc d'Activite du Moulin de Massy  
43 Rue du Saule Trapu  
Batiment A - ler Etage  
91300 Massy, France  
Tel: 33-1-69-53-63-20 Fax: 33-1-69-30-90-79

#### Germany

Arizona Microchip Technology GmbH  
Gustav-Heinemann Ring 125  
D-81739 Munich, Germany  
Tel: 49-89-627-144 0 Fax: 49-89-627-144-44

#### Germany

Analog Product Sales  
Lochhamer Strasse 13  
D-82152 Martinsried, Germany  
Tel: 49-89-895650-0 Fax: 49-89-895650-22

#### Italy

Arizona Microchip Technology SRL  
Centro Direzionale Colleoni  
Palazzo Taurus 1 V. Le Colleoni 1  
20041 Agrate Brianza  
Milan, Italy  
Tel: 39-039-65791-1 Fax: 39-039-6899883

#### United Kingdom

Arizona Microchip Technology Ltd.  
505 Eskdale Road  
Winnersh Triangle  
Wokingham  
Berkshire, England RG41 5TU  
Tel: 44 118 921 5869 Fax: 44-118 921-5820

All rights reserved. © 2001 Microchip Technology Incorporated. Printed in the USA. 1/01  Printed on recycled paper.

01/09/01

Information contained in this publication regarding device applications and the like is intended through suggestion only and may be superseded by updates. It is your responsibility to ensure that your application meets with your specifications. No representation or warranty is given and no liability is assumed by Microchip Technology Incorporated with respect to the accuracy or use of such information, or infringement of patents or other intellectual property rights arising from such use or otherwise. Use of Microchip's products as critical components in life support systems is not authorized except with express written approval by Microchip. No licenses are conveyed, implicitly or otherwise, except as maybe explicitly expressed herein, under any intellectual property rights. The Microchip logo and name are registered trademarks of Microchip Technology Inc. in the U.S.A. and other countries. All rights reserved. All other trademarks mentioned herein are the property of their respective companies.



Компания «ЭлектроПласт» предлагает заключение долгосрочных отношений при поставках импортных электронных компонентов на взаимовыгодных условиях!

Наши преимущества:

- Оперативные поставки широкого спектра электронных компонентов отечественного и импортного производства напрямую от производителей и с крупнейших мировых складов;
- Поставка более 17-ти миллионов наименований электронных компонентов;
- Поставка сложных, дефицитных, либо снятых с производства позиций;
- Оперативные сроки поставки под заказ (от 5 рабочих дней);
- Экспресс доставка в любую точку России;
- Техническая поддержка проекта, помощь в подборе аналогов, поставка прототипов;
- Система менеджмента качества сертифицирована по Международному стандарту ISO 9001;
- Лицензия ФСБ на осуществление работ с использованием сведений, составляющих государственную тайну;
- Поставка специализированных компонентов (Xilinx, Altera, Analog Devices, Intersil, Interpoint, Microsemi, Aeroflex, Peregrine, Syfer, Eurofarad, Texas Instrument, Miteq, Cobham, E2V, MA-COM, Hittite, Mini-Circuits, General Dynamics и др.);

Помимо этого, одним из направлений компании «ЭлектроПласт» является направление «Источники питания». Мы предлагаем Вам помощь Конструкторского отдела:

- Подбор оптимального решения, техническое обоснование при выборе компонента;
- Подбор аналогов;
- Консультации по применению компонента;
- Поставка образцов и прототипов;
- Техническая поддержка проекта;
- Защита от снятия компонента с производства.



#### Как с нами связаться

**Телефон:** 8 (812) 309 58 32 (многоканальный)

**Факс:** 8 (812) 320-02-42

**Электронная почта:** [org@eplast1.ru](mailto:org@eplast1.ru)

**Адрес:** 198099, г. Санкт-Петербург, ул. Калинина, дом 2, корпус 4, литера А.