

LED DISPLAY**LTS-4817SW-P**
DATA SHEET

<u>ITEM</u>	<u>Description</u>	<u>By</u>	<u>DATE</u>
1	New Spec	Reo Lin	2011/08/24

FEATURES

- * 0.39 inch (10.0 mm) DIGIT HEIGHT
- * CONTINUOUS UNIFORM SEGMENTS
- * LOW POWER REQUIREMENT
- * EXCELLENT CHARACTERS APPEARANCE
- * HIGH BRIGHTNESS & HIGH CONTRAST
- * WIDE VIEWING ANGLE
- * SOLID STATE RELIABILITY
- * CATEGORIZED FOR LUMINOUS INTENSITY
- * SMD DISPLAY
- * **LEAD FREE PACKAGE (ACCORDING TO ROHS)**

DESCRIPTION

The LTS-4817SW-P is a 0.39 inch (10.0 mm) digit height single digit SMD display. This device uses LTW-C193 series InGaN white Chip LED. The display has gray face and white segments, and suitable for reverse mount assembly.

DEVICE

PART NO.	DESCRIPTION
InGaN White	Common Anode
LTS-4817SW-P	

PACKAGE DIMENSIONS

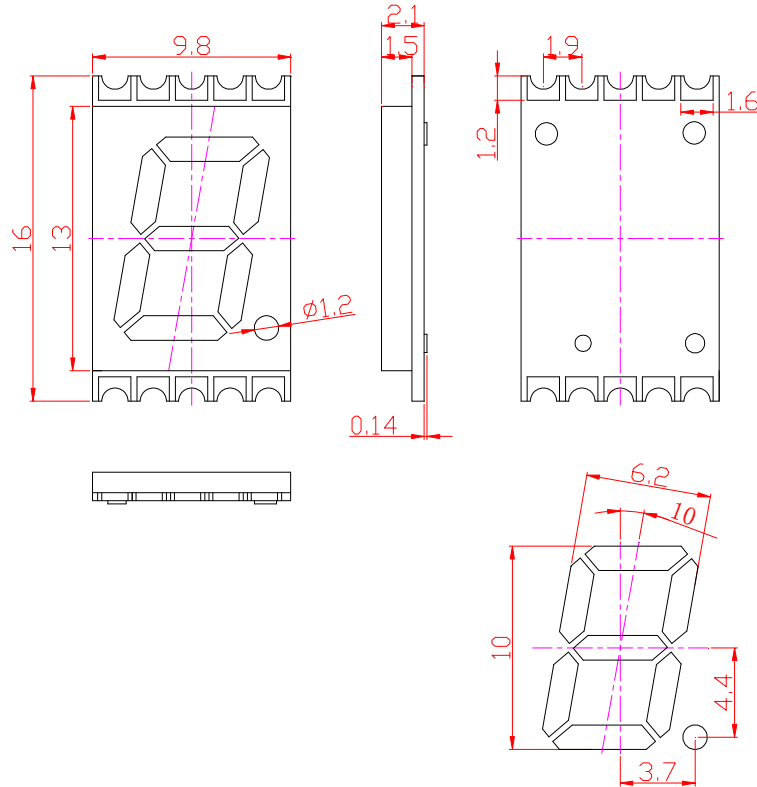

Solder Pad Vs Painting Diagram

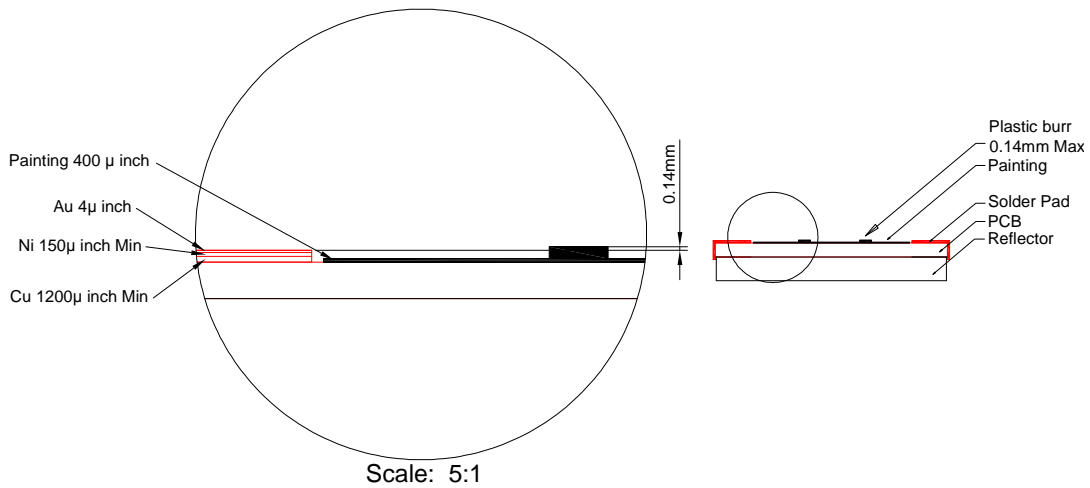

NOTES:

1. Plastic pins' burr max. 0.14 mm,
2. All dimensions are in millimeters. Tolerances are $\pm 0.25\text{mm}$ (0.01") unless otherwise noted.
3. Solder pad materials and thickness: Cu: 1200 μ inch Ni: Min 150 μ inch Au: 4 μ inch.

INTERNAL CIRCUIT DIAGRAM

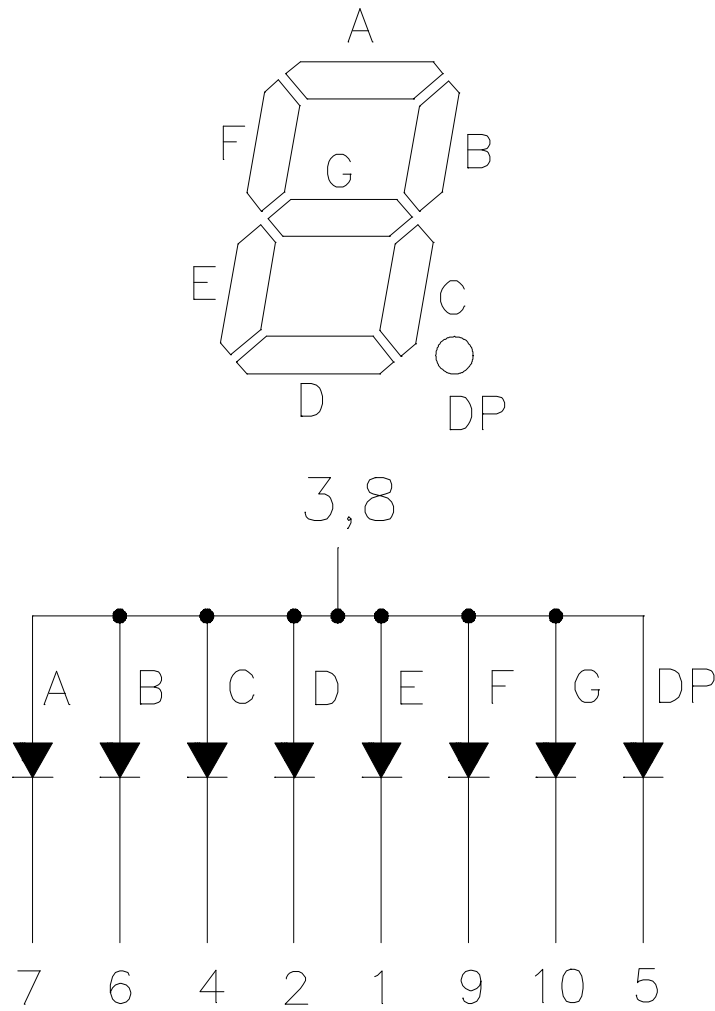

PIN CONNECTION

No.	CONNECTION
1	CATHODE E
2	CATHODE D
3	COMMON ANODE
4	CATHODE C
5	CATHODE D.P.
6	CATHODE B
7	CATHODE A
8	COMMON ANODE
9	CATHODE F
10	CATHODE G

ABSOLUTE MAXIMUM RATING AT Ta = 25°C

PARAMETER	MAXIMUM RATING	UNIT
Power Dissipation Per Segment	70	mW
Peak Forward Current Per Segment (Frequency 1Khz,10% duty cycle)	100	mA
Continuous Forward Current Per Segment	20	mA
Forward Current Derating from 25 °C	0.25	mA/°C
Operating Temperature Range	-35 °C to +80 °C	
Storage Temperature Range	-55 °C to +105 °C	
Iron Soldering Conditions: 1/16 inch Below Seating Plane for 3 Seconds at 260 °C		

ELECTRICAL / OPTICAL CHARACTERISTICS AT Ta = 25°C

PARAMETER	SYMBOL	MIN.	TYP.	MAX.	UNIT	TEST CONDITION
Luminous Intensity	IV	28.0	44.0		mcd	IF = 5mA Note 1, 2, 5
Chromaticity Coordinates	x		0.294			IF = 5mA Note 3, 5
	y		0.286			
Forward Voltage Per Segment	V _F	2.70		3.2	V	IF = 5mA
Reverse Current Per Segment	I _R			100	μA	V _R =5V Note 7

Note:

- Luminous intensity is measured with a light sensor and filter combination that approximates the CIE (Commision Internationale De L'Eclairage) eye-response curve.
- Iv classification code is marked on each packing bag.
- The chromaticity coordinates (x, y) is derived from the 1931 CIE chromaticity diagram.
- Caution in ESD:
Static Electricity and surge damages the LED. It is recommend using a wrist band or anti-electrostatic glove when handling the LED. All devices, equipment and machinery must be properly grounded.
- Tester: CAS140B is for the chromaticity coordinates (x, y) and IV.
- The chromaticity coordinates (x, y) guarantee should be added ± 0.01 tolerance.
- Reverse voltage is only for IR test. It can not continue to operate at this situation.

Chip LED Bin Code List

V_F Spec. Table		
V _F Bin	Forward Voltage (V) at I _F =5mA	
	Min.	Max
3	2.7	2.8
4	2.8	2.9
5	2.9	3.0
6	3.0	3.1
7	3.1	3.2

Tolerance on each Forward Voltage bin is +/-0.1 volt

I_v Spec. Table		
I _v Bin	I _v (mcd) at I _F =5mA	
	Min.	Max.
Q11	71.0	81.0
Q12	81.0	90.0
Q21	90.0	101.0
Q22	101.0	112.0
R11	112.0	129.0
R12	129.0	146.0
R21	146.0	165.0

Tolerance on each Luminous Intensity bin is +/-10%

Color Ranks Table					
Ranks	Color bin limits at I _F =5mA				
	CIE 1931 Chromaticity coordinates				
S1-2	x	0.284	0.284	0.294	0.294
	y	0.240	0.272	0.286	0.254
S2-2	x	0.284	0.284	0.294	0.294
	y	0.272	0.305	0.319	0.286
S3-1	x	0.294	0.294	0.304	0.304
	y	0.254	0.286	0.300	0.268

Property of Lite-On Only

S3-2	x	0.304	0.304	0.314	0.314
	y	0.268	0.300	0.315	0.282
S4-1	x	0.294	0.294	0.304	0.304
	y	0.286	0.319	0.333	0.300
S4-2	x	0.304	0.304	0.314	0.314
	y	0.300	0.333	0.347	0.315
S5-1	x	0.314	0.314	0.324	0.324
	y	0.282	0.315	0.329	0.296
S6-1	x	0.314	0.314	0.324	0.324
	y	0.315	0.347	0.361	0.329

Tolerance on each Hue (x,y) bin is +/- 0.01

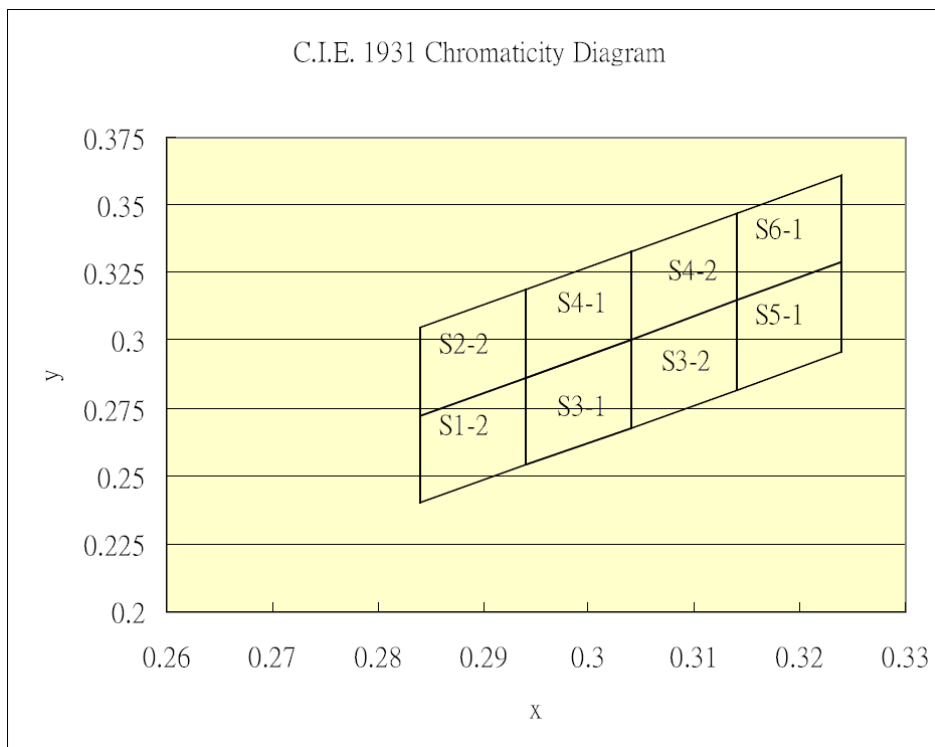

TYPICAL ELECTRICAL / OPTICAL CHARACTERISTIC CURVES

(25°C Ambient Temperature Unless Otherwise Noted)

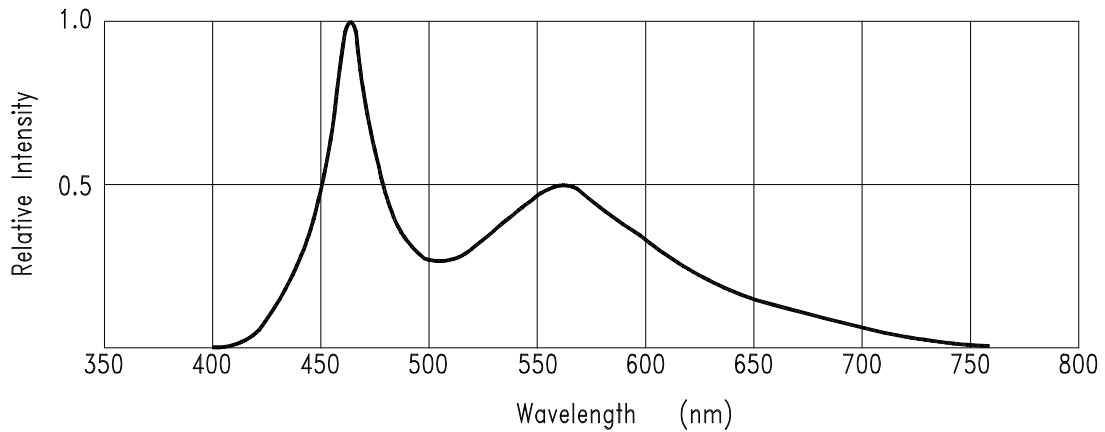

Fig.1 RELATIVE INTENSITY VS. WAVELENGTH

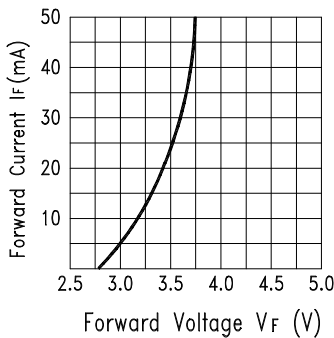

Fig.2 Forward Current vs. Forward Voltage

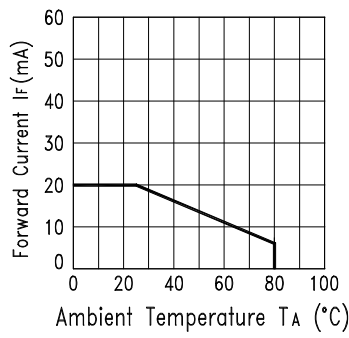

Fig.3 Forward Current Derating Curve

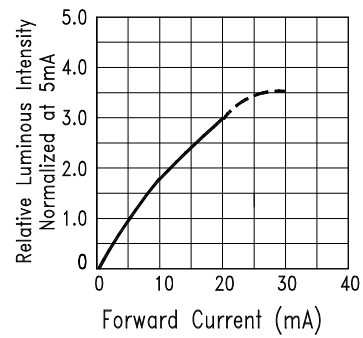

Fig.4 Relative Luminous Intensity vs. Forward Current

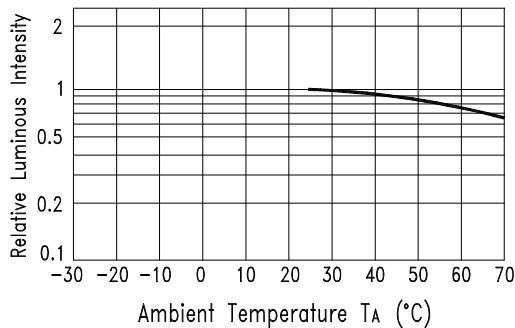

Fig.5 Luminous Intensity vs. Ambient Temperature

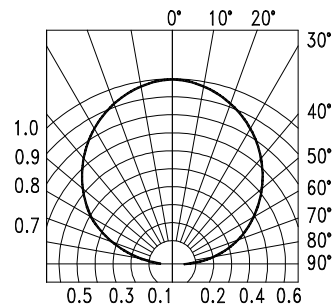
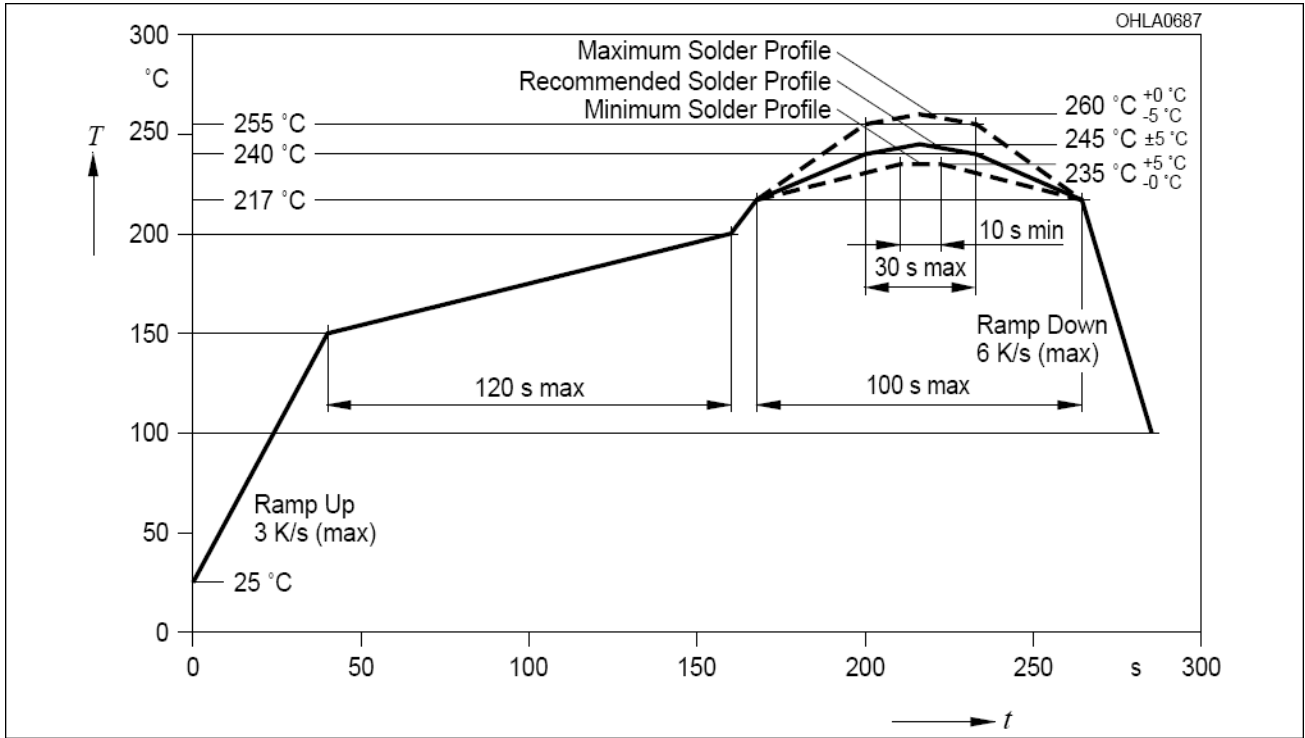

Fig.6 Spatial Distribution

SMT SOLDERING INSTRUCTION



Note:

1. Recommended soldering condition:

Reflow Soldering (Two times only)		Soldering Iron (One time only)	
Pre-heat:	120~150°C.	Temperature	300°C Max.
Pre-heat time:	120sec. Max.	Soldering time	3sec. Max.
Peak temperature:	260°C Max.		
Soldering time:	5sec. Max.		

2. Number of reflow process shall be less than 2 times, and cooling process to normal temperature is required between the first and the second soldering process.

RECOMMENDED SOLDERING PATTERN

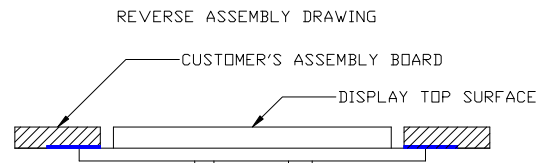
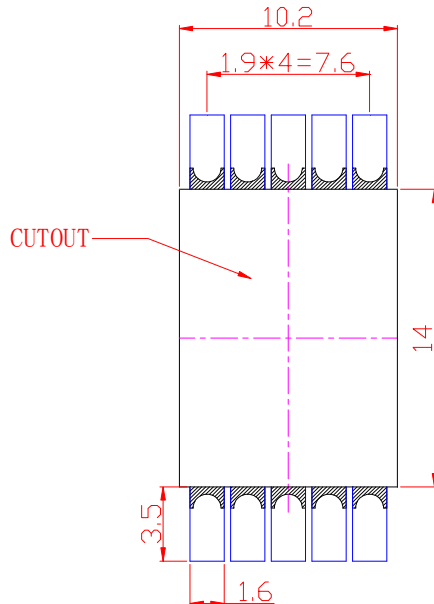

Note: All dimensions are in millimeters.

PACKING REEL DIMENSIONS

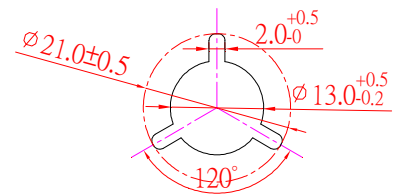
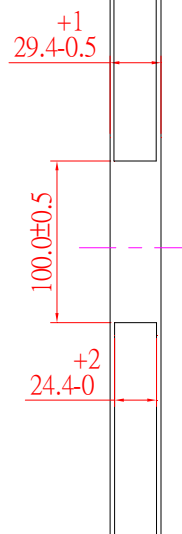
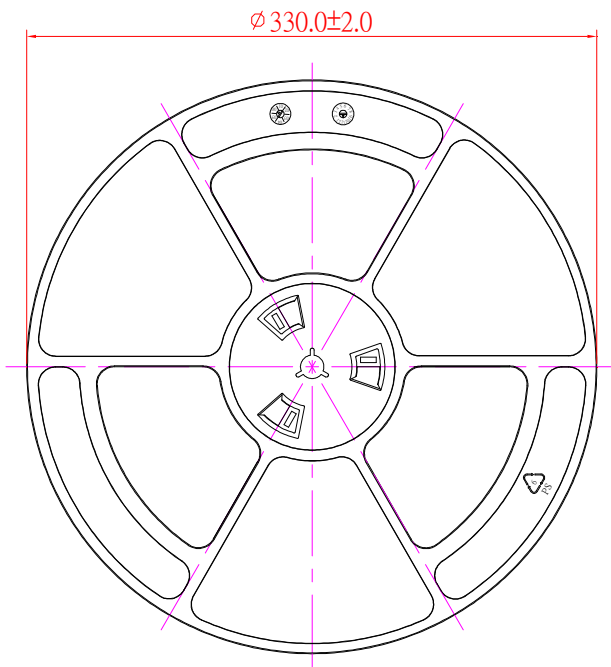

PACKING CARRIER DIMENSIONS

1. Taping parts:

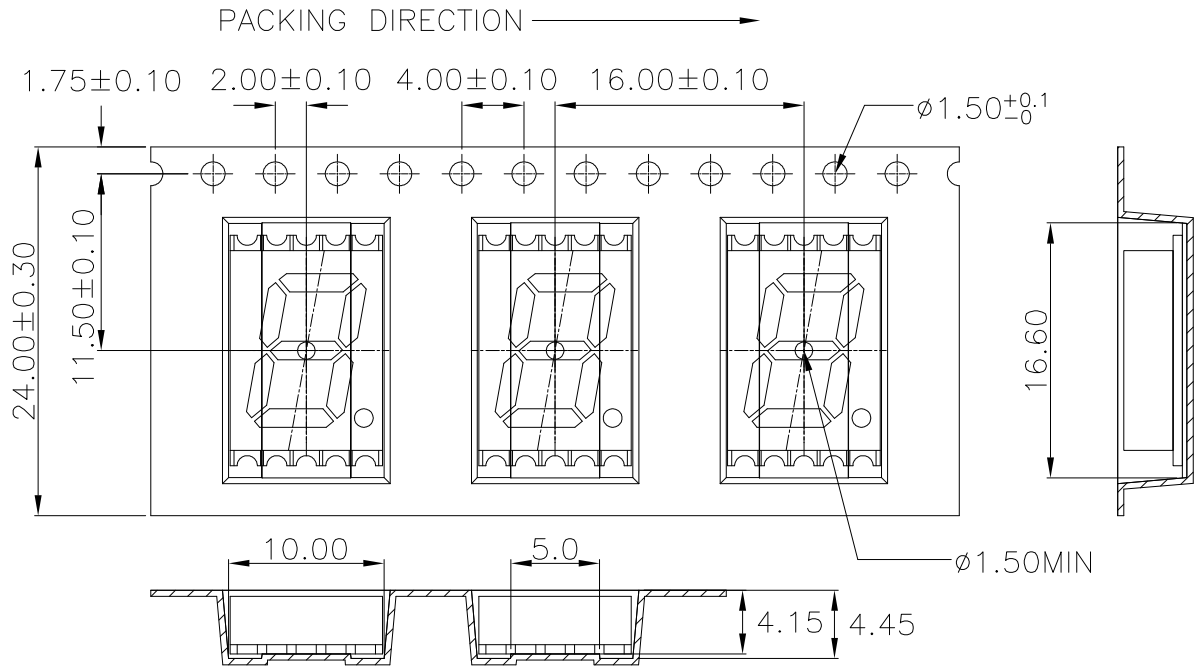

10 sprocket hole pitch cumulative tolerance ± 0.20 .
 Carrier camber is within 1 mm in 250 mm.
 Thickness : $0.40 \pm 0.05 \text{ mm}$.
 All dimensions meet EIA-481-C requirements.

2. Trailer part/ Leader part:

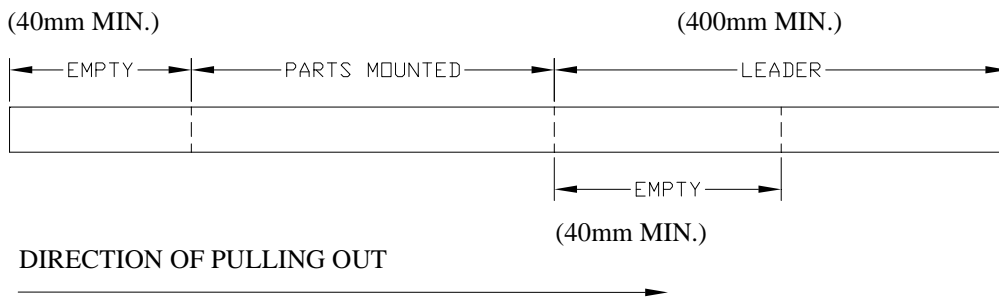

Moisture Proof Packaging

All N/D SMD displays are shipped in moisture proof package. The displays should be stored at 30°C or less and 90% RH or less. Once the package opened, moisture absorption begins.

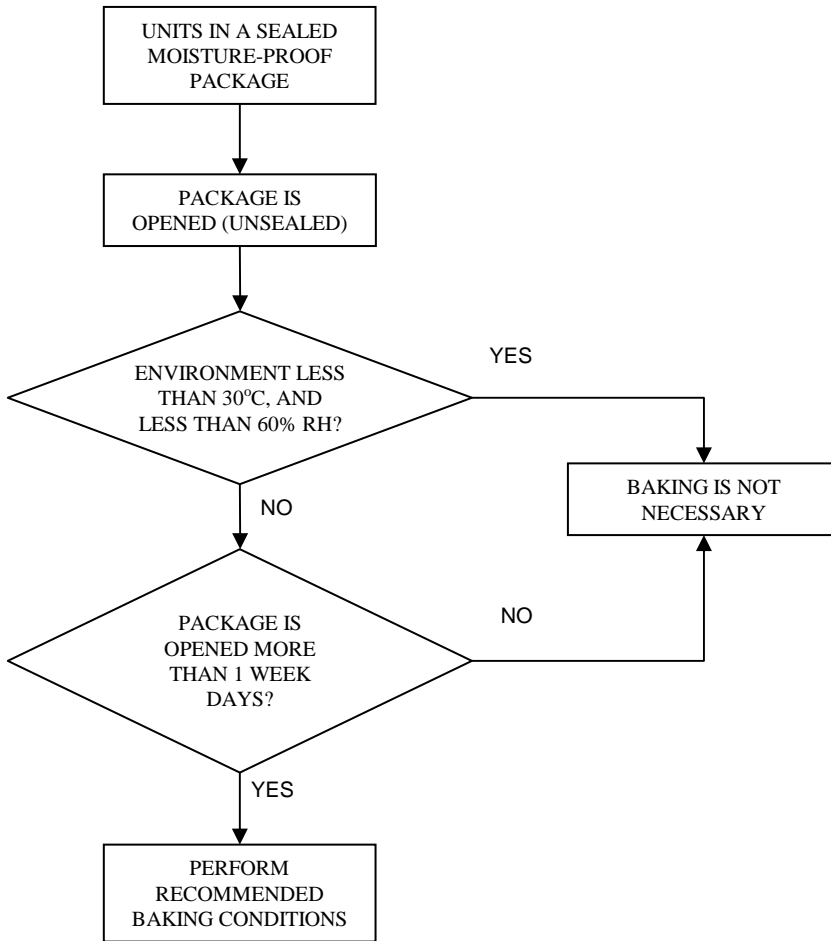

Baking Conditions

If the parts are not stored in dry conditions, they must be baked before reflow to prevent damage to the parts.

Package	Temperature	Time
In Reel	60°C	≥ 48hours
In Bulk	100°C	≥ 4hours
	125°C	≥ 2hours

Baking should only be done once.



Компания «ЭлектроПласт» предлагает заключение долгосрочных отношений при поставках импортных электронных компонентов на взаимовыгодных условиях!

Наши преимущества:

- Оперативные поставки широкого спектра электронных компонентов отечественного и импортного производства напрямую от производителей и с крупнейших мировых складов;
- Поставка более 17-ти миллионов наименований электронных компонентов;
- Поставка сложных, дефицитных, либо снятых с производства позиций;
- Оперативные сроки поставки под заказ (от 5 рабочих дней);
- Экспресс доставка в любую точку России;
- Техническая поддержка проекта, помощь в подборе аналогов, поставка прототипов;
- Система менеджмента качества сертифицирована по Международному стандарту ISO 9001;
- Лицензия ФСБ на осуществление работ с использованием сведений, составляющих государственную тайну;
- Поставка специализированных компонентов (Xilinx, Altera, Analog Devices, Intersil, Interpoint, Microsemi, Aeroflex, Peregrine, Syfer, Eurofarad, Texas Instrument, Miteq, Cobham, E2V, MA-COM, Hittite, Mini-Circuits, General Dynamics и др.);

Помимо этого, одним из направлений компании «ЭлектроПласт» является направление «Источники питания». Мы предлагаем Вам помощь Конструкторского отдела:

- Подбор оптимального решения, техническое обоснование при выборе компонента;
- Подбор аналогов;
- Консультации по применению компонента;
- Поставка образцов и прототипов;
- Техническая поддержка проекта;
- Защита от снятия компонента с производства.



Как с нами связаться

Телефон: 8 (812) 309 58 32 (многоканальный)

Факс: 8 (812) 320-02-42

Электронная почта: org@eplast1.ru

Адрес: 198099, г. Санкт-Петербург, ул. Калинина, дом 2, корпус 4, литера А.