

2.0 A switch-mode charger with intelligent power-path for 1-cell li-ion battery

The BC3770 is a fully programmable switching charger with dual-path output for single-cell Li-Ion and Li-Polymer battery. This dual-path output allows mobile applications with fully discharged battery or dead battery to boot up the system. High-efficiency and switch-mode operation of the BC3770 reduce heat dissipation and allow for higher current capability for a given package size. In addition, the BC3770 features single input with a 20 V withstanding input and charges the battery with the current up to 2.0 A. The charging parameters and operating modes are fully programmable over an I²C Interface that operates up to 400 kHz.

The BC3770 is a highly integrated synchronous switch-mode charger, featuring integrated OVP and Power FETs. The charger and boost regulator circuits switch at 1.5 MHz to minimize the size of external passive components. The BC3770 is able to operate as a boost regulator for USB-OTG function via either I²C command or an external pin from the host/processor. The BC3770 is available in a 25-bump, 2.27 mm x 2.17 mm, WLCSP package.

Features

- Dual-path output to power-up system in dead battery
- Single input for USB/TA
- High-efficiency synchronous switching regulator
- 20 V maximum withstanding input voltage
- Minimize the charging time with remote sense
- Up to 2.0 A load current for system or battery
- Programmable charge parameters via I²C compatible interface
- 400 kHz full-speed I²C interface
- 1.5 MHz switching frequency
- Charge reduction mode for maximizing charging efficiency

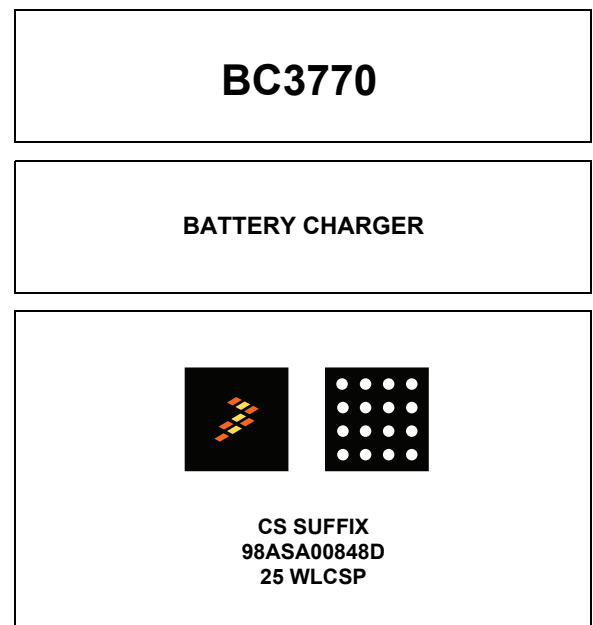

Applications

- Internet of things (IoT)
- Handheld consumer devices
- Wearable application
- mPOS terminals
- Medical portable equipment
- Consumer tablets

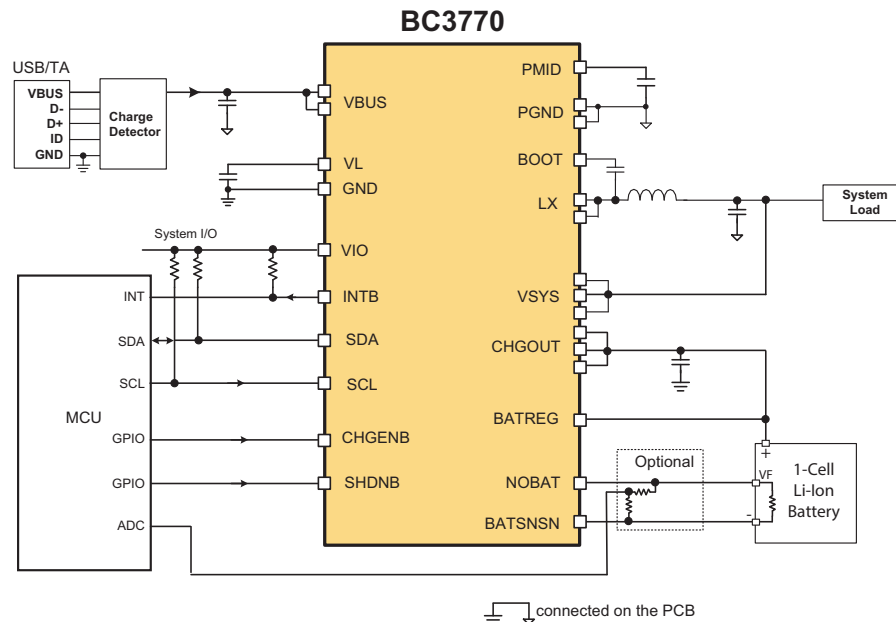

Figure 1. BC3770 simplified application diagram

* This document contains certain information on a new product. Specifications and information herein are subject to change without notice.

1 Orderable parts

Table 1. Orderable part variations

Part number	Temperature (T _A)	Package
MC32BC3770CSR2	-40 °C to 85 °C	25 WLCSP, 2.27 mm x 2.17 mm, 0.4 pitch

2 Internal block diagram

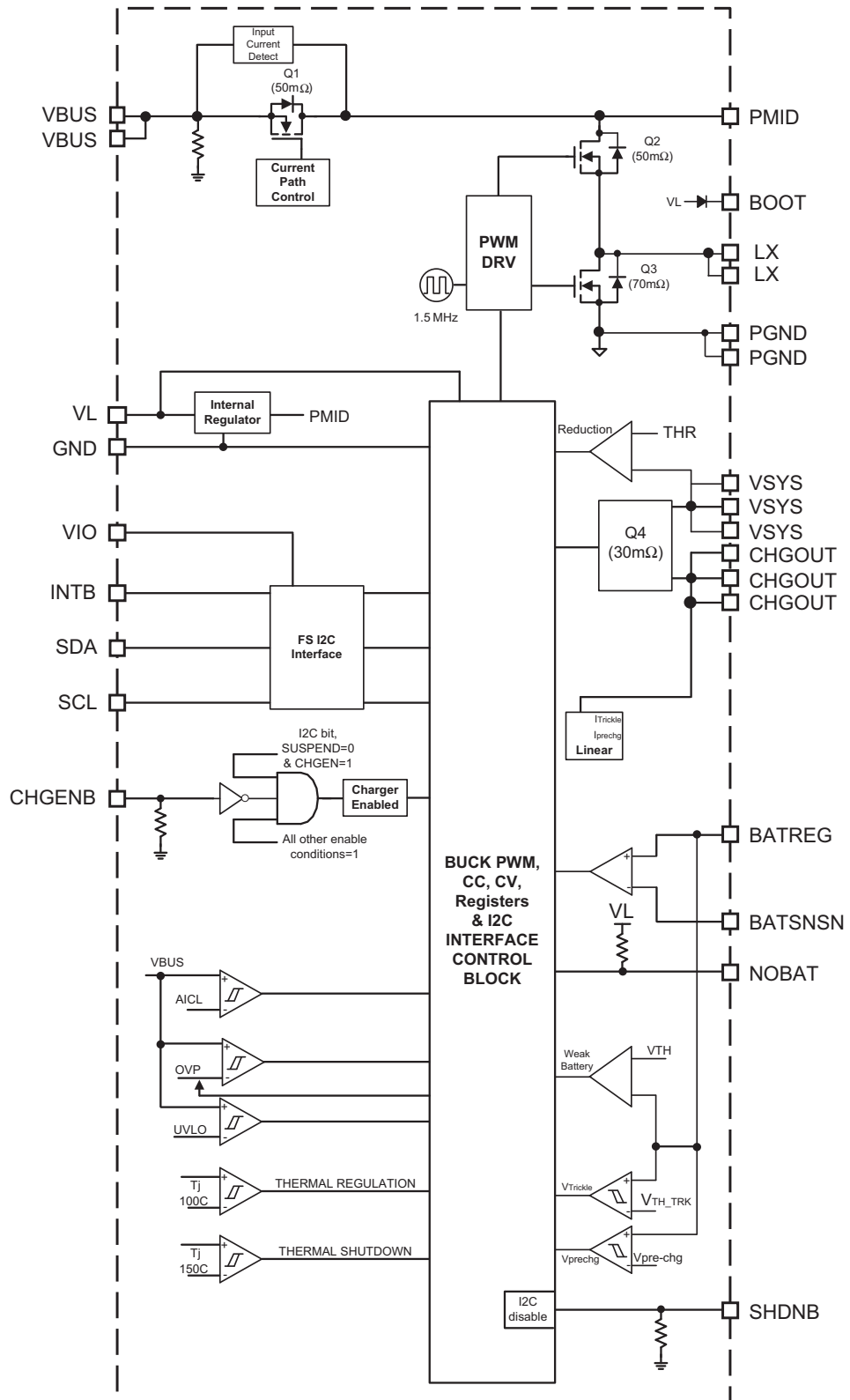

Figure 2. BC3770 simplified internal block diagram

3 Pin connections

TRANSPARENT
TOP VIEW

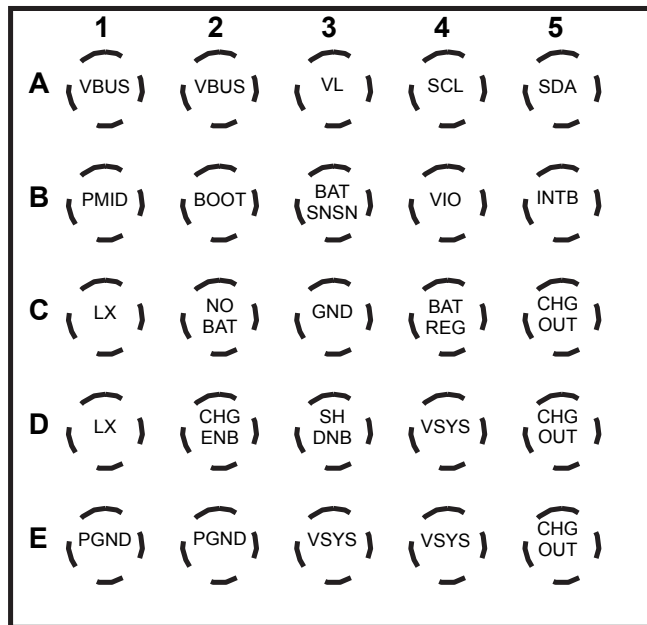

Figure 3. BC3770 pin connections (transparent top view)

Functional descriptions of many of these pins can be found in the Functional Pin Description section beginning on [page 13](#).

Table 2. BC3770 pin definitions

Pin	Pin name	Pin function	Formal name	Definition
A1, A2	VBUS	Input	USB/DCP Adapter Input	Connect the pins to the output of USB or DCP (dedicated Charging Port) adapter. Bypass with a 2.2 μ F/10 V ceramic capacitor to the ground, in case the peak voltage on the pins is always below 10 V due to a clamp device. Otherwise, a 2.2 μ F/25 V or higher rating capacitor is recommended. The two VBUS pins must be connected together externally. These pins are used as an output in OTG mode. An embedded 100 k Ω discharge resistance is enabled in Charge mode. It is disconnected in the Boost mode.
A3	VL	Output	Internal Regulator Output	The analog output for internal reference, bandgap and so on. DO NOT LOAD. Bypass with a 1.0 μ F/10 V to ground.
A4	SCL	Input	Clock Input for FS I ² C Serial Interface with the Processor	Use a pull-up resistor, 1.5 k Ω to 2.2 k Ω , to the VIO.
A5	SDA	Input/Output	Data I/O for FS I ² C Serial Interface with the Processor	Use a pull-up resistor, 1.5 k Ω to 2.2 k Ω , to the VIO.
B1	PMID	Output	VBUS Bypass Output	High-side MOSFET connection node and VBUS bypass output. Bypass with a 2.2 μ F ceramic capacitor to PGND pins as close as possible. Do NOT LOAD any external applications.
B2	BOOT		High-side MOSFET Driver Supply	Bypass BOOT to LX with a 22 nF/10 V ceramic capacitor.
B3	BATSNSN		Battery - Terminal Sensing	Connect to negative terminal of battery cell as close as possible. If a sense resistor is used for a fuel gauge, connect the pin to the ground terminal of the sense resistor.
B4	VIO		Supply for Internal Buffer	Connect to the system I/O supply voltage rail.

Table 2. BC3770 pin definitions (continued)

Pin	Pin name	Pin function	Formal name	Definition
B5	INTB	Output	Logic Output for Interrupt	An open-drain output with an external pull-up resistor, 200 k Ω , to the system I/O supply. Active-low when status change on interrupt registers occurs.
C1, D1	LX		Switching Node	Connect a 1.0 μ H inductor. The two LX pins must be connected together externally.
C2	NOBAT	Input	Logic Input for Battery Presence Detection	Connect the pin to VF or ID pin on the battery cell. It has an internal pull-up resistance, 300 k Ω typ, to the VL. If a logic-high threshold is detected on the pin, the charging is suspended immediately. If this pin is not used, connect it to ground.
C3	GND	Ground	Device Ground	Must be connected to the system ground.
C4	BATREG		Battery + Terminal Sensing	Connect to positive terminal of battery cell as close as possible.
C5, D5, E5	CHGOUT	Output	Battery Charger Output	These pins must be connected together externally. Bypass with a 4.7 μ F/10 V or higher to ground.
D2	CHGENB	Input	Charger Enable Logic Input	Logic-low to enable charger. Logic-high to disable the charger, not to disable buck converter. It has an internal 300 k Ω resistance to ground. If this pin is not used, leave it open or connect it to ground. The serial interface, I ² C, is still available in CHGENB = High.
D3	SHDNB	Input	Logic Input for Disabling I ² C Interface	If there is no valid input source, logic-low is to put the I ² C interface into Disabled mode to reduce the idle current as low as possible. In the Shutdown mode, I ² C interface is not available but the Q4 FET is kept ON. A valid power source on VBUS is able to overwrite to wake-up the device for Charge mode even in SHDNB = Low. This pin is not effective as long as a valid input power source is present. This pin has an internal pull-down resistance, 300 k Ω typ. If this pin is not used, tie it to the system I/O supply rail or an appropriate rail to reduce idle current as low as possible.
D4, E3, E4	VSYS	Output	System Supply Output	VSYS is the power supply for the system load. When a valid power source at VBUS is attached, VSYS is regulated at 3.6 V until the BATREG hits the threshold of $V_{SYS_MIN} \times R_{DS(on)_Q4}$. When the +Terminal on the battery cell is regulated at VBATREG, the VSYS output is regulated to the $I_{FAST_CHG} \times R_{DS(on)_Q4}$ above BATREG. Bypass with a 10 μ F/10 V ceramic capacitor to ground.
E1, E2	PGND	Ground	Power Ground for the Buck Converter	The two PGND pins must be connected together externally.

4 Electrical characteristics

4.1 Maximum ratings

Stress(es) beyond those listed under Absolute Maximum Ratings may cause permanent damage to the device. These are stress ratings only, and functional operation of the device at these or any other conditions beyond those indicated in the following operational sections of the specifications is not implied. Exposure to absolute maximum rating condition(s) for extended periods may affect device reliability.

Table 3. Maximum ratings

All voltages are with respect to ground unless otherwise noted.

Symbol	Rating	Min.	Max.	Unit	Notes
Electrical ratings					
	VBUS, PMID to GND	-0.3	20	V	(1)
	LX to GN	-0.3	20	V	(1)
	BOOT to LX	-0.3	5.5	V	(1)
	BOOT to GND	-0.3	25.5	V	
	PGND, BATSNSN to GND	-0.3	0.3	V	(1)
	VL to GND	-0.3	5.5	V	
	VSYS, CHGOUT, BATREG to GND	-0.3	Continuous 6.0	V	
	PGND to GND	-0.3	0.3	V	(1)
	All Other Pins to GND	-0.3	5.5		(1)
V_{ESD1} V_{ESD3}	ESD Voltage • Human Body Model (HBM) • Machine Model	— —	2000 200	V	(2) (3)

Thermal ratings

	Continuous Power Dissipation • $T_A \leq 25\text{ }^\circ\text{C}$ • $T_A \leq 70\text{ }^\circ\text{C}$ • $T_A \leq 85\text{ }^\circ\text{C}$	— — —	2.08 1.14 0.832	W	
T_A	Operating Temperature • Ambient	-40	85	$^\circ\text{C}$	
T_J	Maximum Temperature • Junction	—	150	$^\circ\text{C}$	
T_{STG}	Storage Ambient Temperature	-65	150	$^\circ\text{C}$	
T_{SOLDER}	Lead Soldering Temperature (within 10 s)	—	300	$^\circ\text{C}$	
$T_{\theta JA}$	Thermal Resistance Junction to Ambient	—	48	$^\circ\text{C}/\text{W}$	(4), (5)

Notes

1. GND: all of the PGND and GND should be within the limit.
2. Human Body Model (HBM) per JESD22-A114 for all pins
3. Highly depends on the PCB heat dissipation. Tested with the Thermal Characteristics test condition below.
4. $T_A = 70\text{ }^\circ\text{C}$
5. Measured in still air, free convection condition (conforms to EIA/JESD51-2) on high effective thermal conductivity JESD51-7 test board.

4.2 Electrical characteristics

Table 4. BC3770 electrical characteristics

Characteristics noted under conditions: $V_{VBUS} = 5.0\text{ V}$, $V_{BATREG} = 3.7\text{ V}$, $V_{VIO} = 1.8\text{ V}$, $C_{VBUS} = C_{PMID} = 2.2\text{ }\mu\text{F}$, $C_{VSY} = 10\text{ }\mu\text{F}$, $C_{CHGOUT} = 4.7\text{ }\mu\text{F}$, $C_{VL} = 1.0\text{ }\mu\text{F}$, $L = 1.0\text{ }\mu\text{H}$, $T_A = -40\text{ }^\circ\text{C to }85\text{ }^\circ\text{C}$ *). Typical values are at $T_A = 25\text{ }^\circ\text{C}$, unless otherwise noted. ⁽⁶⁾

Symbol	Characteristic	Min.	Typ.	Max.	Unit	Notes
VBUS supply						
V_{BUS_OP} V_{VIO_OP}	Operating Range <ul style="list-style-type: none"> On VBUS On VIO 	4.0 1.6	— —	6.2 3.3	V	
V_{BUS_UVLO}	UVLO Threshold <ul style="list-style-type: none"> VBUS rising, 200 mV Hysteresis, VBUSOK bit set to 1 	3.6	3.8	4.0	V	
V_{BUS_OVP}	OVP Threshold <ul style="list-style-type: none"> VBUS rising to turn off converter, 200 mV Hysteresis 	6.3	6.5	6.7	V	(7)
V_{AICL_TH}	Adaptive-Input Current Limit (AICL) Threshold Range <ul style="list-style-type: none"> VBUS falling, Programmable in 100 mV steps, 4.5 V Default 	4.3	—	4.9	V	
I_{VBUS_OP}	Adaptive-Input Current Limit (AICL) Threshold Range <ul style="list-style-type: none"> In charger enabled, $I_{FAST_CHG} = I_{SYS} = 0\text{ mA}$, SHDNB = H, SUSPEN = 0 LX No switching, $V_{VSY} = V_{BATREG} = 4.4\text{ V}$ override LX switching w/VSY = 3.7 V in PWM USB suspended mode in SUSPEN=1 	— — —	2.0 15 —	— — 1.0	mA	
I_{IN_LIM}	Input Current Limit Programmable Range <ul style="list-style-type: none"> 500 mA default, test 100 mA, 500 mA, 900 mA and 1.9 A only in production 	100	—	2050	mA	
	IIN_LIM Accuracy <ul style="list-style-type: none"> With respect to $I_{IN_LIM} = 100\text{ mA}$ With respect to $I_{IN_LIM} = 500\text{ mA}$ With respect to $I_{IN_LIM} = 900\text{ mA}$ With respect to $I_{IN_LIM} = 2000\text{ mA}$ 	70 70 84 93	85 85 92 100	100 100 100 107	%	(7)
	VBUS Pull-down Resistance <ul style="list-style-type: none"> Off in BOOST Mode 	—	100	—	k Ω	
VL LDO regulator						
V_{OUT_VLLDO}	Output Voltage <ul style="list-style-type: none"> $V_{PMID} = 5.0\text{ V}$, $I_{LOAD} = 30\text{ mA}$ 	4.65	4.8	—	V	
I_{LOAD_LIM}	Current Limit <ul style="list-style-type: none"> $V_{VLLDO} = 3.8\text{ V}$ 	50	—	—	mA	(7)
Switching regulator						
f_{SW}	Switching Frequency <ul style="list-style-type: none"> In PWM mode 	1.35	1.5	1.65	MHz	(7)
D_{MAX}	Maximum Duty Cycle	—	—	99	%	
D_{MIN}	Minimum Duty Cycle	0.0	—	—	%	
I_{LIM_CHG}	Cycle-by-cycle Current Limit for Charger Mode <ul style="list-style-type: none"> For high-side MOSFET in charger mode 	—	3.5	4.7	A	(7)
	Minimum Output Capacitance <ul style="list-style-type: none"> For stability 	-30%	10	—	μF	(7)

Notes

- Specifications over the T_A range are assured by design, characterized, and correlated with process control.
- Guaranteed by design, characterization, and correlation with process controls. Not fully tested in production.

Table 4. BC3770 electrical characteristics (continued)

Characteristics noted under conditions: $V_{VBUS} = 5.0\text{ V}$, $V_{BATREG} = 3.7\text{ V}$, $V_{VIO} = 1.8\text{ V}$, $C_{VBUS} = C_{PMID} = 2.2\text{ }\mu\text{F}$, $C_{VSY} = 10\text{ }\mu\text{F}$, $C_{CHGOUT} = 4.7\text{ }\mu\text{F}$, $C_{VL} = 1.0\text{ }\mu\text{F}$, $L = 1.0\text{ }\mu\text{H}$, $T_A = -40\text{ }^\circ\text{C to }85\text{ }^\circ\text{C}$ *). Typical values are at $T_A = 25\text{ }^\circ\text{C}$, unless otherwise noted. ⁽⁶⁾

Symbol	Characteristic	Min.	Typ.	Max.	Unit	Notes
Power switches						
$R_{DS(on)_Q1}$	Reverse Blocking MOSFET On-resistance • Q1 FET	—	50	—	m Ω	
$R_{DS(on)_Q2}$	Internal High-side MOSFET On-resistance • Q2 FET	—	50	—	m Ω	
$R_{DS(on)_Q3}$	Internal Low-side MOSFET On-resistance • Q3 FET	—	70	—	m Ω	
$R_{DS(on)_Q4}$	CHGOUT to VSY MOSFET On-resistance • Q4 FET	—	30	—	m Ω	

VSY output

V_{VSY_MIN}	VSY Min. Regulation Voltage in $I_{IN_LIM} \geq I_{VSY}$ • In both Trickle and pre-charge mode ($V_{BATREG} < V_{VSY_MIN}$), $I_{VSY} = 500\text{ mA}$	3.5	3.6	3.71	V	
$V_{VSY_MIN_OLP}$	VSY Min Regulation Voltage in $I_{IN_LIM} < I_{VSY}$ (VSY overloaded) • VSY falling in VSY overloaded in $VBUSOK = 1$	3.3	3.4	—	V	
V_{VSY_MAX}	SYS Max Regulation Voltage • In $VBUSOK = 1$, $I_{SYS_LOAD} = 0\text{ mA}$, $I_{CHG} = 1.5\text{ A}$	—	$V_{BATREG} + I_{CHG} \cdot R_{DS(on)_Q4}$	$V_{BATREG} + 0.1\text{ V}$	V	
	VSY SOK Threshold • VSY rising in $VBUSOK = 1$, VSY SOK bit set to 1	3.4	3.5	3.61	V	(8)
	VSY SNG Threshold • VSY falling, VSY SNG bit set to 1	3.2	3.3	—	V	(8)
$V_{VSY_REVERSE}$	Ideal Diode Regulation Voltage • VSY falling below BATREG, $I_{SYS_LOAD} = 3.0\text{ A}$	—	$V_{BATREG} - 50\text{ mV}$	$V_{BATREG} - 75\text{ mV}$	V	(8)
ΔV_{VSY_LOAD}	Load Regulation in Transition • $I_{VSY} = 1.0\text{ mA to }1.0\text{ A}$ in $t_R = 20\text{ }\mu\text{s}$	$V_{BATREG} - 0.2$	$V_{BATREG} - 0.1$	—	V	(8)
V_{VSY_UVLO}	VSY Undervoltage Lockout Threshold • VSY falling, 200 mV Hysteresis	2.3	2.4	2.5	V	
t_{DIODE_ON}	Ideal Diode Turn-on Time	—	10	—	μs	
t_{DIODE_OFF}	Ideal Diode Turn-off Time	—	10	—	μs	

Battery charger

V_{BATREG_RNG}	BATREG Programmable Voltage Range • Programmable in 25 mV steps	4.1	—	4.475	V	
V_{BAT_REG}	Voltage Accuracy • $I_{FAST_CHG} = 0\text{ mA}$, set to 4.2 V and 4.35 V at V_{BATREG} $T_A = 25\text{ }^\circ\text{C}$ $T_A = -40\text{ to }85\text{ }^\circ\text{C}$	-0.5 -1.0	— —	0.5 1.0	%	
V_{RCH}	Recharge Threshold • $V_{BATREG} - V_{BAT_REG}$	—	-100	—	mV	

Notes

8. Guaranteed by design, characterization, and correlation with process controls. Not fully tested in production.
9. Designed and simulated according to I²C specifications except general call support.
10. The regulation in boost is only guaranteed in the operation range.

Table 4. BC3770 electrical characteristics (continued)

Characteristics noted under conditions: $V_{VBUS} = 5.0\text{ V}$, $V_{BATREG} = 3.7\text{ V}$, $V_{VIO} = 1.8\text{ V}$, $C_{VBUS} = C_{PMID} = 2.2\text{ }\mu\text{F}$, $C_{VSY} = 10\text{ }\mu\text{F}$, $C_{CHGOUT} = 4.7\text{ }\mu\text{F}$, $C_{VL} = 1.0\text{ }\mu\text{F}$, $L = 1.0\text{ }\mu\text{H}$, $T_A = -40\text{ }^\circ\text{C}$ to $85\text{ }^\circ\text{C}$ *). Typical values are at $T_A = 25\text{ }^\circ\text{C}$, unless otherwise noted. ⁽⁶⁾

Symbol	Characteristic	Min.	Typ.	Max.	Unit	Notes
Battery charger (continued)						
I_{BAT_STD}	Stand-By Current • No VBUS, $V_{BATREG} = 4.2\text{ V}$, $I_{SYS} = 0\text{ mA}$, SHDNB = H (I^2C active), Q4 = On with OCP enabled, ENCOMPparator bit reset to 0, others with default	—	60	—	μA	
I_{BAT_SHDN}	Shutdown Current • No VBUS, $V_{BATREG} = 4.2\text{ V}$, charger disabled, Q4 = On with OCP disabled, SHDNB = L (I^2C inactive), ENCOMPparator bit reset to 0, others with default	—	—	20	μA	
V_{CHGEN_ON} V_{CHGEN_OFF}	Charger Enable Threshold • $V_{BUS} - V_{BATREG}$, rising, valid VBUS detected to enable buck & charging • $V_{BUS} - V_{BATREG}$, falling, invalid VBUS detection to disable buck & charging	100 0.0	150 50	200 —	mV	(11)
$V_{TRICKLE}$	Trickle to Pre-charge Mode Change Threshold • V_{BATREG} rising, 100 mV Hysteresis	2.4	2.5	2.7	V	(11)
$I_{TRICKLE}$	Trickle Charge Current • Fixed, $V_{BATREG} = 2.3\text{ V}$, $V_{SYS} = 3.6\text{ V}$	—	90	—	mA	
I_{PRECHG}	Pre-charge Current Programmable Range • 450 mA default and test in production	150	—	450	mA	
I_{FAST_CHG}	Fast-charge Current Programmable Range • 500 mA default, test 500 mA, 1.0 A only in production	100	—	2000	mA	
I_{TOPOFF}	Top-off Current Programmable Range • I_{FAST_CHG} falling, 100 mA default, in 50 mA steps, test 100 mA and 300 mA only in production	100	—	65	mA	
V_{BAT_OVP}	Overvoltage Protection Threshold • BATREG rising	—	$V_{BAT_REG} + 0.1$	—	V	
	Soft-start Slope Time • In fast charge mode	—	1.17	—	mA/ μs	
	Minimum Output Capacitance • On CHGOUT, For stability	-30%	4.7	—	μF	(11)
	Charge Current Accuracy • Pre-charge current at 150 mA • Top-off current at 100 mA • $I_{FAST_CHG} = 1000\text{ mA}$ • $I_{FAST_CHG} = 2000\text{ mA}$	-20 -20 -7.0 -7.0	— — — —	20 20 7.0 7.0	%	(11)

Thermal protection

T_{SD}	Thermal Shutdown Temperature • Temperature rising to shutdown with 20 °C hysteresis	—	150	—	°C	(11)
T_{CF}	Thermal Regulation Threshold • Rising, charge current starts to reduce and the Interrupt triggered	—	100	—	°C	
	Thermal Regulation Gain • To have no charge current with respect to I_{FAST_CHG} , $T_J \geq 100\text{ }^\circ\text{C}$	—	3.33	—	%/°C	

Notes

11. Guaranteed by design, characterization, and correlation with process controls. Not fully tested in production.

Table 4. BC3770 electrical characteristics (continued)

Characteristics noted under conditions: $V_{VBUS} = 5.0\text{ V}$, $V_{BATREG} = 3.7\text{ V}$, $V_{VIO} = 1.8\text{ V}$, $C_{VBUS} = C_{PMID} = 2.2\text{ }\mu\text{F}$, $C_{VSY} = 10\text{ }\mu\text{F}$, $C_{CHGOUT} = 4.7\text{ }\mu\text{F}$, $C_{VL} = 1.0\text{ }\mu\text{F}$, $L = 1.0\text{ }\mu\text{H}$, $T_A = -40\text{ }^\circ\text{C to }85\text{ }^\circ\text{C}$ *). Typical values are at $T_A = 25\text{ }^\circ\text{C}$, unless otherwise noted. ⁽⁶⁾

Symbol	Characteristic	Min.	Typ.	Max.	Unit	Notes
Safety timer						
t_{PRECHG_TMR}	Pre-charge Timer <ul style="list-style-type: none"> Time for BAT from $V_{TRICKLE}$ to V_{SYS_MIN} 	—	45	—	min.	
	Timer Accuracy	-10	—	10	%	(12)
t_{TOPOFF_TMR}	Top-off Timer <ul style="list-style-type: none"> Programmable 	10	—	45	min.	
t_{FAST_TMR}	Fast Charge Timer <ul style="list-style-type: none"> This timer is automatically disabled when the input current limit is set to 100 mA FASTTIME = 00 FASTTIME = 01 FASTTIME = 10 FASTTIME = 11 (default) 	—	3.5	—	hrs.	
		—	4.5	—		
		—	5.5	—		
		—	disabled	—		
Deglitch timer ⁽¹²⁾						
t_{VBUS_OVP}	VBUS Supply OVP Release Deglitch Time <ul style="list-style-type: none"> Duration VBUS stays below falling OVP before V_{SYS}/Charger/OTG is enabled 	—	0.426	—	ms	
t_{NOBAT}	NOBAT Release Deglitch Time <ul style="list-style-type: none"> Duration V_{NOBAT} stays logic low to enable the charger 	—	1.0	—	ms	
t_{BATOVP}	BATREG OVP Release Deglitch Time <ul style="list-style-type: none"> Duration BATREG stays below falling OVP level to enable charger/OTG 	—	7.0	—	ms	
$t_{TRICKLE}$	Trickle to Pre-charge Release Deglitch Time <ul style="list-style-type: none"> Duration BATREG stays above trickle charge level to enable pre-charge 	—	7.0	—	ms	
t_{PRCHG}	Pre-charge to Fast Charge Release Deglitch Time <ul style="list-style-type: none"> Duration BATREG stays above pre-charge level to enable fast charge 	—	7.0	—	ms	
t_{TOPOFF}	Top-Off Deglitch Time <ul style="list-style-type: none"> Duration I_{FAST_CHG} stays below Top-off level to generate an interrupt 	—	7.0	—	ms	
t_{BAT_RECHG}	Recharge Deglitch Time <ul style="list-style-type: none"> Duration V_{BATREG} stays below the V_{RCH} Threshold 	—	27	—	ms	
t_{WAIT}	Waiting Time to Initiate Trickle Charge Mode <ul style="list-style-type: none"> From t_{START_VSY} expire to initiate trickle charge 	—	27	—	ms	(12)
t_{WEAK_DEB}	Weak Battery Deglitch Time <ul style="list-style-type: none"> Duration V_{BATREG} stays below V_{WEAK_HYS} in ENCOMPARATOR bit = 1 	—	27	—	ms	
t_{START_VSY}	VSY Start-up Time <ul style="list-style-type: none"> From VBUS stays above UVLO to VSY start-up 	—	220	—	ms	
t_{INT_MASK}	Interrupt Mask Time	—	10	—	μs	
t_{TOPOFF}	Overcurrent Discharge Deglitch Time <ul style="list-style-type: none"> Duration I_{FAST_DISCHG} stays above the overcurrent threshold in Discharge mode to generate an interrupt 	—	7.0	—	ms	

Notes

12. Guaranteed by design, characterization, and correlation with process controls. Not fully tested in production.

Table 4. BC3770 electrical characteristics (continued)

Characteristics noted under conditions: $V_{VBUS} = 5.0\text{ V}$, $V_{BATREG} = 3.7\text{ V}$, $V_{VIO} = 1.8\text{ V}$, $C_{VBUS} = C_{PMID} = 2.2\text{ }\mu\text{F}$, $C_{VSYs} = 10\text{ }\mu\text{F}$, $C_{CHGOUT} = 4.7\text{ }\mu\text{F}$, $C_{VL} = 1.0\text{ }\mu\text{F}$, $L = 1.0\text{ }\mu\text{H}$, $T_A = -40\text{ }^\circ\text{C to }85\text{ }^\circ\text{C}$ *). Typical values are at $T_A = 25\text{ }^\circ\text{C}$, unless otherwise noted. ⁽⁶⁾

Symbol	Characteristic	Min.	Typ.	Max.	Unit	Notes
--------	----------------	------	------	------	------	-------

Deglitch timer ⁽¹²⁾ (continued)

t_{VSYsOK_DEB}	VSYSOK Deglitch Time • Duration VSYS stays above 3.6 V to set the VSYSOK interrupt bit = 1 and pull the INTB pin Low in VBUSOK = ENCOMPparator = 1	—	27	—	ms	
t_{VSYsNG_DEB}	VSYSNG Deglitch Time • Duration VSYS stays at/below the $V_{VSYs_MIN_OLP}$ threshold to set the VSYSNG interrupt bit = 1 and pull the INTB pin Low in Discharge mode and ENCOMPparator = 1	—	27	—	ms	
$t_{VSYsOLP_DEB}$	VSYSOLP Deglitch Time • Duration VSYS stays at/below the $V_{VSYs_MIN_OLP}$ threshold to set the VSYSOLP interrupt bit = 1 and pull the INTB pin Low in Overload mode and VBUSOK = 1	—	27	—	ms	

Boost converter

I_{S_OTG}	Boost Supply Current • In OTG enabled with no load	—	3.0	—	mA	
	Output Regulation Voltage Range • Programmable at PMID	5.0	—	5.2	V	
I_{LIM_OTG}	Cycle-by-Cycle Current Limit	—	2.4	—	A	
V_{BO_REG}	Boost Output Regulation Voltage at VBUS • $3.0\text{ V} \leq V_{BATREG} \leq 4.45\text{ V}$, set to 5.1 V at PMID, $0\text{ mA} \leq I_{LOAD} \leq 900\text{ mA}$	4.75	5.0	5.25	V	(13), (14)
I_{BO_MAX}	Maximum Continuous Output Current at VBUS • $3.0\text{ V} \leq V_{BATREG} \leq 4.45\text{ V}$	0.9	—	—	A	(13)
$V_{BAT_MAX_BO}$	Battery Operation Voltage Range • For the regulated output	3.0	—	4.45	V	(13)
V_{START_BO}	BATREG Start Threshold Voltage for Boost • V_{BATREG} rising	—	2.9	—	V	
V_{STOP_BO}	BATREG Stop Threshold Voltage for Boost • V_{BATREG} falling	—	2.5	—	V	
$V_{BUS_OVP_H}$	Overvoltage Protection at VBUS • VBUS rising, 400 mV Hysteresis	—	5.4	—	V	

INTB

	Output Low Voltage • $I_{SINK} = 5.0\text{ mA}$	—	—	0.4	V	
--	--	---	---	-----	---	--

Logic inputs (CHGENB, SHDNB, and NOBAT)

V_{IH}	Logic Input High Voltage	1.2	—	—	V	
V_{IL}	Logic Input Low Voltage	—	—	0.4	V	
R_{PD}	Pull-down Resistance to GND • On CHGENB & SHDNB pin	—	300	—	k Ω	
R_{PU}	Pull-up Resistance to VL • On NOBAT pin	—	300	—	k Ω	

Notes

13. Guaranteed by design, characterization, and correlation with process controls. Not fully tested in production.
14. The regulation in boost is only guaranteed in the operation range.

Table 4. BC3770 electrical characteristics (continued)

Characteristics noted under conditions: $V_{VBUS} = 5.0\text{ V}$, $V_{BATREG} = 3.7\text{ V}$, $V_{VIO} = 1.8\text{ V}$, $C_{VBUS} = C_{PMID} = 2.2\text{ }\mu\text{F}$, $C_{V_{SYS}} = 10\text{ }\mu\text{F}$, $C_{CHGOUT} = 4.7\text{ }\mu\text{F}$, $C_{V_L} = 1.0\text{ }\mu\text{F}$, $L = 1.0\text{ }\mu\text{H}$, $T_A = -40\text{ }^\circ\text{C to }85\text{ }^\circ\text{C}^*$). Typical values are at $T_A = 25\text{ }^\circ\text{C}$, unless otherwise noted. ⁽⁶⁾

Symbol	Characteristic	Min.	Typ.	Max.	Unit	Notes
Weak battery detection						
V_{WEAK_L}	Weak Battery Programmable Range • BATREG falling, programmable in 50 mV steps	3.0	—	3.75	V	
	Weak Battery Threshold Accuracy	-5.0	—	0.4	%	(15)
V_{WEAK_HYS}	Weak Battery Voltage Hysteresis • BATREG rising	—	100	—	mV	

I²C interface ^{(15), (16)}

V_{IH_I2C}	I ² C Logic Input High Threshold Voltage • SDA, SCL	1.2	—	—	V	
V_{IL_I2C}	I ² C Logic Input Low Threshold Voltage • SDA, SCL	—	—	0.4	V	
V_{OL_I2C}	I ² C Logic Output Low Voltage • SDA at 3.0 mA sink current	—	—	0.4	V	
f_{SCL}	SCL Clock Frequency	0.0	—	400	kHz	

Notes

15. Guaranteed by design, characterization, and correlation with process controls. Not fully tested in production.
 16. The regulation in boost is only guaranteed in the operation range.

5 Functional device operation

5.1 Introduction

The BC3770 is a fully programmable switching charger with a single-input for USB/DCP adapter and a dual-path output for single-cell Li-Ion and Li-Polymer batteries. The dual-path output allows mobile applications with a fully discharged or dead battery to boot up the system through the VSYS output. High-efficiency and switch-mode operation of the BC3770 reduce thermal dissipation and allows the battery to charge faster with a higher current capability. The BC3770 supports single input up to 20 V max. absolute voltage and charges the battery with the current up to 2.0 A. Owing to a high-efficiency in a wide range of input voltages and charging currents, the switch mode charger is a good choice for fast charging with less power loss and better thermal management than a linear charger. The charging parameters and operating modes are fully programmable over an I²C interface that operates up to 400 kHz in full speed. The BC3770 features a highly integrated synchronous switch-mode charger, intelligent power-path, VSYS stable control scheme in overload condition, and an automatic battery detection function. The charger and boost regulator circuit switches at 1.5 MHz, to minimize the size of external passive components.

To ensure USB compliance and minimize charging time, the input current is able to be limited to the value set through the I²C. The setting of charge top-off current is also programmable over I²C.

The BC3770 provides battery charging in four modes: trickle, pre-charge, fast charge (constant current), and full-charge (constant voltage). The charging restart circuit automatically restarts the fast-charge cycle in full-charge mode when the battery falls below an internal threshold over the deglitch time and detected top-off threshold. Input and charge status are reported to the processors through the interrupt pin, INTB. Charge current is reduced when the die temperature reaches 100 °C, while the system current is maintained. The BC3770 is able to operate as a boost regulator for USB-OTG devices over I²C.

5.2 Features

- Dual-path output to power-up system in dead battery
- Single Input for USB/TA
- High-efficiency synchronous switching regulator
- 20 V maximum withstanding input voltage
- Minimize the charging time with remote sense
- Up to 2.0 A load current for system or battery
- Programmable charge parameters via I²C compatible interface
 - Fast charge current
 - Charge termination current
 - Battery regulation voltage
 - Pre-charge current
 - Fast charge threshold voltage
 - Charge reduction threshold voltage
- 400 kHz full-speed I²C interface
- 1.5 MHz switching frequency
- Charge reduction mode for maximizing charging efficiency
- Protection
 - Thermal protection
 - Thermal regulation
 - Input/output overvoltage protection
 - Adaptive input current limit protection (AICL)
 - Reverse leakage protection
 - No battery detection over pin detection
 - Battery OVP protection
 - Overcurrent protection in discharge mode
- Boost mode operation for USB OTG
 - Output voltage: 5.0 V to 5.2 V, programmable at 900 mA

5.3 Operational modes

5.3.1 Undervoltage lockout (UVLO)

The BC3770 has a typical undervoltage lockout threshold of 3.8 V, with a 200 mV hysteresis, rising on VBUS. VSYS also has a falling 2.5 V typical with 200 mV hysteresis. When the input supply voltage is below the 3.6 V typical UVLO falling level, the PWM buck converter turns off.

5.3.2 Registers reset

All programmable registers in the device are reset to the default values when the following condition is met.

- Reset Condition: $VSYS \leq V_{SYS_UVLO}$

5.3.3 Q4 FET on in no valid VBUS

If the battery is connected with the voltage above a typical of 2.4 V and no any valid input power source is attached, the Q4 FET between VSYS and CHGOUT turns On and connects the Battery to the system, regardless of status of SHDNB. The VL regulator stays off.

5.3.4 Charge mode

The BC3770 performs the following pre-qualification process before initiating the Charging mode:

1. Input Voltage: Detect the validation of VBUS power source, charger enable threshold, and Adaptive-Input Current Limit (AICL) threshold. If the falling VBUS hits the AICL threshold, the charging current is reduced to limit the amount of drop on VBUS power source. In addition, the device senses the input voltage is at least above BATREG + 150 mV.
2. Battery Presence Detection: Detect the status of battery presence through the NOBAT pin. If the voltage on the NOBAT pin is above the logic high threshold, the charging is suspended (Internal Q4 FET is open). However, VSYS is regulated at VVSYS_MAX as long as a valid input source is attached.
3. Battery Voltage: Sense the battery voltage if it is less than the BAT OVP threshold.
4. Die Temperature: If the die temperature is above 130 °C or less than 150 °C, charging is suspended.
5. Overvoltage Detection (OVP): Sense if the VBUS is less than the OVP threshold. If the OVP condition is detected, the PWM converter is immediately shut off.
6. Validation of Software and Hardware Enable signals: Detect the status of software enable bit, CHGEN=1, SUSPEN=0, and hardware pin of CHGENB=LOW.

This pre-qualification process is continuously monitored and charging is suspended until all conditions are met.

5.3.5 Charging profile

5.3.5.1 Trickle-charge mode

Trickle-charge mode is automatically enabled in 27 ms after the VSYS start-up time expires. The battery is charged with a fixed 90 mA charge current until the battery voltage reaches the threshold, 2.5 V typical in rising. This threshold is not programmable over I²C. As soon as the battery voltage crosses over the threshold, a pre-charge mode is activated automatically after the fixed deglitch time. This allows the protection circuit in the battery pack to be reset with no damage, and brings the battery voltage to a higher level.

5.3.5.2 Pre-charge mode

The Pre-charge mode is enabled in $t_{TRICKLE}$ when the battery voltage crosses over a typical 2.5 V. The safety timer called pre-charge timer, t_{PRECHG_TMR} , 45-minute counts at the same time as well. This timer is reset as soon as the Fast-charge mode is initiated. This allows a deeply discharged battery to charge safely. The pre-charge current is programmable from 150 mA to 450 mA in 100 mA steps over I²C. If the battery voltage does not exceed the V_{VSYS_MIN} threshold before the timer expires, charging is suspended and a fault signal is asserted via the INTB pin. If the VSYS voltage drops due to the limited input power source during the mode, the charge current is automatically reduce to maintain the VSYS as low as at 3.4 V. If the load is still overloaded, even in no charge current and limited input current, the VSYS can't help the collapse.

5.3.5.3 Fast-charge mode (constant-current mode)

The Fast-charge mode is entered in t_{PRECHG} when the battery voltage exceeds the $V_{V_{SYS_MIN}}$ threshold of a typical 3.6 V. During this mode, the battery is charged with a programmable fast-charge current. The fast-charge current is programmable from 100 mA to 2000 mA with a 500 mA default. Fast-charge current is always limited by the input current limit setting. As soon as the battery voltage reaches the $V_{V_{SYS_MIN}}$ threshold, V_{SYS} tracks the battery voltage through the Q4. This is called "tracking mode". In tracking mode, power dissipation is minimized by $RDSON_Q4 \times I_{FAST_CHG}$. However, if the V_{SYS} voltage drops during the fast-charge mode, the charge current is automatically reduce to keep the dropout voltage, to ensure proper operation of charging circuitry. During this fast-charge mode, the safety timer called fast charge timer, t_{FAST_TMR} , counts. If the battery voltage does not reach the V_{BAT_REG} threshold before the timer expires, charging is suspended and a fault signal is asserted via the INTB pin. This timer is programmable and is disabled by default. This timer is automatically disabled when the input current limit is set to 100 mA.

5.3.5.4 Full-charge mode (constant-voltage mode)

As soon as the $BATREG$ voltage reaches the V_{BAT_REG} threshold, the fast-charge current is reduced to a programmable top-off current. The V_{BAT_REG} regulation threshold is programmable from 4.1 V to 4.475 V in 25 mV steps.

5.3.5.5 Top-off mode (constant-voltage mode)

If the charge current down to a pre-programmed top-off current threshold is sensed over t_{TOPOFF} , the safety timer called top-off timer, t_{TOPOFF_TMR} , 45-minute by default, automatically counts. The top-off interrupt event is reported to the processor via the INTB. As soon as the processor reads the interrupt registers, the processor is able to turn off the charger by either $CHGENB = H$, $CHGEN = 0$, or wait until the timer expires in $AUTOSTOP=1$. The top-off current is programmable from 100 mA to 650 mA in 50 mA steps. 100 mA is the default.

5.3.5.6 Done mode (constant-voltage mode)

After the top-off timer expires, the charger is Off automatically in $AUTOSTOP=1$. However, the charger stays at CV (Constant-voltage mode) in $AUTOSTOP=0$ even though the top-off timer expires. The interrupt signal of Done is reported to the processors via the INTB pin, regardless of the $AUTOSTOP$ status.

5.3.6 Boost (OTG) mode

Similar to Charge mode operation, in OTG mode enabled by I²C control bit, $ENBOOST = 1$, the device provides a regulated output voltage to $VBUS$ from the battery. In Boost mode, the device first converts the battery voltage to a target voltage at $PMID$, then bypasses it to the $VBUS$ pin with load current up to 900 mA to support USB OTG devices. In order to have a final regulated output at $VBUS$, the minimum input at $BATREG$ should be at least or above 3.0 V. To activate Boost mode, all of the following conditions should be met in advance.

1. Either the $CHGEN$ bit resets to "0" or $CHGENB = HIGH$ (meaning for "charger disabled")
2. The $VBUS$ voltage must be less than the $UVLO$ falling threshold
3. No Fault Conditions
4. $SUSPEN$ bit reset to "0"

Then set the $ENBOOST$ bit to "1". In this Boost mode, the following functions are consequently disabled.

- $AICL$
- Charging

5.3.6.1 Soft-start in Boost mode

When Boost mode is enabled, the $PMID$ is regulated to a pre-programmed voltage. After $PMID$ reaches a preset target regulation voltage, the FET between $PMID$ and $VBUS$ turns On slowly to minimize the inrush current. The output current limit is ramped up to the boost output current limit. This soft-start counter is not initialized when one of next conditions occur.

1. Die temperature exceeds T_{SD}
2. No battery detection ($NOBAT = H$) on $NOBAT$
3. Voltage on $VBUS$ rises over V_{BUS_OVP}
4. Voltage on the $BATREG$ pin rises over $V_{BAT_MAX_BO}$
5. Voltage on the $BATREG$ pin falls below V_{STOP_BO}

5.3.7 Battery recharge

Regardless of the AUTOSTOP bit status, the re-charge of the battery is able to be performed in two ways.

1. Automatic Enable

After a top-off threshold or Done is detected and the battery voltage drops below the recharge threshold, V_{RCH} , over the deglitch time, a typical of 27 ms, the charger automatically resumes the charging. In this mode, the interrupt signal of "recharge" is reported to a processor via the INTB pin. However if the battery voltage recovers above the threshold within 27 ms, the charging restart is not resumed and an interrupt event is not reported. The threshold is a fixed value of -100 mV.

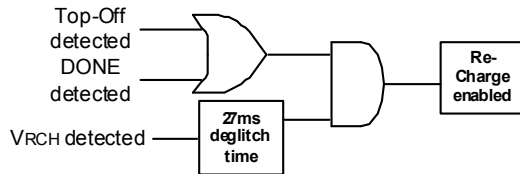

Figure 4. Re-charge enabled in the automatic way

2. Manual Enable

The Application Processor (AP) is able to turn off the charger after the top-off or Done state is detected. Once the charger is enabled by the processor and if the recharge conditions are met, the charger automatically charges the battery.

5.3.8 Soft-start

The BC3770 provides a soft-start in the transition from Pre-charge to Fast-charge mode to allow for a smaller voltage drop on VSYS and to prevent input current and voltage transients. However, there is no soft-start in recharge mode. In summary, the following is the typical charging profile where the following conditions are met in advance.

- A valid input is detected
- No AICL threshold detected
- All timers reset
- Input current limit > fast-charge current
- No SYS current
- Input current limit not detected
- No status changes on CHGEN = 1, CHGENB = LOW, SUSPEND = 0 and AUTOSTOP = 1
- $V_{RCH} = -100$ mV
- Related interrupt bits not masked
- Deep battery with 2.0 V attached in advance
- Deglitch time excluded

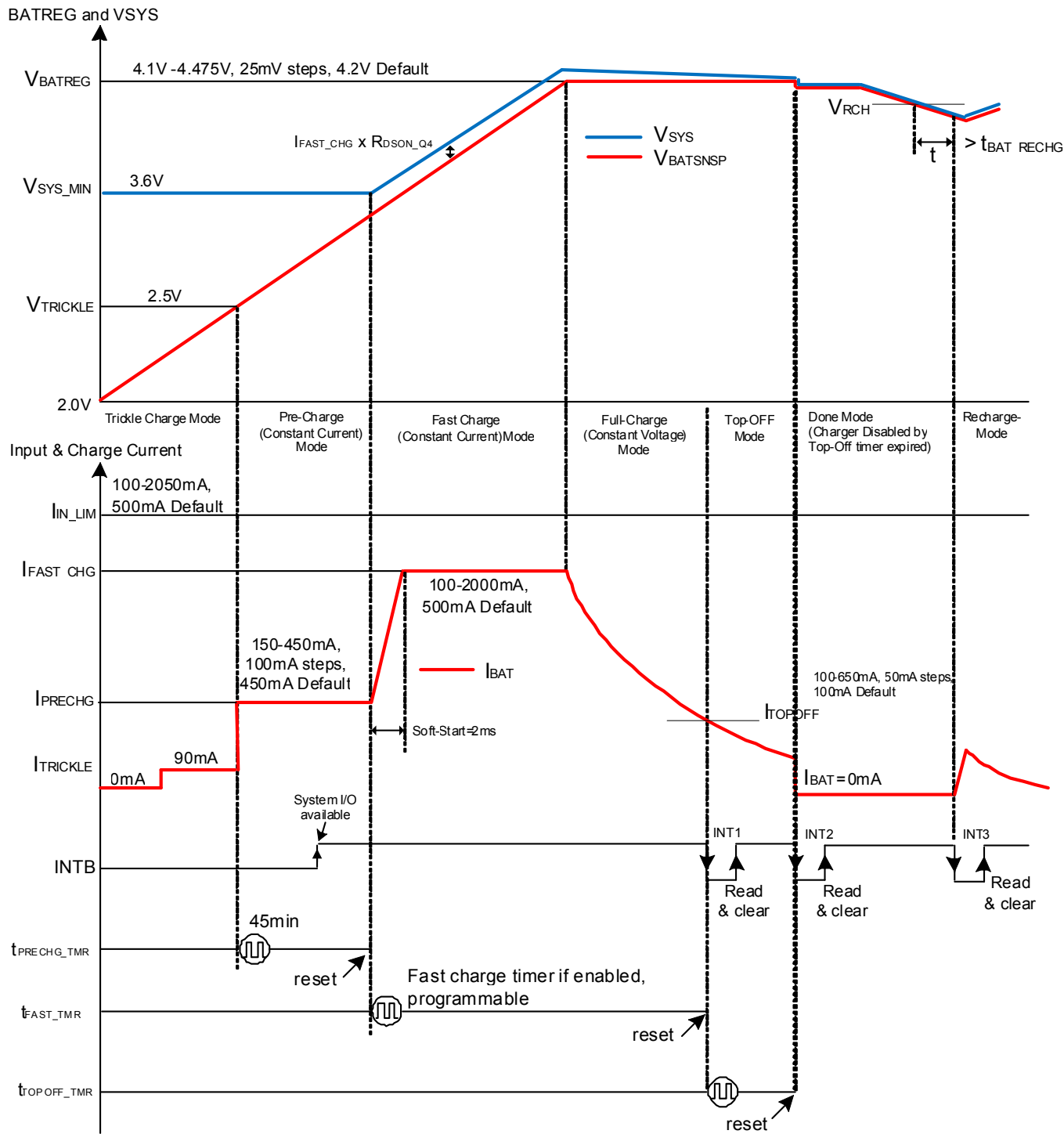

Note 1: INT1 for Top-Off Interrupt, INT2 for Done Interrupt, INT3 for Recharge Interrupt
 Note 2: The time of Read & Clear depends on the processor.
 Note 3: Each deglitch time is not included.
 Note 4: Charger restart condition is made on purpose to show the behavior.

Figure 5. Typical charging profile in no fault condition

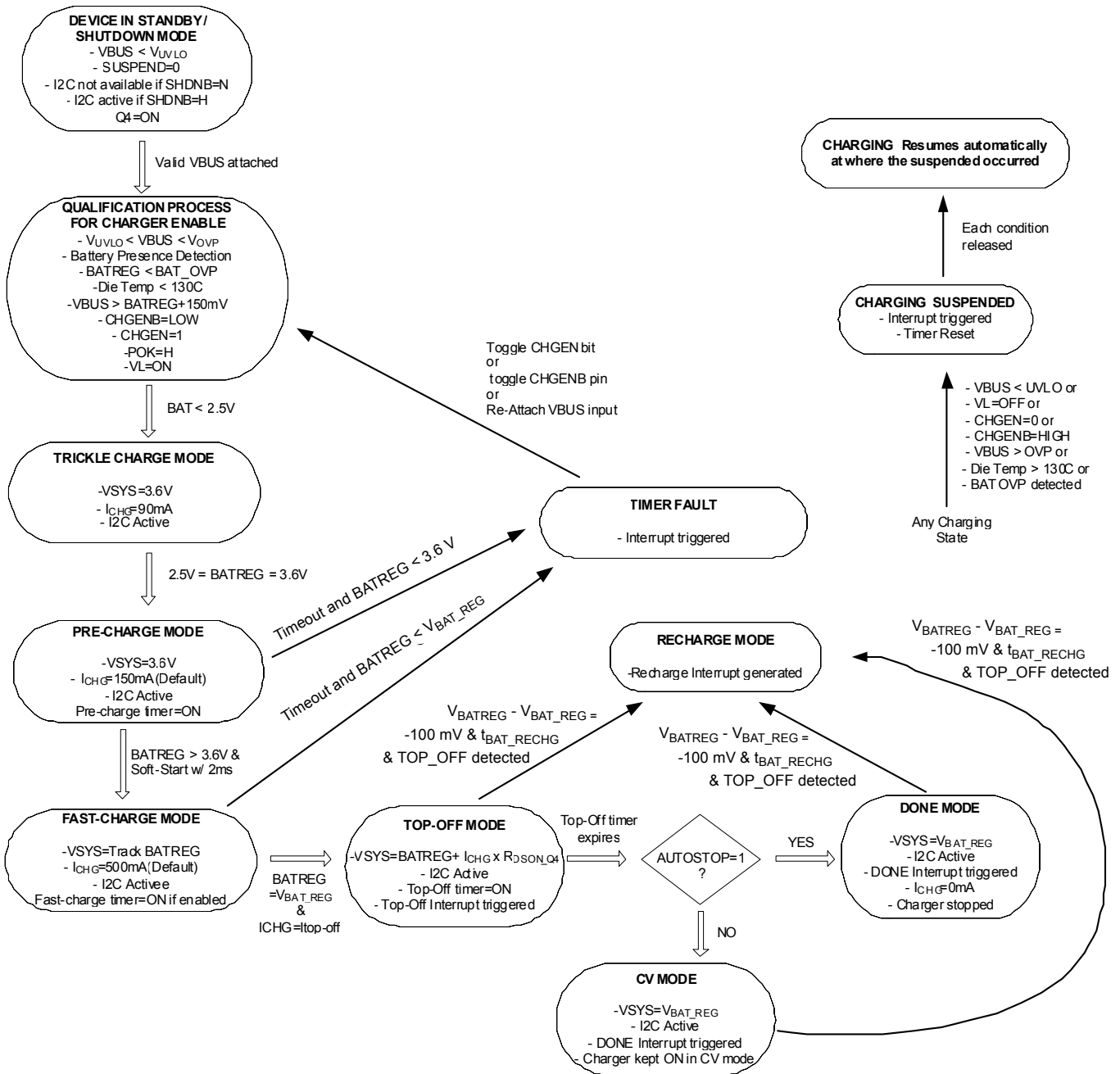

Figure 6. Charger state diagram

5.3.9 Safety timer

There are three safety timers on the device: a pre-charge timer, a fast charge timer, and a top-off timer. The pre-charge is fixed at 45 minutes, and the fast charge and the top-off timer are programmable over I²C. The reset conditions for each timer are described with the following.

1. Pre-charge timer is reset in one or more of the following ways:
 - BATREG crosses over the V_{SYSTMN} minimum threshold of 3.6 V
 - Falling V_{BUS} UVLO detected
 - CHGENB = HIGH
2. Fast-charge timer is reset in one or more of the following ways:
 - BATREG hits the regulation voltage V_{BAT_REG} and the charge current hits the top-off current threshold
 - Falling V_{BUS} UVLO detected
 - CHGENB=HIGH or CHGEN reset to “0” before expiration
3. Top-off timer is reset in one or more of the following ways:
 - BATREG hits the regulation voltage V_{BAT_REG}, the charge current hits the top-off current threshold, and the timer expires in AUTOSTOP = 1
 - Falling V_{BUS} UVLO detected
 - CHGENB = HIGH or CHGEN reset to “0” before expiration

However, all safety timers are reset commonly in the following fault conditions:

- BAT OVP detected
- V_{BUS} OVP detected
- Thermal shutdown

If all fault conditions are released, the timer resumes to start.

5.3.10 V_{SYSTMN}

When being charged from V_{BUS}, if the battery voltage becomes close to the minimum system voltage threshold, V_{SYSTMN} (3.6 V), V_{SYSTMN} tracks the battery voltage up to a preset V_{BAT_REG}. A load current from an input is provided to both V_{SYSTMN} and the battery with up to a maximum input limit programmed value.

The device regulates the system supply voltage, V_{SYSTMN} (3.6 V), in Trickle and Pre-charge mode, which allow the application system to be booted up even in dead or deeply discharged battery. The device has the system output, V_{SYSTMN}, priority over charge current, which gives the required load for the system while reducing the charge current, if the input current is limited. System path also allows accurate charge cycle since it allows the system to know precisely when the charging current has hit the current termination threshold vs. implementations, where the battery and the system are connected to the same node. When the battery voltage crosses the minimum system voltage threshold, V_{SYSTMN}, the V_{SYSTMN} tracks the battery voltage with an appropriate voltage differential by R_{DS_ONQ4} x charge current. This insures the minimum power dissipation on the device comes true. When the battery charging is completed, the system node, V_{SYSTMN}, is regulated to V_{BAT_REG} + R_{DS_ON} x charge current (if available). If the charge current becomes truly 0 mA, the V_{SYSTMN} is technically equal to the battery voltage.

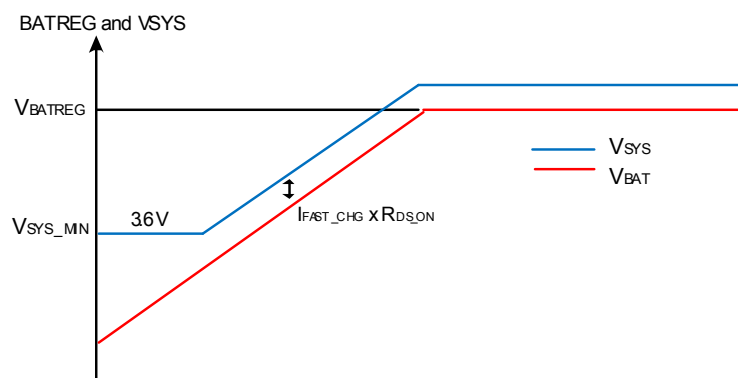

Figure 7. V_{SYSTMN} tracking BATREG

5.3.10.1 Charger enable control

The CHGEN bit in the control register and CHGENB pin are used to enable or disable the charging process.

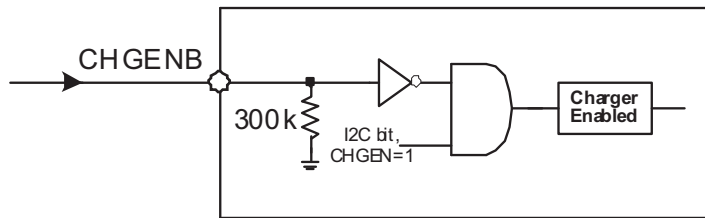

Figure 8. Charger enable

If the CHGENB pin is not used in the application, leave the pin float since CHGENB has an internal 300 kΩ pull-down resistance to ground.

5.3.10.2 Battery presence detection

The BC3770 monitors battery presence via the NOBAT pin in any condition. This function utilizes the pull-down resistor on VF in the battery pack. If no battery is detected, the charging is suspended immediately and the corresponding interrupt event is reported to the processor via the INTB pin. If the NOBAT pin needs to be connected to an ADC input on the main processor, a resistor-divided configuration in fig should be done to lower the voltage rating to 1.8 V.

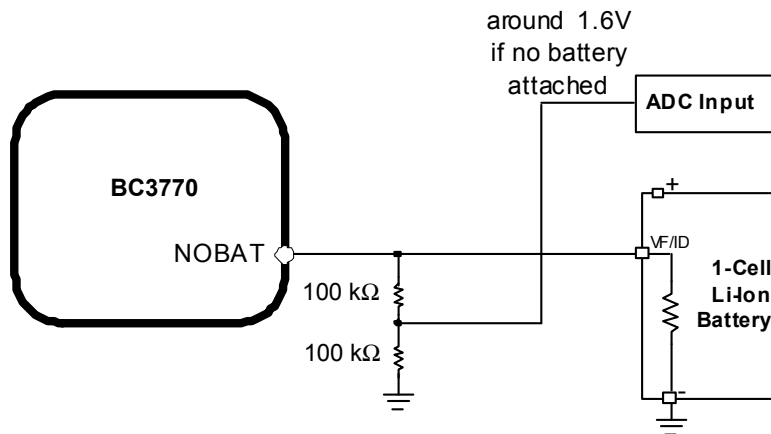

Figure 9. Resister divided network

If NOBAT is not used as a battery presence indicator, the following configuration is also possible.

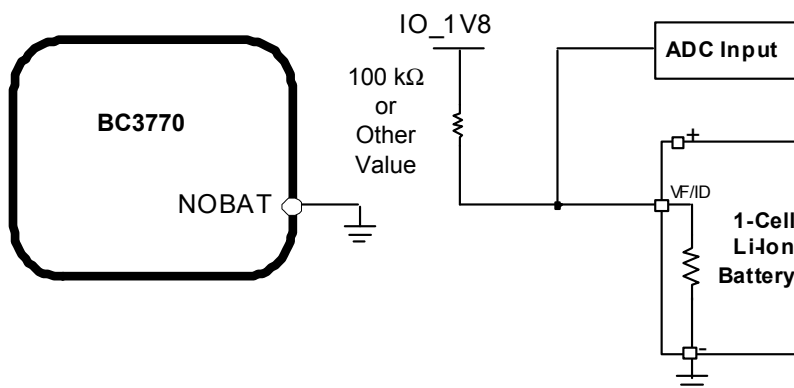

Figure 10. Resister divided network option

5.3.10.3 Battery remote sensing

In order for the device to exactly regulate the + terminal on the battery cell as close to a preset V_{BAT_REG} as possible, the BATREG and BATSNSN pins are used. In the real application, there may be some voltage drop between the CHGOUT pin and the + terminal, which comes from parasitic resistance, due to the PCB trace and a charge current. This voltage drop makes the V_{BAT_REG} not regulate at the target regulation voltage. To reduce the charging time, place those two pins, BATREG and BATSNSN, as close to each + and - terminal on the battery pack as possible.

5.3.10.4 Adaptive-input current limit (AICL)

The AICL function prevents the current limited input supply voltage from sagging below a certain preset AICL threshold voltage (V_{AICL_TH}). If the required input current of device for a certain programmed value of I_{IN_LIM} exceeds the maximum input current of the VBUS supply, then the VBUS supply will collapse and the device won't function properly under these conditions. To keep the device functional with a current and voltage limited VBUS source, the device in Start-up mode automatically starts incrementing the input current limit to either the default or pre-programmed value until either the input current limit is detected or the VBUS voltage detects the AICL threshold, to keep input supply voltage as a valid power source to provide the load for the application. The device allows the maximum current the input supply can possibly provide without severely collapsing.

In general, the AICL function is enabled whenever the input current tries to exceed the input current limit, while charging the battery and/or providing the system load. At the beginning of the charge cycle with discharged battery, the required input current could be lower than the VBUS current limit. The input current increases as the battery voltage increases. Eventually, the input current may exceed the VBUS input current limit. If this happens, the AICL function takes over and lowers the charge current below the programmed value to keep VBUS around V_{AICL_TH} .

Most of the time charge reduction occurs at the beginning of charge cycle when a low current limited AC adapter or USB port is connected as a valid input source. During start-up the device detects the current limited supply by slowly stepping up the input current with a programmable soft-start clock period. Each current step is around 25 mA. As the charge and system current are stepped up, the input current also steps up in staircase fashion. Eventually, the input current will hit the current limit. The input falls to or below V_{AICL_TH} . When this happens, the device steps down the input current by 25 mA at the next clock rising edge. This allows the input supply voltage to rise above V_{AICL_TH} at the next soft start clock cycle. The charge current is stepped up again by 25 mA. This again allows the input current to be exceeded. The input reduction continues to step up and down the input current by 25 mA to maintain the input supply voltage as close to V_{AICL_TH} as possible.

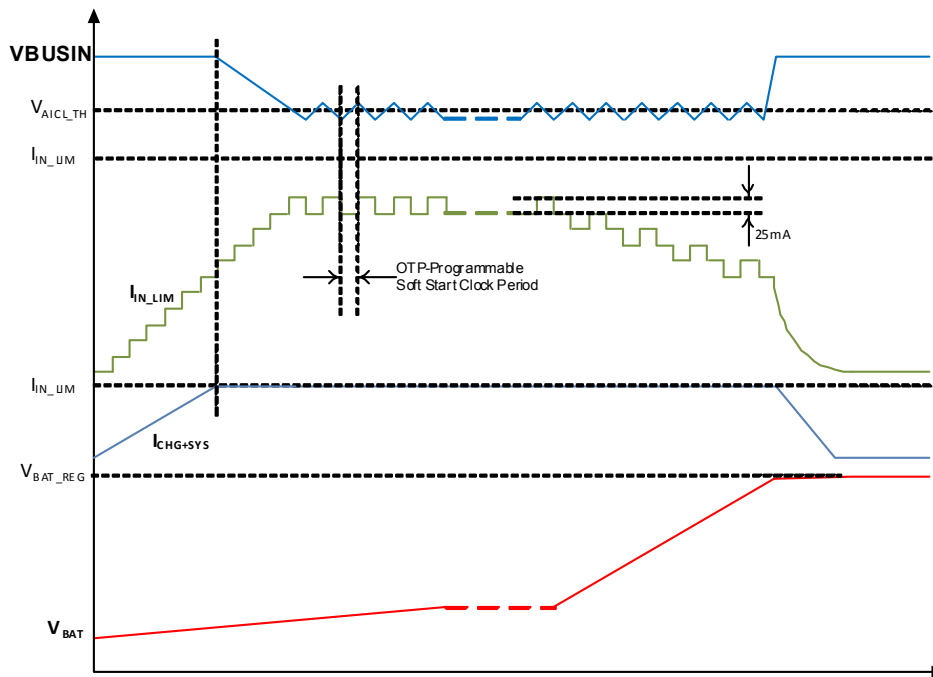

Figure 11. AICL operation

5.3.10.5 Supplement mode

When the VSYS voltage falls below the battery voltage while a valid input is attached, the Q4 FET turns On and the Q4 FET gate regulates the gate drive of Q4 so the minimum VSYS stays at 50 mV below BATREG in the Supplement mode. This prevents oscillation from entering and exiting Supplement mode. As the discharge current increases, the Q4 gate is regulated with a higher voltage, to reduce $R_{DS(on)}$ until Q4 is full conduction.

5.3.10.6 Charging current reduction in VSYS overload

When the input current limit is detected in Charge mode by either a system overload or a programmed value is lower than the sum of load current and charge current, the device reduces the charge current until the limited input current falls below the preset current limit threshold, and the input voltage rises above the input voltage limit while maintaining the VSYS voltage at 3.4 V.

Although the charge current is reduced to 0 mA, the input power source is still overloaded, and the system voltage starts to drop. Once the system voltage falls 50 mV below the battery voltage, the device automatically enters the Supplement mode and the battery starts discharging so the system is supported from the both the input supply and battery. An corresponding interrupt for VSYS overload triggers via the INTB pin.

5.4 Protection and diagnosis features

5.4.1 Input overvoltage protection

When the input voltage exceeds the overvoltage protection (OVP) threshold, internal switches immediately turn off and disconnect the load and the charger from the power source, preventing damage to any downstream components. Simultaneously, the fault flag is triggered, alerting the system. As soon as the OVP event stays over the deglitch time, t_{INPUT_OVP} , the converter resumes.

5.4.2 Battery (BAT) overvoltage protection

When the BATREG voltage exceeds the battery overvoltage protection threshold, V_{BAT_OVP} (typ. $V_{BAT_REG} + 0.1$ V), the device turns off the PWM converter and sets the fault status bit. Simultaneously, the fault flag is asserted, alerting the system. There is a 0.1 V hysteresis in the internal threshold voltage. If the OVP event over the deglitch time is released, the converter and charging resume.

5.4.3 Reverse blocking

In the reverse blocking mode ($V_{BUS} - V_{BATREG} \leq 50$ mV (typ.)), charging is disabled and the device is entered into Charger-suspended mode to minimize current drain from BATREG.

5.4.4 Thermal regulation and protection

When the device's die temperature reaches T_{CF} (around 100 °C), the device reduces the charge current by around 3.33% of the fast-charge current per °C. This drives the charge current down to 0 mA at 130 °C. Since the system load has priority over the battery charging, the battery charge current is reduced to 0 mA before the input limiter drops the system load current. If the junction temperature rises beyond 130 °C and then hits 150 °C, the PWM switcher shuts down to allow no input current from the input source. This prevents further die heating. In this condition, the system output voltage is regulated at BATREG. This internal thermal protection helps to improve device reliability. The device automatically goes back to normal operation when the die temperature cools down below 130 °C. In these thermal regulation and shutdown modes, I²C access is still active.

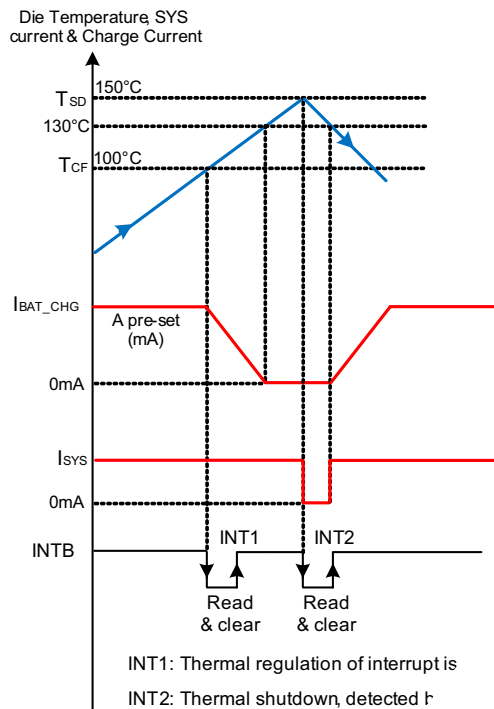

Figure 12. Thermal regulation

5.4.5 Weak battery detection

A weak battery detection function allows the processor to acknowledge the low-battery condition. To prevent false voltage transients from interrupting the processor unnecessarily, the out-of-range condition must stay at least for the deglitch time of 27 ms, before an interrupt is generated. If the battery voltage goes back in range before the deglitch time, no corresponding interrupt is generated.

5.4.6 DC-DC PWM converter

The device features an integrated fixed 1.5 MHz frequency. The device uses a peak current mode PWM controller to regulate the output voltage and battery charge current. The low-side FET (Q3) also has a current limit that decides if the PWM controller can operate in boost mode. The threshold is set to 100 mA and turns off the high-side N-channel FET (Q2) before the current reverses, preventing the battery from discharging.

5.4.7 Interrupt

The device uses the Interrupt pin, INTB, to indicate if the status on the device has changed. The Interrupt is asserted whenever one or more interrupt events are detected in its operation. The processor reads the interrupt registers to see the source of interrupt event(s). Interrupt bit(s) is (are) only cleared by reading all or some corresponding bits in the interrupt registers. If an interrupt bit is masked in an interrupt event, the corresponding interrupt bit is still set to 1 in the corresponding register. However, the INTB interrupt pin is not asserted to low. When the corresponding mask bit is set to “0” because of an earlier interrupt event, the interrupt pin for the corresponding interrupt event is asserted low to alert the processor after the t_{INT_MASK} delay time, typically 10 μ s. If the abnormal condition continues after the processor reads a corresponding interrupt bit, the corresponding interrupt bit is no longer set to “1”.

5.4.7.1 Comparators for interrupt events

To save the idle current in Stand-by or Shutdown mode, the internal comparators that detects “Weak Battery” status, “VSYSOK or NG” status, the “Battery OVP” status and “Discharge Limit” status are capable of being disabled over the I²C interface by resetting the “ENCOMPARATOR” bit 6 to 0 in the 07h register. The comparators are enabled by default.

If the comparators are disabled in “no valid supply” on VBUS, the VBUSOK signal overrides the bit set to 1 by force, to detect weak battery detection, VSYSOK or NG detection, and BATOVP detection. This wakes up the comparators to notify the application processor of these interrupt events.

5.5 Logic commands and registers

5.5.1 Serial interface

I²C is a two-wire serial interface developed by Phillips Semiconductor. The bus consists of a data line, SDA, and a clock line, SCL, with pull-up structures. When the bus is idle, both the SDA and SCL lines are pulled high. All the I²C compatible devices connect to the I²C bus through open drain I/O pins, SDA, and SCL. A master generates the clock signal and device addresses. The master also generates specific conditions that indicate the START and STOP of data transfer. A slave device receives and/or transmits data on the bus under the master device.

The device works as a slave and is compatible with the following data transfer modes, as defined in the I²C-Bus Specification: Standard mode (100 kbps) and Fast mode (400 kbps). The interface adds flexibility to all necessary control options of the program, and enables most functions to be programmed to the new values, depending on the instantaneous application requirements. I²C is asynchronous, which means that it runs off of SCL. The data transfer protocol for Standard and Fast modes is exactly the same.

5.5.1.1 Bus speed

The device I²C interface supports bus SCL clock speeds up to 400 kbps for Full-speed mode. The SCL and SDA input buffers incorporate spike suppression and Schmitt triggers to reject short glitches, as required by the I²C specifications.

5.5.1.2 Data validity

During all transmissions, the master ensures the data is valid. A valid data condition requires the SDA line to be stable during the High period of the clock (see Figure 13). The High or Low state of the data line can only change when the clock signal on the SCL line is Low (see Figure 1). One clock pulse is generated for each data bit transferred.

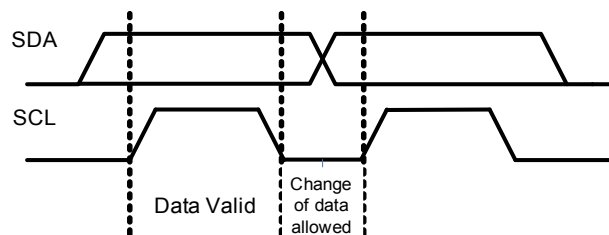

Figure 13. Bit transfer on the I²C bus

5.5.1.3 Start and stop condition

All transactions begin with a START (S) and can be terminated by a STOP (P) (see Figure 2). A High to Low transition on the SDA line while SCL is High defines a START condition. A Low to High transition on the SDA line while SCL is High defines a STOP condition.

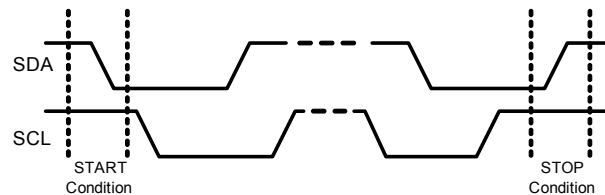

Figure 14. START and STOP conditions

START and STOP conditions are always generated by the master. The bus is considered to be busy after a START condition. The bus is considered to be free again a certain time after the STOP condition.

5.5.1.4 Byte format

Every byte put on the SDA line must be eight bits long. The number of bytes that can be transmitted per transfer is unrestricted. Each byte has to be followed by an acknowledge bit. Data is transferred with the Most Significant Bit (MSB) first. If a slave cannot receive or transmit by servicing an internal interrupt, it can hold the clock line SCL Low to force the master into a wait state. Data transfer then continues when the slave is ready for another byte of data and releases clock line SCL.

5.5.1.5 Acknowledge (ACK) and not acknowledge (NACK)

The acknowledge bit is used for handshaking purpose between the master and slave. The master and slave both can either receive or send eight bits of serial data, depending on whether the master sends device's read address or write address at the beginning of the data transfer sequence. In either case, the receiver must send an acknowledge bit to the transmitter to complete transmission of one data byte without any errors. When the device is written to, it acknowledges its write address as well as the following data bytes. When it is read from, device only acknowledges its read address.

The device generates an acknowledge bit, right after receiving eight bits of data, by pulling SDA Low during the INTB clock pulse's entire High period. The master generates a similar acknowledge byte when it reads from device. The transmitter must let go of SDA during the ninth clock cycle's high period, to allow the receiver to generate an acknowledge bit. The generation of the acknowledge bit is shown in [Figure 15](#).

When SDA remains High during this 9th clock pulse, this is defined as the Not Acknowledge signal. The master can then generate either a STOP condition to abort the transfer, or a repeated START condition to start a new transfer. There are five conditions that lead to the generation of a NACK:

1. No receiver is present on the bus with the transmitted address, so there is no device to respond with an acknowledge.
2. The receiver is unable to receive or transmit, because it is performing some real-time function and is not ready to start communication with the master.
3. During the transfer the receiver gets data or commands it does not understand.
4. During the transfer, the receiver cannot receive any more data bytes.
5. A master-receiver needs to signal the end of the transfer to the slave transmitter.

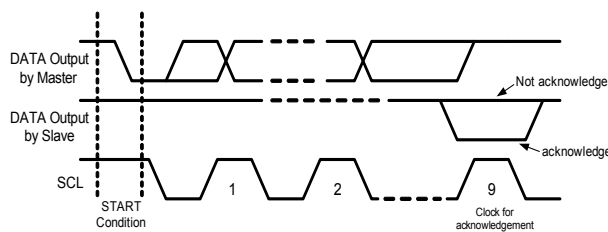

Figure 15. BUS acknowledge cycle

5.5.2 Writing to control registers

To write to device control registers, the master needs to initiate a communication link by first generating a START condition on the I²C bus. The master then sends the Write address. If the address matches to device's Write address, the device sends an acknowledge bit to the master. Next, the master sends the control register address. If device receives a valid I²C control register address, it returns an acknowledge bit. Following this, the master sends a byte of data to be written. The device receives this byte of data and sends an acknowledge bit back to master. The internal control register is updated right after an acknowledge bit is sent to master. If all the control registers need to be updated at once, there is no need to repeat the device and register address. The register address is incremented in the I²C block right after the acknowledge bit. Therefore, all the control registers' byte data can be updated serially at once. The write data format in single packet is shown in Figure 16 and Figure 17.

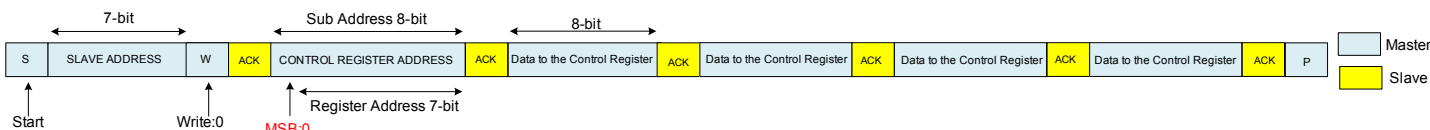

Figure 16. Repeated data write to a single register

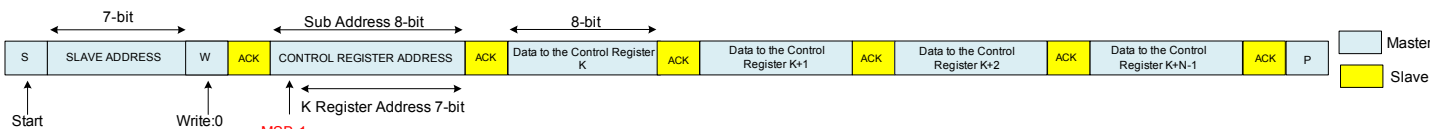

Figure 17. Burst data write to multiple registers

Note: A single byte read is initiated by the master with P immediately following the first data byte.

5.5.3 Reading to control registers

To read from device registers, the master has to generate a START condition. The master then must supply the device Write address. If this address matches the device Write address, an acknowledge bit is sent to master. Following this, the master sends the register address from which the master wants to read data. If the register address is valid, an acknowledge bit is returned to master. The master then sends a repeated START condition followed by device Read address. The device sends an acknowledge bit if the Read address is valid. Next, the device I²C sends a byte of data from the previously received register address. If the master acknowledges, then the register address in the device is incremented by one and the data from this register is sent to master again. Therefore, multiple registers can be read without sending repeated device and register addresses to device. If the master does not acknowledge or sends a STOP condition, the Read cycle is terminated. The device supports combined mode and split mode as shown in Figures 18 to 21.

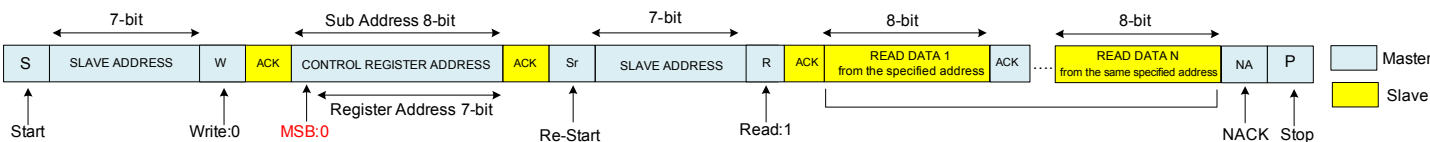

Figure 18. Repeated data read from a single register- combined mode

Note: A single byte read is initiated by the master with P immediately following first data byte.

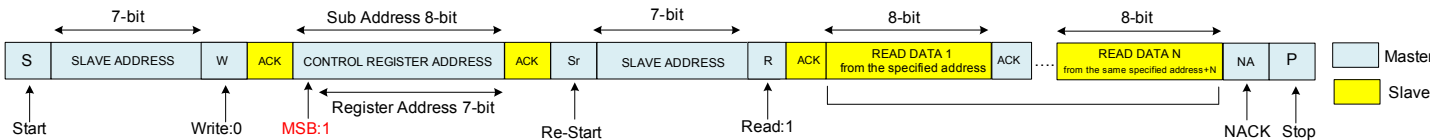

Figure 19. Burst data read from multiple registers- combined mode

Note: A single byte read is initiated by the master with P immediately following first data byte.

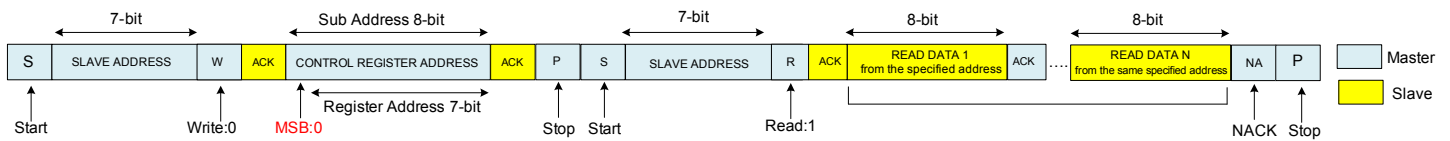

Figure 20. Repeated data read from a single register- split mode

Note: A single byte read is initiated by the master with P immediately following first data byte.

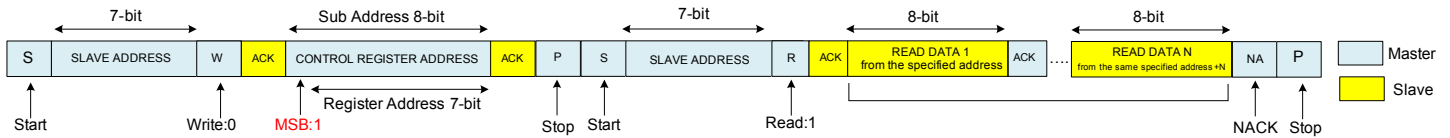

Figure 21. Burst data read from multiple registers- split mode

Note: A single byte read is initiated by Master with P immediately following first data byte.

5.5.4 I²C control registers

The BC3770 has one Full-speed I²C control for the application processor (AP).

Register Reset Condition: All registers in the I²C block are reset each time the VSYS falls below its falling UVLO threshold (typ. 2.5 V).

5.5.4.1 Slave address

The device supports 7-bit addressing only.

Bit 7, MSB	Bit 6	Bit 5	Bit 4	Bit 3	Bit 2	Bit 1	Bit 0, LSB
1	0	0	1	0	0	1	R/W

Slave address in binary	Slave address (write) in hex	Slave Address (Read) In hex
1001 001x	92	93

Acronyms

R: Read

R/C: Read and Clear

R/W: Read and Write

5.5.5 Control register map

Address (hex)	Register name	Reset (hex)	Bit 7	Bit 6	Bit 5	Bit 4	Bit 3	Bit 2	Bit 1	Bit 0
00	INT1	00	VBUSOVP	VBUSUVLO	VBUSINOK	AICL	VBUSLIMIT	BATOVLP	THEMSHDN	THEMREG
01	INT2	00	FASTTMROFF	NOBAT	WEAKBAT	OTGFAIL	PRETMROFF	CHGRSTF	DONE	TOPOFF
02	INT3	00	Reserved	Reserved	Reserved	Reserved	VSYSOK	VSYSNG	VSYSOLP	DISLIMIT
03	INTMSK1	03	VBUSOVPM	VBUSUVLOM	VBUSINOKM	AICLM	VBUSINLIMITM	BATOVPM	THEMSHDNM	THEMREGM
04	INTMSK2	B8	FASTTMROFFM	NOBATM	WEAKBATM	OTGFAILM	PRETMROFFM	CHGRSTFM	DONEM	TOPOFFM
05	INTMSK3	FF	Reserved	Reserved	Reserved	Reserved	VSYSOKM	VSYSNGM	VSYSOLPM	DISLIMITM
06	STATUS	N/A	Reserved	Reserved	Reserved	VSYSOLP	DISLIMIT	THEMSHDN	BATDET	SUSPEND
07	CTRL	42	Reserved	ENCOMPARTOR	Reserved	Reserved	RESET	SUSPEN	CHGEN	ENBOOST
08	VBUSCTRL	08	Reserved	Reserved	VBUSLIMIT					
09	CHGCTRL1	2F	Reserved	AICLTH			AUTOSTOP	AICLEN	PRECHG	
0A	CHGCTRL2	08	Reserved	Reserved	FASTCHG					
0B	CHGCTRL3	4C	BATREG				WEAKBAT			
0C	CHGCTRL4	05	Reserved	TOPOFF				DISLIMIT		
0D	CHGCTRL5	0F	Reserved	Reserved	VOTG		FASTTIMER		TOPOFFTIMER	

5.5.5.1 INT1: interrupt register 1 for abnormal conditions

Address (hex)	Mode		Reset condition:	Reset: 0x00
00	R/C		$VSYS \leq V_{SYS_UVLO}$	
Bit	Name	Reset	Description	
7	VBUSOVP	0	1: VBUS OVP event detected	
6	VBUSUVLO	0	1: VBUS falling UVLO detected	
5	VBUSINOK	0	1: Valid VBUS detected	
4	AICL	0	1: AICL threshold detected	
3	VBUSLIMIT	0	1: VBUS input current limit detected	
2	BATOVLP ^{(17), (18)}	0	1: BAT OVP detected	
1	THEMSHDN	0	1: Thermal shutdown detected	
0	THEMREG	0	1: Thermal regulation threshold detected	

Notes

17. These interrupts are to be set to 1 when "ENCOMPARTOR" bit 7 in the 07h register set to "1" AND no valid VBUS supply is at preset. If "ENCOMPARTOR" bit 7 is reset to "0" in no valid VBUS supply, these interrupt events are in no response.
18. These interrupts are to be forcibly overridden to alert the interrupt events in a valid VBUS attached.

5.5.5.2 INT2: interrupt register 2

Address (hex)	Mode		Reset condition: $V_{SYS} \leq V_{SYS_UVLO}$	Reset: 0x00
01	R/C			
Bit	Name	Reset	Description	
7	FASTTMROFF	0	1: Fast charger timer expired	
6	NOBAT	0	1: No battery threshold detected	
5	WEAKBAT ^{(19), (20)}	0	1: Weak battery threshold detected	
4	OTGFAIL	0	1: Boost failed detected due to overload	
3	PRETMROFF	0	1: Pre-charge timer expired	
2	CHGRSTF	0	1: Charger restart detected	
1	DONE	0	1: Top-off charge timer expired	
0	TOPOFF	0	1: Top-off threshold is detected	

Notes

19. These interrupts are to be set to 1 when “ENCOMPARTOR” bit 7 in the 07h register set to “1” AND no valid VBUS supply is at preset. If “ENCOMPARTOR” bit 7 is reset to “0” in no valid VBUS supply, these interrupt events are in no response.
20. These interrupts are to be forcibly overridden to alert the interrupt events in a valid VBUS attached.

5.5.5.3 INT3: interrupt register 3

Address (hex)	Mode		Reset condition: $V_{SYS} \leq V_{SYS_UVLO}$	Reset: 0x00
02	R/C			
Bit	Name	Reset	Description	
7:4	Reserved	0000	Write “0000”	
3	VSYSOK ^{(21), (22)}	0	1: VSYS rising 3.6 V detected in a valid VBUS attached	
2	VSYSNG ^{(21), (22)}	0	1: VSYS falling 3.4 V detected in a valid VBUS attached	
1	VSYSOLP	0	1: VSYS overload condition debounced is detected ($V_{SYS} \leq 3.4$ V) in a valid VBUS attached	
0	DISLIMIT ⁽²¹⁾	0	1: Current limit threshold detected in discharge mode	

Notes

21. These interrupts are to be set to 1 when “ENCOMPARTOR” bit 7 in the 07h register set to “1” AND no valid VBUS supply is at preset. If “ENCOMPARTOR” bit 7 is reset to “0” in no valid VBUS supply, these interrupt events are in no response.
22. These interrupts are to be forcibly overridden to alert the interrupt events in a valid VBUS attached.

5.5.5.4 INTMSK1: interrupt mask register 1

Address (hex)	MODE		Reset condition: $V_{SYS} \leq V_{SYS_UVLO}$	Reset: 0x03
03	R/W			
Bit	Name	Reset	Description	
7	VBUSOVPM	0	0: Interrupt is enabled 1: VBUS OVP interrupt masked	
6	VBUSUVLOM	0	0: Interrupt is enabled 1: VBUS falling UVLO interrupt masked	
5	VBUSINOKM	0	0: Interrupt is enabled 1: Valid VBUS interrupt masked	
4	AICLM	0	0: Interrupt is enabled 1: AICL interrupt masked	
3	VBUSINLIMITM	0	0: Interrupt is enabled 1: VBUS Input Current Limit interrupt masked	
2	BATOVPM	0	0: Interrupt is enabled 1: BAT OVP interrupt masked	
1	THEMSHDNM	1	0: Interrupt is enabled 1: Thermal shutdown interrupt masked	
0	THEMREGM	1	0: Interrupt is enabled 1: Thermal regulation interrupt masked	

5.5.5.5 INTMSK2: interrupt mask register 2

Address (hex)	Mode		Reset condition: $V_{SYS} \leq V_{SYS_UVLO}$	Reset: 0xB8
04	R/W			
Bit	Name	Reset	Description	
7	FASTTMROFFM	1	0: Interrupt is enabled 1: Fast charger timer expired interrupt masked	
6	NOBATM	0	0: Interrupt is enabled 1: No Battery interrupt masked	
5	WEAKBATM	1	0: Interrupt is enabled 1: Weak battery interrupt masked	
4	OTGFAILM	1	0: Interrupt is enabled 1: Boost failed interrupt masked	
3	PRETMROFFM	1	0: Interrupt is enabled 1: Pre-charge timer expired interrupt masked	
2	CHGRSTFM	0	0: Interrupt is enabled 1: Charger restart interrupt masked	
1	DONEM	0	0: Interrupt is enabled 1: Done interrupt masked	
0	TOPOFFM	0	0: Interrupt is enabled 1: Top-Off threshold interrupt masked	

5.5.5.6 INTMSK3: interrupt mask register 3

Address (hex)	Mode		Reset condition: $V_{SYS} \leq V_{SYS_UVLO}$	Reset: 0xFF
05	R/W			
Bit	Name	Reset	Description	
7:4	Reserved	1111	Write "1111"	
3	VSYSOKM	1	0: Interrupt is enabled 1: VSYS rising 3.6 V detection masked	
2	VSYSNGM	1	0: Interrupt is enabled 1: VSYS falling 3.4 V detection masked	
1	VSYSOLPM	1	0: Interrupt is enabled 1: VSYS overload condition detection masked	
0	DISLIMITM	1	0: Interrupt is enabled 1: Current limit threshold detection masked	

5.5.5.7 STATUS – status register

Address (hex)	Mode		Reset condition: $V_{SYS} \leq V_{SYS_UVLO}$	Reset: N/A
06	R			
Bit	Name	Reset	Description	
7:5	Reserved		Reserved for future use	
4	VSYSOLP		0: VSYS output is healthy ($3.6\text{ V} \leq V_{SYS} \leq V_{BAT_REG}$) 1: VSYS overloaded with a valid VBUS ($V_{SYS} \leq 3.4\text{ V}$)	
3	DISLIMIT		0: Current limit threshold not detected in discharge mode 1: Current limit threshold detected in discharge mode	
2	THEMSHDN		0: The die temperature is less than 130 °C. 1: The die temperature is between 150 °C and 130 °C	
1	BATDET		0: Battery detached (No Battery) 1: Battery attached (Battery at present)	
0	SUSPEND		0: Suspend mode is disabled 1: Suspend mode is enabled	

5.5.5.8 CTRL: on/off control register

Address (hex)	Mode		Reset condition: $V_{SYS} \leq V_{SYS_UVLO}$	reset: 0x42
07	R/W			
Bit	Name	Reset	Description	
7	Reserved	0	Write "0"	
6	ENCOMPARATOR	1	Enable/Disable the comparators to detect "BATOVP", WEAKBAT", "VSYOK", "VSYNG" and "DISLIMIT" interrupt events in the registers from 00h to 02h. 0: Turn Off the comparators 1: Turn On the comparators	
5	Reserved	0	Do Not write "1"	
4	Reserved	0	Do Not write "1"	
3	RESET	0	Software Reset 0: No Reset 1: Reset all charge parameters on all registers (except interrupt, interrupt mask registers and status register) (return to 0 after writing 1)	
2	SUSPEN	0	Enable/Disable Suspend mode (Turn off the FET between VBUS and PMID) 0: Disable Suspend mode (Q1 FET ON) 1: Enable Suspend mode (Q1 FET in Hi-Z Mode)	
1	CHGEN	1	Enable/Disable Battery Charger 0: Disabled 1: Enabled	
0	ENBOOST	0	Enable/Disable OTG mode in Boost 0: Disable OTG mode 1: Enable OTG mode	

5.5.5.9 VBUSCTRL: VBUS input current limit

Address (hex)	Mode		Reset condition: $V_{SYS} \leq V_{SYS_UVLO}$	Reset: 0x08
08	R/W			
Bit	Name	Reset	Description	
7:6	Reserved	00	Write "00"	
5:0	VBUSLIMIT	00 1000	Program the Input Current Limit, I_{IN_LIM} , on VBUS in mA Max current is limited to 2050 mA (All above 10 0111 set to 2.05 A) 500 mA Default $I_{IN_LIM} = [100 \text{ mA} + \text{Dec. (bit 5:0)} * 50 \text{ mA}] \text{ (mA)}$ i.g: 500 mA = 100 mA + Dec. 8 (Bin 00 1000) * 50 mA	

5.5.5.10 CHGCTRL1: charger control register 1

Address (hex)	Mode		Reset condition: $V_{SYS} \leq V_{SYS_UVLO}$	Reset: 0x2F
09	R/W			
Bit	Name	Reset	Description	
7	Reserved	0	Write "0"	
6:4	AICLTH	010	Program the AICL Threshold on VBUS 0x0: 4.3 V 0x1: 4.4 V 0x2: 4.5 V 0x3: 4.6 V 0x4: 4.7 V 0x5: 4.8 V 0x6: 4.9 V 0x7: 4.9 V	
3	AUTOSTOP	1	Charger AUTOSTOP Control 0: Charger is on continuously and stays in CV mode after top-off timer is expired. 1: Automatic stop is enabled. After top-off timer is expired, the charger turns off and goes into DONE state.	
2	AICLEN	1	Enable/Disable the function of Adaptive-Input Current Limit on VBUS 0: Disable 1: Enable	
1:0	PRECHG	11	Program the Pre-charge current in Pre-charge mode 00: 150 mA 01: 250 mA 10: 350 mA 11: 450 mA	

5.5.5.11 CHGCTRL2: charger control register 2

Address (hex)	mOde		Reset Condition: $V_{SYS} \leq V_{SYS_UVLO}$	Reset: 0x08
0A	R/W			
Bit	Name	Reset	Description	
7:6	Reserved	00	Write "00"	
5:0	FASTCHG	00 1000	Program the fast-charge current I_{FAST_CHG} , in mA Max current is limited to 2.0 A (all bits above 10 0110 set to 2.0 A) 500 mA Default $I_{FAST_CHG} = [100 \text{ mA} + \text{Dec. (bit 5:0)} * 50 \text{ mA}] \text{ (mA)}$ i.g: 500 mA = 100 mA + Dec. 8 (Bin 001000) * 50 mA	

5.5.5.12 CHGCTRL3: charger control register 3

Address (hex)	Mode		Reset condition: $V_{SYS} \leq V_{SYS_UVLO}$	Reset: 0x4C
0B	R/W			
Bit	Name	Reset	Description	
7:4	BATREG	0100	Program the battery regulation voltage on BATREG in 25 mV steps 0x0: 4.100 V 0x1: 4.125 V 0x2: 4.150 V 0x3: 4.175 V 0x4: 4.200 V 0x5: 4.225 V 0x6: 4.250 V 0x7: 4.275 V 0x8: 4.300 V 0x9: 4.325 V 0xA: 4.350 V 0xB: 4.375 V 0xC: 4.400 V 0xD: 4.425 V 0xE: 4.450 V 0xF: 4.475 V	
3:0	WEAKBAT	1100	Program the weak battery voltage threshold in 50 mV steps 0x0: 3.00 V 0x1: 3.05V 0x2: 3.10 V 0x3: 3.15 V 0x4: 3.20 V 0x5: 3.25 V 0x6: 3.30 V 0x7: 3.35 V 0x8: 3.40 V 0x9: 3.45 V 0xA: 3.50 V 0xB: 3.55 V 0xC: 3.60 V 0xD: 3.65 V 0xE: 3.70 V 0xF: 3.75 V	

5.5.5.13 CHGCTRL4: charger control register 4

Address (hex)	Mode		Reset condition: $V_{SYS} \leq V_{SYS_UVLO}$	Reset: 0x05
0C	R/W			
Bit	Name	Reset	Description	
7	Reserved	0		
6:3	TOPOFF	0000	Program the top-off charge current in 50 mA steps 0x0: 100 mA 0x1: 150 mA 0x2: 200 mA 0x3: 250 mA 0x4: 300 mA 0x5: 350 mA 0x6: 400 mA 0x7: 450 mA 0x8: 500 mA 0x9: 550 mA 0xA: 600 mA 0xB: 650 mA 0xC: 650 mA 0xD: 650 mA 0xE: 650 mA 0xF: 650 mA	
2:0	DISLIMIT	101	Program the discharge current limit in discharge mode 0x0: disabled 0x1: 2.0 A 0x2: 2.5 A 0x3: 3.0 A 0x4: 3.5 A 0x5: 4.0 A 0x6: 4.5 A 0x7: 5.0 A	

5.5.5.14 CHGCTRL5: charger control register 5

Address (hex)	Mode		Reset Condition: $V_{SYS} \leq V_{SYS_UVLO}$	Reset: 0x0F
0D	R/W			
Bit	Name	Reset	Description	
7:6	Reserved	00	Write "00"	
5:4	VOTG	00	Program the OTG voltage in boost mode on PMID 00: 5.0 V 01: 5.1 V 10: 5.2 V 11: 5.2 V	
3:2	FASTTIMER	11	Program the timer for Fast-charge current 00: 3.5 hours 01: 4.5 hours 10: 5.5 hours 11: Disabled	
1:0	TOPOFFTIMER	11	Program the timer for Top-Off in AUTOSTOP=1 00: 10 min 01: 20 min 10: 30 min 11: 45 min	

6 Typical applications

6.1 Introduction

The BC3770 can be configured in several applications. [Figure 22](#) shows the BC3770 in a typical application.

6.1.1 Application diagram

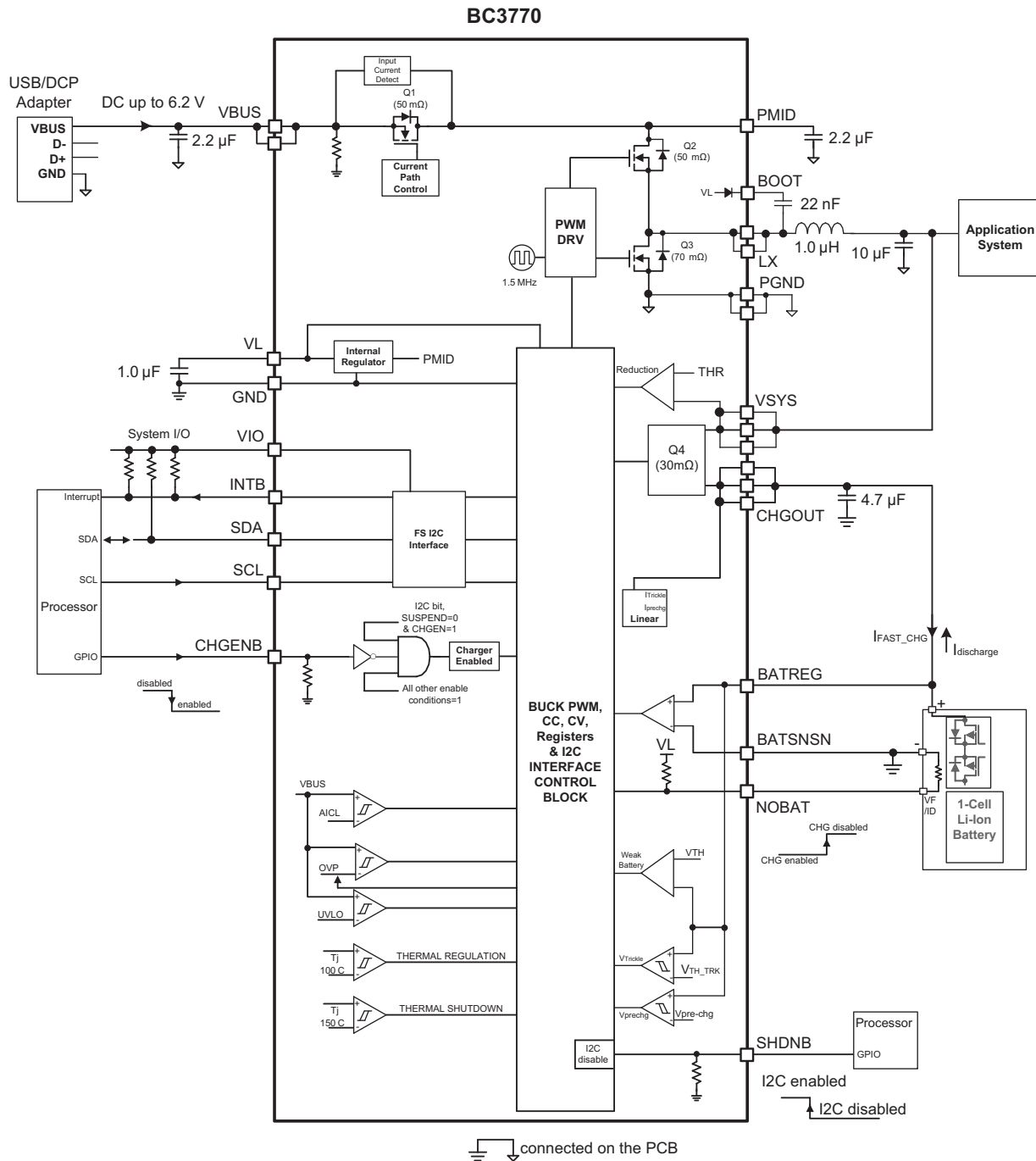

Figure 22. Typical applications

6.1.2 Application instructions

6.1.2.1 Determine the inductor, L

Selecting the proper inductor value is a critical design step for a DC-DC converter.

$$L = (V_{BUS_MAX} - V_{SYS_MIN}) \times \frac{V_{SYS_MIN}}{V_{BUS_MAX}} \times \frac{1}{f_{SW}} \times \frac{1}{LIR \times I_{OUTMAX}}$$

Where f_{SW} is the switching frequency and LIR is the inductor current ratio expressed as a percentage of I_{OUT} (e.g., for a 300 mA ripple current with a 1.0 A output current, LIR = 0.3 A/1.0 A = 0.3).

Depending on the desired load transient performance, LIR can be set between 0.2 and 0.5. An LIR value of 0.3 is a good trade-off between efficiency and load transient response. Increasing the LIR value results in more inductor ripple current, and speeds up the transient load response. Decreasing the LIR value results in lower inductor ripple current and slows down the transient load response. The peak current through the inductor should be considered when selecting the inductor. In particular, choose an inductor saturation current rating large enough to handle the expected current. Allowing the inductor core to saturate reduces the overall converter efficiency, and raises the temperature of both the inductor and the switching MOSFETs.

The inductor's peak operating current is calculated as follows:

$$I_{PEAK} = I_{OUTMAX} + \frac{(\Delta I)_{inductor}}{2}, \text{ where}$$

$$(\Delta I)_{inductor} = LIR \times I_{OUTMAX}$$

For instance, $V_{BUS} = 5.0 \text{ V}$, $V_{SYS} = 4.0 \text{ V}$, $I_{OUT} = 2.0 \text{ A}$, $f_{SW} = 1.5 \text{ MHz}$

$L = (5.0 \text{ V} - 3.6 \text{ V}) \times (3.6 \text{ V}/5.0 \text{ V}) \times (1/1.5 \text{ MHz}) \times (1/(0.3 \times 2 \text{ A})) = 1.12 \text{ } \mu\text{H}$.

Select the inductor to a standard 1.0 μH .

Then calculate the total ripple current with a 1.0 μH inductor:

$$(\Delta I)_{inductor} = LIR \times I_{OUTMAX} = 0.3 \times 2.0 \text{ A} = 0.6 \text{ A}$$

The peak current on the inductor is 2.3 A.

Therefore, select an inductor that has a higher rated current than the peak current and 1.0 μH .

Another consideration is the inductor DC resistance, since it directly affects the efficiency of the converter. Ideally, the inductor with the lower DC resistance should be considered to achieve higher efficiency.

Table 5. Recommended inductors

Part Number	Inductance (μH)	Size	DCR ($\text{m}\Omega$)	Rated Current (mA) $\Delta T = 40 \text{ }^\circ\text{C}$	Application	Vendor
CIGT2016201610GM1R0MNE	1.0	2.05 x 1.65 x 0.9 mm	67	2300	2A charge	SEMCO
CIG22E1R0MNE	1.0	2.5 x 2.0 x 1.0 mm	48	2300	2A charge	SEMCO
LQH32PN1R0-NN0	1.0	3.2 x 2.5 x 1.55 mm	54	2300	2A charge	Murata
1269AS-H-1R0M=P2	1.0	2.5 x 2 x 1.0 mm	60	3000	2A charge	TOKO
IFSC1008ABER1R0M01	1.0	2.5 x 2.0 x 1.2 mm	43	2600	2A charge	Vishay
CIG2MW1R0MNE	1.0	2.0 x 1.6 mm	85	1400	1A Charge	SEMCO
1285AS-H-1R0N=P2	1.0	2 x 1.6 x 1.0 mm	80	2300	1A Charge	TOKO

6.1.2.2 Output capacitors characteristics

The ceramic capacitors with X5R or X7R rated, low ESR are recommended to absorb all reflected switching ripple current generated during charging or system powering. The output capacitors need to ensure stability of the buck converter. Special attention should be paid when selecting these components. As shown Figure 23 (Source: Murata web site), the DC bias of these capacitors can result in a capacitance value that falls below the minimum value given in the recommended capacitance.

The ceramic capacitor's capacitance can vary with temperature and thickness. The capacitor type X7R, that operates over a temperature range of -55 °C to +125 °C. The capacitor type X5R has a similar tolerance over a reduced temperature range of -55 °C to +85 °C. Tantalum capacitors are not recommended due to a higher ESR values.

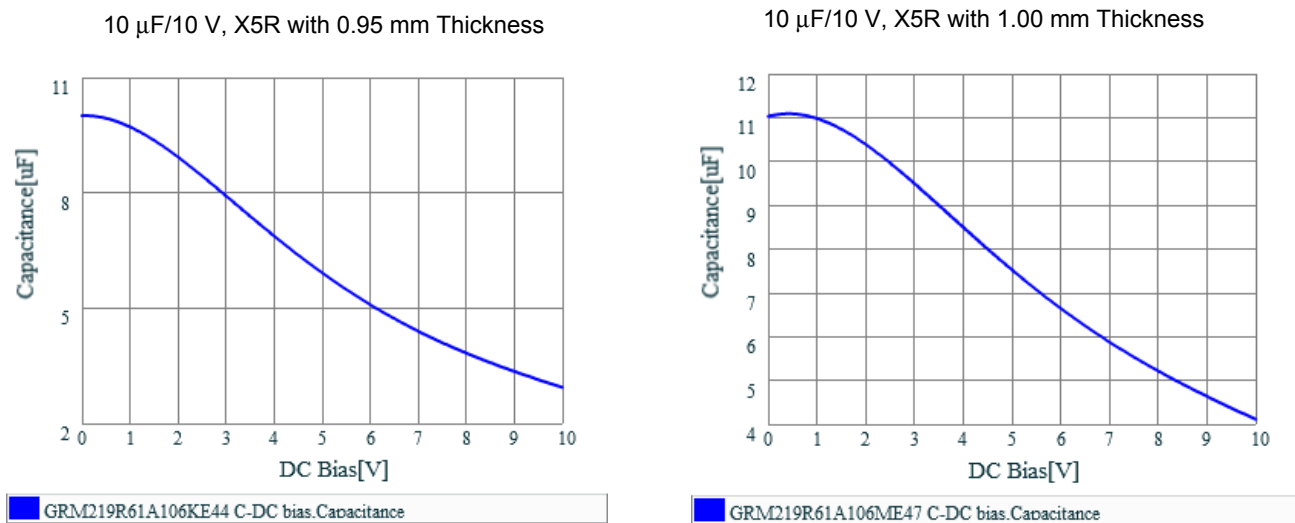

Figure 23. Capacitor DC bias

6.1.2.3 Output capacitor selection

The output capacitor of a switching converter absorbs the AC ripple current from the inductor and provides the initial response to a load transient. The ripple voltage at the output of the converter is the product of the ripple current flowing through the output capacitor and the impedance of the capacitor. The impedance of the capacitor can be dominated by capacitive, resistive, or inductive elements within the capacitor, depending on the frequency of the ripple current. Ceramic capacitors have a very low ESR and remain capacitive up to high frequencies. Their inductive component can usually be neglected at the frequency ranges where the switcher operates. For a desired voltage ripple at the output, the output capacitance should be decided by the following formula:

$$V_{\text{OUT-ripple-pp}} = \frac{(\Delta I)_{\text{ripple}}}{8 \times f \times C_{\text{OUT}}}$$

$$\text{where } (\Delta I)_{\text{ripple}} = \frac{D \times (V_{\text{IN}} - V_{\text{OUT}})}{2 \times L \times f} \quad \text{and} \quad D = \text{Duty} = \frac{V_{\text{OUT}}}{V_{\text{IN}}}$$

6.1.2.4 Input and output capacitors

The input capacitors with a 2.2 µF, X5R or X7R rated, low ESR are recommended to absorb all reflected switching ripple current generated during charging or system powering. The output capacitors need to ensure stability of the charger and buck converter. A 10 µF on VSYS and a 4.7 µF on CHGOUT with X5R or X7R rated with an appropriate thickness, low ESR is able to make stable operations.

6.1.2.5 PMID output capacitor

The capacitor for PMID is used to accurately sense input current levels for VBUS input. It is recommended to use a 2.2 µF ceramic capacitor, X5R or X7R rated, low ESR. The voltage rating for a capacitor depends on the maximum input voltage protection rating.

6.1.2.6 PCB layout considerations

The device contains a high-frequency switching converter. Therefore, the PCB layout is a very important design practice to ensure a satisfactory performance. The following provides some guidelines.

1. The power loop is composed of the inductor, the input and output capacitor, the LX pin and the PGND pin. It is important to make the power loop as small as possible and the connecting traces among them should be direct, short and wide. They should be placed as close as possible to their respective the IC pins.
2. The switching node of the converter, the LX pin, and the traces connected to this node are very noisy. This trace keeps other noise sensitive traces separated.
3. The GND and PGND should connect to the power ground plane at only one point, to minimize the effects of power ground currents. Also, battery ground should connect directly to the power ground plane.
4. Connect the BATREG pin directly to the + terminal on the battery cell and connect the BATSNSN pin directly to the – terminal on the battery cell, to regulate the V_{BAT_REG} battery regulation voltage as close to the target as possible.
5. One bypass capacitor for PMID should be placed as close to the pin and power ground as possible.

Figure 24 is an example layout for some key components.

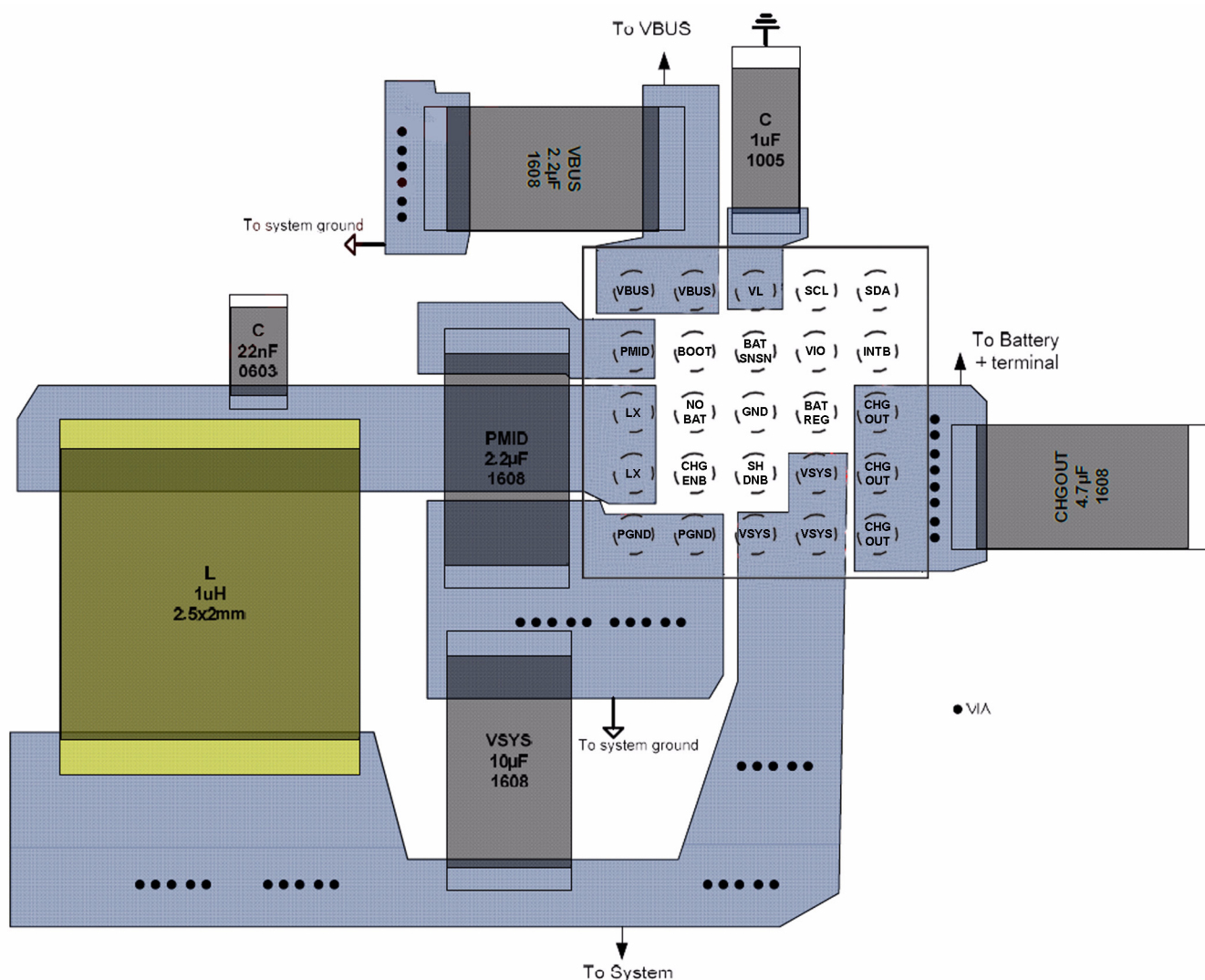

Figure 24. Key component layout example

6.1.2.7 Bill of materials

Figure 22 shows a typical connection diagram with an application processor on the mobile system. The following table lists the external components for this diagram.

Table 6. Bill of materials (23)

Item	Qty.	Schematic label	Value	Description (L x W in mm)	Part number	Assy. Opt.
1	1	VBUS	2.2 μ F	1.0 x 0.5 or 1.6 x 0.8, 10 V or higher, X5R, ceramic capacitor		
2	1	PMID	2.2 μ F	1.6 x 0.8 x 1.0, 10 V or higher, X5R, ceramic capacitor		
3	1	VL	1.0 μ F	1.0 x 0.5, 10 V or higher, X5R, ceramic capacitor		
4	1	CHGOUT	4.7 μ F	1.6 x 0.8, 10 V or higher, X5R, ceramic capacitor		
5	1	VSYS	10 μ F	1.6 x 0.8, 10 V or higher, X5R, ceramic capacitor		
6	1	LX	1.0 μ H	2.05 x 1.65, CIGT inductor in the recommended table recommended		
7	1	BOOT	22 nF	1.0 x 0.5, 10 V, X5R, ceramic capacitor		
8	1	NOBAT	100 k Ω	0.6 x 0.3, a pull-down resistor to connect to 1.8 V VDD ADC Input		
9	1	INTB	200 k Ω	0.6 x 0.3, a Pull-up resistor to system I/O voltage rail, VIO		
10	1	SDA	2.2 k Ω or 1.5 k Ω	1.0 x 0.5, a Pull-Up resistor to system I/O voltage rail, VIO		
11	1	SCL	2.2 k Ω or 1.5 k Ω	1.0 x 0.5, a Pull-Up resistor to system I/O voltage rail, VIO		

Notes

23. NXP does not assume liability, endorse, or warrant components from external manufacturers are referenced in circuit drawings or tables. While NXP offers component recommendations in this configuration, it is the customer's responsibility to validate their application.
24. Do not populate
25. **Critical components.** For critical components, it is vital to use the manufacturer listed.

7 Packaging

7.1 Package mechanical dimensions

Package dimensions are provided in package drawings. To find the most current package outline drawing, go to www.nxp.com and perform a keyword search for the drawing's document number.

Table 7.

Package	Suffix	Package outline drawing number
25-Pin WLCSP	CS	98ASA00848D

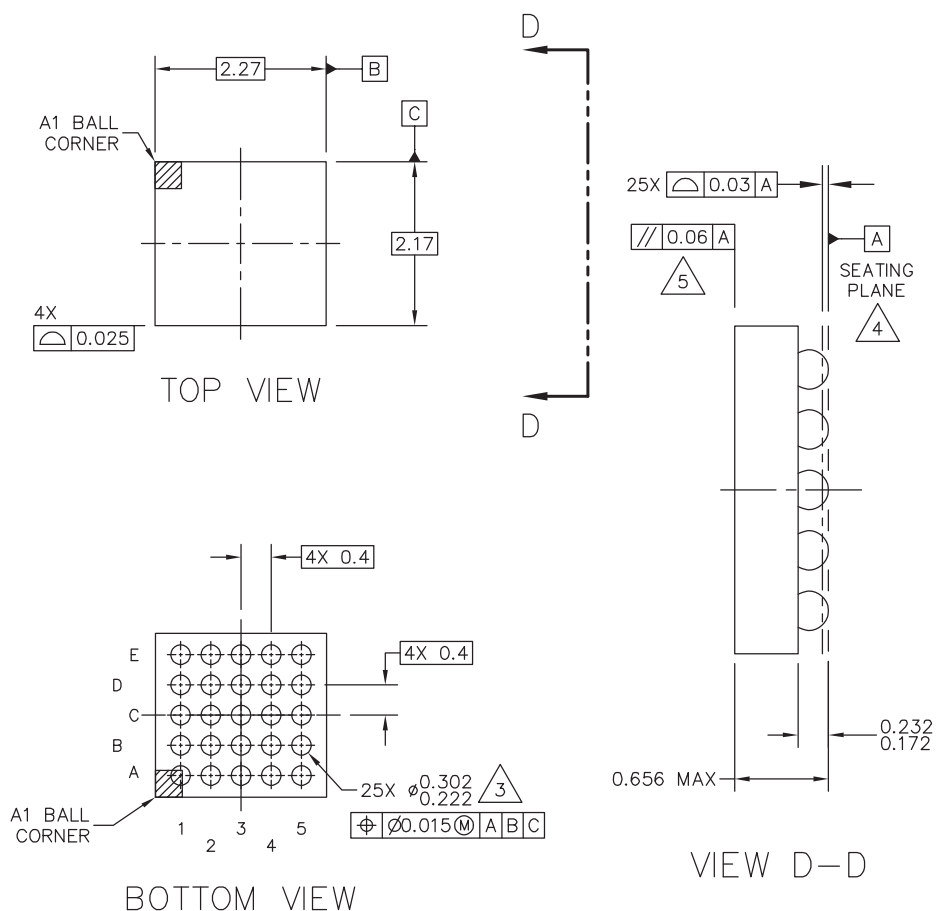

© NXP SEMICONDUCTORS N.V. ALL RIGHTS RESERVED	MECHANICAL OUTLINE	PRINT VERSION NOT TO SCALE
TITLE: WLCSP, 2.27 X 2.17 X 0.622 PKG, 0.4 MM PITCH, 25 I/O	DOCUMENT NO: 98ASA00848D	REV: A
	STANDARD: NON-JEDEC	
	SOT1401-2	14 JAN 2016

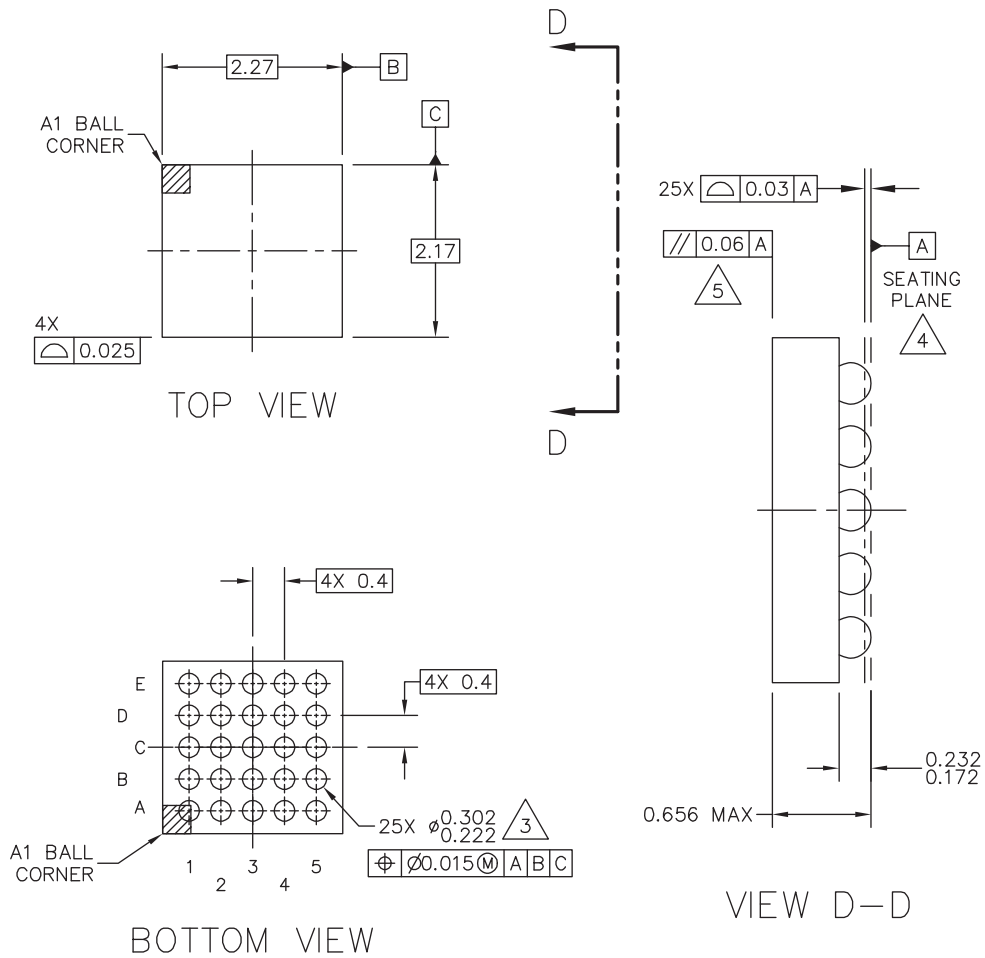

© NXP SEMICONDUCTORS N.V. ALL RIGHTS RESERVED	MECHANICAL OUTLINE	PRINT VERSION NOT TO SCALE
TITLE: WLCSP, 2.27 X 2.17 X 0.622 PKG, 0.4 MM PITCH, 25 I/O	DOCUMENT NO: 98ASA00848D	REV: A
	STANDARD: NON-JEDEC	
	SOT1401-2	14 JAN 2016

8 Revision history

Revision	Date	Description of Changes
1.0	12/2014	<ul style="list-style-type: none">Initial release
	2/2015	<ul style="list-style-type: none">Corrected Figure 1Updated Applications on page 1Corrected typo in Table 2, BC3770 pin definitions
	10/2015	<ul style="list-style-type: none">Corrected part number in Table 1, Orderable part variations
	7/2016	<ul style="list-style-type: none">Updated to NXP document form and style



How to Reach Us:

Home Page:

[NXP.com](http://www.nxp.com)

Web Support:

<http://www.nxp.com/support>

Information in this document is provided solely to enable system and software implementers to use NXP products.

There are no expressed or implied copyright licenses granted hereunder to design or fabricate any integrated circuits based on the information in this document. NXP reserves the right to make changes without further notice to any products herein.

NXP makes no warranty, representation, or guarantee regarding the suitability of its products for any particular purpose, nor does NXP assume any liability arising out of the application or use of any product or circuit, and specifically disclaims any and all liability, including without limitation, consequential or incidental damages. "Typical" parameters that may be provided in NXP data sheets and/or specifications can and do vary in different applications, and actual performance may vary over time. All operating parameters, including "typicals," must be validated for each customer application by the customer's technical experts. NXP does not convey any license under its patent rights nor the rights of others. NXP sells products pursuant to standard terms and conditions of sale, which can be found at the following address:

<http://www.nxp.com/terms-of-use.html>.

NXP, the NXP logo, Freescale, the Freescale logo and SMARTMOS are trademarks of NXP B.V. All other product or service names are the property of their respective owners. All rights reserved.

© 2016 NXP B.V.

Document Number: MC32BC3770

Rev. 1.0

7/2016





Компания «ЭлектроПласт» предлагает заключение долгосрочных отношений при поставках импортных электронных компонентов на взаимовыгодных условиях!

Наши преимущества:

- Оперативные поставки широкого спектра электронных компонентов отечественного и импортного производства напрямую от производителей и с крупнейших мировых складов;
- Поставка более 17-ти миллионов наименований электронных компонентов;
- Поставка сложных, дефицитных, либо снятых с производства позиций;
- Оперативные сроки поставки под заказ (от 5 рабочих дней);
- Экспресс доставка в любую точку России;
- Техническая поддержка проекта, помощь в подборе аналогов, поставка прототипов;
- Система менеджмента качества сертифицирована по Международному стандарту ISO 9001;
- Лицензия ФСБ на осуществление работ с использованием сведений, составляющих государственную тайну;
- Поставка специализированных компонентов (Xilinx, Altera, Analog Devices, Intersil, Interpoint, Microsemi, Aeroflex, Peregrine, Syfer, Eurofarad, Texas Instrument, Miteq, Cobham, E2V, MA-COM, Hittite, Mini-Circuits, General Dynamics и др.);

Помимо этого, одним из направлений компании «ЭлектроПласт» является направление «Источники питания». Мы предлагаем Вам помощь Конструкторского отдела:

- Подбор оптимального решения, техническое обоснование при выборе компонента;
- Подбор аналогов;
- Консультации по применению компонента;
- Поставка образцов и прототипов;
- Техническая поддержка проекта;
- Защита от снятия компонента с производства.



Как с нами связаться

Телефон: 8 (812) 309 58 32 (многоканальный)

Факс: 8 (812) 320-02-42

Электронная почта: org@eplast1.ru

Адрес: 198099, г. Санкт-Петербург, ул. Калинина, дом 2, корпус 4, литера А.