

PART NUMBER
SEE TABLE

REVISIONS			
REV	DESCRIPTION	DATE	DWN
A	EC-12368 Updated TP spec for contact location	12/15/16	AP

- NOTES:
- MATERIAL
HOUSING: HIGH TEMPERATURE THERMOPLASTIC
CONTACT: COPPER ALLOY
CONTACT PLATING: UNDERPLATE WITH NICKEL,
HARD GOLD IN MATING AREA
PURE MATTE TIN ON CONTACT TAIL
 - Please refer to Product Specification for mechanical and electrical specification.
 - Datum B is defined as the plane intersecting the $\phi 0.70\text{mm}$ post and parallel to Datum D
 - Datum C is defined as the plane intersecting the $\phi 0.70\text{mm}$ post and perpendicular to Datum B.
 - This dimension is measured (for each Solder Lead) as the deviation from a best-fit plane created from the surfaces referenced at the ends of the part.
 - This dimension is measured (for each Solder Lead) as the deviation from a best-fit plane created from all the Solder Leads.

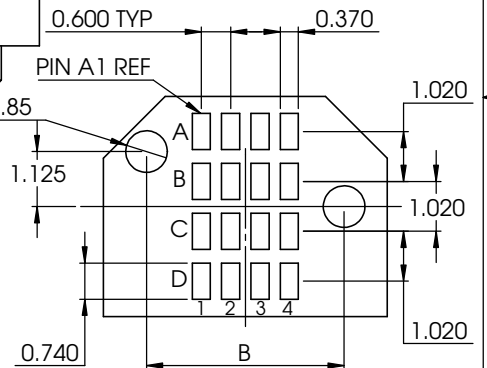
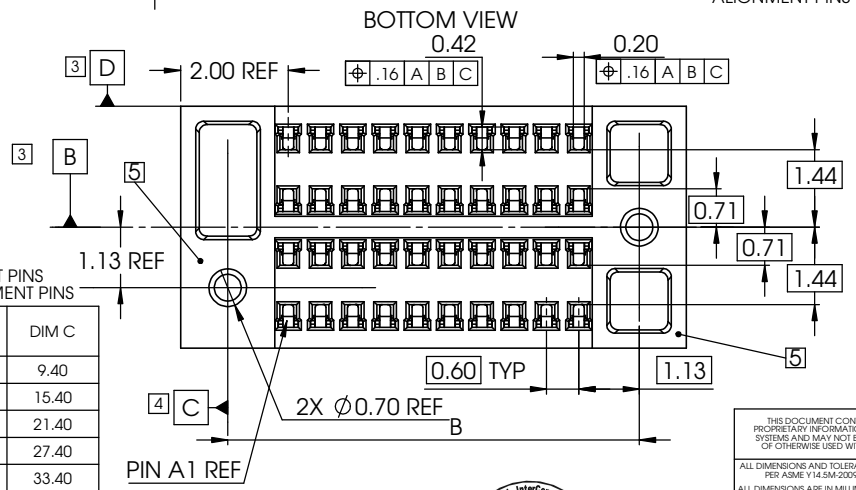
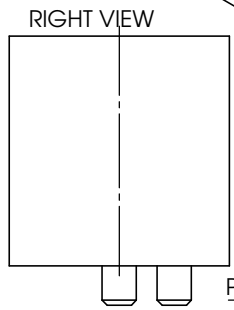
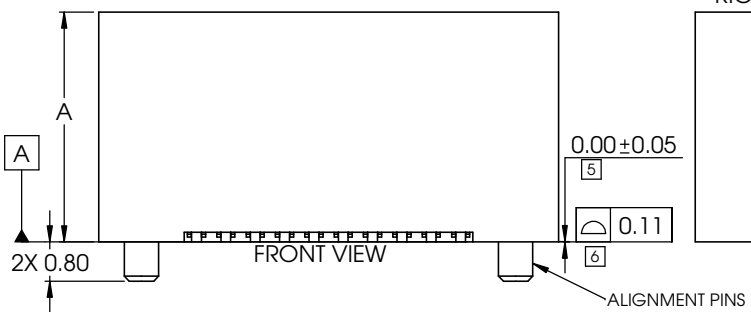
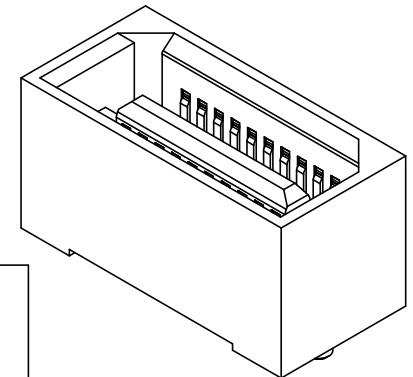
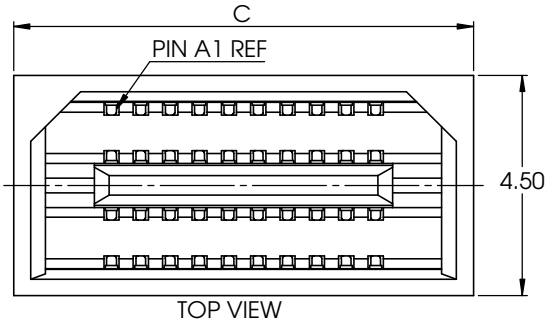

11826-XXX

MATED HEIGHT	DIM A	NO POS X4	DIM B	DIM C
A	04	10	7.65	9.40
B	05	20	13.65	15.40
C	06	30	19.65	21.40
D	07	40	25.65	27.40
E	08	50	31.65	33.40
F	09	60	37.65	39.40
G	10	70	43.65	45.40

A: WITH ALIGNMENT PINS
B: WITHOUT ALIGNMENT PINS

EXAMPLE SHOWN:
5mm STACK HEIGHT, 10 POS, WITH ALIGNMENT PINS = 11826 - BAA



METRIC

THIS DOCUMENT CONTAINS CONFIDENTIAL AND PROPRIETARY INFORMATION OF AMPHENOL INTERCON SYSTEMS AND MAY NOT BE DISCLOSED, REPRODUCED OR OTHERWISE USED WITHOUT WRITTEN PERMISSION

ALL DIMENSIONS AND TOLERANCES PER ASME Y14.5M-2009
ALL DIMENSIONS ARE IN MILLIMETERS UNLESS OTHERWISE SPECIFIED

THIRD ANGLE PROJECTION

INSPECTION
 ◇ FIRST PIECE
 △ SPC
 ○ IN-PROCESS

TOLERANCES UNLESS SPECIFIED OTHERWISE
 1PLC ±0.3
 2PLC ±0.13
 3PLC ±0.050
 ANGLES ±1°

Amphenol InterCon Systems AMPHENOL INTERCON SYSTEMS INC. Etters, PA 17319

NAME: LYNX PLUG ASSEMBLY

SIZE: B	PROD CODE: 445	DRAWING NUMBER: C- 11826	REV: A
MATERIAL: □	FINISH: □	SCALE: 10:1	CUSTOMER
		SHEET 1 OF 3	

PART NUMBER
SEE TABLE

REVISIONS			
REV	DESCRIPTION	DATE	DWN
A	SEE SHEET 1	12/15/16	AP

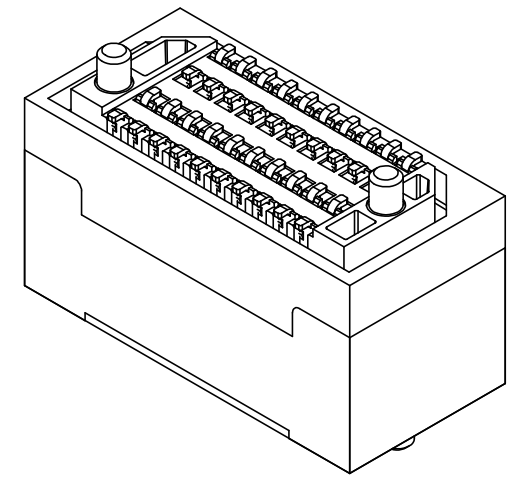
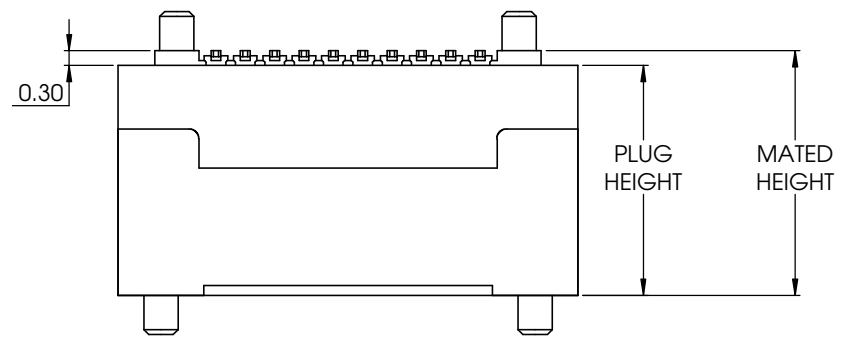

	MATED HEIGHT	PLUG HEIGHT
A	04	3.70
B	05	4.70
C	06	5.70
D	07	6.70
E	08	7.70
F	09	8.70
G	10	9.70

<small>THIS DOCUMENT CONTAINS CONFIDENTIAL AND PROPRIETARY INFORMATION OF AMPHENOL INTERCON SYSTEMS AND MAY NOT BE DISCLOSED, REPRODUCED OR OTHERWISE USED WITHOUT WRITTEN PERMISSION</small>				AMPHENOL INTERCON SYSTEMS INC. Eters, PA 17319	
<small>ALL DIMENSIONS AND TOLERANCES PER ASME Y14.5M-2009</small> <small>ALL DIMENSIONS ARE IN MILLIMETERS UNLESS OTHERWISE SPECIFIED</small>		THIRD ANGLE PROJECTION 		NAME LYNX PLUG ASSEMBLY	
INSPECTION ◇ FIRST PIECE △ SPC △ IN-PROCESS		TOLERANCES UNLESS SPECIFIED OTHERWISE 1PLC ±0.3 2PLC ±0.13 3PLC ±0.050 ANGLES ±1°		SIZE B	PROD CODE 445
MATERIAL 1		FINISH 2		DRAWING NUMBER C- 11826	REV A
METRIC		SCALE 10:1	CUSTOMER		SHEET 2 OF 3

TAPE AND REEL PACKAGING

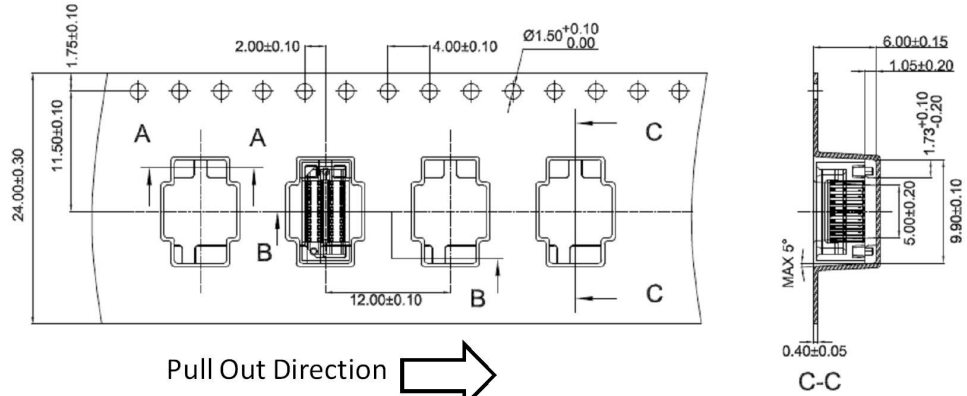

Pull Out Direction →

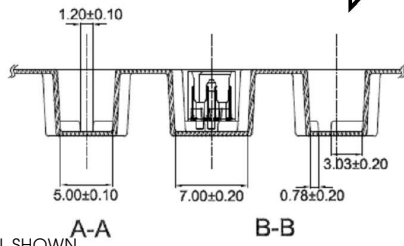

POS	TAPE WIDTH
10	24.00 +/- 0.30 MM
20	32.00 +/- 0.30 MM
30	32.00 +/- 0.30 MM
40	44.00 +/- 0.30 MM
50	56.00 +/- 0.30 MM
60	56.00 +/- 0.30 MM
70	56.00 +/- 0.30 MM

*5MM PLUG 10 POSITION TAPE AND REEL SHOWN

KAPTON TAPE

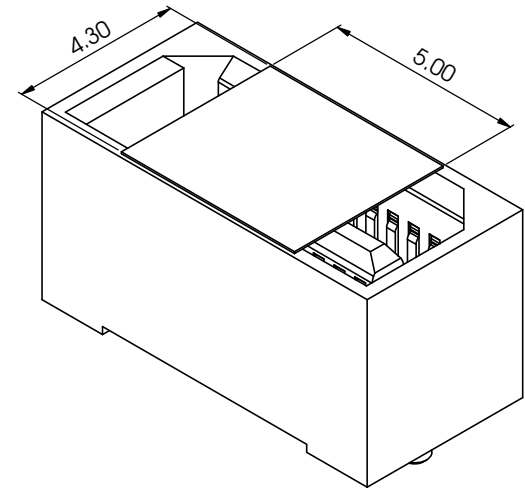

POS	LENGTH	WIDTH	THICKNESS
10	5 MM	4.3 MM	0.05 MM
20	5 MM	4.3 MM	0.05 MM
30	15 MM	4.3 MM	0.05 MM
40	15 MM	4.3 MM	0.05 MM
50	15 MM	4.3 MM	0.05 MM
60	15 MM	4.3 MM	0.05 MM
70	15 MM	4.3 MM	0.05 MM

THIS DOCUMENT CONTAINS CONFIDENTIAL AND PROPRIETARY INFORMATION OF AMPHENOL INTERCON SYSTEMS AND MAY NOT BE DISCLOSED, REPRODUCED OR OTHERWISE USED WITHOUT WRITTEN PERMISSION

Amphenol AMPHENOL INTERCON SYSTEMS INC.
InterCon Systems Efters, PA 17319

ALL DIMENSIONS AND TOLERANCES PER ASME Y14.5M-2009
 ALL DIMENSIONS ARE IN MILLIMETERS UNLESS OTHERWISE SPECIFIED

THIRD ANGLE PROJECTION

INSPECTION: FIRST PIECE (◇), SPC (△), IN-PROCESS (○)

TOLERANCES UNLESS SPECIFIED OTHERWISE:
 1PLC ±0.3
 2PLC ±0.13
 3PLC ±0.050
 ANGLES ±1°

NAME: **LYNX PLUG ASSEMBLY**

SIZE: **B** PROD CODE: 445 DRAWING NUMBER: C-11826 REV: A

MATERIAL: 1 FINISH: 2 SCALE: 10:1 CUSTOMER SHEET 3 OF 3

METRIC



Компания «ЭлектроПласт» предлагает заключение долгосрочных отношений при поставках импортных электронных компонентов на взаимовыгодных условиях!

Наши преимущества:

- Оперативные поставки широкого спектра электронных компонентов отечественного и импортного производства напрямую от производителей и с крупнейших мировых складов;
- Поставка более 17-ти миллионов наименований электронных компонентов;
- Поставка сложных, дефицитных, либо снятых с производства позиций;
- Оперативные сроки поставки под заказ (от 5 рабочих дней);
- Экспресс доставка в любую точку России;
- Техническая поддержка проекта, помощь в подборе аналогов, поставка прототипов;
- Система менеджмента качества сертифицирована по Международному стандарту ISO 9001;
- Лицензия ФСБ на осуществление работ с использованием сведений, составляющих государственную тайну;
- Поставка специализированных компонентов (Xilinx, Altera, Analog Devices, Intersil, Interpoint, Microsemi, Aeroflex, Peregrine, Syfer, Eurofarad, Texas Instrument, Miteq, Cobham, E2V, MA-COM, Hittite, Mini-Circuits, General Dynamics и др.);

Помимо этого, одним из направлений компании «ЭлектроПласт» является направление «Источники питания». Мы предлагаем Вам помощь Конструкторского отдела:

- Подбор оптимального решения, техническое обоснование при выборе компонента;
- Подбор аналогов;
- Консультации по применению компонента;
- Поставка образцов и прототипов;
- Техническая поддержка проекта;
- Защита от снятия компонента с производства.



Как с нами связаться

Телефон: 8 (812) 309 58 32 (многоканальный)

Факс: 8 (812) 320-02-42

Электронная почта: org@eplast1.ru

Адрес: 198099, г. Санкт-Петербург, ул. Калинина, дом 2, корпус 4, литера А.