

PART NUMBER
SEE TABLE

REVISIONS			
REV	DESCRIPTION	DATE	DWN
A	EC-12368 Updated TP spec for contact location	12/15/16	AP

- NOTES:
- MATERIAL  
HOUSING: HIGH TEMPERATURE THERMOPLASTIC  
CONTACT: COPPER ALLOY  
CONTACT PLATING: UNDERPLATE WITH NICKEL,  
HARD GOLD IN MATING AREA  
PURE MATTE TIN ON CONTACT TAIL
  - Please refer to Product Specification for mechanical and electrical specification.
  - Datum B is defined as the plane intersecting the  $\phi 0.70\text{mm}$  post and parallel to Datum D
  - Datum C is defined as the plane intersecting the  $\phi 0.70\text{mm}$  post and perpendicular to Datum B.
  - This dimension is measured (for each Solder Lead) as the deviation from a best-fit plane created from the surfaces referenced at the ends of the part.
  - This dimension is measured (for each Solder Lead) as the deviation from a best-fit plane created from all the Solder Leads.

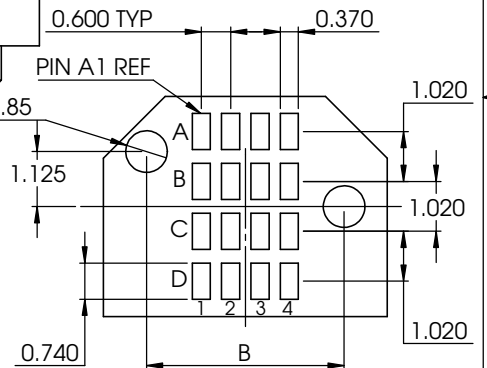
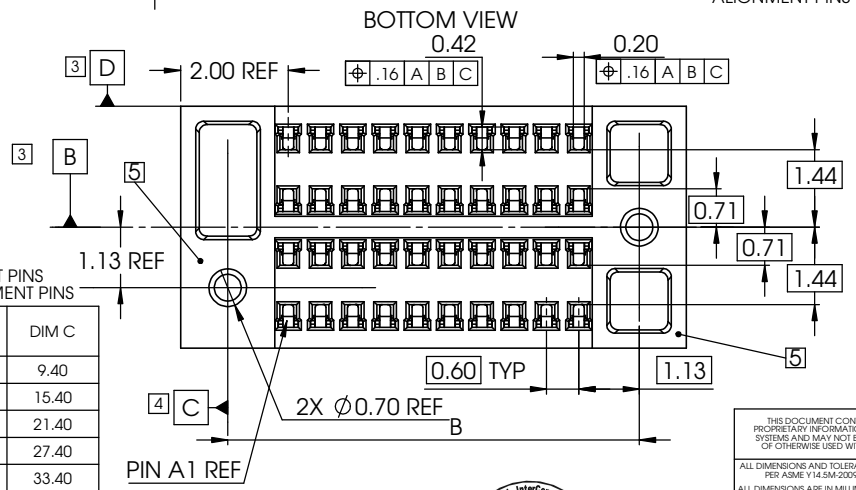
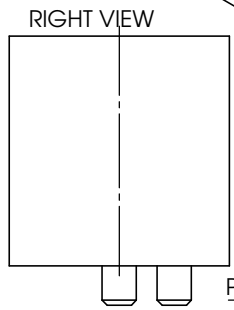
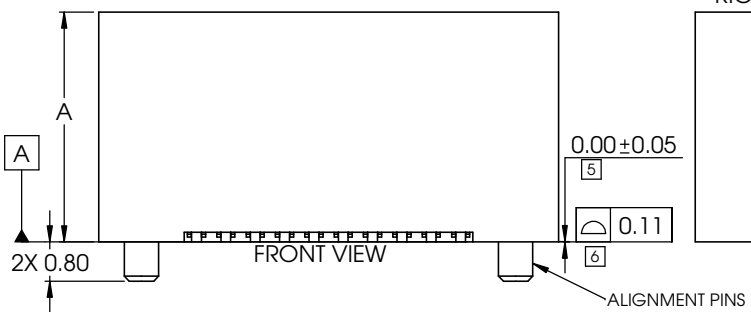
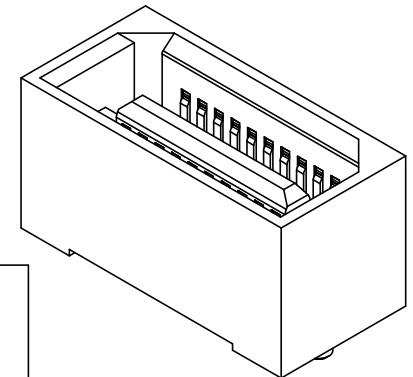
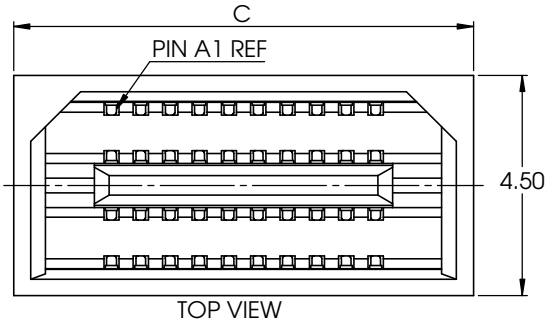

11826-XXX

MATED HEIGHT	DIM A	NO POS X4	DIM B	DIM C
A	04	3.70		
B	05	4.70		
C	06	5.70		
D	07	6.70		
E	08	7.70		
F	09	8.70		
G	10	9.70		

A: WITH ALIGNMENT PINS  
B: WITHOUT ALIGNMENT PINS

	NO POS X4	DIM B	DIM C
A	10	7.65	9.40
B	20	13.65	15.40
C	30	19.65	21.40
D	40	25.65	27.40
E	50	31.65	33.40
F	60	37.65	39.40
G	70	43.65	45.40

EXAMPLE SHOWN:  
5mm STACK HEIGHT, 10 POS, WITH ALIGNMENT PINS = 11826 - BAA



**METRIC**

THIS DOCUMENT CONTAINS CONFIDENTIAL AND PROPRIETARY INFORMATION OF AMPHENOL INTERCON SYSTEMS AND MAY NOT BE DISCLOSED, REPRODUCED OR OTHERWISE USED WITHOUT WRITTEN PERMISSION

ALL DIMENSIONS AND TOLERANCES PER ASME Y14.5M-2009  
ALL DIMENSIONS ARE IN MILLIMETERS UNLESS OTHERWISE SPECIFIED

THIRD ANGLE PROJECTION

INSPECTION  
 ◇ FIRST PIECE  
 △ SPC  
 ○ IN-PROCESS

TOLERANCES UNLESS SPECIFIED OTHERWISE  
 1PLC ±0.3  
 2PLC ±0.13  
 3PLC ±0.050  
 ANGLES ±1°

Amphenol InterCon Systems AMPHENOL INTERCON SYSTEMS INC. Etters, PA 17319

NAME: LYNX PLUG ASSEMBLY

SIZE: <b>B</b>	PROD CODE: 445	DRAWING NUMBER: C- 11826	REV: A
MATERIAL: □	FINISH: □	SCALE: 10:1	CUSTOMER
		SHEET 1 OF 3	

PART NUMBER  
SEE TABLE

REVISIONS			
REV	DESCRIPTION	DATE	DWN
A	SEE SHEET 1	12/15/16	AP

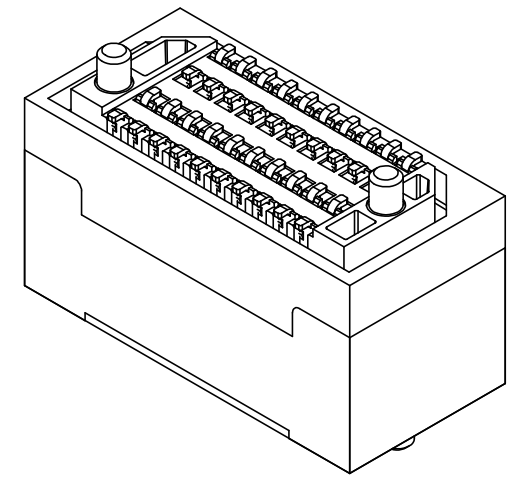
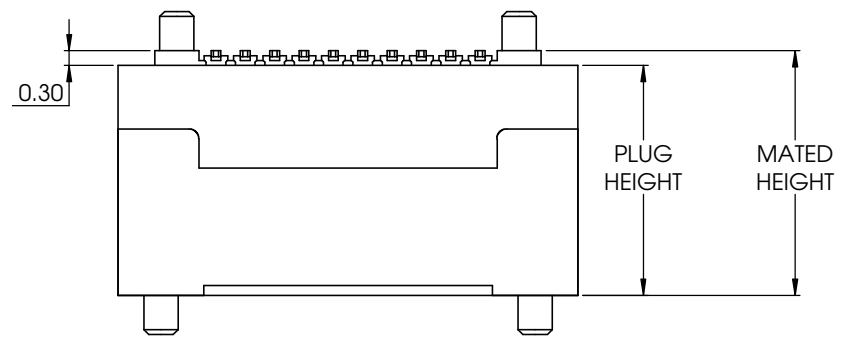

	MATED HEIGHT	PLUG HEIGHT
A	04	3.70
B	05	4.70
C	06	5.70
D	07	6.70
E	08	7.70
F	09	8.70
G	10	9.70

<small>THIS DOCUMENT CONTAINS CONFIDENTIAL AND PROPRIETARY INFORMATION OF AMPHENOL INTERCON SYSTEMS AND MAY NOT BE DISCLOSED, REPRODUCED OR OTHERWISE USED WITHOUT WRITTEN PERMISSION</small>				AMPHENOL INTERCON SYSTEMS INC. Eters, PA 17319	
<small>ALL DIMENSIONS AND TOLERANCES PER ASME Y14.5M-2009</small> <small>ALL DIMENSIONS ARE IN MILLIMETERS UNLESS OTHERWISE SPECIFIED</small>		THIRD ANGLE PROJECTION 		NAME <b>LYNX PLUG ASSEMBLY</b>	
INSPECTION ◇ FIRST PIECE △ SPC △ IN-PROCESS		TOLERANCES UNLESS SPECIFIED OTHERWISE 1PLC ±0.3 2PLC ±0.13 3PLC ±0.050 ANGLES ±1°		SIZE <b>B</b>	PROD CODE 445
MATERIAL 1		FINISH 2		DRAWING NUMBER C- 11826	REV A
<b>METRIC</b>		SCALE 10:1	CUSTOMER		SHEET 2 OF 3

### TAPE AND REEL PACKAGING

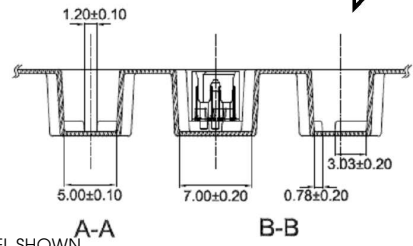
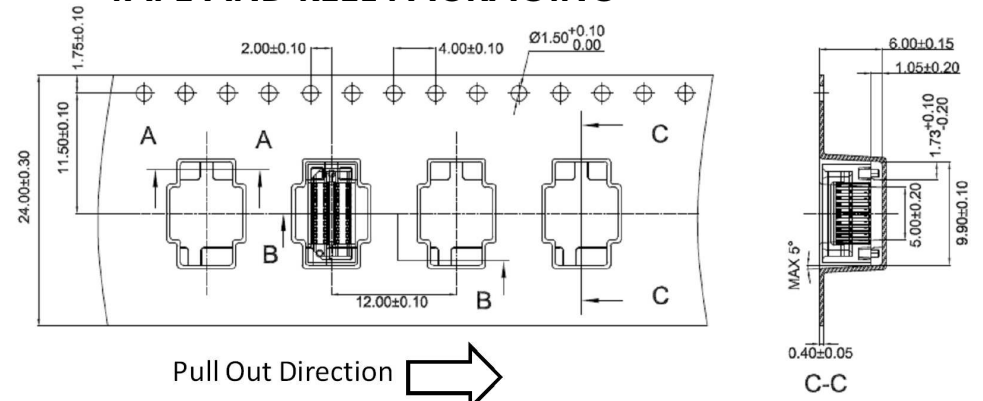

POS	TAPE WIDTH
10	24.00 +/- 0.30 MM
20	32.00 +/- 0.30 MM
30	32.00 +/- 0.30 MM
40	44.00 +/- 0.30 MM
50	56.00 +/- 0.30 MM
60	56.00 +/- 0.30 MM
70	56.00 +/- 0.30 MM

\*5MM PLUG 10 POSITION TAPE AND REEL SHOWN

### KAPTON TAPE

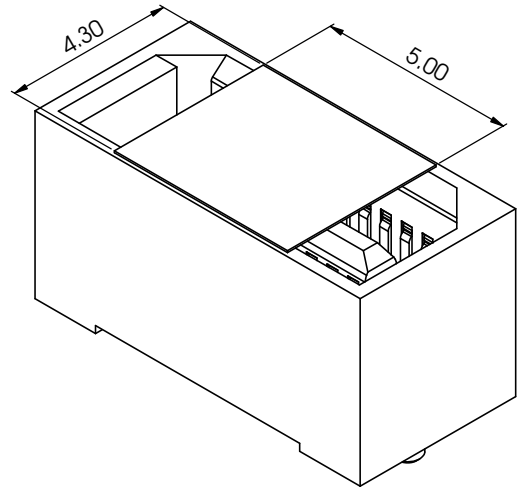

POS	LENGTH	WIDTH	THICKNESS
10	5 MM	4.3 MM	0.05 MM
20	5 MM	4.3 MM	0.05 MM
30	15 MM	4.3 MM	0.05 MM
40	15 MM	4.3 MM	0.05 MM
50	15 MM	4.3 MM	0.05 MM
60	15 MM	4.3 MM	0.05 MM
70	15 MM	4.3 MM	0.05 MM

THIS DOCUMENT CONTAINS CONFIDENTIAL AND PROPRIETARY INFORMATION OF AMPHENOL INTERCON SYSTEMS AND MAY NOT BE DISCLOSED, REPRODUCED OR OTHERWISE USED WITHOUT WRITTEN PERMISSION

**Amphenol** AMPHENOL INTERCON SYSTEMS INC.  
**InterCon Systems** Efters, PA 17319

ALL DIMENSIONS AND TOLERANCES PER ASME Y14.5M-2009  
 ALL DIMENSIONS ARE IN MILLIMETERS UNLESS OTHERWISE SPECIFIED

THIRD ANGLE PROJECTION

INSPECTION: FIRST PIECE (◇), SPC (△), IN-PROCESS (○)

TOLERANCES UNLESS SPECIFIED OTHERWISE:  
 1PLC ± 0.3  
 2PLC ± 0.13  
 3PLC ± 0.050  
 ANGLES ± 1°

NAME: **LYNX PLUG ASSEMBLY**

SIZE: **B** PROD CODE: 445 DRAWING NUMBER: C-11826 REV: A

MATERIAL: 1 FINISH: 2 SCALE: 10:1 CUSTOMER SHEET 3 OF 3

**METRIC**



Компания «ЭлектроПласт» предлагает заключение долгосрочных отношений при поставках импортных электронных компонентов на взаимовыгодных условиях!

Наши преимущества:

- Оперативные поставки широкого спектра электронных компонентов отечественного и импортного производства напрямую от производителей и с крупнейших мировых складов;
- Поставка более 17-ти миллионов наименований электронных компонентов;
- Поставка сложных, дефицитных, либо снятых с производства позиций;
- Оперативные сроки поставки под заказ (от 5 рабочих дней);
- Экспресс доставка в любую точку России;
- Техническая поддержка проекта, помощь в подборе аналогов, поставка прототипов;
- Система менеджмента качества сертифицирована по Международному стандарту ISO 9001;
- Лицензия ФСБ на осуществление работ с использованием сведений, составляющих государственную тайну;
- Поставка специализированных компонентов (Xilinx, Altera, Analog Devices, Intersil, Interpoint, Microsemi, Aeroflex, Peregrine, Syfer, Eurofarad, Texas Instrument, Miteq, Cobham, E2V, MA-COM, Hittite, Mini-Circuits, General Dynamics и др.);

Помимо этого, одним из направлений компании «ЭлектроПласт» является направление «Источники питания». Мы предлагаем Вам помощь Конструкторского отдела:

- Подбор оптимального решения, техническое обоснование при выборе компонента;
- Подбор аналогов;
- Консультации по применению компонента;
- Поставка образцов и прототипов;
- Техническая поддержка проекта;
- Защита от снятия компонента с производства.



#### Как с нами связаться

**Телефон:** 8 (812) 309 58 32 (многоканальный)

**Факс:** 8 (812) 320-02-42

**Электронная почта:** [org@eplast1.ru](mailto:org@eplast1.ru)

**Адрес:** 198099, г. Санкт-Петербург, ул. Калинина, дом 2, корпус 4, литера А.