



INTRODUCTION FLYER

Power Relay F7 A Latching

TE Connectivity presents its first bistable automotive plug-in relay in the maxi class. The power relay F7 A latching is a bistable single-coil version realized with a permanent magnet. It expands the TE bistable relay portfolio with a plug-in version in the maxi class.

Bistable relays only need a short pulse of energy applied to the coil to change the switching state. It is not necessary for power to remain applied in order to maintain the switched state. Power consumption is very significantly reduced, especially for applications that must remain switched on over a long period of time. Power relay F7 A latching and other bistable relays offer several advantages over monostable (non-latching) variants. The decreased coil power requirement in bistable relays translates to reduced temperature rise. This means at the same ambient temperature a bistable relay can conduct higher continuous current than a monostable relay. If a bistable relay and a monostable relay are carrying equal continuous currents, the bistable relay may be used at higher ambient temperature. Additionally, the vehicle's energy consumption and thus the CO₂ emissions are considerably reduced.

Given that relays consume up to 10% of a vehicle's electric power, the power relay F7 A latching offers considerable energy saving potential within the vehicle.



www.te.com • relays.te.com
<http://www.te.com/en/product-launch/f7-latching-relay.html>

 **TE** RELAY
connectivity PRODUCTS

Power Relay F7 A Latching

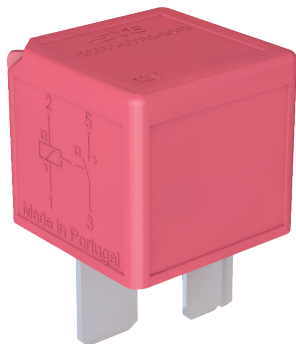

KEY FEATURES

- Magnetically latched, ISO plug-in relay
- One coil with set and reset function
- Pin assignment similar to ISO 7588 part 1
- 60A continuous current at 85°C
- Customized versions available (color, parallel or serial components etc.)
- Mini version (40A with 6.3mm terminals) available on request

MORE INFORMATION

Tyco Electronics AMP GmbH
a TE Connectivity Ltd. company
TE Relay Products
AMPèstr. 12-14
64625 Bensheim / Germany
Phone: +49-(0)6251-133-0
Fax: +49-(0)6251-133-1600

www.te.com • relays.te.com
<http://www.te.com/en/product-launch/f7-latching-relay.html>

Data Sheet Link

TE Connectivity (logo) and TE Connectivity are trademarks of the TE Connectivity group of companies and its licensors.

Other logos, product or company names mentioned herein may be trademarks of their respective owners.

Tyco Electronics AMP GmbH certified acc. ISO 14001 and ISO/TS 16949:2002

© 2012 Tyco Electronics AMP GmbH
1308002-1 EVE 1 Issued 08-2012

APPLICATIONS

- Cross carline, e.g.
 - Power outlet switch off
 - Start-stop
 - Energy management

CONTACT DATA

- Contact arrangement: 1 form A (NO) contact
- Rated voltage: 12VDC
- Limiting continuous current: 80A at 23°C, 60A at 85°C, 35A at 125°C
- Limiting making/breaking current: 300/70A
- Limiting short-time current overload current, ISO 8820-3: 1.35 x 50A, 1800s; 2.00 x 50A, 5s; 3.50 x 50A, 0.5s; 6.00 x 50A, 0.1s
- Contact material: silver based
- Set/reset time: 2/1ms
- Mechanical endurance: >1x10⁷ operations

COIL DATA

- Magnetic system: bistable, single coil system
- Rated coil voltage/power: 12VDC
- Max. coil temperature: 155°C
- Polarity for set/reset energization: - pin 2, + pin 1/- pin 1, + pin 2

INSULATION DATA

- Initial dielectric strength
 - between open contacts / contact and coil / adjacent contacts: 500Vrms

OTHER DATA

- Category of environmental protection, IEC 61810: RT1 – dustproof
- Degree of protection, IEC 60529: IP54 – dustproof
- Terminal type: Plug-in, quick connect

DIMENSIONS AND TERMINAL ASSIGNMENT

Dimensions

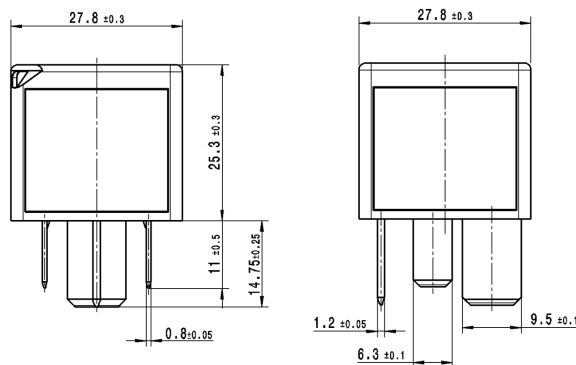

Terminal assignment

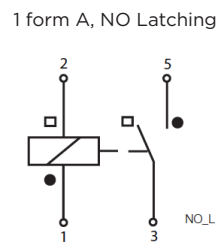

View of the terminals (bottom view)

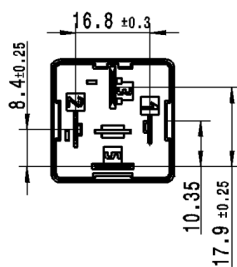

While TE has made every reasonable effort to ensure the accuracy of the information in this product flyer, TE does not guarantee that it is error-free, nor does TE make any other representation, warranty or guarantee that the information is accurate, correct, reliable or current. TE reserves the right to make any adjustments to the information contained herein at any time without notice. TE expressly disclaims all implied warranties regarding the information contained herein, including, but not limited to, any implied warranties of merchantability or fitness for a particular purpose. The dimensions in this product flyer are for reference purposes only and are subject to change without notice. Specifications are subject to change without notice. Consult TE for the latest dimensions and design specifications.



Компания «ЭлектроПласт» предлагает заключение долгосрочных отношений при поставках импортных электронных компонентов на взаимовыгодных условиях!

Наши преимущества:

- Оперативные поставки широкого спектра электронных компонентов отечественного и импортного производства напрямую от производителей и с крупнейших мировых складов;
- Поставка более 17-ти миллионов наименований электронных компонентов;
- Поставка сложных, дефицитных, либо снятых с производства позиций;
- Оперативные сроки поставки под заказ (от 5 рабочих дней);
- Экспресс доставка в любую точку России;
- Техническая поддержка проекта, помощь в подборе аналогов, поставка прототипов;
- Система менеджмента качества сертифицирована по Международному стандарту ISO 9001;
- Лицензия ФСБ на осуществление работ с использованием сведений, составляющих государственную тайну;
- Поставка специализированных компонентов (Xilinx, Altera, Analog Devices, Intersil, Interpoint, Microsemi, Aeroflex, Peregrine, Syfer, Eurofarad, Texas Instrument, Miteq, Cobham, E2V, MA-COM, Hittite, Mini-Circuits, General Dynamics и др.);

Помимо этого, одним из направлений компании «ЭлектроПласт» является направление «Источники питания». Мы предлагаем Вам помощь Конструкторского отдела:

- Подбор оптимального решения, техническое обоснование при выборе компонента;
- Подбор аналогов;
- Консультации по применению компонента;
- Поставка образцов и прототипов;
- Техническая поддержка проекта;
- Защита от снятия компонента с производства.



Как с нами связаться

Телефон: 8 (812) 309 58 32 (многоканальный)

Факс: 8 (812) 320-02-42

Электронная почта: org@eplast1.ru

Адрес: 198099, г. Санкт-Петербург, ул. Калинина, дом 2, корпус 4, литера А.