

PAGE 1/4	ISSUE 2017-03-01	SERIES EZ-Lux™	PART NUMBER F725 E00 100
----------	------------------	----------------	---------------------------------

EZ-Lux™ PLUG with boot

EZ-Lux™ was designed to be a compact, easy to mate, single channel solution for LuxCis® ARINC 801 contacts. The push-pull coupling mechanism simplifies the connection, especially in blind mating conditions.

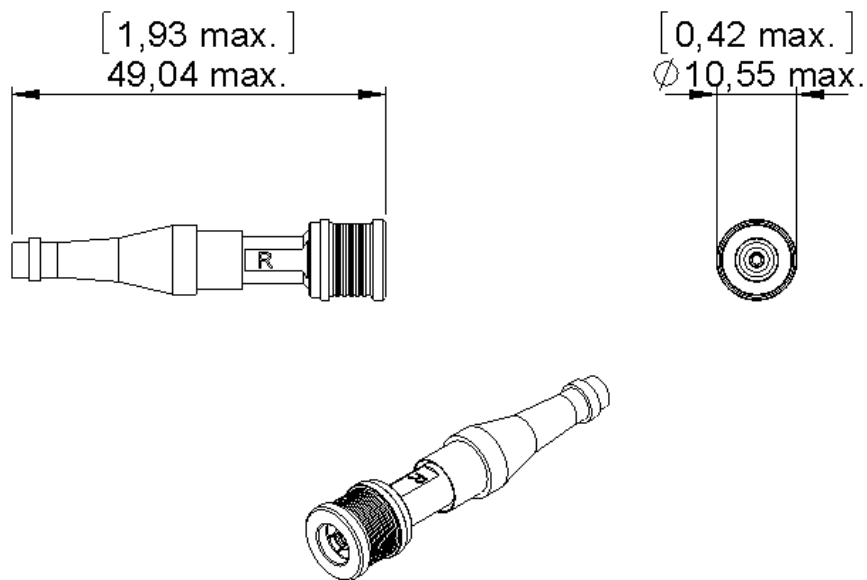

Dimensions are in mm [inches] for information only

FEATURES:

- Fast & easy to use with its push-pull locking system
- Single channel connector
- Small foot print
- Push pull coupling mechanism
- Compatible with LuxCis® Arinc 801, Multimode, Singlemode PC and APC optical contact
- Suitable for fiber optic cable diameter from 1.7mm to 2mm



PAGE 2/4	ISSUE 2017-03-01	SERIES EZ-Lux™	PART NUMBER F725 E00 100
----------	------------------	----------------	---------------------------------

CHARACTERISTICS

OPTICAL CHARACTERISTICS WITH LUXCIS® ARINC 801 CONTACT:

Optical:	LuxCis® Arinc 801 contact		
	Multimode PC 850 / 1300 nm	Singlemode UPC 1310/1550 nm	Singlemode APC 1310/1550 nm
Insertion Loss (IL) Mean: TIA/EIA-171	0.10 dB	0.15 dB	0.20 dB
Return Loss (RL): TIA/EIA-455-107	> 20 dB	> 50 dB	> 60 dB

CHARACTERISTICS:

Qualification per Arinc 801 standard:

Mechanical:	Endurance : TIA/EIA 455-21A	100 matings*
	Cable retention : EN2591-610	68 N (<i>cable dependent</i>)

Environmental:	Temperature range :	-55 °C / +125 °C (<i>cable dependent</i>)
	Sealing : TIA/EIA 455-15A	Altitude immersion 75000 feet
	Salt spray :	96 h

Material:	Disconnect nut, outer contact :	Brass. Plating : BBR 2µm
	Sleeve:	Zirconia
	Contact retention clip :	Beryllium copper
	O-ring :	Fluorisilicone elastomer
	Boot :	Fluorisilicone elastomer
	Spring:	Stainless steel
	Other parts :	Brass. Plating : Ni 2µm
	Protective caps:	Plastic and silicon

Weight:	Plug without LuxCis contact :	7 g approx. (W/O cap)
----------------	-------------------------------	-----------------------

* EZ-Lux™ has passed additional testing which demonstrates its suitability for 1,000 mating cycles.

PAGE 3/4	ISSUE 2017-03-01	SERIES EZ-Lux™	PART NUMBER F725 E00 100
----------	------------------	----------------	---------------------------------

INSERTION / EXTRACTION of LUXCIS® ARINC 801 CONTACT

Required material:

Radiall PN	Description	Picture
282 515	Size 16 (MIL-PRF-81969 / 14-03), Plastic insertion and extraction tool	

Insertion Process:

Step	Description	Pictures
1	Manually slide the sealing boot onto the cable. Leave about 10 cm between the rear of the contact and the boot.	
2	Engage the LuxCis® Arinc 801 contact mounted onto its patchcord into the blue side of the insertion tool 282 515 . Slide the tool down the cable until the tip of the tool butts against the contact's retention shoulder.	
3	Make sure the flat surface of the plug rear and the contact key are aligned before insertion. Introduce the contact into the connector cavity, pushing the tool axially, until the contact snaps into position. Remove the insertion tool and ensure that contact is firmly locked by gently pulling the patchcord.	
4	When the LuxCis® Arinc 801 contact is properly inserted and firmly locked, slide the sealing boot onto the body.	

Extraction Process:

Manually slide back the sealing boot.
Use the white side of the tool (282 515) to remove the LuxCis® Arinc 801 contact.

PAGE 4/4	ISSUE 2017-03-01	SERIES EZ-Lux™	PART NUMBER F725 E00 100
----------	------------------	----------------	--------------------------

PLUG AND RECEPTACLE COUPLING

Connection:

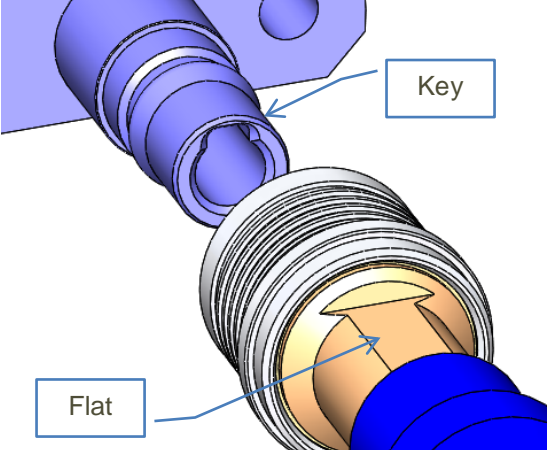
Step	Description	Pictures
1	Hold the plug by its body.	
2	Make sure the flat surface of the plug rear is aligned with the receptacle key.	
3	Push forward to mate. The connector snaps on.	

Disconnection:

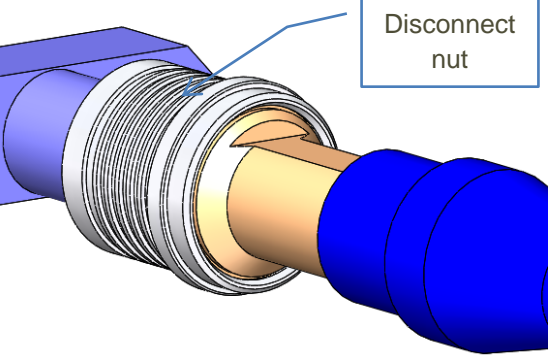
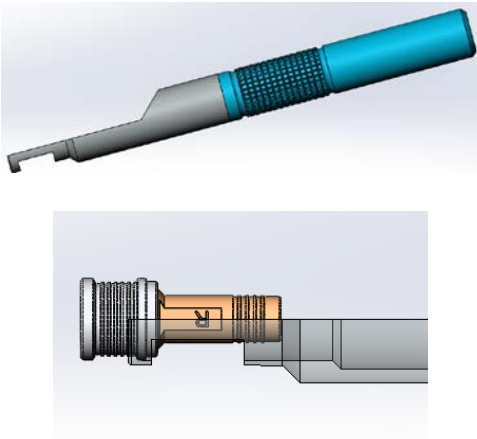
Step	Description	Pictures
1	Pull back on the disconnect nut.	
2	For high density panel, use the tool R282.868.230 to disconnect.	



Компания «ЭлектроПласт» предлагает заключение долгосрочных отношений при поставках импортных электронных компонентов на взаимовыгодных условиях!

Наши преимущества:

- Оперативные поставки широкого спектра электронных компонентов отечественного и импортного производства напрямую от производителей и с крупнейших мировых складов;
- Поставка более 17-ти миллионов наименований электронных компонентов;
- Поставка сложных, дефицитных, либо снятых с производства позиций;
- Оперативные сроки поставки под заказ (от 5 рабочих дней);
- Экспресс доставка в любую точку России;
- Техническая поддержка проекта, помощь в подборе аналогов, поставка прототипов;
- Система менеджмента качества сертифицирована по Международному стандарту ISO 9001;
- Лицензия ФСБ на осуществление работ с использованием сведений, составляющих государственную тайну;
- Поставка специализированных компонентов (Xilinx, Altera, Analog Devices, Intersil, Interpoint, Microsemi, Aeroflex, Peregrine, Syfer, Eurofarad, Texas Instrument, Miteq, Cobham, E2V, MA-COM, Hittite, Mini-Circuits, General Dynamics и др.);

Помимо этого, одним из направлений компании «ЭлектроПласт» является направление «Источники питания». Мы предлагаем Вам помощь Конструкторского отдела:

- Подбор оптимального решения, техническое обоснование при выборе компонента;
- Подбор аналогов;
- Консультации по применению компонента;
- Поставка образцов и прототипов;
- Техническая поддержка проекта;
- Защита от снятия компонента с производства.



Как с нами связаться

Телефон: 8 (812) 309 58 32 (многоканальный)

Факс: 8 (812) 320-02-42

Электронная почта: org@eplast1.ru

Адрес: 198099, г. Санкт-Петербург, ул. Калинина, дом 2, корпус 4, литера А.