

## KEELOQ<sup>®</sup> Code Hopping Decoder

### FEATURES

#### Security

- Encrypted storage of manufacturer's code
- Encrypted storage of crypt keys
- Up to seven transmitters can be learned
- KEELOQ<sup>®</sup> code hopping technology
- Normal and Secure learning mechanisms

#### Operating

- 3.0V—5.5V operation
- Internal oscillator
- Auto bit rate detection

#### Other

- Stand-alone decoder chipset
- External EEPROM for transmitter storage
- Synchronous serial interface
- 1 Kbit user EEPROM
- 8-pin DIP/SOIC package

#### Typical Applications

- Automotive remote entry systems
- Automotive alarm systems
- Automotive immobilizers
- Gate and garage openers
- Electronic door locks
- Identity tokens
- Burglar alarm systems

#### Compatible Encoders

All KEELOQ encoders and transponders configured for the following setting:

- PWM modulation format (1/3-2/3)
- TE in the range from 100us to 400us
- 10 x TE Header
- 28-bit Serial Number
- 16-bit Synchronization counter
- Discrimination bits equal to Serial Number 8 LSbs
- 66- to 69-bit length code word.

### DESCRIPTION

The Microchip Technology Inc. HCS500 is a code hopping decoder designed for secure Remote Keyless Entry (RKE) systems. The HCS500 utilizes the patented KEELOQ code hopping system and high security learning mechanisms to make this a canned solution when used with the HCS encoders to implement a uni-directional remote and access control systems. The HCS500 can be used as a stand-alone decoder or in conjunction with a microcontroller.

### PACKAGE TYPE

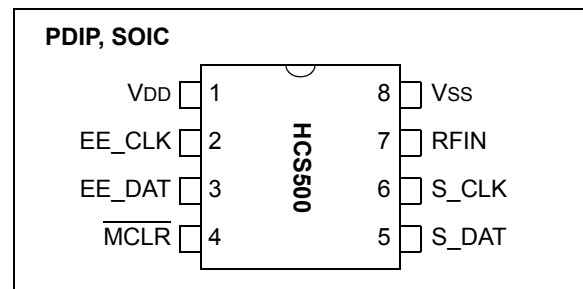

### BLOCK DIAGRAM

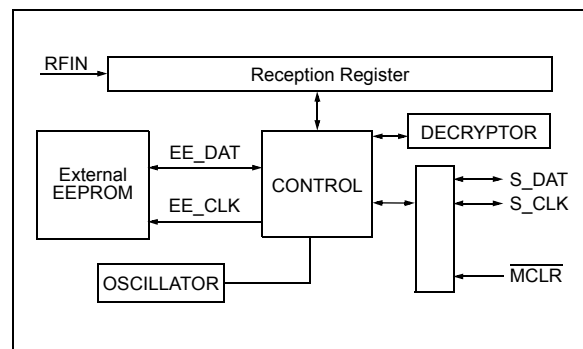

The manufacturer's code, crypt keys, and synchronization information are stored in encrypted form in external EEPROM. The HCS500 uses the S\_DAT and S\_CLK inputs to communicate with a host controller device.

The HCS500 operates over a wide voltage range of 3.0 volts to 5.5 volts. The decoder employs automatic bit-rate detection, which allows it to compensate for wide variations in transmitter data rate. The decoder contains sophisticated error checking algorithms to ensure only valid codes are accepted.

## 1.0 SYSTEM OVERVIEW

### Key Terms

The following is a list of key terms used throughout this data sheet. For additional information on KEELOQ and Code Hopping, refer to Technical Brief 3 (TB003).

- **RKE** - Remote Keyless Entry
- **Button Status** - Indicates what button input(s) activated the transmission. Encompasses the 4 button status bits S3, S2, S1 and S0 (Figure 7-2).
- **Code Hopping** - A method by which a code, viewed externally to the system, appears to change unpredictably each time it is transmitted.
- **Code word** - A block of data that is repeatedly transmitted upon button activation (Figure 7-1).
- **Transmission** - A data stream consisting of repeating code words (Figure 7-1).
- **Crypt key** - A unique and secret 64-bit number used to encrypt and decrypt data. In a symmetrical block cipher such as the KEELOQ algorithm, the encryption and decryption keys are equal and will therefore be referred to generally as the crypt key.
- **Encoder** - A device that generates and encodes data.
- **Encryption Algorithm** - A recipe whereby data is scrambled using a crypt key. The data can only be interpreted by the respective decryption algorithm using the same crypt key.
- **Decoder** - A device that decodes data received from an encoder.
- **Decryption algorithm** - A recipe whereby data scrambled by an encryption algorithm can be unscrambled using the same crypt key.
- **Learn** – Learning involves the receiver calculating the transmitter's appropriate crypt key, decrypting the received hopping code and storing the serial number, synchronization counter value and crypt key in EEPROM. The KEELOQ product family facilitates several learning strategies to be implemented on the decoder. The following are examples of what can be done.
  - **Simple Learning**  
The receiver uses a fixed crypt key, common to all components of all systems by the same manufacturer, to decrypt the received code word's encrypted portion.
  - **Normal Learning**  
The receiver uses information transmitted during normal operation to derive the crypt key and decrypt the received code word's encrypted portion.
  - **Secure Learn**  
The transmitter is activated through a special button combination to transmit a stored 60-bit seed value used to generate the transmitter's crypt key. The receiver uses this seed value

to derive the same crypt key and decrypt the received code word's encrypted portion.

- **Manufacturer's code** – A unique and secret 64-bit number used to generate unique encoder crypt keys. Each encoder is programmed with a crypt key that is a function of the manufacturer's code. Each decoder is programmed with the manufacturer code itself.

### 1.1 HCS Encoder Overview

The HCS encoders have a small EEPROM array which must be loaded with several parameters before use. The most important of these values are:

- A crypt key that is generated at the time of production
- A 16-bit synchronization counter value
- A 28-bit serial number which is meant to be unique for every encoder

The manufacturer programs the serial number for each encoder at the time of production, while the 'Key Generation Algorithm' generates the crypt key (Figure 1-1). Inputs to the key generation algorithm typically consist of the encoder's serial number and a 64-bit manufacturer's code, which the manufacturer creates.

<p><b>Note:</b> The manufacturer code is a pivotal part of the system's overall security. Consequently, all possible precautions must be taken and maintained for this code.</p>
--

**FIGURE 1-1: CREATION AND STORAGE OF CRYPT KEY DURING PRODUCTION**

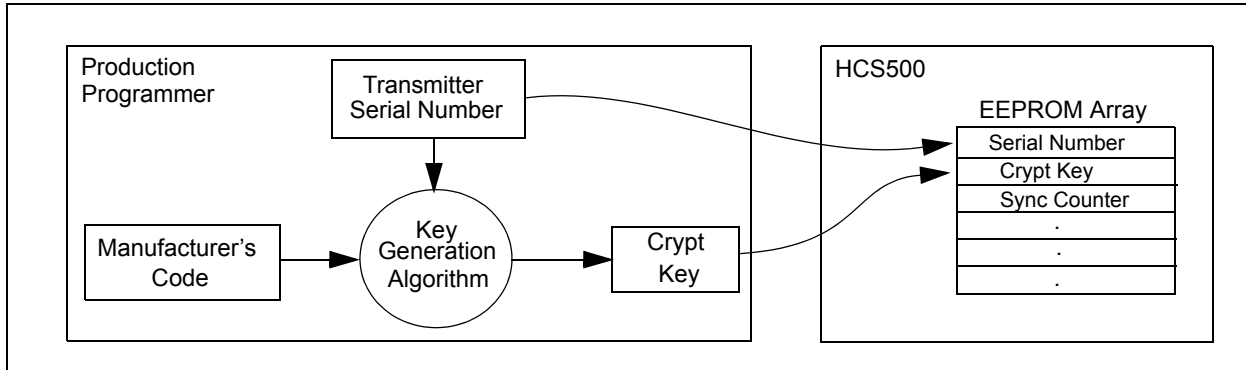

The 16-bit synchronization counter is the basis behind the transmitted code word changing for each transmission; it increments each time a button is pressed. Due to the code hopping algorithm's complexity, each increment of the synchronization value results in greater than 50% of the bits changing in the transmitted code word.

Figure 1-2 shows how the key values in EEPROM are used in the encoder. Once the encoder detects a button press, it reads the button inputs and updates the synchronization counter. The synchronization counter and crypt key are input to the encryption algorithm and the output is 32 bits of encrypted information. This data will change with every button press, its value appearing externally to 'randomly hop around', hence it is referred to as the hopping portion of the code word. The 32-bit hopping code is combined with the button information and serial number to form the code word transmitted to the receiver. The code word format is explained in greater detail in Section 7.2.

A receiver may use any type of controller as a decoder, but it is typically a microcontroller with compatible firmware that allows the decoder to operate in conjunction with an HCS500 based transmitter. Section 3.0 provides detail on integrating the HCS500 into a system.

A transmitter must first be 'learned' by the receiver before its use is allowed in the system. Learning includes calculating the transmitter's appropriate crypt key, decrypting the received hopping code and storing the serial number, synchronization counter value and crypt key in EEPROM.

In normal operation, each received message of valid format is evaluated. The serial number is used to determine if it is from a learned transmitter. If from a learned transmitter, the message is decrypted and the synchronization counter is verified. Finally, the button status is checked to see what operation is requested. Figure 1-3 shows the relationship between some of the values stored by the receiver and the values received from the transmitter.

**FIGURE 1-2: BUILDING THE TRANSMITTED CODE WORD (ENCODER)**

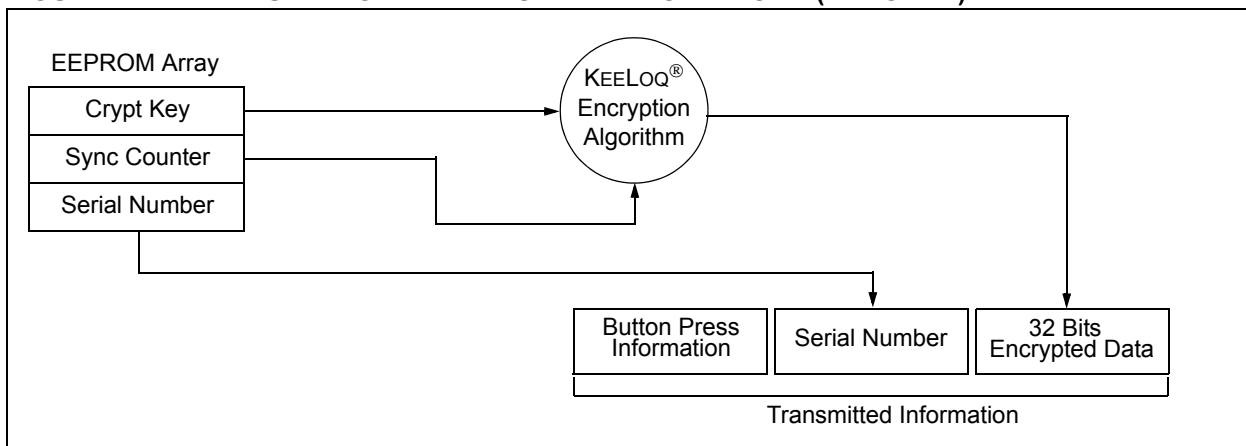

# HCS500

**FIGURE 1-3: BASIC OPERATION OF RECEIVER (DECODER)**

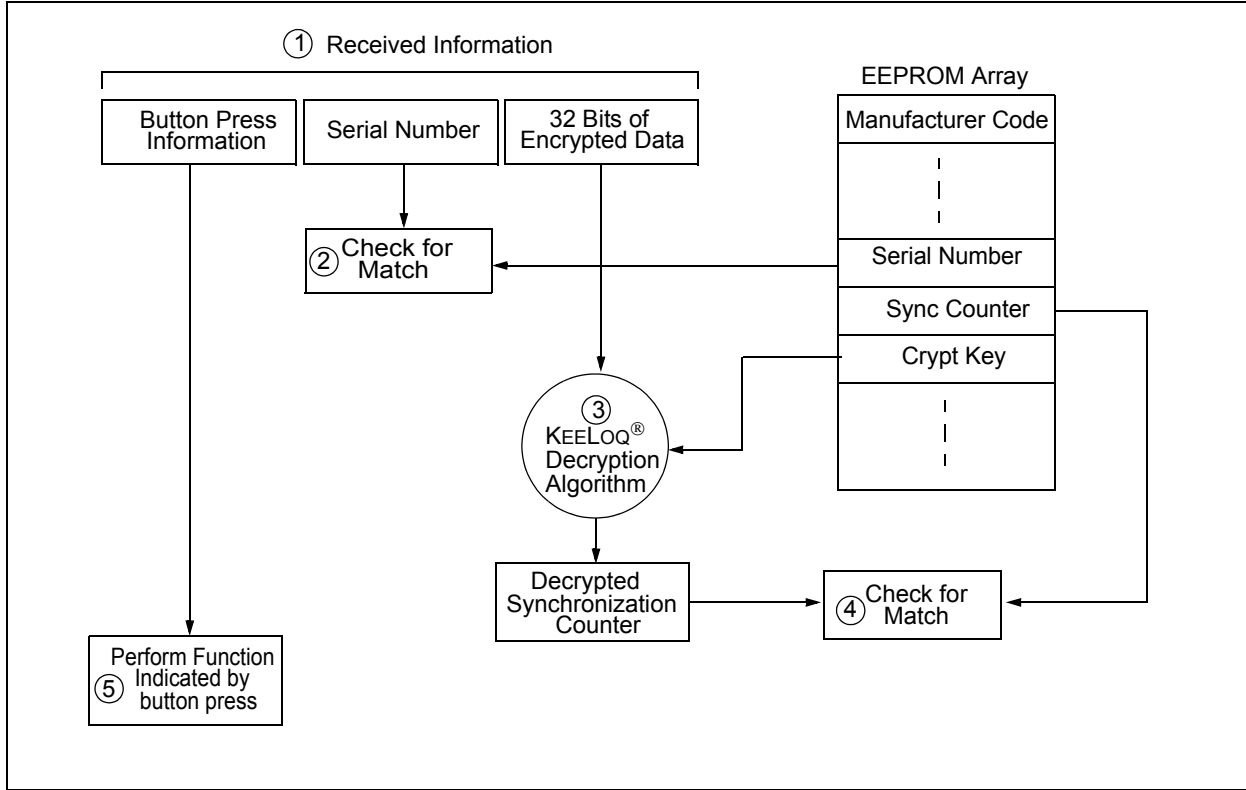

**Note:** Circled numbers indicate the order of execution.

## 2.0 PIN ASSIGNMENT

PIN	Decoder Function	I/O <sup>(1)</sup>	Buffer Type <sup>(1)</sup>	Description
1	VDD	P	—	Power Connection
2	EE_CLK	O	TTL	Clock to I <sup>2</sup> C™ EEPROM
3	EE_DAT	I/O	TTL	Data to I <sup>2</sup> C EEPROM
4	MCLR	I	ST	Master clear input
5	S_DAT	I/O	TTL	Synchronous data from controller
6	S_CLK	I	TTL	Synchronous clock from controller
7	RFIN	I	TTL	RF input from receiver
8	GND	P	—	Ground connection

**Note:** P = power, I = in, O = out, and ST = Schmitt Trigger input.

## 3.0 DECODER OPERATION

### 3.1 Learning a Transmitter to a Receiver (Normal or Secure Learn)

Before the transmitter and receiver can work together, the receiver must first 'learn' and store the following information from the transmitter in EEPROM:

- A check value of the serial number
- The crypt key
- The current synchronization counter value

The decoder must also store the manufacturer's code (Section 1.1) in protected memory. This code will typically be the same for all of the decoders in a system.

The HCS500 has seven memory slots, and, consequently, can store up to seven transmitters. During the learn procedure, the decoder searches for an empty memory slot for storing the transmitter's information. When all of the memory slots are full, the decoder will overwrite the last transmitter's information. To erase all of the memory slots at once, use the ERASE\_ALL command (C3H).

### 3.2 LEARNING PROCEDURE

Learning is initiated by sending the ACTIVATE\_LEARN (D2H) command to the decoder. The decoder acknowledges reception of the command by pulling the data line high.

For the HCS500 decoder to learn a new transmitter, the following sequence is required:

1. Activate the transmitter once.
2. Activate the transmitter a second time. (In Secure Learning mode, the seed transmission must be transmitted during the second stage of learn by activating the appropriate buttons on the transmitter.)

The HCS500 will transmit a learn-status string, indicating that the learn was successful.

3. The decoder has now learned the transmitter.
4. Repeat steps 1-3 to learn up to seven transmitters

**Note 1:** Learning will be terminated if two nonsequential codes were received or if two acceptable codes were not decoded within 30 seconds.

**2:** If more than seven transmitters are learned, the new transmitter will replace the last transmitter learned. It is, therefore, not possible to erase lost transmitters by repeatedly learning new transmitters. To remove lost or stolen transmitters, ERASE\_ALL transmitters and relearn all available transmitters.

- 3: Learning a transmitter with a crypt key that is identical to a transmitter already in memory replaces the existing transmitter. In practice, this means that all transmitters should have unique crypt keys. Learning a previously learned transmitter does not use any additional memory slots.

The following checks are performed by the decoder to determine if the transmission is valid during learn:

- The first code word is checked for bit integrity.
- The second code word is checked for bit integrity.
- The crypt key is generated according to the selected algorithm.
- The hopping code is decrypted.
- The discrimination value is checked.
- If all the checks pass, the key, serial number check value, and synchronization counter values are stored in EEPROM memory.

Figure 3-1 shows a flow chart of the learn sequence.

**FIGURE 3-1: LEARN SEQUENCE**

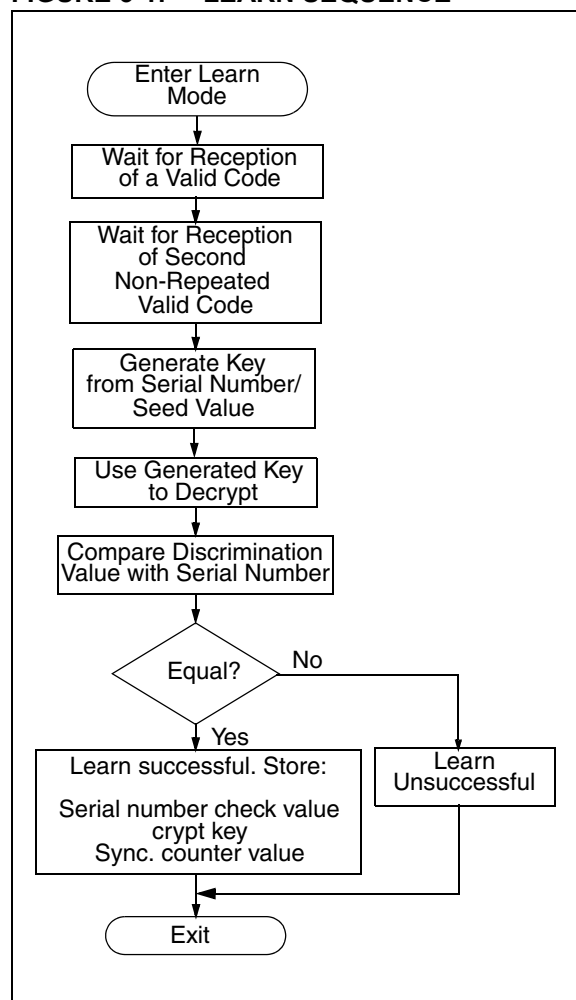

## 3.3 Validation of Codes

The decoder waits for a transmission and checks the serial number to determine if it is a learned transmitter. If it is, it takes the code hopping portion of the transmission and decrypts it, using the crypt key. It uses the discrimination value to determine if the decryption was valid. If everything up to this point is valid, the synchronization counter value is evaluated.

## 3.4 Validation Steps

Validation consists of the following steps:

1. Search EEPROM to find the Serial Number Check Value Match
2. Decrypt the Hopping Code
3. Compare the 10 bits of the discrimination value with the lower 10 bits of serial number
4. Check if the synchronization counter value falls within the first synchronization window.
5. Check if the synchronization counter value falls within the second synchronization window.
6. If a valid transmission is found, update the synchronization counter, else use the next transmitter block, and repeat the tests.

FIGURE 3-2: DECODER OPERATION

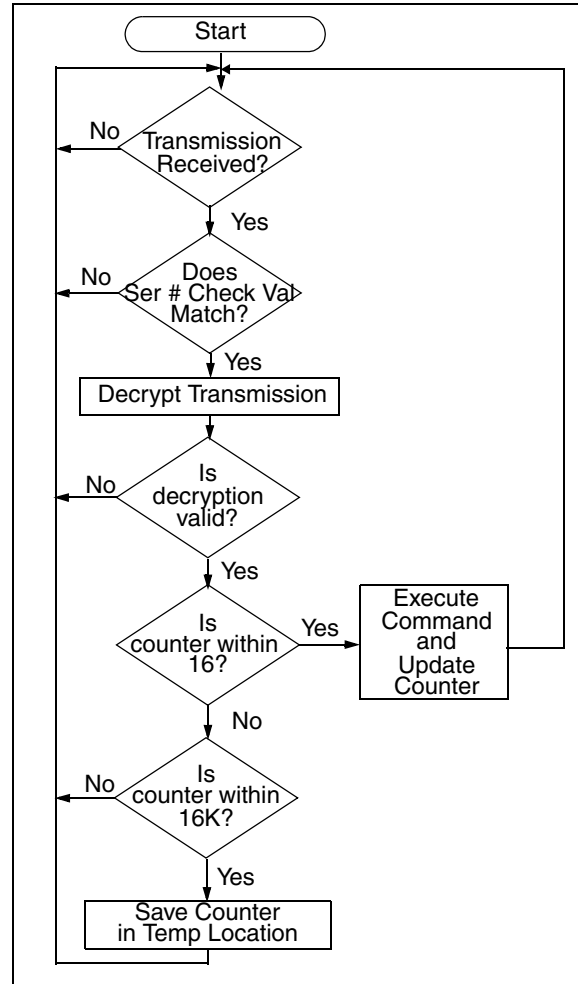

### 3.5 Synchronization with Decoder (Evaluating the Counter)

The KEELOQ technology patent scope includes a sophisticated synchronization technique that does not require the calculation and storage of future codes. The technique securely blocks invalid transmissions while providing transparent resynchronization to transmitters inadvertently activated away from the receiver.

Figure 3-3 shows a 3-partition, rotating synchronization window. The size of each window is optional but the technique is fundamental. Each time a transmission is authenticated, the intended function is executed and the transmission's synchronization counter value is stored in EEPROM. From the currently stored counter value there is an initial "Single Operation" forward window of 16 codes. If the difference between a received synchronization counter and the last stored counter is within 16, the intended function will be executed on the single button press and the new synchronization counter will be stored. Storing the new synchronization counter value effectively rotates the entire synchronization window.

A "Double Operation" (resynchronization) window further exists from the Single Operation window up to 32K codes forward of the currently stored counter value. It is referred to as "Double Operation" because a transmission with synchronization counter value in this window will require an additional, sequential counter transmission prior to executing the intended function. Upon receiving the sequential transmission the decoder executes the intended function and stores the synchronization counter value. This resynchronization occurs transparently to the user as it is human nature to press the button a second time if the first was unsuccessful.

The third window is a "Blocked Window" ranging from the double operation window to the currently stored synchronization counter value. Any transmission with synchronization counter value within this window will be ignored. This window excludes previously used, perhaps code-grabbed transmissions from accessing the system.

**FIGURE 3-3: SYNCHRONIZATION WINDOW**

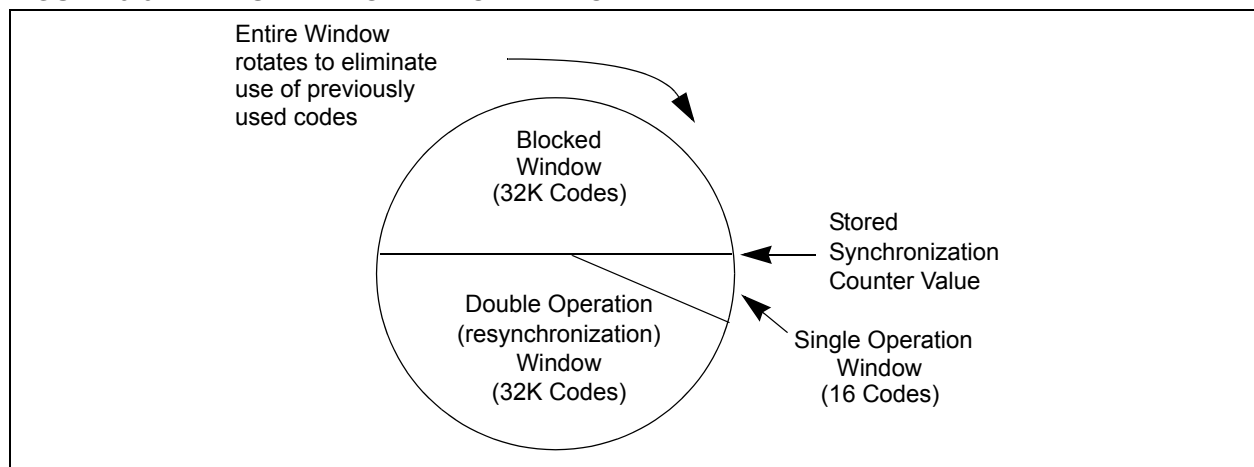

# HCS500

## 4.0 INTERFACING TO A MICROCONTROLLER

The HCS500 interfaces to a microcontroller via a synchronous serial interface. A clock and data line are used to communicate with the HCS500. The microcontroller controls the clock line. There are two groups of data transfer messages. The first is from the decoder whenever the decoder receives a valid transmission. The decoder signals reception of a valid code by taking the data line high (maximum of 500 ms). The microcontroller then services the request by clocking out a data string from the decoder. The data string contains the function code, the status bit, and block indicators. The second is from the controlling microcontroller to the decoder in the form of a defined command set.

Figure 4-1 shows the HCS500 decoder and the I/O interface lines necessary to interface to a microcontroller.

### 4.1 Valid Transmission Message

The decoder informs the microcontroller of a valid transmission by taking the data line high for up to 500 ms. The controlling microcontroller must acknowl-

edge by taking the clock line high. The decoder then takes the data line low. The microcontroller can then begin clocking a data stream out of the HCS500. The data stream consists of:

- START bit '0'.
- 2 status bits [REPEAT, VLOW].
- 4-bit function code [S3 S2 S1 S0].
- STOP bit '1'.
- 4 bits indicating which block was used [TX3...TX0].
- 4 bits indicating the number of transmitters learned into the decoder [CNT3...CNT0].
- 64 bits of the received transmission with the hopping code decrypted.

**Note:** Data is always clocked in/out Least Significant Bit (LSB) first.

The decoder will terminate the transmission of the data stream at any point where the clock is kept low for longer than 1 ms. Therefore, the microcontroller can only clock out the required bits. A maximum of 80 bits can be clocked out of the decoder.

FIGURE 4-1: HCS500 DECODER AND I/O INTERFACE LINES

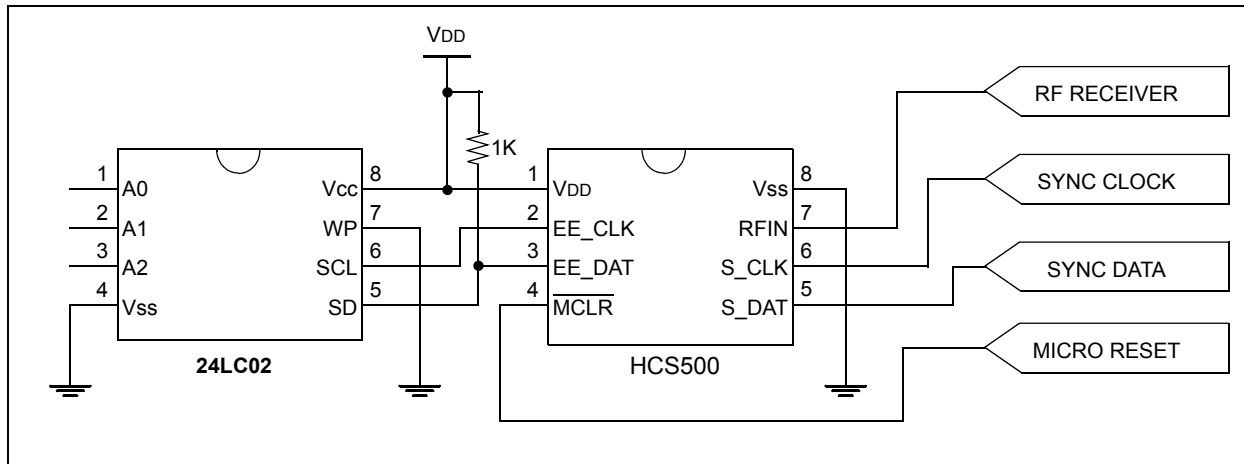
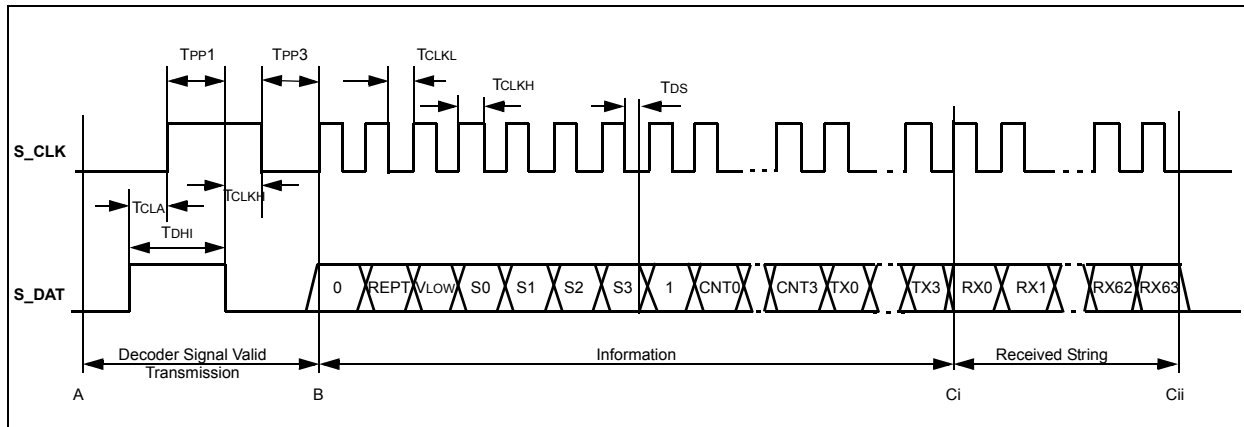

FIGURE 4-2: DECODER VALID TRANSMISSION MESSAGE





## 4.2 Command Mode

### 4.2.1 MICROCONTROLLER COMMAND MODE ACTIVATION

The microcontroller command consists of four parts. The first part activates the Command mode, the second part is the actual command, the third is the address accessed, and the last part is the data. The microcontroller starts the command by taking the clock line high for up to 500 ms. The decoder acknowledges the start-up sequence by taking the data line high. The microcontroller takes the clock line low, after which the decoder will take the data line low, tri-state the data line and wait for the command to be clock in. The data must be set up on the rising edge and will be sampled on the falling edge of the clock line.

### 4.2.2 COLLISION DETECTION

The HCS500 uses collision detection to prevent clashes between the decoder and microcontroller. Whenever the decoder receives a valid transmission the following sequence is followed:

- The decoder first checks to see if the clock line is high. If the clock line is high, the valid transmission notification is aborted, and the microcontroller Command mode request is serviced.
- The decoder takes the data line high and checks that the clock line doesn't go high within 50  $\mu$ s. If the clock line goes high, the valid transmission notification is aborted and the Command mode request is serviced.
- If the clock line goes high after 50  $\mu$ s but before 500 ms, the decoder will acknowledge by taking the data line low.
- The microcontroller can then start to clock out the 80-bit data stream of the received transmission.

**FIGURE 4-3: MICROCONTROLLER COMMAND MODE ACTIVATION**

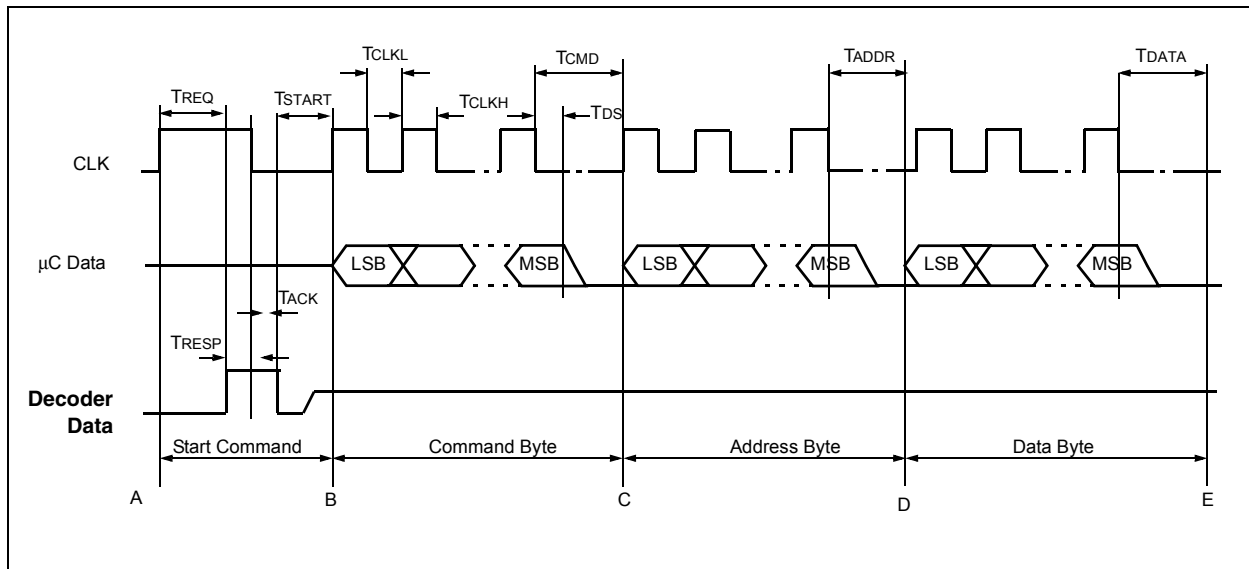

# HCS500

## 4.2.3 COMMAND ACTIVATION TIMES

The command activation time (Table 4-1) is defined as the maximum time the microcontroller has to wait for a response from the decoder. The decoder will abort and service the command request. The response time depends on the state of the decoder when the Command mode is requested.

## 4.2.4 DECODER COMMANDS

The command byte specifies the operation required by the controlling microcontroller. Table 4-2 lists the commands.

**TABLE 4-1: COMMAND ACTIVATION TIMES**

Decoder State	Min	Max
While receiving transmissions	—	2.5 ms BPW <sub>MAX</sub> = 2.7 ms
During the validation of a received transmission	—	3 ms
During the update of the sync counters	—	40 ms
During learn	—	170 ms

\* These parameters are characterized but not tested.

**TABLE 4-2: DECODER COMMANDS**

Instruction	Command Byte	Operation
READ	F0 <sub>16</sub>	Read a byte from user EEPROM
WRITE	E1 <sub>16</sub>	Write a byte to user EEPROM
ACTIVATE_LRN	D2 <sub>16</sub>	Activate a learn sequence on the decoder
ERASE_ALL	C3 <sub>16</sub>	Activate an erase all function on the decoder
PROGRAM	B4 <sub>16</sub>	Program manufacturer's code and configuration byte

## 4.2.5 READ BYTE/S FROM USER EEPROM

The read command (Figure 4-4) is used to read bytes from the user EEPROM. The offset in the user EEPROM is specified by the address byte which is truncated to seven bits (C to D). After the address, a dummy byte must be clocked in (D to E). The EEPROM data byte is clocked out on the next rising edge of the clock line with the Least Significant bit first (E to F). Sequential reads are possible by repeating sequence E to F within 1 ms after the falling edge of the previous byte's Most Significant Bit (MSB) bit. During the sequential read, the address value will wrap after 128 bytes. The decoder will terminate the read command if no clock pulses are received for a period longer than 1.2 ms.

## 4.2.6 WRITE BYTE/S TO USER EEPROM

The write command (Figure 4-5) is used to write a location in the user EEPROM. The address byte is truncated to seven bits (C to D). The data is clocked in Least Significant bit first. The clock line must be asserted to initiate the write. Sequential writes of bytes are possible by clocking in the byte and then asserting the clock line (D – F). The decoder will terminate the write command if no clock pulses are received for a period longer than 1.2 ms. After a successful write sequence the decoder will acknowledge by taking the data line high and keeping it high until the clock line goes low.

**FIGURE 4-4: READ BYTES FROM USER EEPROM**

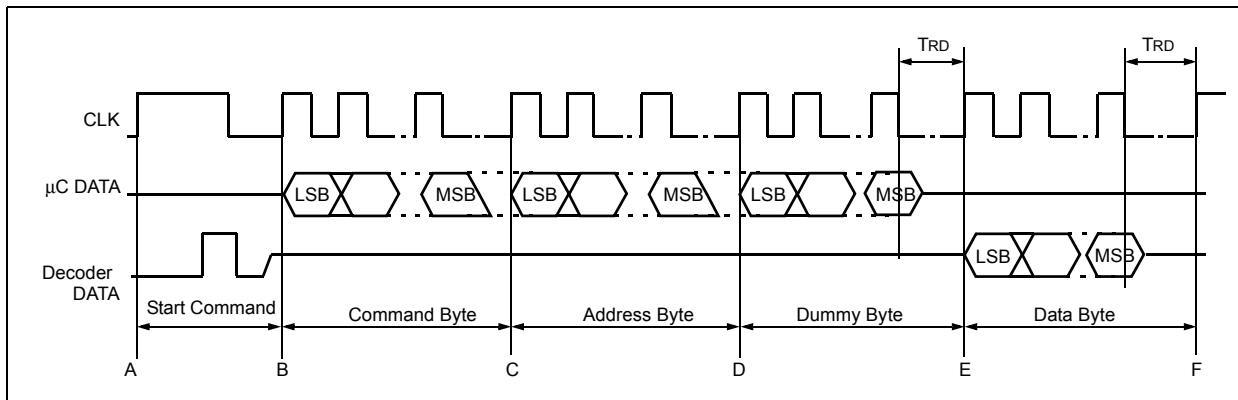

**FIGURE 4-5: WRITE BYTES TO USER EEPROM**

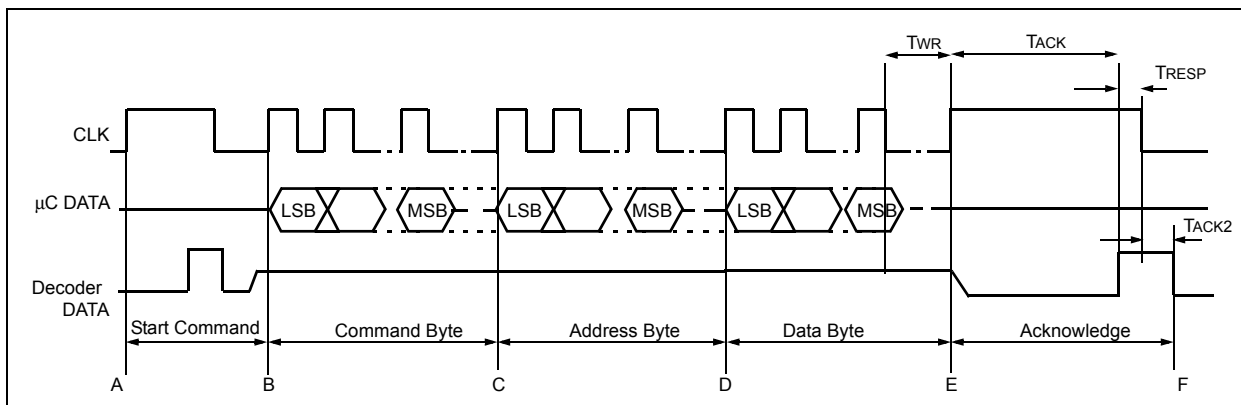

## 4.2.7 ACTIVATE LEARN

The activate learn command (Figure 4-6) is used to activate a transmitter learning sequence on the decoder. The command consists of a Command mode activation sequence, a command byte, and two dummy bytes. The decoder will respond by taking the data line high to acknowledge that the command was valid and that learn is active.

Upon reception of the first transmission, the decoder will respond with a learn status message (Figure 4-7).

During learn, the decoder will acknowledge the reception of the first transmission by taking the data line high for 60 ms. The controlling microcontroller can clock out at most eight bits, which will all be zeros. All of the bits of the status byte are zero, and this is used to distinguish between a learn time-out status string and the first transmission received string. The controlling microcontroller must ensure that the clock line does not go high 60 ms after the falling edge of the data line, for this will terminate learn.

Upon reception of the second transmission, the decoder will respond with a learn status message (Figure 4-8).

The learn status message after the second transmission consists of the following:

- 1 START bit.
- The function code [S3:S0] of the message is zero, indicating that this is a status string.
- The RESULT bit indicates the result of the learn sequence. The RESULT bit is set if successful and cleared otherwise.
- The OVR bit will indicate whether an exiting transmitter is over written. The OVR bit will be set if an existing transmitter is learned over.
- The [CNT3...CNT0] bits will indicate the number of transmitters learned on the decoder.
- The [TX3...TX0] bits indicate the block number used during the learning of the transmitter.

**FIGURE 4-6: LEARN MODE ACTIVATION**

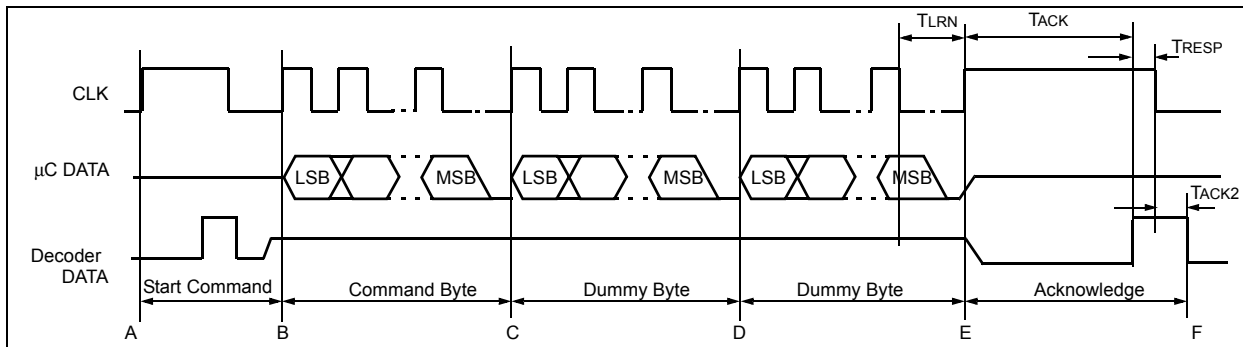

**FIGURE 4-7: LEARN STATUS MESSAGE AFTER FIRST TRANSMISSION**

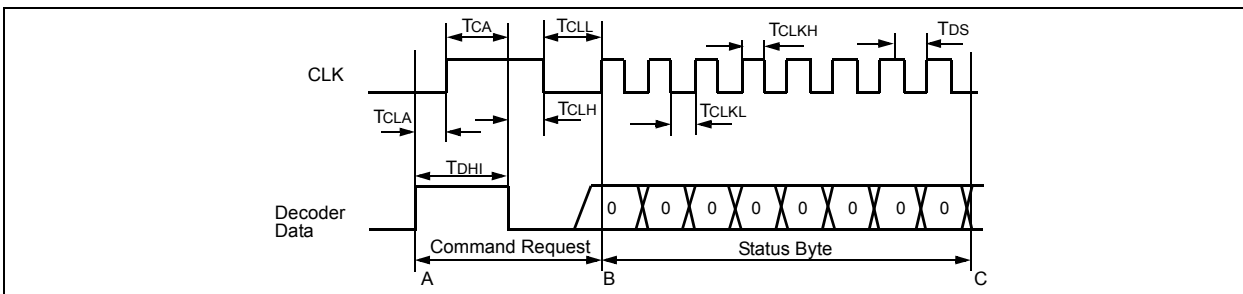

**FIGURE 4-8: LEARN STATUS MESSAGE AFTER SECOND TRANSMISSION**

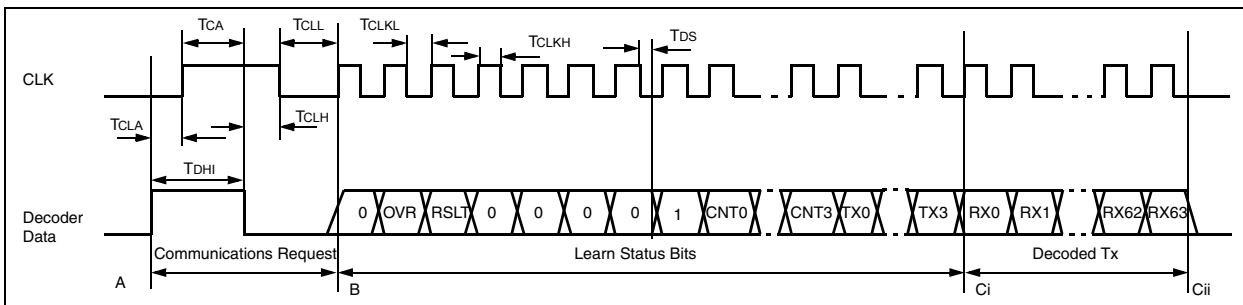

## 4.2.8 ERASE ALL

The erase all command (Figure 4-9) erases all the transmitters in the decoder. After the command and two dummy bytes are clocked in, the clock line must be asserted to activate the command. After a successful completion of an erase all command, the data line is asserted until the clock line goes low.

## 4.3 Stand-alone Mode

The HCS500 decoder can also be used in stand-alone applications. The HCS500 will activate the data line for up to 500 ms if a valid transmission was received, and this output can be used to drive a relay circuit. To activate learn or erase all commands, a button must be connected to the CLK input. User feedback is indicated on an LED connected to the DATA output line. If the CLK line is pulled high, using the learn button, the LED will switch on. After the CLK line is kept high for longer than 2 seconds, the decoder will switch the LED line off, indicating that learn will be entered if the button is released. If the CLK line is kept high for another 6 seconds, the decoder will activate an ERASE\_ALL Command.

Learn mode can be aborted by taking the clock line high until the data line goes high (LED switches on). During learn, the data line will give feedback to the user and, therefore, must not be connected to the relay drive circuitry.

**Note:** The REPS bit must be cleared in the configuration byte in Stand-alone mode.

After taking the clock low and before a transmitter is learn, any low-to-high change on the clock line may terminate learn. This has learn implications when a switch with contact bounce is used.

## 4.4 Erase All Command and Erase Command

The Table 4-3 describes two versions of the Erase All command.

**TABLE 4-3: ERASE ALL COMMAND**

Command Byte	Subcommand Byte	Description
C3 <sub>16</sub>	00 <sub>16</sub>	Erase all transmitters.
C3 <sub>16</sub>	01 <sub>16</sub>	Erase all transmitters except 1. The first transmitter in memory is not erased.

Subcommand 01 can be used where a transmitter with permanent status is implemented in the microcontroller software. Use of subcommand 01 ensures that the permanent transmitter remains in memory even when all

other transmitters are erased. The first transmitter learned after any of the following events is the first transmitter in memory and becomes the permanent transmitter:

1. Programming of the manufacturer's code.
2. Erasing of all transmitters (subcommand 00 only).

## 4.5 Test mode

A special test mode is activated after:

1. Programming of the manufacturer's code.
2. Erasing of all transmitters.

Test mode can be used to test a decoder before any transmitters are learned on it. Test mode enables testing of decoders without spending the time to learn a transmitter. Test mode is terminated after the first successful learning of an ordinary transmitter. In test mode, the decoder responds to a test transmitter. The test transmitter has the following properties:

1. crypt key = manufacturer's code.
2. Serial number = any value.
3. Discrimination bits = lower 10 bits of the serial number.
4. Synchronization counter value = any value (synchronization information is ignored).

Because the synchronization counter value is ignored in test mode, any number of test transmitters can be used, even if their synchronization counter values are different.

## 4.6 Power Supply Supervisor

Reliable operation of the HCS500 requires that the contents of the EEPROM memory be protected against erroneous writes. To ensure that erroneous writes do not occur after supply voltage "brown-out" conditions, the use of a proper power supply supervisor device (like Microchip part MCP100-450) is imperative.

# HCS500

**FIGURE 4-9: ERASE ALL**

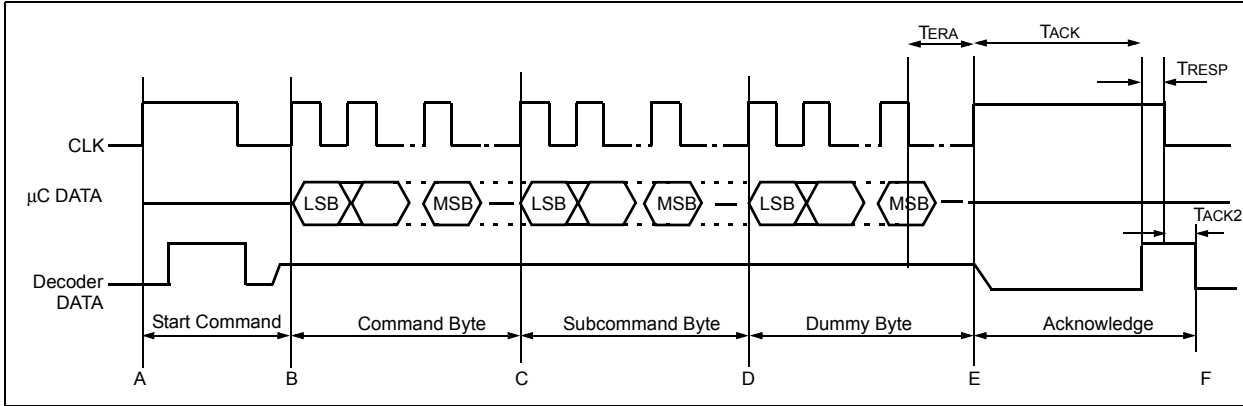

**FIGURE 4-10: STAND-ALONE MODE LEARN/ERASE-ALL TIMING**

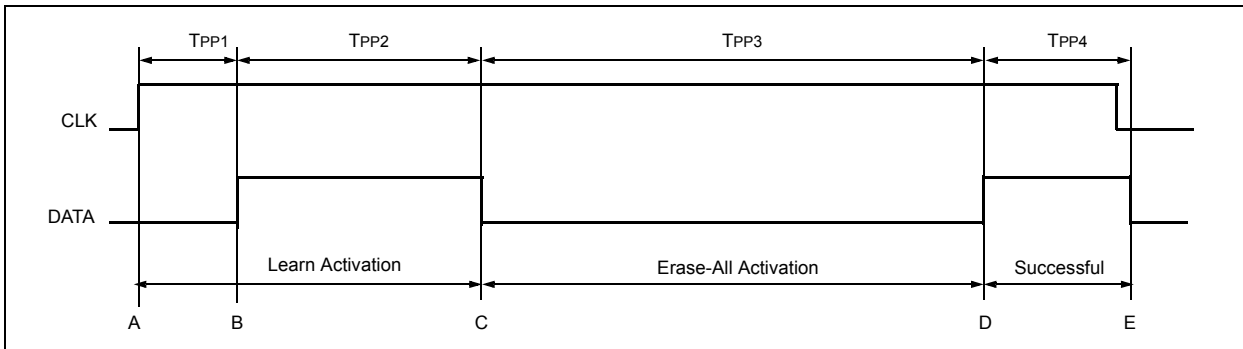

**FIGURE 4-11: TYPICAL STAND-ALONE APPLICATION CIRCUIT**

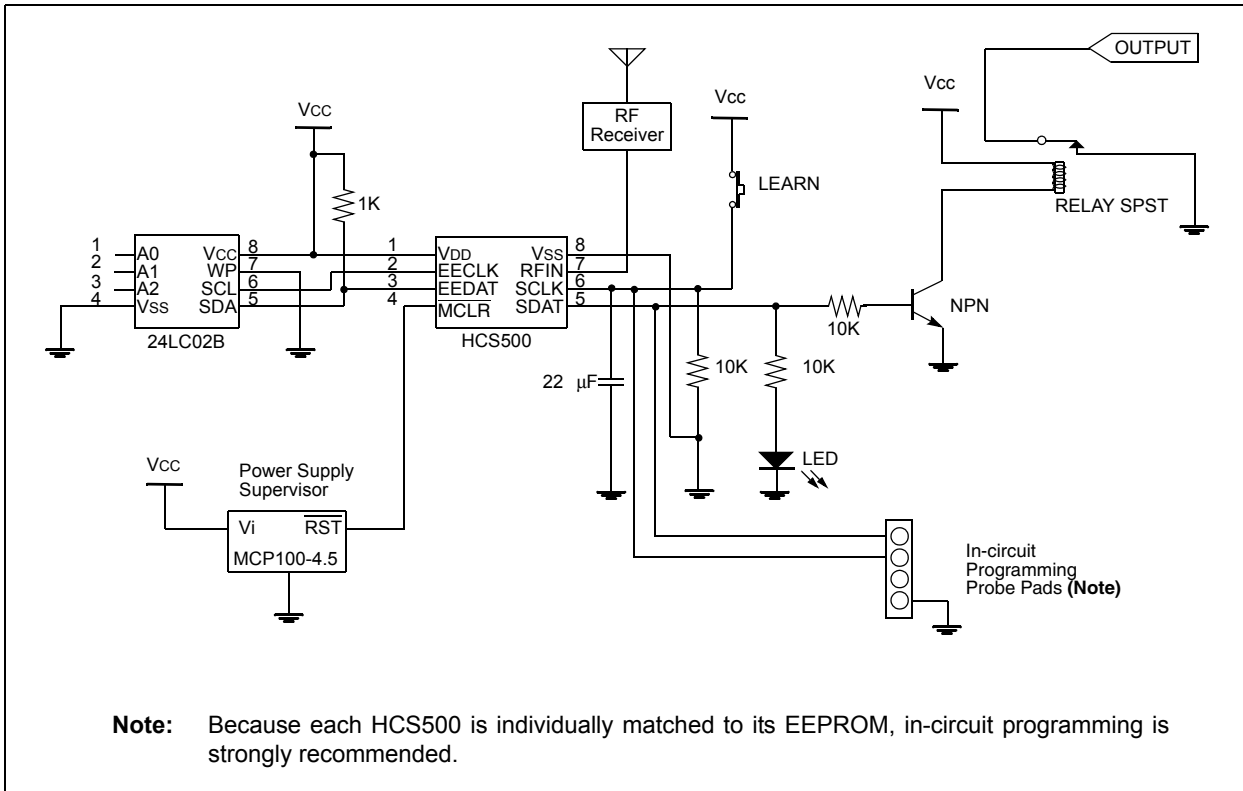

**Note:** Because each HCS500 is individually matched to its EEPROM, in-circuit programming is strongly recommended.

## 5.0 DECODER PROGRAMMING

The decoder uses a 2K, 24LC02B serial EEPROM. The memory is divided between system memory that stores the transmitter information (read protected) and user memory (read/write). Commands to access the user memory are described in Sections 4.2.5 and 4.2.6.

The following information stored in system memory needs to be programmed before the decoder can be used:

- 64-bit manufacturer's code
- Decoder configuration byte

**Note 1:** These memory locations are read protected and can only be written to using the program command with the device powered up.

**2:** The contents of the system memory is encrypted by a unique 64-bit key that is stored in the HCS500. To initialize the system memory, the HCS500's program command must be used. The EEPROM and HCS500 are matched, and the devices must be kept together. In-circuit programming is therefore recommended.

### 5.1 Configuration Byte

The decoder is configured during initialization by setting the appropriate bits in the configuration byte. The following table list the options:

Bit	Mnemonic	Description
0	LRN_MODE	Learning mode selection LRN_MODE = 0—Normal Learn LRN_MODE = 1—Secure Learn
1	LRN_ALG	Algorithm selection LRN_ALG = 0—KEELOQ Decryption Algorithm LRN_ALG = 1—XOR Algorithm
2	REPEAT	Repeat Transmission enable 0 = Disable 1 = Enabled
3	Not Used	Reserved
4	Not Used	Reserved
5	Not Used	Reserved
6	Not Used	Reserved
7	Not Used	Reserved

#### 5.1.1 LRN\_MODE

LRN\_MODE selects between two learning modes. With LRN\_MODE = 0, the Normal (serial number derived) mode is selected; with LRN\_MODE=1, the Secure (seed derived) mode is selected. See Section 6.0 for more detail on learning modes.

#### 5.1.2 LRN\_ALG

LRN\_ALG selects between the two available algorithms. With LRN\_ALG = 0, is selected the KEELOQ decryption algorithm is selected; with LRN\_ALG = 1, the XOR algorithm is selected. See Section 6.0 for more detail on learning algorithms.

#### 5.1.3 REPEAT

The HCS500 can be configured to indicate repeated transmissions. In a stand-alone configuration, repeated transmissions must be disabled.

## 5.2 Programming Waveform

The programming command consists of the following:

- Command Request Sequence (A to B)
- Command Byte (B to C)
- Configuration Byte (C to D)
- Manufacturer's Code Eight Data Bytes (D to G)
- Activation and Acknowledge Sequence (G to H)

## 5.3 Programming Data String

A total of 80 bits are clocked into the decoder. The 8-bit command byte is clocked in first, followed by the 8-bit configuration byte and the 64-bit manufacturer's code. The data must be clocked in Least Significant Bit (LSB) first. The decoder will then encrypt the manufacturer's code using the decoder's unique 64-bit EEPROM crypt key. After completion of the programming EEPROM, the decoder will acknowledge by taking the data line high (G to H). If the data line goes high within 30 ms after the clock goes high, programming also fails.

**FIGURE 5-1: PROGRAMMING WAVEFORM**

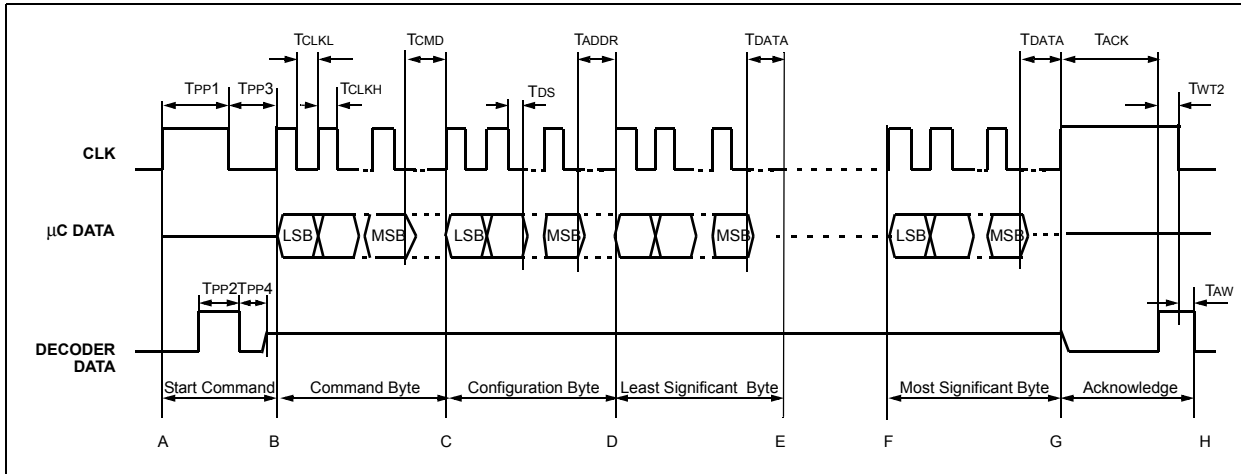



## 6.0 KEY GENERATION

The HCS500 supports three learning schemes which are selected during the initialization of the system EEPROM. The learning schemes are:

- Normal learn using the KEELOQ decryption algorithm
- Secure learn using the KEELOQ decryption algorithm
- Secure learn using the XOR algorithm

### 6.1 Normal (Serial Number derived) Learn using the KEELOQ Decryption Algorithm

This learning scheme uses the KEELOQ decryption algorithm and the 28-bit serial number of the transmitter to derive the crypt key. The 28-bit serial number is patched with predefined values as indicated below to form two 32-bit seeds.

$$\begin{aligned} \text{SourceH} &= 60000000\ 00000000\text{H} + \text{Serial Number} \mid_{28\ \text{Bits}} \\ \text{SourceL} &= 20000000\ 00000000\text{H} + \text{Serial Number} \mid_{28\ \text{Bits}} \end{aligned}$$

Then, using the KEELOQ decryption algorithm and the manufacturer's code the crypt key is derived as follows:

$$\begin{aligned} \text{KeyH}_{\text{Upper 32 bits}} &= F_{\text{KEELOQ Decryption}}(\text{SourceH}) \mid_{64\text{-Bit Manufacturer's Code}} \\ \text{KeyL}_{\text{Lower 32 bits}} &= F_{\text{KEELOQ Decryption}}(\text{SourceL}) \mid_{64\text{-Bit Manufacturer's Code}} \end{aligned}$$

### 6.2 Secure (Seed Derived) Learn using the KEELOQ Decryption Algorithm

This scheme uses the secure seed transmitted by the encoder to derive the two input seeds. The decoder always uses the lower 64 bits of the transmission to form a 60-bit seed. The upper 4 bits are always forced to zero.

**For 32-bit seed encoders (HCS200, HCS201, HCS300, HCS301):**

$$\begin{aligned} \text{SourceH} &= \text{Serial Number}_{\text{Lower 28 bits}} \\ \text{SourceL} &= \text{Seed}_{32\ \text{bits}} \end{aligned}$$

**For 48-bit seed encoders (HCS360, HCS361):**

$$\begin{aligned} \text{SourceH} &= \text{Serial Number (with upper 4 bits set to zero)}_{\text{Upper 16 bits}} \ll 16 + \text{Seed}_{\text{Upper 16 bits}} \\ \text{SourceL} &= \text{Seed}_{\text{Lower 32 bits}} \end{aligned}$$

**For 60-bit seed encoders (HCS362, HCS365, HCS370, HCS410, HCS412, HCS473):**

$$\begin{aligned} \text{SourceH} &= \text{Seed}_{\text{Upper 32 bits (with upper 4 bits set to zero)}} \\ \text{SourceL} &= \text{Seed}_{\text{Lower 32 bits}} \end{aligned}$$

The KEELOQ decryption algorithm and the manufacturer's code is used to derive the crypt key as follows:

$$\begin{aligned} \text{KeyH}_{\text{Upper 32 bits}} &= \text{Decrypt}(\text{SourceH})_{64\ \text{Bit Manufacturer's Code}} \\ \text{KeyL}_{\text{Lower 32 bits}} &= \text{Decrypt}(\text{SourceL})_{64\ \text{Bit Manufacturer's Code}} \end{aligned}$$

### 6.3 Secure (Seed Derived) Learn using the XOR Algorithm

This scheme uses the seed transmitted by the encoder to derive the two input seeds. The decoder always use the lower 64 bits of the transmission to form a 60-bit seed. The upper 4 bits are always forced to zero.

**For 32-bit seed encoders (HCS200, HCS201, HCS300, HCS301):**

$$\begin{aligned} \text{SourceH} &= \text{Serial Number}_{\text{Lower 28 bits}} \\ \text{SourceL} &= \text{Seed}_{32\ \text{bits}} \end{aligned}$$

**For 48-bit seed encoders (HCS360/HCS361):**

$$\begin{aligned} \text{SourceH} &= \text{Serial Number (with upper 4 bits set to zero)}_{\text{Upper 16 bits}} \ll 16 + \text{Seed}_{\text{Upper 16 bits}} \\ \text{SourceL} &= \text{Seed}_{\text{Lower 32 bits}} \end{aligned}$$

**For 60-bit seed encoders (HCS362, HCS365, HCS370, HCS410, HCS412, HCS473):**

$$\begin{aligned} \text{SourceH} &= \text{Seed}_{\text{Upper 32 bits with upper 4 bits set to zero}} \\ \text{SourceL} &= \text{Seed}_{\text{Lower 32 bits}} \end{aligned}$$

Then, using the manufacturer's code the crypt key is derived as follows:

$$\begin{aligned} \text{KeyH}_{\text{Upper 32 bits}} &= \text{SourceH XOR}_{64\text{-Bit Manufacturer's Code}}_{\text{Upper 32 bits}} \\ \text{KeyL}_{\text{Lower 32 bits}} &= \text{SourceL XOR}_{64\text{-Bit Manufacturer's Code}}_{\text{Lower 32 bits}} \end{aligned}$$

# HCS500

## 7.0 KEELOQ ENCODERS

### 7.1 Transmission Format (PWM)

The KEELOQ encoder transmission is made up of several parts (Figure 7-1). Each transmission begins with a preamble and a header, followed by the encrypted and then the fixed data. The actual data is 66/69 bits which consists of 32 bits of encrypted data and 34/35 bits of non-encrypted data. Each transmission is followed by a guard period before another transmission can begin. The code hopping portion provides up to four billion changing code combinations and includes the button status bits (based on which buttons were activated), along with the synchronization counter value and some discrimination bits. The non-code hopping portion is comprised of the status bits, the function

bits, and the 28-bit serial number. The encrypted and non-encrypted combined sections increase the number of combinations to  $7.38 \times 10^{19}$ .

### 7.2 Code Word Organization

The HCS encoder transmits a 66/69-bit code word when a button is pressed. The 66/69-bit word is constructed from a code hopping portion and a non-code hopping portion (Figure 7-2).

The **Encrypted Data** is generated from four button bits, two overflow counter bits, ten discrimination bits, and the 16-bit synchronization counter value.

The **Non-encrypted Data** is made up from 2 status bits, 4 function bits, and the 28/32-bit serial number.

FIGURE 7-1: TRANSMISSION FORMAT (PWM)

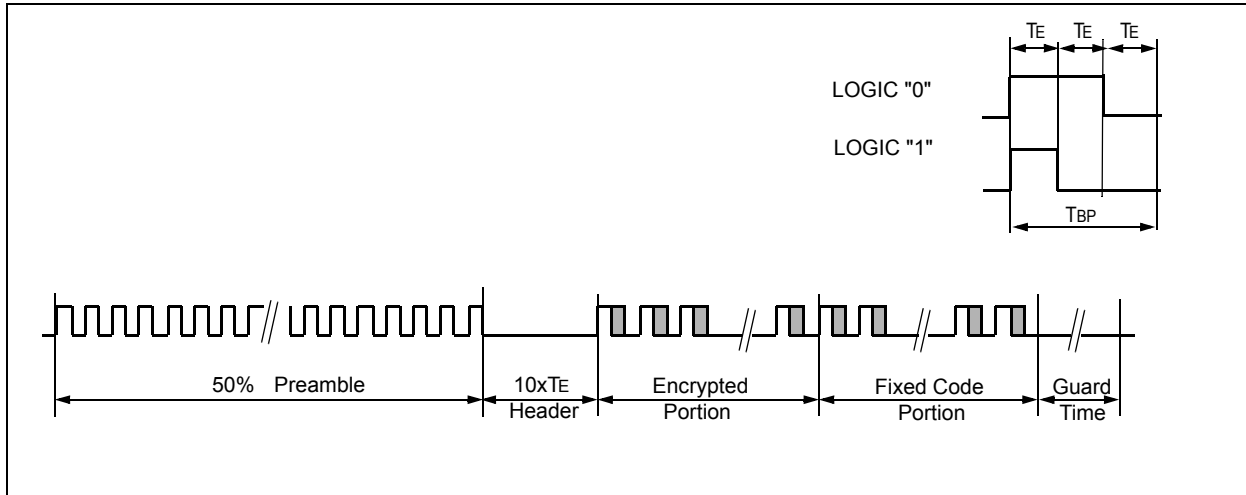
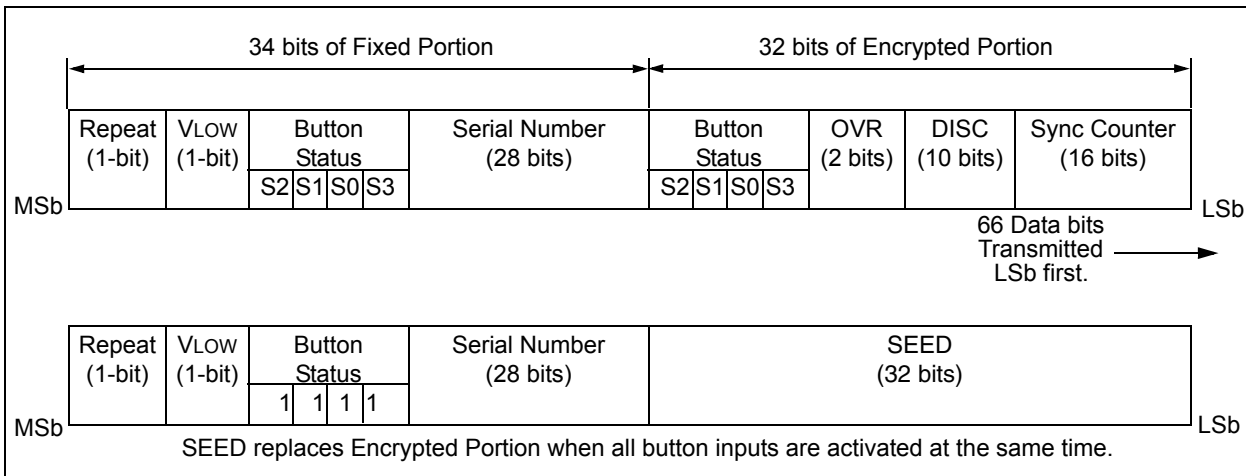

FIGURE 7-2: CODE WORD ORGANIZATION



## 8.0 DEVELOPMENT SUPPORT

The PIC<sup>®</sup> microcontrollers and dsPIC<sup>®</sup> digital signal controllers are supported with a full range of software and hardware development tools:

- Integrated Development Environment
  - MPLAB<sup>®</sup> IDE Software
- Compilers/Assemblers/Linkers
  - MPLAB C Compiler for Various Device Families
  - HI-TECH C for Various Device Families
  - MPASM<sup>™</sup> Assembler
  - MPLINK<sup>™</sup> Object Linker/  
MPLIB<sup>™</sup> Object Librarian
  - MPLAB Assembler/Linker/Librarian for Various Device Families
- Simulators
  - MPLAB SIM Software Simulator
- Emulators
  - MPLAB REAL ICE<sup>™</sup> In-Circuit Emulator
- In-Circuit Debuggers
  - MPLAB ICD 3
  - PICKit<sup>™</sup> 3 Debug Express
- Device Programmers
  - PICKit<sup>™</sup> 2 Programmer
  - MPLAB PM3 Device Programmer
- Low-Cost Demonstration/Development Boards, Evaluation Kits, and Starter Kits

## 8.1 MPLAB Integrated Development Environment Software

The MPLAB IDE software brings an ease of software development previously unseen in the 8/16/32-bit microcontroller market. The MPLAB IDE is a Windows<sup>®</sup> operating system-based application that contains:

- A single graphical interface to all debugging tools
  - Simulator
  - Programmer (sold separately)
  - In-Circuit Emulator (sold separately)
  - In-Circuit Debugger (sold separately)
- A full-featured editor with color-coded context
- A multiple project manager
- Customizable data windows with direct edit of contents
- High-level source code debugging
- Mouse over variable inspection
- Drag and drop variables from source to watch windows
- Extensive on-line help
- Integration of select third party tools, such as IAR C Compilers

The MPLAB IDE allows you to:

- Edit your source files (either C or assembly)
- One-touch compile or assemble, and download to emulator and simulator tools (automatically updates all project information)
- Debug using:
  - Source files (C or assembly)
  - Mixed C and assembly
  - Machine code

MPLAB IDE supports multiple debugging tools in a single development paradigm, from the cost-effective simulators, through low-cost in-circuit debuggers, to full-featured emulators. This eliminates the learning curve when upgrading to tools with increased flexibility and power.

## 8.2 MPLAB C Compilers for Various Device Families

The MPLAB C Compiler code development systems are complete ANSI C compilers for Microchip's PIC18, PIC24 and PIC32 families of microcontrollers and the dsPIC30 and dsPIC33 families of digital signal controllers. These compilers provide powerful integration capabilities, superior code optimization and ease of use.

For easy source level debugging, the compilers provide symbol information that is optimized to the MPLAB IDE debugger.

## 8.3 HI-TECH C for Various Device Families

The HI-TECH C Compiler code development systems are complete ANSI C compilers for Microchip's PIC family of microcontrollers and the dsPIC family of digital signal controllers. These compilers provide powerful integration capabilities, omniscient code generation and ease of use.

For easy source level debugging, the compilers provide symbol information that is optimized to the MPLAB IDE debugger.

The compilers include a macro assembler, linker, pre-processor, and one-step driver, and can run on multiple platforms.

## 8.4 MPASM Assembler

The MPASM Assembler is a full-featured, universal macro assembler for PIC10/12/16/18 MCUs.

The MPASM Assembler generates relocatable object files for the MPLINK Object Linker, Intel® standard HEX files, MAP files to detail memory usage and symbol reference, absolute LST files that contain source lines and generated machine code and COFF files for debugging.

The MPASM Assembler features include:

- Integration into MPLAB IDE projects
- User-defined macros to streamline assembly code
- Conditional assembly for multi-purpose source files
- Directives that allow complete control over the assembly process

## 8.5 MPLINK Object Linker/ MPLIB Object Librarian

The MPLINK Object Linker combines relocatable objects created by the MPASM Assembler and the MPLAB C18 C Compiler. It can link relocatable objects from precompiled libraries, using directives from a linker script.

The MPLIB Object Librarian manages the creation and modification of library files of precompiled code. When a routine from a library is called from a source file, only the modules that contain that routine will be linked in with the application. This allows large libraries to be used efficiently in many different applications.

The object linker/library features include:

- Efficient linking of single libraries instead of many smaller files
- Enhanced code maintainability by grouping related modules together
- Flexible creation of libraries with easy module listing, replacement, deletion and extraction

## 8.6 MPLAB Assembler, Linker and Librarian for Various Device Families

MPLAB Assembler produces relocatable machine code from symbolic assembly language for PIC24, PIC32 and dsPIC devices. MPLAB C Compiler uses the assembler to produce its object file. The assembler generates relocatable object files that can then be archived or linked with other relocatable object files and archives to create an executable file. Notable features of the assembler include:

- Support for the entire device instruction set
- Support for fixed-point and floating-point data
- Command line interface
- Rich directive set
- Flexible macro language
- MPLAB IDE compatibility

## 8.7 MPLAB SIM Software Simulator

The MPLAB SIM Software Simulator allows code development in a PC-hosted environment by simulating the PIC<sup>®</sup> MCUs and dsPIC<sup>®</sup> DSCs on an instruction level. On any given instruction, the data areas can be examined or modified and stimuli can be applied from a comprehensive stimulus controller. Registers can be logged to files for further run-time analysis. The trace buffer and logic analyzer display extend the power of the simulator to record and track program execution, actions on I/O, most peripherals and internal registers.

The MPLAB SIM Software Simulator fully supports symbolic debugging using the MPLAB C Compilers, and the MPASM and MPLAB Assemblers. The software simulator offers the flexibility to develop and debug code outside of the hardware laboratory environment, making it an excellent, economical software development tool.

## 8.8 MPLAB REAL ICE In-Circuit Emulator System

MPLAB REAL ICE In-Circuit Emulator System is Microchip's next generation high-speed emulator for Microchip Flash DSC and MCU devices. It debugs and programs PIC<sup>®</sup> Flash MCUs and dsPIC<sup>®</sup> Flash DSCs with the easy-to-use, powerful graphical user interface of the MPLAB Integrated Development Environment (IDE), included with each kit.

The emulator is connected to the design engineer's PC using a high-speed USB 2.0 interface and is connected to the target with either a connector compatible with in-circuit debugger systems (RJ11) or with the new high-speed, noise tolerant, Low-Voltage Differential Signal (LVDS) interconnection (CAT5).

The emulator is field upgradable through future firmware downloads in MPLAB IDE. In upcoming releases of MPLAB IDE, new devices will be supported, and new features will be added. MPLAB REAL ICE offers significant advantages over competitive emulators including low-cost, full-speed emulation, run-time variable watches, trace analysis, complex breakpoints, a ruggedized probe interface and long (up to three meters) interconnection cables.

## 8.9 MPLAB ICD 3 In-Circuit Debugger System

MPLAB ICD 3 In-Circuit Debugger System is Microchip's most cost effective high-speed hardware debugger/programmer for Microchip Flash Digital Signal Controller (DSC) and microcontroller (MCU) devices. It debugs and programs PIC<sup>®</sup> Flash microcontrollers and dsPIC<sup>®</sup> DSCs with the powerful, yet easy-to-use graphical user interface of MPLAB Integrated Development Environment (IDE).

The MPLAB ICD 3 In-Circuit Debugger probe is connected to the design engineer's PC using a high-speed USB 2.0 interface and is connected to the target with a connector compatible with the MPLAB ICD 2 or MPLAB REAL ICE systems (RJ-11). MPLAB ICD 3 supports all MPLAB ICD 2 headers.

## 8.10 PICkit 3 In-Circuit Debugger/Programmer and PICkit 3 Debug Express

The MPLAB PICkit 3 allows debugging and programming of PIC<sup>®</sup> and dsPIC<sup>®</sup> Flash microcontrollers at a most affordable price point using the powerful graphical user interface of the MPLAB Integrated Development Environment (IDE). The MPLAB PICkit 3 is connected to the design engineer's PC using a full speed USB interface and can be connected to the target via an Microchip debug (RJ-11) connector (compatible with MPLAB ICD 3 and MPLAB REAL ICE). The connector uses two device I/O pins and the reset line to implement in-circuit debugging and In-Circuit Serial Programming™.

The PICkit 3 Debug Express include the PICkit 3, demo board and microcontroller, hookup cables and CDROM with user's guide, lessons, tutorial, compiler and MPLAB IDE software.

## 8.11 PICkit 2 Development Programmer/Debugger and PICkit 2 Debug Express

The PICkit™ 2 Development Programmer/Debugger is a low-cost development tool with an easy to use interface for programming and debugging Microchip's Flash families of microcontrollers. The full featured Windows® programming interface supports baseline (PIC10F, PIC12F5xx, PIC16F5xx), midrange (PIC12F6xx, PIC16F), PIC18F, PIC24, dsPIC30, dsPIC33, and PIC32 families of 8-bit, 16-bit, and 32-bit microcontrollers, and many Microchip Serial EEPROM products. With Microchip's powerful MPLAB Integrated Development Environment (IDE) the PICkit™ 2 enables in-circuit debugging on most PIC® microcontrollers. In-Circuit-Debugging runs, halts and single steps the program while the PIC microcontroller is embedded in the application. When halted at a breakpoint, the file registers can be examined and modified.

The PICkit 2 Debug Express include the PICkit 2, demo board and microcontroller, hookup cables and CDRom with user's guide, lessons, tutorial, compiler and MPLAB IDE software.

## 8.12 MPLAB PM3 Device Programmer

The MPLAB PM3 Device Programmer is a universal, CE compliant device programmer with programmable voltage verification at VDDMIN and VDDMAX for maximum reliability. It features a large LCD display (128 x 64) for menus and error messages and a modular, detachable socket assembly to support various package types. The ICSP™ cable assembly is included as a standard item. In Stand-Alone mode, the MPLAB PM3 Device Programmer can read, verify and program PIC devices without a PC connection. It can also set code protection in this mode. The MPLAB PM3 connects to the host PC via an RS-232 or USB cable. The MPLAB PM3 has high-speed communications and optimized algorithms for quick programming of large memory devices and incorporates an MMC card for file storage and data applications.

## 8.13 Demonstration/Development Boards, Evaluation Kits, and Starter Kits

A wide variety of demonstration, development and evaluation boards for various PIC MCUs and dsPIC DSCs allows quick application development on fully functional systems. Most boards include prototyping areas for adding custom circuitry and provide application firmware and source code for examination and modification.

The boards support a variety of features, including LEDs, temperature sensors, switches, speakers, RS-232 interfaces, LCD displays, potentiometers and additional EEPROM memory.

The demonstration and development boards can be used in teaching environments, for prototyping custom circuits and for learning about various microcontroller applications.

In addition to the PICDEM™ and dsPICDEM™ demonstration/development board series of circuits, Microchip has a line of evaluation kits and demonstration software for analog filter design, KEELOQ® security ICs, CAN, IrDA®, PowerSmart battery management, SEEVAL® evaluation system, Sigma-Delta ADC, flow rate sensing, plus many more.

Also available are starter kits that contain everything needed to experience the specified device. This usually includes a single application and debug capability, all on one board.

Check the Microchip web page ([www.microchip.com](http://www.microchip.com)) for the complete list of demonstration, development and evaluation kits.

# HCS500

## 9.0 ELECTRICAL CHARACTERISTICS

### Absolute Maximum Ratings†

Ambient temperature under bias .....	-40 °C to +125 °C
Storage temperature .....	-65 °C to +150 °C
Voltage on any pin with respect to VSS (except VDD).....	-0.6V to VDD +0.6V
Voltage on VDD with respect to Vss.....	0 to +7.5V
Total power dissipation ( <b>Note</b> ).....	700 mW
Maximum current out of VSS pin .....	200 mA
Maximum current into VDD pin .....	150 mA
Input clamp current, I <sub>IK</sub> (V <sub>I</sub> < 0 or V <sub>I</sub> > V <sub>DD</sub> ) .....	± 20 mA
Output clamp current, I <sub>OK</sub> (V <sub>O</sub> < 0 or V <sub>O</sub> > V <sub>DD</sub> ) .....	± 20 mA
Maximum output current sunk by any I/O pin.....	25 mA
Maximum output current sourced by any I/O pin.....	25 mA

**Note:** Power dissipation is calculated as follows:  $P_{DIS} = V_{DD} \times \{I_{DD} - \sum I_{OH}\} + \sum \{(V_{DD} - V_{OH}) \times I_{OH}\} + \sum V_{OL} \times I_{OL}$

† **NOTICE:** Stresses above those listed under “Absolute Maximum Ratings” may cause permanent damage to the device. This is a stress rating only and functional operation of the device at those or any other conditions above those indicated in the operation listings of this specification is not implied. Exposure to maximum rating conditions for extended periods may affect device reliability.

# HCS500

**TABLE 9-1: DC CHARACTERISTICS**

		<b>Standard Operating Conditions (unless otherwise stated)</b>				
		Operating temperature Commercial (C): $0^{\circ}\text{C} \leq T_A \leq +70^{\circ}\text{C}$ Industrial (I): $-40^{\circ}\text{C} \leq T_A \leq +85^{\circ}\text{C}$				
Symbol	Parameters	Min	Typ <sup>(†)</sup>	Max	Units	Conditions
VDD	Supply voltage	3.0	—	5.5	V	
VPOR	VDD start voltage to ensure RESET	—	VSS	—	V	
SVDD	VDD rise rate to ensure RESET	0.05*	—	—	V/ms	
IDD	Supply current	—	1.8	2.4	mA	FOSC = 4 MHz, VDD = 5.5V SLEEP mode (no RF input)
		—	0.3	5	μA	
IPD	Power-Down Current	—	0.25	4	μA	VDD = 3.0V, Commercial
		—	0.3	5	μA	VDD = 3.0V, Industrial
VIL	Input low voltage	VSS	—	0.8	V	VDD between 4.5V and 5.5V
		VSS	—	0.15 VDD	V	Otherwise
		VSS	—	0.15 VDD	V	MCLR
VIH	Input high voltage	2.0	—	VDD	V	VDD between 4.5V and 5.5V
		0.25 VDD + 0.8	—	VDD	V	Otherwise
		0.85 VDD	—	VDD	V	MCLR
VOL	Output low voltage	—	—	0.6	V	IOL = 8.7 mA, VDD = 4.5V
VOH	Output high voltage	VDD - 0.7	—	—	V	IOH = -5.4 mA, VDD = 4.5V

† Data in “Typ” column is at 5.0V, 25° C unless otherwise stated. These parameters are for design guidance only and are not tested.

\* These parameters are characterized but not tested.

**Note:** Negative current is defined as coming out of the pin.

**TABLE 9-2: AC CHARACTERISTICS**

		<b>Standard Operating Conditions (unless otherwise specified):</b>				
		Commercial (C): $0^{\circ}\text{C} \leq T_A \leq +70^{\circ}\text{C}$ Industrial (I): $-40^{\circ}\text{C} \leq T_A \leq +85^{\circ}\text{C}$				
Symbol	Parameters	Min	Typ	Max	Units	Conditions
TE	Transmit elemental period	65	—	660	μs	
TOD	Output delay	48	75	237	ms	
TMCLR	MCLR low time	150	—	—	ns	
TOV	Time output valid	—	150	222	ms	

\* These parameters are characterized but not tested.



**FIGURE 9-1: RESET WATCHDOG TIMER, OSCILLATOR START-UP TIMER AND POWER-UP TIMER TIMING**

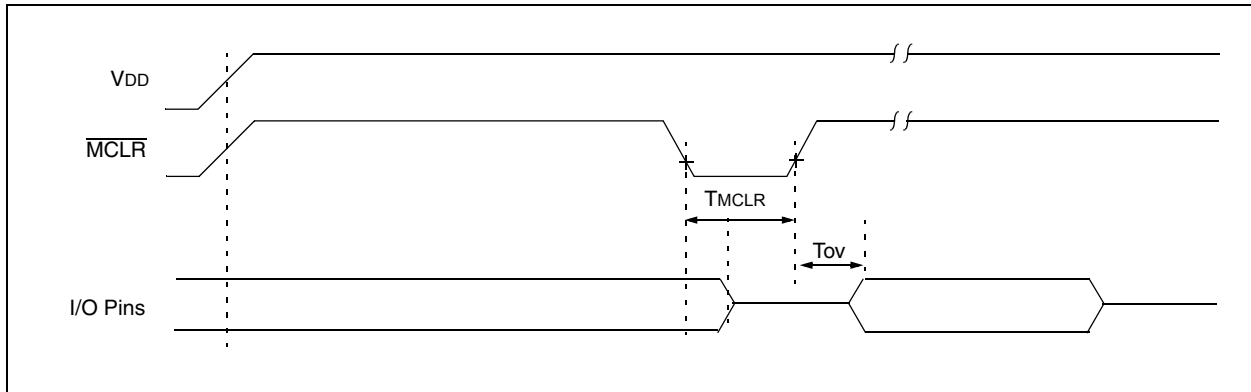

# HCS500

## 9.1 AC Electrical Characteristics

### 9.1.1 COMMAND MODE ACTIVATION

		<b>Standard Operating Conditions (unless otherwise specified):</b> Commercial (C): $0^{\circ}\text{C} \leq T_A \leq +70^{\circ}\text{C}$ Industrial (I): $-40^{\circ}\text{C} \leq T_A \leq +85^{\circ}\text{C}$			
Symbol	Parameters	Min	Typ	Max	Units
TREQ	Command request time	0.0150	—	500	ms
TRESP	Microcontroller request acknowledge time	—	—	1	ms
TACK	Decoder acknowledge time	—	—	30	$\mu\text{s}$
TSTART	Start Command mode to first command bit	20	—	1000	$\mu\text{s}$
TCLKH	Clock high time	20	—	1000	$\mu\text{s}$
TCLKL	Clock low time	20	—	1000	$\mu\text{s}$
FCLK	Clock frequency	500	—	25000	Hz
TDS	Data hold time	14	—	—	$\mu\text{s}$
TCMD	Command validate time	—	—	10	$\mu\text{s}$
TADDR	Address validate time	—	—	10	$\mu\text{s}$
TDATA	Data validate time	—	—	10	$\mu\text{s}$

\* These parameters are characterized but not tested.

### 9.1.2 READ FROM USER EEPROM COMMAND

		<b>Standard Operating Conditions (unless otherwise specified):</b> Commercial (C): $0^{\circ}\text{C} \leq T_A \leq +70^{\circ}\text{C}$ Industrial (I): $-40^{\circ}\text{C} \leq T_A \leq +85^{\circ}\text{C}$			
Symbol	Parameters	Min	Typ	Max	Units
TRD	Decoder EEPROM read time	400	—	1500	$\mu\text{s}$

\* These parameters are characterized but not tested.

### 9.1.3 WRITE TO USER EEPROM COMMAND

		<b>Standard Operating Conditions (unless otherwise specified):</b> Commercial (C): $0^{\circ}\text{C} \leq T_A \leq +70^{\circ}\text{C}$ Industrial (I): $-40^{\circ}\text{C} \leq T_A \leq +85^{\circ}\text{C}$			
Symbol	Parameters	Min	Typ	Max	Units
TWR	Write command activation time	20	—	1000	$\mu\text{s}$
TACK	EEPROM write acknowledge time	—	—	10	ms
TRESP	Microcontroller acknowledge response time	20	—	1000	$\mu\text{s}$
TACK2	Decoder response acknowledge time	—	—	10	$\mu\text{s}$

\* These parameters are characterized but not tested.

## 9.1.4 ACTIVATE LEARN COMMAND IN MICRO MODE

		<b>Standard Operating Conditions (unless otherwise specified):</b> Commercial (C): $0^{\circ}\text{C} \leq T_A \leq +70^{\circ}\text{C}$ Industrial (I): $-40^{\circ}\text{C} \leq T_A \leq +85^{\circ}\text{C}$			
<b>Symbol</b>	<b>Parameters</b>	<b>Min</b>	<b>Typ</b>	<b>Max</b>	<b>Units</b>
TLRN	Learn command activation time	20	—	1000	$\mu\text{s}$
TACK	Decoder acknowledge time	—	—	20	$\mu\text{s}$
TRESP	Microcontroller acknowledge response time	20	—	1000	$\mu\text{s}$
TACK2	Decoder data line low	—	—	10	$\mu\text{s}$

\* These parameters are characterized but not tested.

## 9.1.5 ACTIVATE LEARN COMMAND IN STAND-ALONE MODE

		<b>Standard Operating Conditions (unless otherwise specified):</b> Commercial (C): $0^{\circ}\text{C} \leq T_A \leq +70^{\circ}\text{C}$ Industrial (I): $-40^{\circ}\text{C} \leq T_A \leq +85^{\circ}\text{C}$			
<b>Symbol</b>	<b>Parameters</b>	<b>Min</b>	<b>Typ</b>	<b>Max</b>	<b>Units</b>
TPP1	Command request time	—	—	100	ms
TPP2	Learn command activation time	—	—	2	s
TPP3	Erase-all command activation time	—	—	6	s

\* These parameters are characterized but not tested.

## 9.1.6 LEARN STATUS STRING

		<b>Standard Operating Conditions (unless otherwise specified):</b> Commercial (C): $0^{\circ}\text{C} \leq T_A \leq +70^{\circ}\text{C}$ Industrial (I): $-40^{\circ}\text{C} \leq T_A \leq +85^{\circ}\text{C}$			
<b>Symbol</b>	<b>Parameters</b>	<b>Min</b>	<b>Typ</b>	<b>Max</b>	<b>Units</b>
TDHI	Command request time	—	—	500	ms
TCLA	Microcontroller command request time	0.005	—	500	ms
TCA	Decoder request acknowledge time	—	—	10	$\mu\text{s}$
TCLH	Clock high hold time	—	—	1.2	ms
TCLL	Clock low hold time	0.020	—	1.2	ms
TCLKH	Clock high time	20	—	1000	$\mu\text{s}$
TCLKL	Clock low time	20	—	1000	$\mu\text{s}$
FCLK	Clock frequency	500	—	25000	Hz
TDS	Data hold time	—	—	5	$\mu\text{s}$

\* These parameters are characterized but not tested.

# HCS500

## 9.1.7 ERASE ALL COMMAND

		<b>Standard Operating Conditions (unless otherwise specified):</b> Commercial (C): 0°C ≤TA ≤+70°C Industrial (I): -40°C ≤TA ≤+85°C			
<b>Symbol</b>	<b>Parameters</b>	<b>Min</b>	<b>Typ</b>	<b>Max</b>	<b>Units</b>
TERA	Learn command activation time	20	—	1000	μs
TACK	Decoder acknowledge time	20	—	210	ms
TRESP	Microcontroller acknowledge response time	20	—	1000	μs
TACK2	Decoder data line low	—	—	10	μs

\* These parameters are characterized but not tested.

## 9.1.8 PROGRAMMING COMMAND

		<b>Standard Operating Conditions (unless otherwise specified):</b> Commercial (C): 0°C ≤TA ≤+70°C Industrial (I): -40°C ≤TA ≤+85°C			
<b>Symbol</b>	<b>Parameters</b>	<b>Min</b>	<b>Typ</b>	<b>Max</b>	<b>Units</b>
TPP1	Command request time	—	—	500	ms
TPP2	Decoder acknowledge time	—	—	1	ms
TPP3	Start Command mode to first command bit	20	—	1000	μs
TPP4	Data line low before tri-stated	—	—	5	μs
TCLKH	Clock high time	20	—	1000	μs
TCLKL	Clock low time	20	—	1000	μs
FCLK	Clock frequency	500	—	25000	Hz
TDS	Data hold time	—	—	5	μs
TCMD	Command validate time	—	—	10	μs
TACK	Command acknowledge time	30	—	240	ms
TWT2	Acknowledge respond time	20	—	1000	μs
TALW	Data low after clock low	—	—	10	μs

\* These parameters are characterized but not tested.

**FIGURE 9-2: TYPICAL MICROCONTROLLER INTERFACE CIRCUIT**

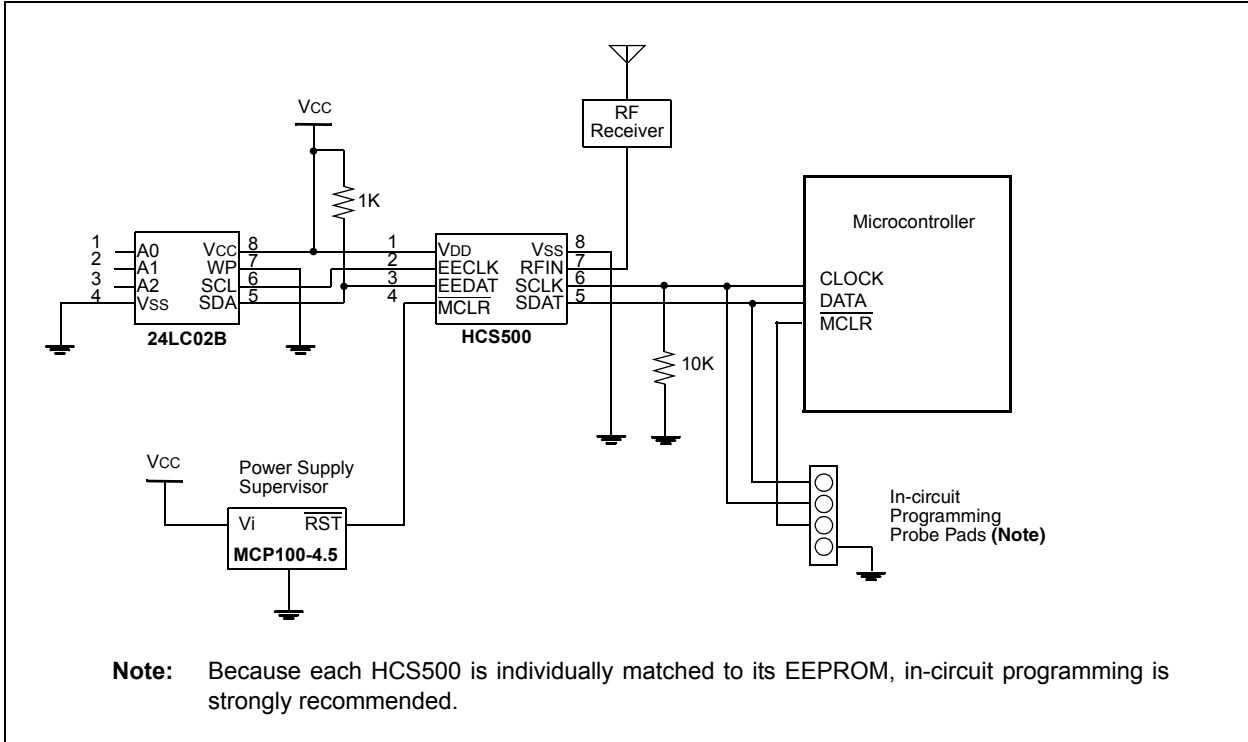

# HCS500

---

## 10.0 PACKAGING INFORMATION

### 10.1 Package Marking Information

8-Lead PDIP



Example



8-Lead SOIC



Example



<b>Legend:</b>	XX...X	Customer specific information*
	Y	Year code (last digit of calendar year)
	YY	Year code (last 2 digits of calendar year)
	WW	Week code (week of January 1 is week '01')
	NNN	Alphanumeric traceability code

<b>Note:</b>	In the event the full Microchip part number cannot be marked on one line, it will be carried over to the next line thus limiting the number of available characters for customer specific information.
--------------	--

\* Standard PIC MCU device marking consists of Microchip part number, year code, week code, and traceability code. For PIC MCU device marking beyond this, certain price adders apply. Please check with your Microchip Sales Office. For QTP devices, any special marking adders are included in QTP price.

## 10.2 Package Details

### 8-Lead Plastic Dual In-Line (P) – 300 mil Body [PDIP]

**Note:** For the most current package drawings, please see the Microchip Packaging Specification located at <http://www.microchip.com/packaging>

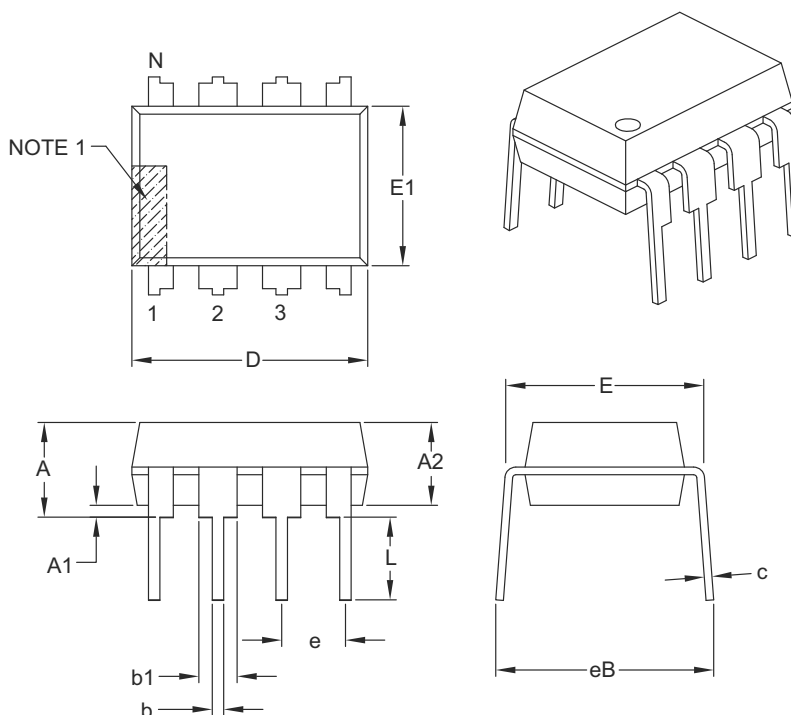

Dimension Limits	Units	INCHES		
		MIN	NOM	MAX
Number of Pins	N	8		
Pitch	e	.100 BSC		
Top to Seating Plane	A	–	–	.210
Molded Package Thickness	A2	.115	.130	.195
Base to Seating Plane	A1	.015	–	–
Shoulder to Shoulder Width	E	.290	.310	.325
Molded Package Width	E1	.240	.250	.280
Overall Length	D	.348	.365	.400
Tip to Seating Plane	L	.115	.130	.150
Lead Thickness	c	.008	.010	.015
Upper Lead Width	b1	.040	.060	.070
Lower Lead Width	b	.014	.018	.022
Overall Row Spacing §	eB	–	–	.430

**Notes:**

1. Pin 1 visual index feature may vary, but must be located with the hatched area.
2. § Significant Characteristic.
3. Dimensions D and E1 do not include mold flash or protrusions. Mold flash or protrusions shall not exceed .010" per side.
4. Dimensioning and tolerancing per ASME Y14.5M.

BSC: Basic Dimension. Theoretically exact value shown without tolerances.

Microchip Technology Drawing C04-018B

# HCS500

## 8-Lead Plastic Small Outline (SN) - Narrow, 3.90 mm Body [SOIC]

**Note:** For the most current package drawings, please see the Microchip Packaging Specification located at <http://www.microchip.com/packaging>

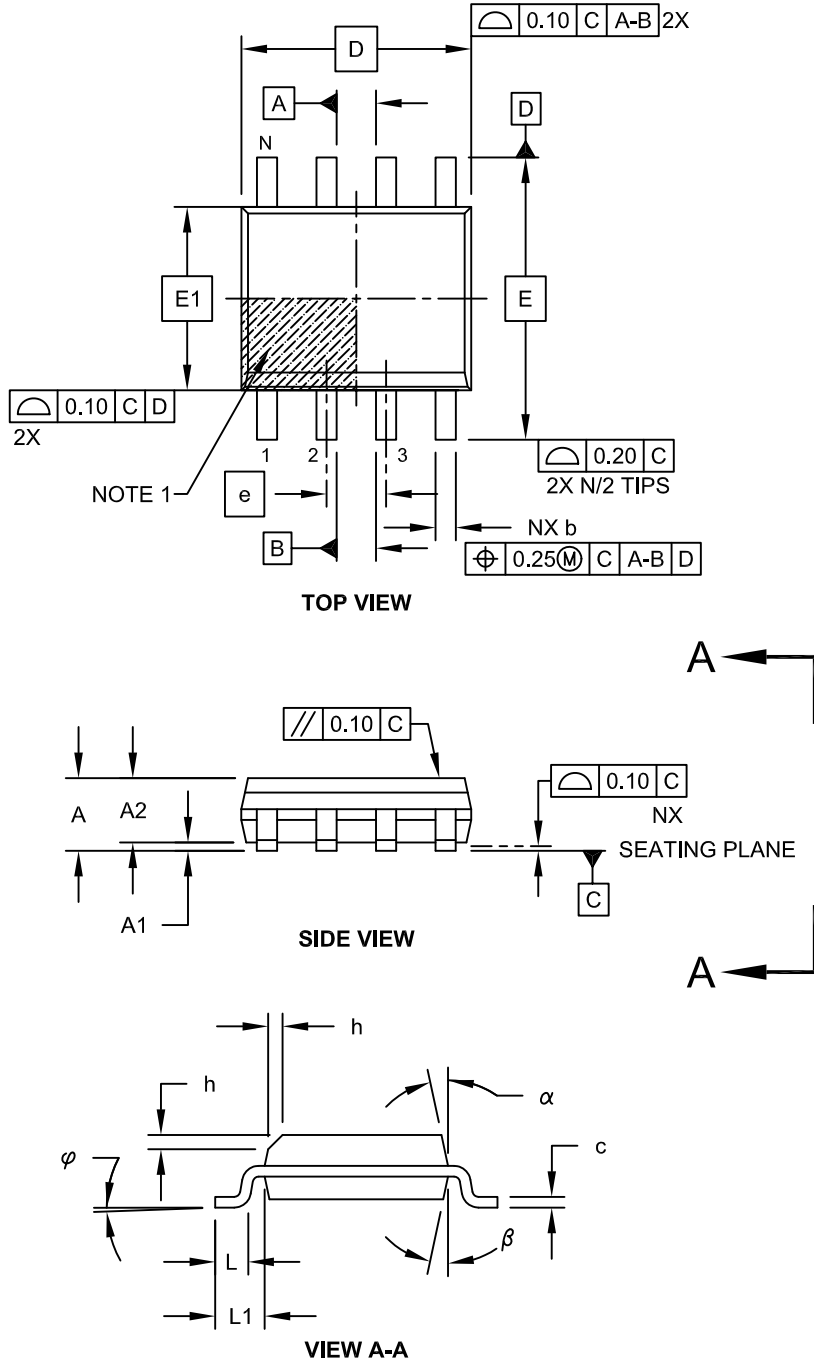

Microchip Technology Drawing No. C04-057C Sheet 1 of 2



## 8-Lead Plastic Small Outline (SN) - Narrow, 3.90 mm Body [SOIC]

**Note:** For the most current package drawings, please see the Microchip Packaging Specification located at <http://www.microchip.com/packaging>

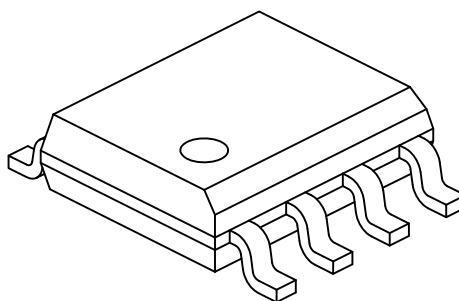

Dimension Limits	Units	MILLIMETERS		
		MIN	NOM	MAX
Number of Pins	N	8		
Pitch	e	1.27 BSC		
Overall Height	A	-	-	1.75
Molded Package Thickness	A2	1.25	-	-
Standoff §	A1	0.10	-	0.25
Overall Width	E	6.00 BSC		
Molded Package Width	E1	3.90 BSC		
Overall Length	D	4.90 BSC		
Chamfer (Optional)	h	0.25	-	0.50
Foot Length	L	0.40	-	1.27
Footprint	L1	1.04 REF		
Foot Angle	φ	0°	-	8°
Lead Thickness	c	0.17	-	0.25
Lead Width	b	0.31	-	0.51
Mold Draft Angle Top	α	5°	-	15°
Mold Draft Angle Bottom	β	5°	-	15°

**Notes:**

1. Pin 1 visual index feature may vary, but must be located within the hatched area.
2. § Significant Characteristic
3. Dimensions D and E1 do not include mold flash or protrusions. Mold flash or protrusions shall not exceed 0.15mm per side.
4. Dimensioning and tolerancing per ASME Y14.5M

BSC: Basic Dimension. Theoretically exact value shown without tolerances.

REF: Reference Dimension, usually without tolerance, for information purposes only.

Microchip Technology Drawing No. C04-057C Sheet 2 of 2

# HCS500

## 8-Lead Plastic Small Outline (SN) – Narrow, 3.90 mm Body [SOIC]

**Note:** For the most current package drawings, please see the Microchip Packaging Specification located at <http://www.microchip.com/packaging>

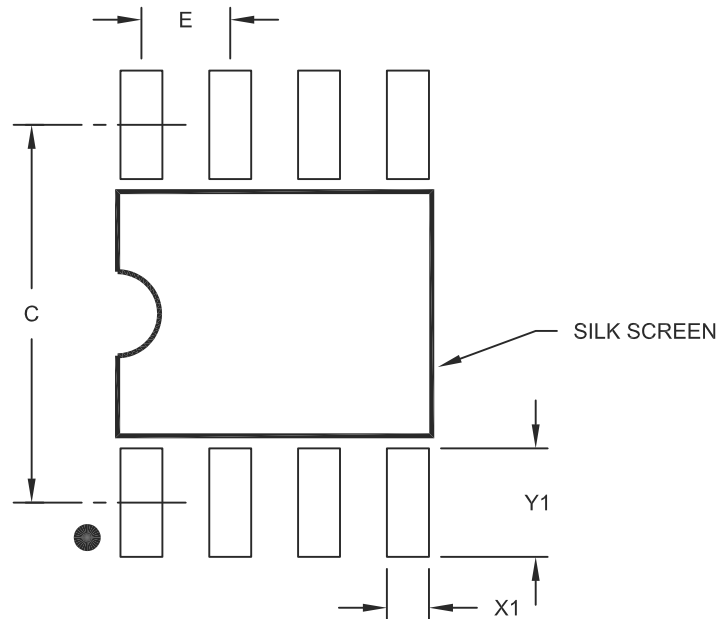

RECOMMENDED LAND PATTERN

Dimension Limits	Units	MILLIMETERS		
		MIN	NOM	MAX
Contact Pitch	E	1.27 BSC		
Contact Pad Spacing	C		5.40	
Contact Pad Width (X8)	X1			0.60
Contact Pad Length (X8)	Y1			1.55

Notes:

1. Dimensioning and tolerancing per ASME Y14.5M

BSC: Basic Dimension. Theoretically exact value shown without tolerances.

Microchip Technology Drawing No. C04-2057A

## APPENDIX A: ADDITIONAL INFORMATION

Microchip's Secure Data Products are covered by some or all of the following:

Code hopping encoder patents issued in European countries and U.S.A.

Secure learning patents issued in European countries, U.S.A. and R.S.A.

## REVISION HISTORY

### Revision D (June 2011)

- Updated the following sections: Development Support, The Microchip Web Site, Reader Response and HCS500 Product Identification System
- Added new section **Appendix A**
- Minor formatting and text changes were incorporated throughout the document

## THE MICROCHIP WEB SITE

Microchip provides online support via our WWW site at [www.microchip.com](http://www.microchip.com). This web site is used as a means to make files and information easily available to customers. Accessible by using your favorite Internet browser, the web site contains the following information:

- **Product Support** – Data sheets and errata, application notes and sample programs, design resources, user's guides and hardware support documents, latest software releases and archived software
- **General Technical Support** – Frequently Asked Questions (FAQ), technical support requests, online discussion groups, Microchip consultant program member listing
- **Business of Microchip** – Product selector and ordering guides, latest Microchip press releases, listing of seminars and events, listings of Microchip sales offices, distributors and factory representatives

## CUSTOMER CHANGE NOTIFICATION SERVICE

Microchip's customer notification service helps keep customers current on Microchip products. Subscribers will receive e-mail notification whenever there are changes, updates, revisions or errata related to a specified product family or development tool of interest.

To register, access the Microchip web site at [www.microchip.com](http://www.microchip.com). Under "Support", click on "Customer Change Notification" and follow the registration instructions.

## CUSTOMER SUPPORT

Users of Microchip products can receive assistance through several channels:

- Distributor or Representative
- Local Sales Office
- Field Application Engineer (FAE)
- Technical Support
- Development Systems Information Line

Customers should contact their distributor, representative or field application engineer (FAE) for support. Local sales offices are also available to help customers. A listing of sales offices and locations is included in the back of this document.

**Technical support is available through the web site at: <http://microchip.com/support>**

## READER RESPONSE

It is our intention to provide you with the best documentation possible to ensure successful use of your Microchip product. If you wish to provide your comments on organization, clarity, subject matter, and ways in which our documentation can better serve you, please FAX your comments to the Technical Publications Manager at (480) 792-4150.

Please list the following information, and use this outline to provide us with your comments about this document.

TO: Technical Publications Manager Total Pages Sent \_\_\_\_\_

RE: Reader Response

From: Name \_\_\_\_\_

Company \_\_\_\_\_

Address \_\_\_\_\_

City / State / ZIP / Country \_\_\_\_\_

Telephone: (\_\_\_\_\_) \_\_\_\_\_ - \_\_\_\_\_ FAX: (\_\_\_\_\_) \_\_\_\_\_ - \_\_\_\_\_

Application (optional):

Would you like a reply?  Y  N

Device: HCS500

Literature Number: DS40153D

Questions:

1. What are the best features of this document?

---

---

2. How does this document meet your hardware and software development needs?

---

---

3. Do you find the organization of this document easy to follow? If not, why?

---

---

4. What additions to the document do you think would enhance the structure and subject?

---

---

5. What deletions from the document could be made without affecting the overall usefulness?

---

---

6. Is there any incorrect or misleading information (what and where)?

---

---

7. How would you improve this document?

---

---

# HCS500

---

---

## HCS500 PRODUCT IDENTIFICATION SYSTEM

To order or obtain information, e.g., on pricing or delivery, refer to the factory or the listed sales office.

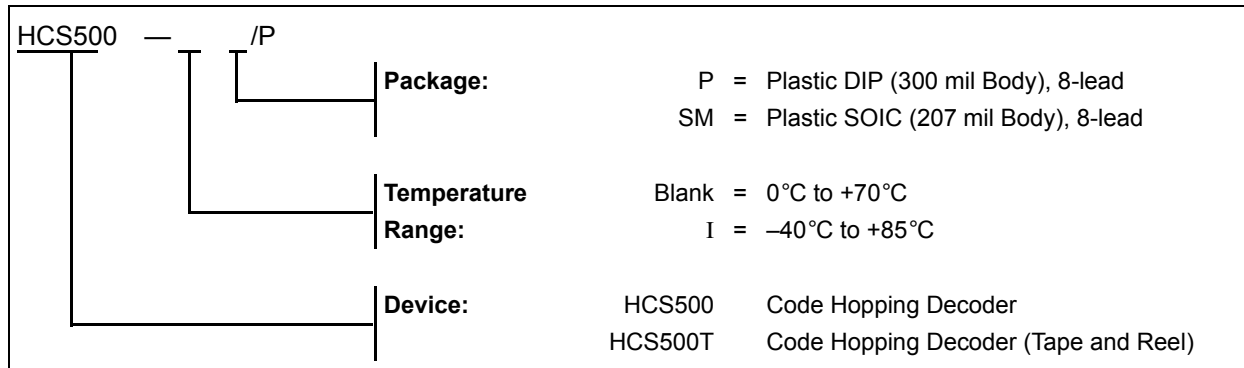

---

**Note the following details of the code protection feature on Microchip devices:**

- Microchip products meet the specification contained in their particular Microchip Data Sheet.
- Microchip believes that its family of products is one of the most secure families of its kind on the market today, when used in the intended manner and under normal conditions.
- There are dishonest and possibly illegal methods used to breach the code protection feature. All of these methods, to our knowledge, require using the Microchip products in a manner outside the operating specifications contained in Microchip's Data Sheets. Most likely, the person doing so is engaged in theft of intellectual property.
- Microchip is willing to work with the customer who is concerned about the integrity of their code.
- Neither Microchip nor any other semiconductor manufacturer can guarantee the security of their code. Code protection does not mean that we are guaranteeing the product as “unbreakable.”

Code protection is constantly evolving. We at Microchip are committed to continuously improving the code protection features of our products. Attempts to break Microchip's code protection feature may be a violation of the Digital Millennium Copyright Act. If such acts allow unauthorized access to your software or other copyrighted work, you may have a right to sue for relief under that Act.

---

Information contained in this publication regarding device applications and the like is provided only for your convenience and may be superseded by updates. It is your responsibility to ensure that your application meets with your specifications. MICROCHIP MAKES NO REPRESENTATIONS OR WARRANTIES OF ANY KIND WHETHER EXPRESS OR IMPLIED, WRITTEN OR ORAL, STATUTORY OR OTHERWISE, RELATED TO THE INFORMATION, INCLUDING BUT NOT LIMITED TO ITS CONDITION, QUALITY, PERFORMANCE, MERCHANTABILITY OR FITNESS FOR PURPOSE. Microchip disclaims all liability arising from this information and its use. Use of Microchip devices in life support and/or safety applications is entirely at the buyer's risk, and the buyer agrees to defend, indemnify and hold harmless Microchip from any and all damages, claims, suits, or expenses resulting from such use. No licenses are conveyed, implicitly or otherwise, under any Microchip intellectual property rights.

**Trademarks**

The Microchip name and logo, the Microchip logo, dsPIC, KEELOQ, KEELOQ logo, MPLAB, PIC, PICmicro, PICSTART, PIC<sup>32</sup> logo, rPIC and UNI/O are registered trademarks of Microchip Technology Incorporated in the U.S.A. and other countries.

FilterLab, Hampshire, HI-TECH C, Linear Active Thermistor, MXDEV, MXLAB, SEEVAL and The Embedded Control Solutions Company are registered trademarks of Microchip Technology Incorporated in the U.S.A.

Analog-for-the-Digital Age, Application Maestro, CodeGuard, dsPICDEM, dsPICDEM.net, dsPICworks, dsSPEAK, ECAN, ECONOMONITOR, FanSense, HI-TIDE, In-Circuit Serial Programming, ICSP, Mindi, MiWi, MPASM, MPLAB Certified logo, MPLIB, MPLINK, mTouch, Omniscient Code Generation, PICC, PICC-18, PICDEM, PICDEM.net, PICkit, PICTail, REAL ICE, rLAB, Select Mode, Total Endurance, TSHARC, UniWinDriver, WiperLock and ZENA are trademarks of Microchip Technology Incorporated in the U.S.A. and other countries.

SQTP is a service mark of Microchip Technology Incorporated in the U.S.A.

All other trademarks mentioned herein are property of their respective companies.

© 2011, Microchip Technology Incorporated, Printed in the U.S.A., All Rights Reserved.

 Printed on recycled paper.

ISBN: 978-1-61341-225-1

*Microchip received ISO/TS-16949:2002 certification for its worldwide headquarters, design and wafer fabrication facilities in Chandler and Tempe, Arizona; Gresham, Oregon and design centers in California and India. The Company's quality system processes and procedures are for its PIC® MCUs and dsPIC® DSCs, KEELOQ® code hopping devices, Serial EEPROMs, microperipherals, nonvolatile memory and analog products. In addition, Microchip's quality system for the design and manufacture of development systems is ISO 9001:2000 certified.*

**QUALITY MANAGEMENT SYSTEM  
CERTIFIED BY DNV  
== ISO/TS 16949:2002 ==**



# MICROCHIP

## Worldwide Sales and Service

### AMERICAS

**Corporate Office**  
2355 West Chandler Blvd.  
Chandler, AZ 85224-6199  
Tel: 480-792-7200  
Fax: 480-792-7277  
Technical Support:  
<http://www.microchip.com/support>  
Web Address:  
[www.microchip.com](http://www.microchip.com)

**Atlanta**  
Duluth, GA  
Tel: 678-957-9614  
Fax: 678-957-1455

**Boston**  
Westborough, MA  
Tel: 774-760-0087  
Fax: 774-760-0088

**Chicago**  
Itasca, IL  
Tel: 630-285-0071  
Fax: 630-285-0075

**Cleveland**  
Independence, OH  
Tel: 216-447-0464  
Fax: 216-447-0643

**Dallas**  
Addison, TX  
Tel: 972-818-7423  
Fax: 972-818-2924

**Detroit**  
Farmington Hills, MI  
Tel: 248-538-2250  
Fax: 248-538-2260

**Indianapolis**  
Noblesville, IN  
Tel: 317-773-8323  
Fax: 317-773-5453

**Los Angeles**  
Mission Viejo, CA  
Tel: 949-462-9523  
Fax: 949-462-9608

**Santa Clara**  
Santa Clara, CA  
Tel: 408-961-6444  
Fax: 408-961-6445

**Toronto**  
Mississauga, Ontario,  
Canada  
Tel: 905-673-0699  
Fax: 905-673-6509

### ASIA/PACIFIC

**Asia Pacific Office**  
Suites 3707-14, 37th Floor  
Tower 6, The Gateway  
Harbour City, Kowloon  
Hong Kong  
Tel: 852-2401-1200  
Fax: 852-2401-3431

**Australia - Sydney**  
Tel: 61-2-9868-6733  
Fax: 61-2-9868-6755

**China - Beijing**  
Tel: 86-10-8569-7000  
Fax: 86-10-8528-2104

**China - Chengdu**  
Tel: 86-28-8665-5511  
Fax: 86-28-8665-7889

**China - Chongqing**  
Tel: 86-23-8980-9588  
Fax: 86-23-8980-9500

**China - Hangzhou**  
Tel: 86-571-2819-3180  
Fax: 86-571-2819-3189

**China - Hong Kong SAR**  
Tel: 852-2401-1200  
Fax: 852-2401-3431

**China - Nanjing**  
Tel: 86-25-8473-2460  
Fax: 86-25-8473-2470

**China - Qingdao**  
Tel: 86-532-8502-7355  
Fax: 86-532-8502-7205

**China - Shanghai**  
Tel: 86-21-5407-5533  
Fax: 86-21-5407-5066

**China - Shenyang**  
Tel: 86-24-2334-2829  
Fax: 86-24-2334-2393

**China - Shenzhen**  
Tel: 86-755-8203-2660  
Fax: 86-755-8203-1760

**China - Wuhan**  
Tel: 86-27-5980-5300  
Fax: 86-27-5980-5118

**China - Xian**  
Tel: 86-29-8833-7252  
Fax: 86-29-8833-7256

**China - Xiamen**  
Tel: 86-592-2388138  
Fax: 86-592-2388130

**China - Zhuhai**  
Tel: 86-756-3210040  
Fax: 86-756-3210049

### ASIA/PACIFIC

**India - Bangalore**  
Tel: 91-80-3090-4444  
Fax: 91-80-3090-4123

**India - New Delhi**  
Tel: 91-11-4160-8631  
Fax: 91-11-4160-8632

**India - Pune**  
Tel: 91-20-2566-1512  
Fax: 91-20-2566-1513

**Japan - Yokohama**  
Tel: 81-45-471- 6166  
Fax: 81-45-471-6122

**Korea - Daegu**  
Tel: 82-53-744-4301  
Fax: 82-53-744-4302

**Korea - Seoul**  
Tel: 82-2-554-7200  
Fax: 82-2-558-5932 or  
82-2-558-5934

**Malaysia - Kuala Lumpur**  
Tel: 60-3-6201-9857  
Fax: 60-3-6201-9859

**Malaysia - Penang**  
Tel: 60-4-227-8870  
Fax: 60-4-227-4068

**Philippines - Manila**  
Tel: 63-2-634-9065  
Fax: 63-2-634-9069

**Singapore**  
Tel: 65-6334-8870  
Fax: 65-6334-8850

**Taiwan - Hsin Chu**  
Tel: 886-3-6578-300  
Fax: 886-3-6578-370

**Taiwan - Kaohsiung**  
Tel: 886-7-213-7830  
Fax: 886-7-330-9305

**Taiwan - Taipei**  
Tel: 886-2-2500-6610  
Fax: 886-2-2508-0102

**Thailand - Bangkok**  
Tel: 66-2-694-1351  
Fax: 66-2-694-1350

### EUROPE

**Austria - Wels**  
Tel: 43-7242-2244-39  
Fax: 43-7242-2244-393

**Denmark - Copenhagen**  
Tel: 45-4450-2828  
Fax: 45-4485-2829

**France - Paris**  
Tel: 33-1-69-53-63-20  
Fax: 33-1-69-30-90-79

**Germany - Munich**  
Tel: 49-89-627-144-0  
Fax: 49-89-627-144-44

**Italy - Milan**  
Tel: 39-0331-742611  
Fax: 39-0331-466781

**Netherlands - Drunen**  
Tel: 31-416-690399  
Fax: 31-416-690340

**Spain - Madrid**  
Tel: 34-91-708-08-90  
Fax: 34-91-708-08-91

**UK - Wokingham**  
Tel: 44-118-921-5869  
Fax: 44-118-921-5820

05/02/11





Компания «ЭлектроПласт» предлагает заключение долгосрочных отношений при поставках импортных электронных компонентов на взаимовыгодных условиях!

Наши преимущества:

- Оперативные поставки широкого спектра электронных компонентов отечественного и импортного производства напрямую от производителей и с крупнейших мировых складов;
- Поставка более 17-ти миллионов наименований электронных компонентов;
- Поставка сложных, дефицитных, либо снятых с производства позиций;
- Оперативные сроки поставки под заказ (от 5 рабочих дней);
- Экспресс доставка в любую точку России;
- Техническая поддержка проекта, помощь в подборе аналогов, поставка прототипов;
- Система менеджмента качества сертифицирована по Международному стандарту ISO 9001;
- Лицензия ФСБ на осуществление работ с использованием сведений, составляющих государственную тайну;
- Поставка специализированных компонентов (Xilinx, Altera, Analog Devices, Intersil, Interpoint, Microsemi, Aeroflex, Peregrine, Syfer, Eurofarad, Texas Instrument, Miteq, Cobham, E2V, MA-COM, Hittite, Mini-Circuits, General Dynamics и др.);

Помимо этого, одним из направлений компании «ЭлектроПласт» является направление «Источники питания». Мы предлагаем Вам помощь Конструкторского отдела:

- Подбор оптимального решения, техническое обоснование при выборе компонента;
- Подбор аналогов;
- Консультации по применению компонента;
- Поставка образцов и прототипов;
- Техническая поддержка проекта;
- Защита от снятия компонента с производства.



#### Как с нами связаться

**Телефон:** 8 (812) 309 58 32 (многоканальный)

**Факс:** 8 (812) 320-02-42

**Электронная почта:** [org@eplast1.ru](mailto:org@eplast1.ru)

**Адрес:** 198099, г. Санкт-Петербург, ул. Калинина, дом 2, корпус 4, литера А.