

## Specification

### Small Form Factor Pluggable

Duplex LC Receptacle – SFP

### Optical Transceivers

1000BASE-LX  
 1250Mbit/s



## Ordering Information

**TSD-SxCA1-G11**

Voltage / Temperature

1. 3.3V / +0°C ~ +70°C
2. 3.3V / -40°C ~ +85°C

Model Name	Voltage	Category	Device type	Interface	SD/LOS	Temperature	Distance	Latch Color
TSD-S1CA1-G11	3.3V	With DDMI	FP / PIN	AC / AC Coupling	LVTTTL	+0°C ~+70°C	20km	Blue
TSD-S2CA1-G11						-40°C ~+85°C		

## Features

- ROHS Compliant
- Standard Small Form Factor Pluggable Package – SFP MSA Compliant
- Digital Diagnostic SFF-8472 Rev.10.2 Compliant
- Gigabit Ethernet Standard ( IEEE802.3Z 1000BASE-LX ) Compliant
- Fibre Channel Standard ( 100-SM-LC-L ) Compliant
- Laser Class 1 Product –IEC/EN 60825-1 Compliant
- Standard Duplex LC Receptacle Optical Interface
- Single + 3.3 V Power Supply
- Differential LVPECL Data Input and Output
- LVTTTL Loss of Signal
- Serial ID through I<sup>2</sup>C Interface
- Low Power Consumption

## Absolute Maximum Ratings

Parameter	Symbol	Min	Typ	Max	Unit
Storage temperature	T <sub>S</sub>	-40	--	85	°C
Supply voltage	V <sub>CC</sub>	0	--	4	V
Operating Relative Humidity	--	5	--	95	%
Input voltage	V <sub>IN</sub>	0	--	V <sub>CC</sub>	V

## Operating Conditions

Parameter	Symbol	Min	Typ	Max	Unit
Supply Voltage	V <sub>CC</sub>	3.1	3.3	3.5	V
Operating Case temperature ( TSD-S1CA1-G11 )	Top	0	--	70	°C
Operating Case temperature ( TSD-S2CA1-G11 )		-40	--	85	
Total Current ( Transmitter + Receiver )	I <sub>CC</sub>	--	--	250	mA

**Transmitter Specifications** (  $V_{CC}=3.1V\sim 3.5V$  ;  $T_{op}=0^{\circ}C\sim 70^{\circ}C$  /  $T_{op}=-40^{\circ}C\sim 85^{\circ}C$  )

Parameter	Symbol	Min	Typ	Max	Unit
<b>Optical Characteristics</b>					
Output Optical Power	$P_o$	-5	--	0	dBm
Extinction Ratio	ER	9	--	--	dB
Center Wavelength	$\lambda$	1270	1310	1355	nm
Spectral Width (RMS)	$\sigma\lambda$	--	--	4	nm
Rise/Fall time (20-80%)	$T_{r,f}$	--	--	260	ps
Relative Intensity Noise	RIN	--	--	-120	dB/Hz
Output Eye	Compliant with IEEE 802.3z				
Max. $P_{out}$ TX-DISABLE Asserted	$P_{OFF}$	--	--	-45	dBm
<b>Electrical Characteristics</b>					
Differential Input Voltage	$V_{DIFF}$	0.4	--	2.0	V
Tx_Disable_Input_High	$V_{DISH}$	2.0	--	$V_{CC}+0.3$	V
Tx_Disable_Input_Low	$V_{DISL}$	0	--	0.8	V
Tx_Fault_Output_High	$V_{FH}$	2.0	--	$V_{CC}+0.3$	V
Tx_Fault_Output_Low	$V_{FL}$	0	--	0.8	V

**Receiver Specifications** (  $V_{CC}=3.1V\sim 3.5V$  ;  $T_{op}=0^{\circ}C\sim 70^{\circ}C$  /  $T_{op}=-40^{\circ}C\sim 85^{\circ}C$  )

Parameter	Symbol	Min	Typ	Max	Unit
<b>Optical Characteristics</b>					
Optical Input Power-maximum	$P_{SATIN}$	-3	--	--	dBm
Receiver Sensitivity ( PRBS= $2^7-1$ ; BER $\leq 10^{-12}$ )	$P_{SEN}$	--	--	-23	dBm
Operating Center Wavelength	$\lambda$	1260	--	1610	nm
Optical Return Loss	ORL	12	--	--	dB
Loss of Signal – De-asserted	$P_{LD}$	--	--	-23	dBm
Loss of Signal - Asserted	$P_{LA}$	-45	--	--	dBm
Loss of Signal - Hysteresis	$P_{LH}$	0.5	--	6	dB
<b>Electrical Characteristics</b>					
Differential Output Voltage	$V_{DIFF}$	0.4	--	2.0	V
Receiver Loss of Signal Output Voltage -Low	$V_{LOSL}$	0	--	0.8	V
Receiver Loss of Signal Output Voltage -High	$V_{LOSH}$	2	--	$V_{CC}+0.3$	V

**Pin Definition and Descriptions**

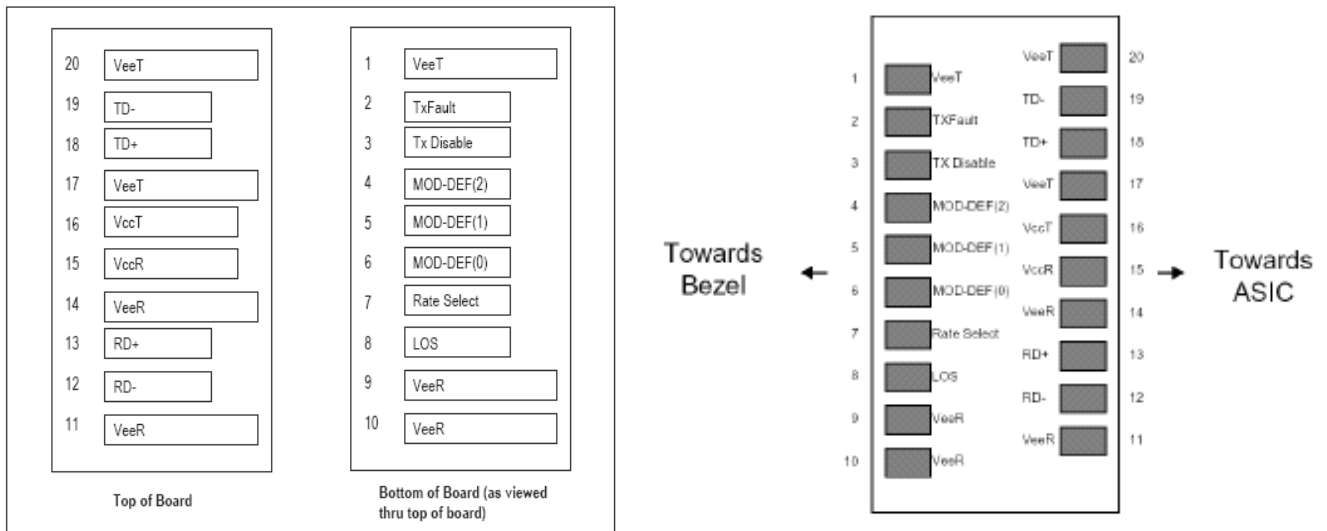

Pin	Name	Input/Output Level	Description
1	VeeT	Input	Transmitter ground
2	TXFault	Output/LVTTL	Laser failure indication. High level indicates "laser failure". Externally pulled up
3	TXDisable	Input/LVTTL	Transmitter disable, High signal/open disables TX laser output. Low level enables TX output, internally pulled up.
4	MOD-DEF(2)	Input/output	Module definition 2, SDA, Data line for I2C bus. Externally pulled up
5	MOD-DEF(1)	Input	Module definition 1, SCL, Clock for I2C bus. Externally pulled up
6	MOD-DEF(0)	Output	Module definition 0, Module present. Ground inside module.
7	Rate Select	-	No connection.
8	LOS	Output/LVTTL	Receiver loss of signal indication. Low signal indicates optical signal is present at RX input. Should be Externally pulled up.
9	VeeR	Input	Receiver ground
10	VeeR	Input	Receiver ground
11	VeeR	Input	Receiver ground
12	RD -	Output/CML	Inverted receiver data output (AC coupled)
13	RD +	Output/CML	Non-inverted receiver data output (AC coupled)
14	VeeR	Input	Receiver ground
15	VccR	Input	Receiver power supply
16	VccT	Input	Transmitter power supply
17	VeeT	Input	Transmitter ground
18	TD +	Input/LVPECL	Non-inverted transmitter data input (AC coupled)
19	TD -	Input/LVPECL	Inverted transmitter data input (AC coupled)
20	VeeT	Input	Transmitter ground

Recommended Circuit Diagram

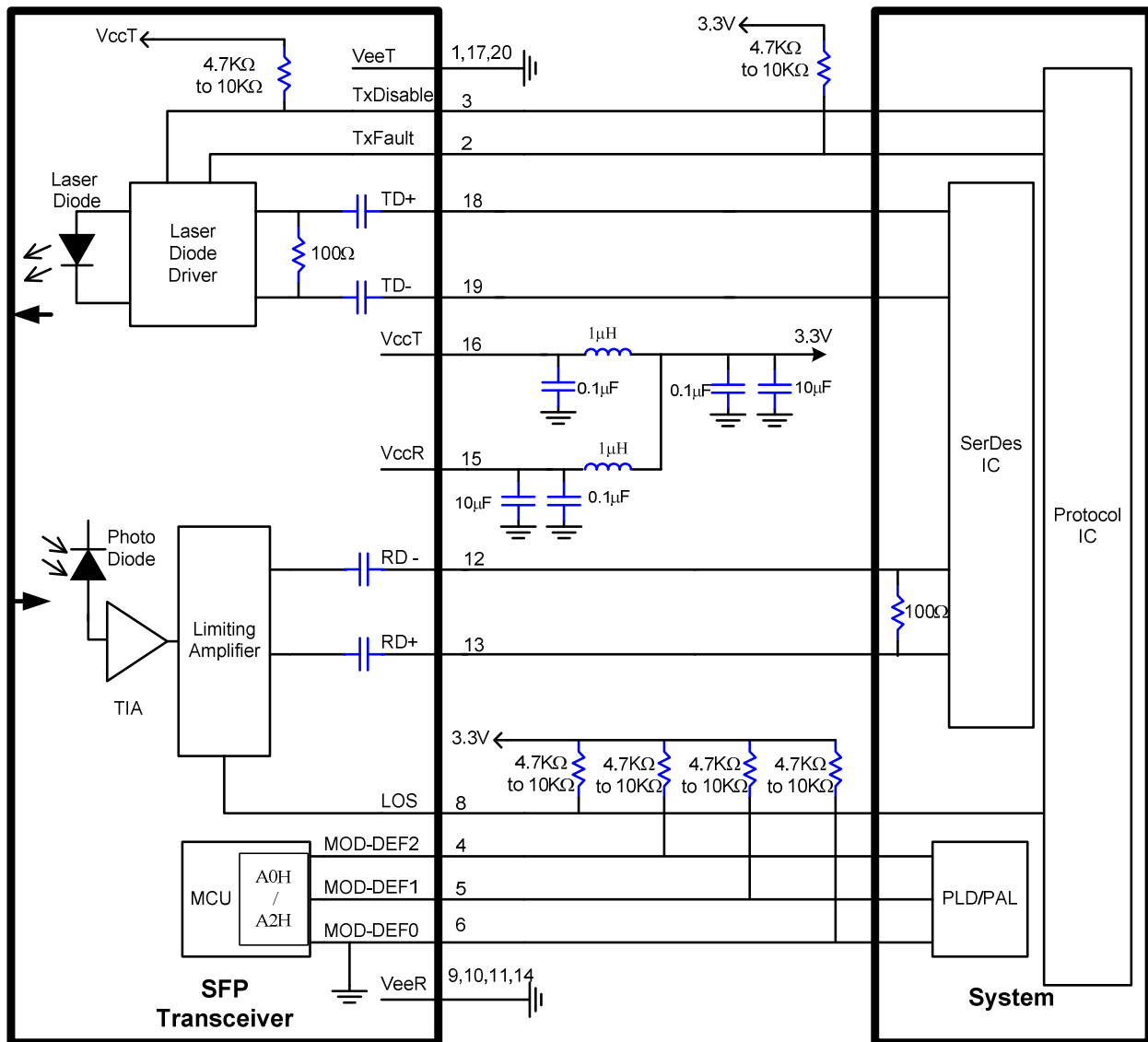

## Mechanical Outlines

( Unit : mm )

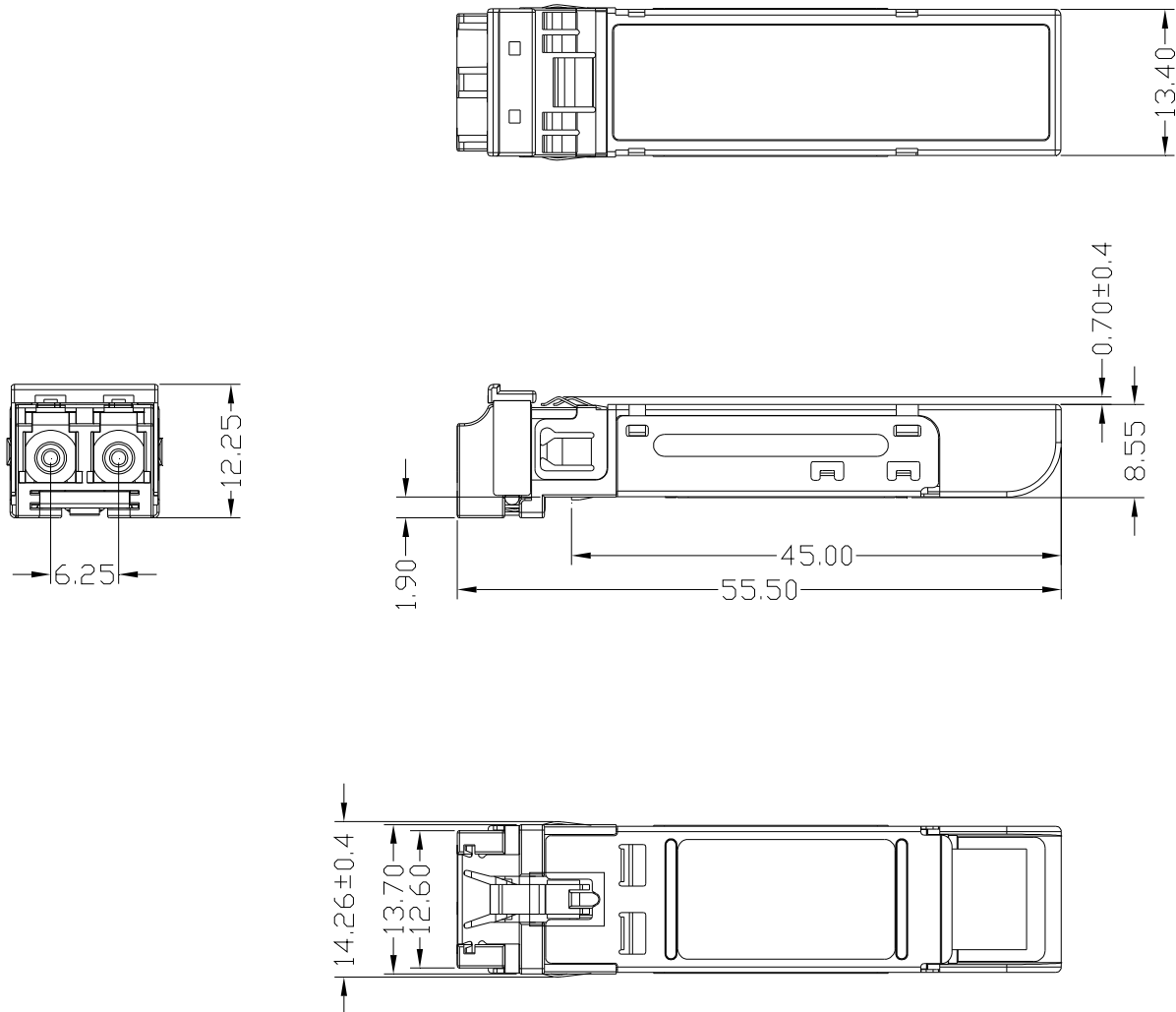

## ESD

Normal ESD precautions are required during the handling of this module. This transceiver is shipped in ESD protective packaging. It should be removed from the packaging and handled only in an ESD protected environment.



## Contact Information

**Formerica OptoElectronics Inc.**

5F-11, No.38, Taiyuan St., Zhubei City,  
Hsinchu County 30265, Taiwan

Tel: +886-3-5600286

Fax: +886-3-5600239

**San Diego, CA**

Tel: 1-949-466-8069

[inquiry@formericaoe.com](mailto:inquiry@formericaoe.com)

[www.formericaoe.com](http://www.formericaoe.com)





Компания «ЭлектроПласт» предлагает заключение долгосрочных отношений при поставках импортных электронных компонентов на взаимовыгодных условиях!

Наши преимущества:

- Оперативные поставки широкого спектра электронных компонентов отечественного и импортного производства напрямую от производителей и с крупнейших мировых складов;
- Поставка более 17-ти миллионов наименований электронных компонентов;
- Поставка сложных, дефицитных, либо снятых с производства позиций;
- Оперативные сроки поставки под заказ (от 5 рабочих дней);
- Экспресс доставка в любую точку России;
- Техническая поддержка проекта, помощь в подборе аналогов, поставка прототипов;
- Система менеджмента качества сертифицирована по Международному стандарту ISO 9001;
- Лицензия ФСБ на осуществление работ с использованием сведений, составляющих государственную тайну;
- Поставка специализированных компонентов (Xilinx, Altera, Analog Devices, Intersil, Interpoint, Microsemi, Aeroflex, Peregrine, Syfer, Eurofarad, Texas Instrument, Miteq, Cobham, E2V, MA-COM, Hittite, Mini-Circuits, General Dynamics и др.);

Помимо этого, одним из направлений компании «ЭлектроПласт» является направление «Источники питания». Мы предлагаем Вам помощь Конструкторского отдела:

- Подбор оптимального решения, техническое обоснование при выборе компонента;
- Подбор аналогов;
- Консультации по применению компонента;
- Поставка образцов и прототипов;
- Техническая поддержка проекта;
- Защита от снятия компонента с производства.



#### Как с нами связаться

**Телефон:** 8 (812) 309 58 32 (многоканальный)

**Факс:** 8 (812) 320-02-42

**Электронная почта:** [org@eplast1.ru](mailto:org@eplast1.ru)

**Адрес:** 198099, г. Санкт-Петербург, ул. Калинина, дом 2, корпус 4, литера А.