



## SPECIFICATION FOR APPROVAL

Customer : \_\_\_\_\_  
Description : DC FAN \_\_\_\_\_  
Customer Part No. \_\_\_\_\_ REV. : \_\_\_\_\_  
Delta Model No. : PFB0948GHED6W \_\_\_\_\_ REV. : 00 \_\_\_\_\_  
Sample Issue No. : \_\_\_\_\_  
Sample Issue Date : MAY.15 2017 \_\_\_\_\_

PLEASE SEND ONE COPY OF THIS SPECIFICATION BACK AFTER YOU SIGNED APPROVAL FOR PRODUCTION PRE-ARRANGMENT.

APPROVED BY:

DATE :

DELTA ELECTRONICS, INC.  
TAOYUAN PLANT  
252, SHANGYING ROAD, GUISHAN INDUSTRIAL ZONE  
TAOYUAN CITY 33341, TAIWAN, R.O.C.  
TEL:886-(0)3-3591968  
FAX:886-(0)3-3591991



Delta Electronics, Inc.  
No.252, Shanying Rd., Guishan Industrial Zone,  
Taoyuan City 33341, Taiwan, R.O.C.

TEL : 886-(0)3-3591968  
FAX : 886-(0)3-3591991

## **STATEMENT OF DEVIATION**

NONE

DESCRIPTION:

Delta Electronics, Inc.  
 No.252, Shanying Rd., Guishan Industrial Zone,  
 Taoyuan City 33341, Taiwan, R.O.C.

TEL : 886-(0)3-3591968  
 FAX : 886-(0)3-3591991

## Specification For Approval

Customer :

Description : DC FAN

Customer P/N :

rev. :

Delta model no. : PFB0948GHEDW

Delta Safety Model No.: PFB0948GHE

Sample revision. : 00

Issue no.:

Sample issue date : MAY.15 2017

Quantity :

### 1. SCOPE:

THIS SPECIFICATION DEFINES THE ELECTRICAL AND MECHANICAL CHARACTERISTICS OF THE DC BRUSHLESS AXIAL FLOW FAN.

### 2. CHARACTERS:

ITEM	DESCRIPTION
RATED VOLTAGE	48 VDC
OPERATION VOLTAGE	36.0 - 60.0 VDC
INPUT CURRENT(AVG.)	0.35 (MAX. 0.42) A SAFETY CURRENT ON LABEL :0.42A
INPUT POWER(AVG.)	16.80 (MAX. 20.16) W
SPEED	6000 ± 10% R.P.M.
MAX. AIR FLOW (AT ZERO STATIC PRESSURE)	3.50 (MIN. 3.15) M <sup>3</sup> /MIN. 123.58(MIN. 111.22) CFM
MAX. AIR PRESSURE (AT ZERO AIRFLOW)	25.78 (MIN. 20.88) mmH <sub>2</sub> O 1.015 (MIN. 0.822) inchH <sub>2</sub> O
ACOUSTICAL NOISE (AVG.)	60.5 (MAX. 64.5) dB-A
INSULATION TYPE	UL: CLASS A
INSULATION STRENGT	10 MEG OHM MIN. AT 500 VDC (BETWEEN FRAME AND (+) TERMINAL)
DIELECTRIC STRENGTH	5 mA MAX. AT 500 VAC 50/60 Hz ONE MINUTE, (BETWEEN FRAME AND (+) TERMINAL)

(continued)

PART NO:

DELTA MODEL: PFB0948GHED6W

LIFE EXPECTANCE (L10) (AT LABEL VOLTAGE)	70,000 HOURS CONTINUOUS OPERATION AT 40 °C WITH 15 ~ 65 %RH.
ROTATION	CLOCKWISE VIEW FROM NAME PLATE SIDE
LOCKED ROTOR SHUT DOWN	THE CURRENT WILL SHUT DOWN, WHEN ROTOR LOCKED AND FIXED.

NOTES:

1. ALL READINGS ARE MEASURED AFTER STABLY WARMING UP THROUGH 10 MINUTES.
2. STANDARD AIR PROPERTY IS AIR AT (Td) 25°C TEMPERATURE, (RH) 65% RELATIVE HUMIDITY , AND (Pb) 760 mmHg BAROMETRIC PRESSURE.
3. THE VALUES WRITTEN IN PARENS , ( ), ARE LIMITED SPEC.
4. ACOUSTICAL NOISE MEASURING CONDITION:

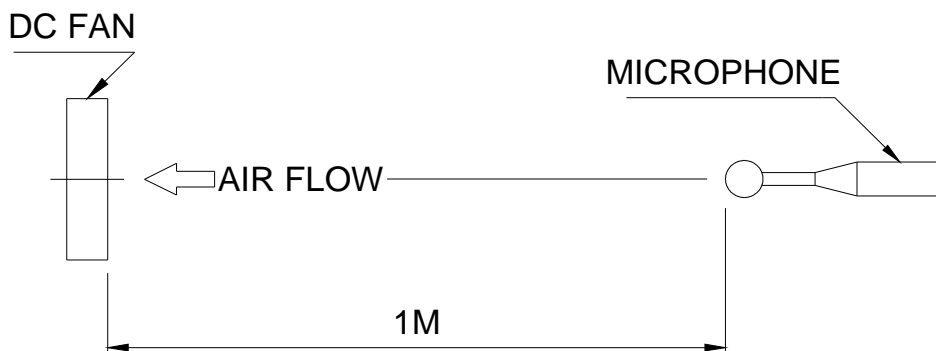

NOISE IS MEASURED AT RATED VOLTAGE IN FREE AIR IN ANECHOIC CHAMBER WITH B & K SOUND LEVEL METER WITH MICROPHONE AT A DISTANCE OF ONE METER FROM THE FAN INTAKE.

---

PART NO:

---

DELTA MODEL: PFB0948GHED6W

---

3. MECHANICAL:

- 3-1. DIMENSIONS----- SEE DIMENSIONS DRAWING
- 3-2. FRAME----- PLASTIC UL: 94V-0
- 3-3. IMPELLER----- PLASTIC UL: 94V-0
- 3-4. BEARING SYSTEM----- TWO BALL BEARINGS
- 3-5. WEIGHT----- 260 GRAMS(REF.)
- 3-6. SALT FOG TEST COMPLY----- GR-487
- 3-7. INGRESS PROTECTION RATING ----- IP56

4. ENVIRONMENTAL:

- 4-1. OPERATING TEMPERATURE----- -10 TO +70 DEGREE C
- 4-2. STORAGE TEMPERATURE----- -40 TO +75 DEGREE C
- 4-3. OPERATING HUMIDITY----- 5 TO 90 % RH
- 4-4. STORAGE HUMIDITY----- 5 TO 95 % RH

5. PROTECTION:

- 5-1. LOCKED ROTOR PROTECTION  
IMPEDANCE OF MOTOR WINDING PROTECTS MOTOR FROM FIRE IN  
96 HOURS OF LOCKED ROTOR CONDITION AT THE RATED VOLTAGE.
- 5-2. POLARITY PROTECTION  
BE CAPABLE OF WITHSTANDING IF REVERSE CONNECTION FOR  
POSITIVE AND NEGATIVE LEADS.

6. RE OZONE DEPLETING SUBSTANCES:

- 6-1. NO CONTAINING PBBs, PBBOs, CFCs, PBBEs, PBDPEs AND HCFCs.

7. PRODUCTION LOCATION

- 7-1. PRODUCTS WILL BE PRODUCED IN CHINA OR THAILAND.

PART NO:

DELTA MODEL: PFB0948GHED6W

8. P & Q CURVE:

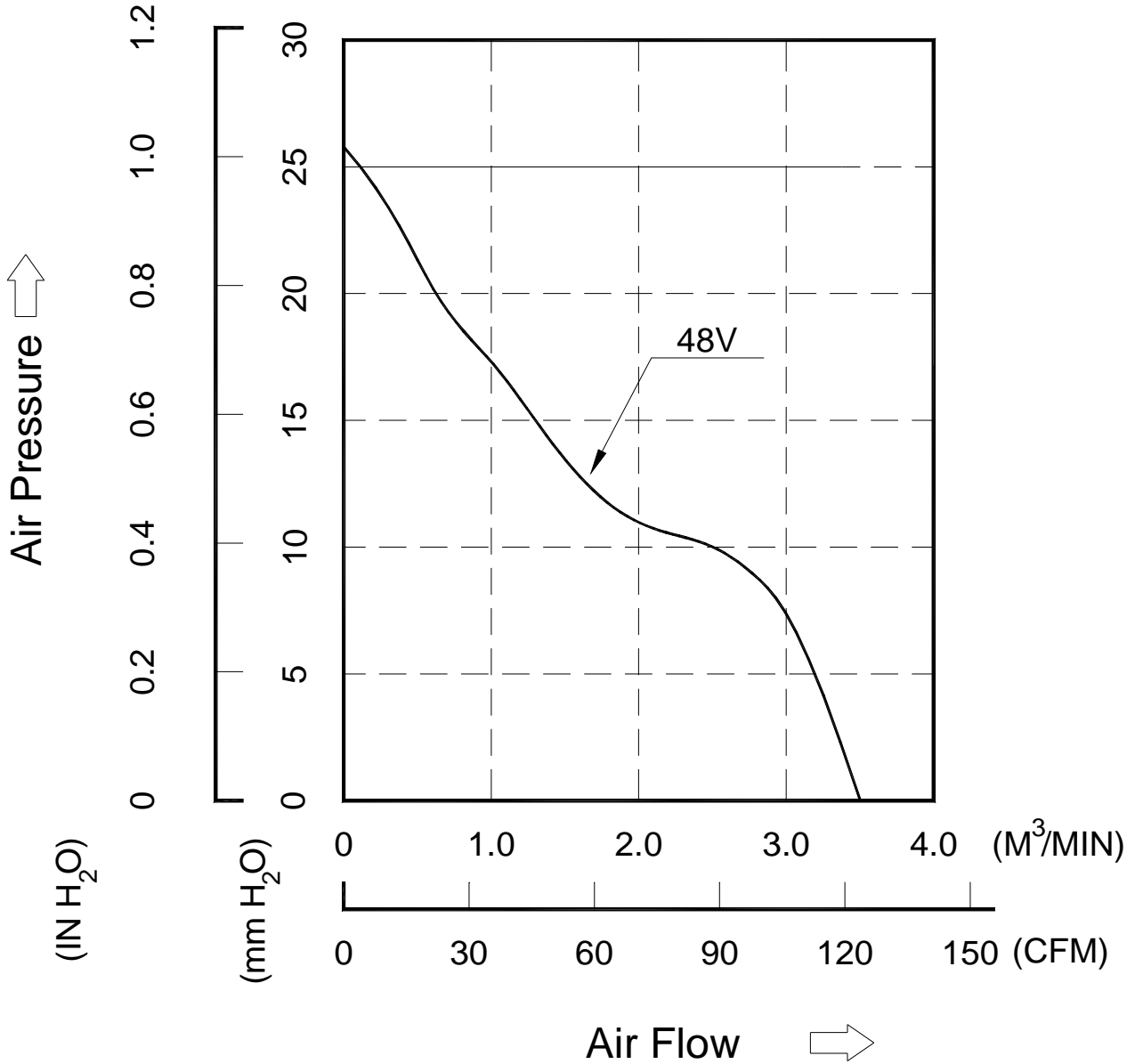

\*TEST CONDITION: INPUT VOLTAGE-----OPERATION VOLTAGE  
TEMPERATURE-----ROOM TEMPERATURE  
HUMIDITY-----65%RH

PART NO:

DELTA MODEL: PFB0948GHED6W

9. DIMENSION DRAWING:

LABEL:

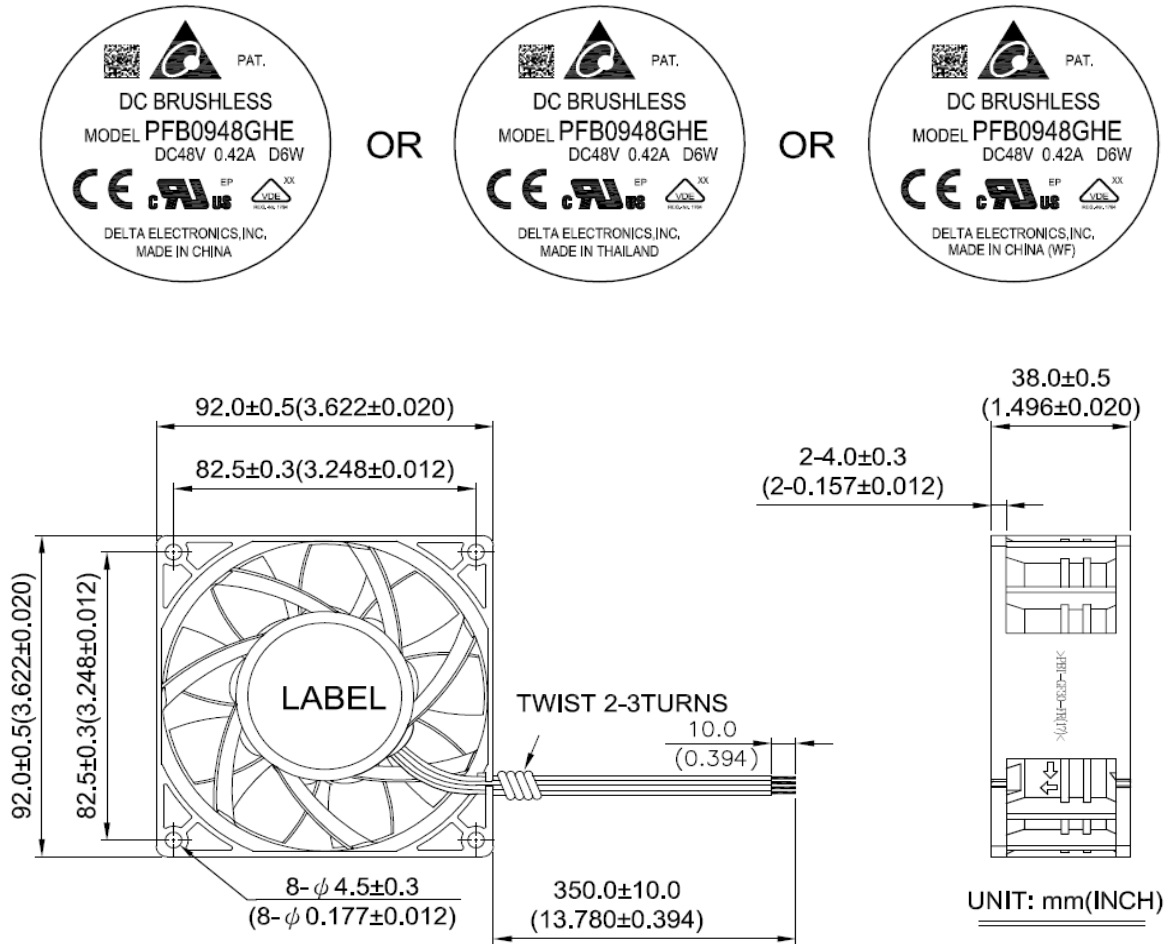

NOTES:

1. LEAD WIRE: UL1061 AWG#24  
RED WIRE ----- (+)  
BLACK WIRE ----- (-)  
BLUE WIRE ----- (R00)  
YELLOW WIRE ----- (PWM)
2. BARCODE SHOWS PRODUCTION INFORMATION  
(IT IS NOT AVAILABLE ON ENGINEERING SAMPLE.)
3. THIS PRODUCT IS ROHS COMPLIANT.



PART NO:

DELTA MODEL: PFB0948GHED6W

10. ROTATION DETECT (RD) SIGNAL:

10-1. OUTPUT CIRCUIT - OPEN COLLECTOR MODE:

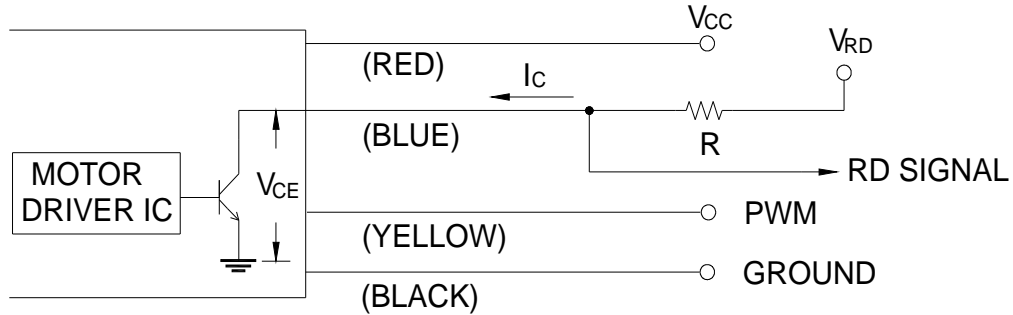

CAUTION: THE RD SIGNAL LEAD WIRE MUST BE KEPT AWAY FROM "+" LEAD WIRE & "-" LEAD WIRE.

10-2. SPECIFICATION:

$$V_{RD} = 60.0V \text{ MAX.}$$

$$I_c = 5mA \text{ MAX.}$$

$$V_{CE} = 0.5V \text{ MAX.}$$

$$R \geq V_{RD} / I_c$$

10-3. ROTATION DETECT WAVEFORM:

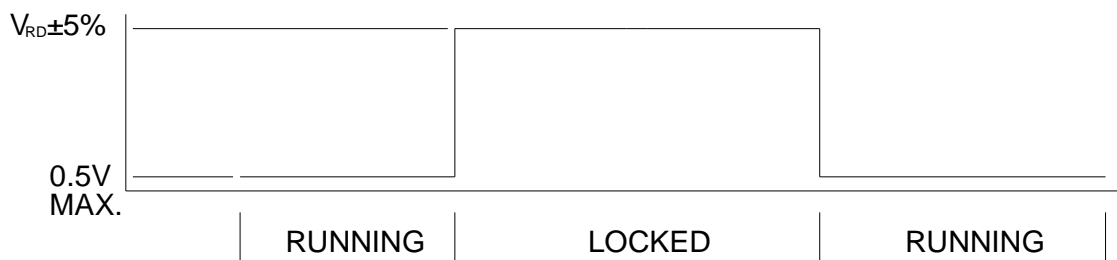

PART NO:

DELTA MODEL: PFB0948GHED6W

11. PWM CONTROL SIGNAL: (AT RATED VOLTAGE 48V ; 25 DEGREE C)  
SIGNAL VOLTAGE RANGE: 0~10 VDC

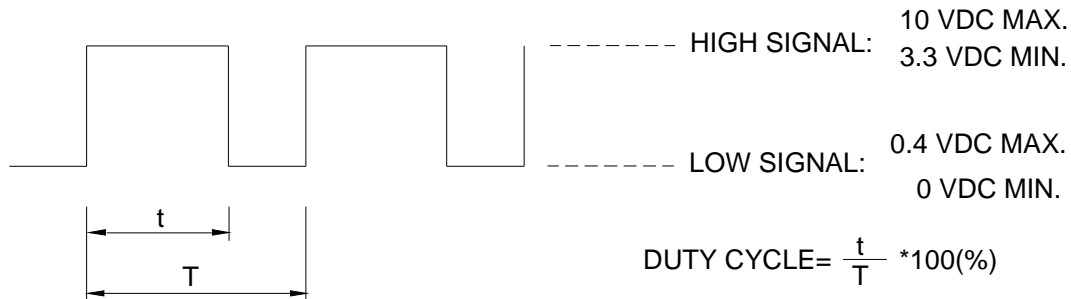

\*THE FREQUENCY FOR CONTROL SIGNAL OF THE FAN SHALL BE ABLE TO ACCEPT AT 15KHz~25KHz.

\*THE PREFERRED OPERATING POINT FOR THE FAN IS 20KHZ.

\*AT 48VDC & 100% DUTY CYCLE, THE ROTOR WILL SPIN AT MAXIMUM SPEED.

\*AT 48VDC & 0 % DUTY CYCLE, THE ROTOR WILL STOP.

\*WITH CONTROL SIGNAL LEAD DISCONNECTED, THE FAN WILL SPIN AT MAXIMUM SPEED.

\*AT 48VDC 20KHZ 20% DUTY CYCLE , THE FAN WILL BE ABLE TO START FROM A DEAD STOP .

12. SPEED VS PWM CONTROL SIGNAL: (AT RATED VOLTAGE 48V; 25 DEGREE C ; PWM SIGNAL WITH 5 VDC TTL OR CMOS LEVELS & 20KHZ)

DUTY CYCLE (%)	SPEED R.P.M.	CURRENT (A) TYP.
100	6000±10%	0.35
50	3400±10%	0.11
0	0	0.02

13. PWM CONTROL LEAD WIRE INPUT IMPEDANCE:

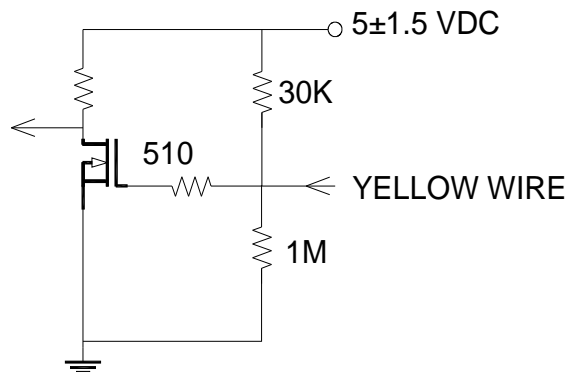

## Fan Characteristics Informations for Reference

\*\*\*\*\*

### INSTALLATION INSTRUCTION

#### SELF-TAPPING SCREW

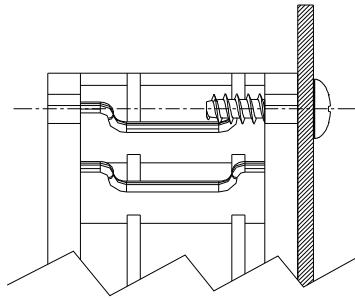

• FLANGE TYPE

MOUNTING HOLE DIAMETER	SCREW TYPE	SCREW SPEC.	RECOMMENDED MAX. TORQUE(kgf-cm)	
			FLANGE TYPE	RIB TYPE
$\phi$ 3.5	SELF-TAPPING	ST4.0x1.41	4.5	
$\phi$ 4.5	SELF-TAPPING	ST4.9x1.6	5.5	

#### MACHINE SCREW

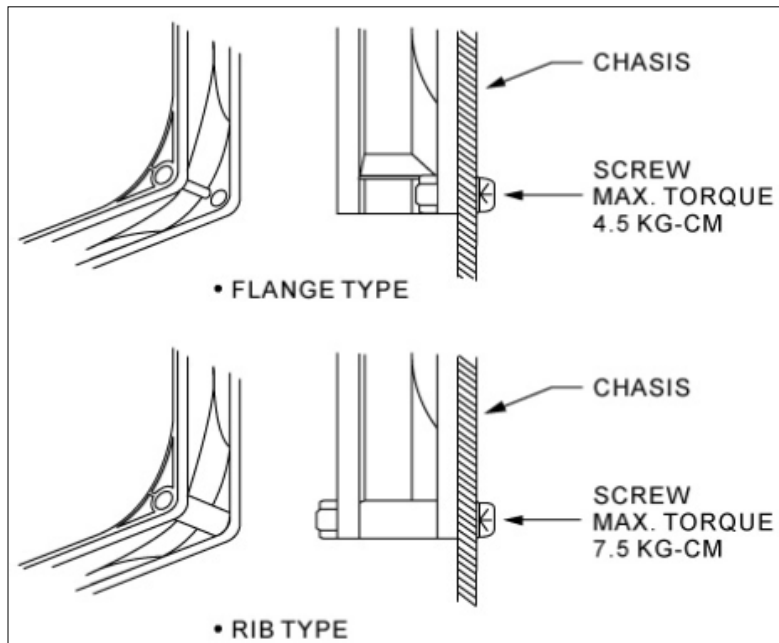



## *Application Notice*

1. Delta will not guarantee the performance of the products if the application condition falls outside the parameters set forth in the specification.
2. A written request should be submitted to Delta prior to approval if deviation from this specification is required.
3. Please exercise caution when handling fans. Damage may be caused when pressure is applied to the impeller, if the fans are handled by the lead wires, or if the fan was hard-dropped to the production floor.
4. Except as pertains to some special designs, there is no guarantee that the products will be free from any such safety problems or failures as caused by the introduction of powder, droplets of water or encroachment of insect into the hub.
5. The above-mentioned conditions are representative of some unique examples and viewed as the first point of reference prior to all other information.
6. It is very important to establish the correct polarity before connecting the fan to the power source. Positive (+) and Negative (-). Damage may be caused to the fans if connection is with reverse polarity, if there is no foolproof method to protect against such error specifically mentioned in this spec.
7. Delta fans without special protection are not suitable where any corrosive fluids are introduced to their environment.
8. Please ensure all fans are stored according to the storage temperature limits specified. Do not store fans in a high humidity environment. We highly recommend performance testing is conducted before shipping, if the fans have been stored over 6 months.
9. Not all fans are provided with the Lock Rotor Protection feature. If you impair the rotation of the impeller for the fans that do not have this function, the performance of those fans will lead to failure.
10. Please be cautious when mounting the fan. Incorrect mounting of fans may cause excess resonance, vibration and subsequent noise.
11. It is important to consider safety when testing the fans. A suitable fan guard should be fitted to the fan to guard against any potential for personal injury.
12. Except where specifically stated, all tests are carried out at room (ambient) temperature and relative humidity conditions of 25°C, 65% RH. The test value is only for fan performance itself.
13. Be certain to connect an "4.7µF or greater" capacitor to the fan externally when the application calls for using multiple fans in parallel, to avoid any unstable power.



Компания «ЭлектроПласт» предлагает заключение долгосрочных отношений при поставках импортных электронных компонентов на взаимовыгодных условиях!

Наши преимущества:

- Оперативные поставки широкого спектра электронных компонентов отечественного и импортного производства напрямую от производителей и с крупнейших мировых складов;
- Поставка более 17-ти миллионов наименований электронных компонентов;
- Поставка сложных, дефицитных, либо снятых с производства позиций;
- Оперативные сроки поставки под заказ (от 5 рабочих дней);
- Экспресс доставка в любую точку России;
- Техническая поддержка проекта, помощь в подборе аналогов, поставка прототипов;
- Система менеджмента качества сертифицирована по Международному стандарту ISO 9001;
- Лицензия ФСБ на осуществление работ с использованием сведений, составляющих государственную тайну;
- Поставка специализированных компонентов (Xilinx, Altera, Analog Devices, Intersil, Interpoint, Microsemi, Aeroflex, Peregrine, Syfer, Eurofarad, Texas Instrument, Miteq, Cobham, E2V, MA-COM, Hittite, Mini-Circuits, General Dynamics и др.);

Помимо этого, одним из направлений компании «ЭлектроПласт» является направление «Источники питания». Мы предлагаем Вам помощь Конструкторского отдела:

- Подбор оптимального решения, техническое обоснование при выборе компонента;
- Подбор аналогов;
- Консультации по применению компонента;
- Поставка образцов и прототипов;
- Техническая поддержка проекта;
- Защита от снятия компонента с производства.



#### Как с нами связаться

**Телефон:** 8 (812) 309 58 32 (многоканальный)

**Факс:** 8 (812) 320-02-42

**Электронная почта:** [org@eplast1.ru](mailto:org@eplast1.ru)

**Адрес:** 198099, г. Санкт-Петербург, ул. Калинина, дом 2, корпус 4, литера А.