

RK119 1 1 mm Size Metal Shaft Reflow Type

1.5mm-travel push-on switch achieved in a low-profile height of only 5mm

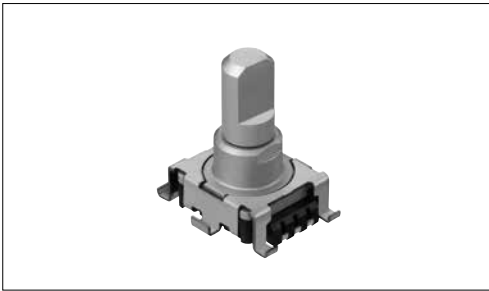

Typical Specifications

Items	Specifications
Total resistance tolerance	±20%
Maximum operating voltage	10V DC
Total rotational angle	300° ± 10°
Rotational torque	7.5±3.5mN·m
Operating life	15,000 cycles
Operating temperature range	-40°C to +85°C

Product Line

Number of resistor elements	Mounting direction	Shaft type	Length of the shaft L ₁ (mm)	Detent	Total resistance (kΩ)	Resistance taper	Switch travel (mm)	Minimum order unit (pcs.)		Products No.	Drawing No.
								Japan	Export		
Single-unit	Vertical type	Flat	15	Without	10	1B	Without	480	480	RK1191110001	1
							0.5			RK1191114001	2
							1.5			RK1191124001	3

Note

Other varieties are also available. Refer to "Other Specifications" (P.323).

Packing Specifications

Tray





Number of packages (pcs.)		Export package measurements (mm)
1 case /Japan	1 case /export packing	
480	480	300×240×270

Refer to P.323 for other specifications.
 Refer to P.323 for switch specifications.
 Refer to P.324 for ordering products not listed.
 Refer to P.343 for soldering conditions.

RK119 1 1 mm Size Metal Shaft Reflow Type

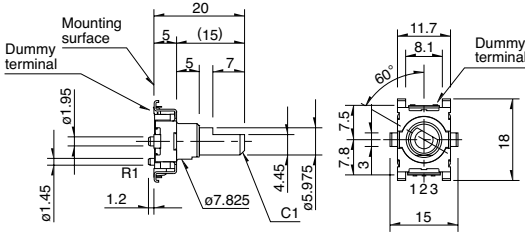
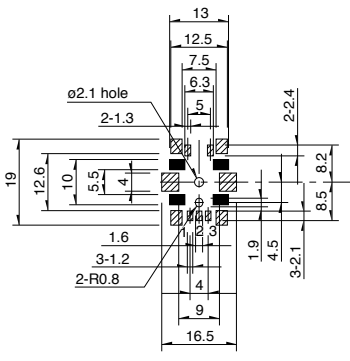
Dimensions

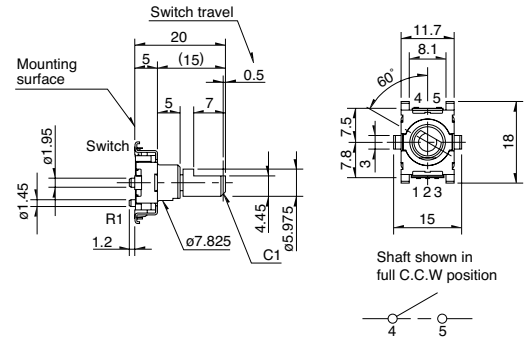
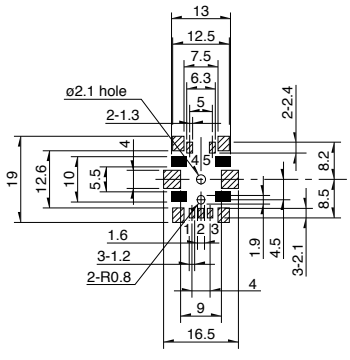
Unit:mm

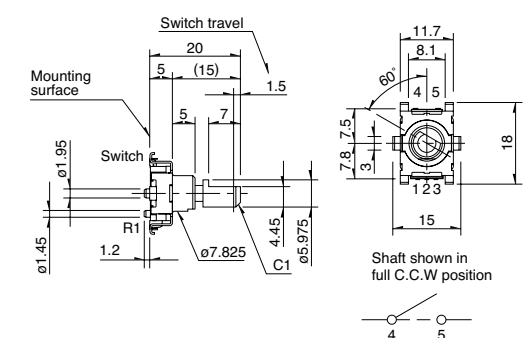
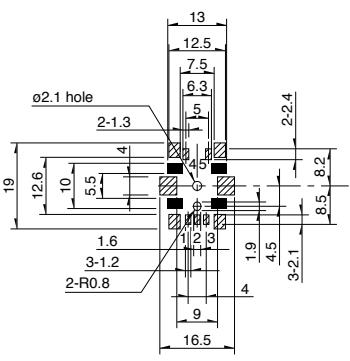
No.	Photo	Style	PC board mounting hole dimensions (Viewed from mounting side)
1		 <p>Shaft shown in full C.C.W position</p>	 <p>A slant line part: The solder land Black part: Do not solder and wiring for electrical contact</p>
2		 <p>Shaft shown in full C.C.W position</p>	 <p>A slant line part: The solder land Black part: Do not solder and wiring for electrical contact</p>
3		 <p>Shaft shown in full C.C.W position</p>	 <p>A slant line part: The solder land Black part: Do not solder and wiring for electrical contact</p>

1 1 mm Size Metal Shaft Reflow Type / Other Specifications

In addition to the products listed, we can accommodate the follow specifications.

■ Detent and Attached Switch

Varieties	Items	Attached switches travel	
		Detent	
Single-shaft, Single-unit		Without	0.5mm / 1.5mm

■ Dimensions of Shaft

Flat type

Unit:mm

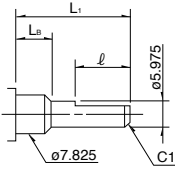

Detail dimensions (mm)

L ₁	※ L _B	l
(15)	5	7
(20)	5	10

Shaft shown in full CCW position.

Notes

- ※ L_B does not support M7 (with screws).
- Marked are specifications recommended by Alps Alpine.

1 1 mm Size Metal Shaft Reflow Type / Switch Specifications

Switch type	Momentary push switch	
Contact arrangement	Single pole and single throw (Push-on)	
Travel (mm)	0.5±0.3	1.5±0.5
Operating force	5±2N	4±2N
Operating life	20,000 times	
Electrical performance	Rating	0.1A 5V DC (0.1mA 5V DC min. ratings)
	Contact resistance	100mΩ max. for initial period, 200mΩ max. after operating life.
	Insulation resistance	100MΩ max. 250V DC
	Voltage proof	300V AC for 1 minute or 360V AC for 2 second

1 mm Size Metal Shaft Reflow Type / Ordering Products Not Listed

When ordering product varieties that are not listed, specify referring to the examples below.

■ Sample Part Number

R K 1 1 9 1 1 1 0 - **F 1 5** - **C 0** - **B 1 0 3**

Switch Specification

Code	Switch Specification
10	Without switch
14	With momentary push switch (0.5mm travel)
24	With momentary push switch (1.5mm travel)

Length of the shaft L₁ (mm)

Code	Length of the shaft
15	15
20	20

Detent

Code	Detent
C0	Without

Resistance taper

Code	Resistance taper
B	1B

B: For tone & general

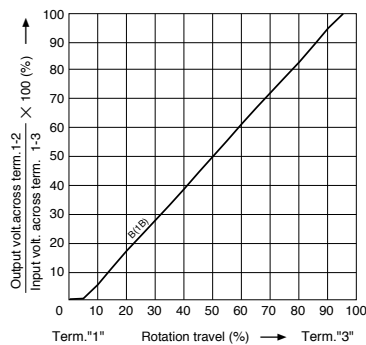

Total resistance

Code	Total resistance (kΩ)
103	10











Note

Marked are specifications recommended by Alps Alpine.

Rotary Potentiometers
 Slide Potentiometers
 Metal Shaft
 Insulated Shaft
 Knob Operating
 Through Shaft Type
 Ring Type

Metal Shaft Potentiometers

List of Varieties

Type	9mm size				11mm size
Series	RK09L		RK0971	RK0972	RK119
	Single-shaft			Dual-shaft	Single-shaft
Number of resistor elements	Single/dual			Dual	Single
Photo					
Terminal mounting	Horizontal	Vertical	Horizontal		Vertical
Fixing method of bushing	Screw				Guide
Operating temperature range	-10°C to +70°C		-20°C to +70°C -40°C to +85°C (Vehicle-compatible)		-40°C to +85°C
Operating life	15,000 cycles				
Available for automotive use	—	—	○	○	○
Life cycle (availability)					
Electrical performance	Total resistance (kΩ)	10, 20, 50, 100			10
	Resistance taper	15A, 1B, 3B, 15C			1B
	Rated Power	0.05W			
	Residual resistance	$R \leq 10k\Omega$ 20Ω max. $10k\Omega < R < 50k\Omega$ 30Ω max. $50k\Omega \leq R$ Nominal total resistance of 0.1% or less			$R \leq 10k\Omega$ 50Ω max.
	Maximum attenuation (Volume control)	$5k\Omega \leq R < 10k\Omega$ 70dB min. $10k\Omega \leq R < 50k\Omega$ 80dB min. $50k\Omega \leq R$ 90dB min.	$5k\Omega \leq R < 10k\Omega$ 70dB min. $10k\Omega \leq R < 50k\Omega$ 80dB min. $50k\Omega \leq R < 100k\Omega$ 90dB min. $100k\Omega \leq R$ 100dB min.		—
	Gang error applicable to Dual-unit parts for audio volume control purposes	-40dB to 0dB 3dB max.			—
	Insulation resistance	100MΩ min. 250V DC			
	Voltage proof	300V AC for 1minute			300V AC for 1 minute or 360V for 2s
	Center-taps	Without	Without / With		Without
Mechanical performance	Detent	Without, Center			Without
	Stopper strength	0.5N·m	0.5N·m (With push-lock mechanism: 0.4N·m)		0.5N·m
	Push-pull strength	80N max.	100N max.		
	Vibration	10 to 55 to 10Hz/min., the amplitude is 1.5mm for all the frequencies, in the 3 direction of X, Y and Z and for 2 hours respectively			
Shaft style	Flat type			Inner-shaft: flat type Outer-shaft: slotted type	Flat type
Terminal style	Insertion				Reflow
Attached switch	—	—	Rotary switch Push-on push-off switch Push-on switch Push-lock switch	—	Push-on switch
Page	306		310		321

Metal Shaft Potentiometers Soldering Conditions	343
Potentiometers Cautions	418
Potentiometers Measurement and Test Methods	420
Potentiometers Resistance Taper	422

Notes

- For the switch attached, the single-shaft or inner shaft of the dual-shaft type can be chosen.
- The operating temperature range for automotive applications can be raised upon request. Please contact us for details.
- Indicates applicability to some products in the series.

Reference for Manual Soldering

Series	Tip temperature	Soldering time	No. of solders
RK09L, RK097	350°C max.	3s max.	1 time
RK203	300°C max.	3s max.	1 time
RK119	350±10°C	3 ⁺¹ ₀ s	1 time
RK271	350°C max.	5s max.	1 time
RK501	350±10°C	5 ⁺¹ ₀ s	1 time
RK163	350°C max.	5s max.	1 time
RK168	Potentiometer terminal	300°C max.	3s max.
	Motor terminal	350°C max.	2s max.

Reference for Dip Soldering

Series	Preheating		Dip soldering		No. of solders
	Soldering surface temperature	Heating time	Soldering temperature	Soldering time	
RK09L, RK097, RK203	100°C max.	2 min. max.	260±5°C	5±1s	2 time max.
RK501	120±10°C	2 min. max.	260±5°C	5±1s	2 time

Example of Reflow Soldering Condition

Temperature profile

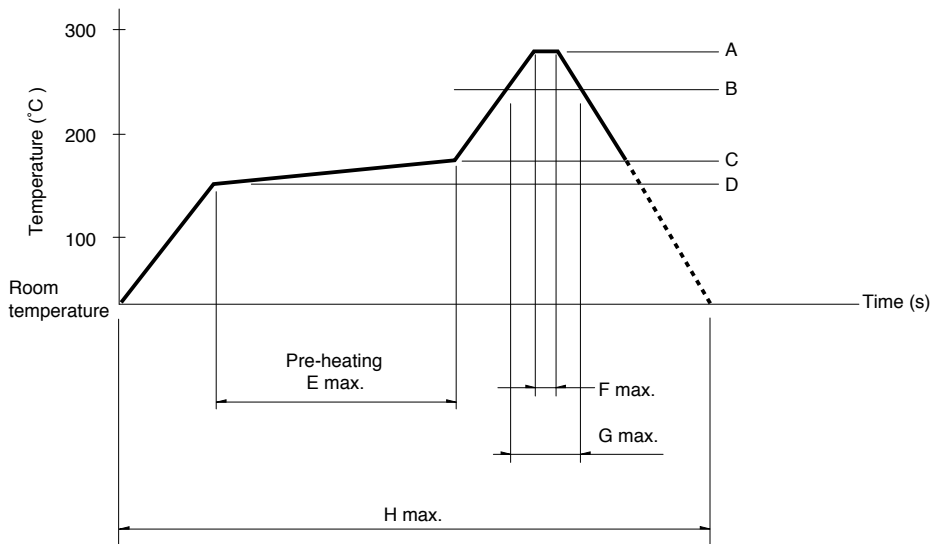

Series	A	B	C	D	E	F	G	H	No. of reflows
RK119	260°C	230°C	180°C	150°C	2 min.	3s	40s	4 min.	2 time max.

Notes

1. When using an infrared reflow oven, solder may sometimes not be applied. Be sure to use a hot air reflow oven or at type that uses infrared rays in combination with hot air.
2. The temperatures given above are the maximum temperatures at the terminals of the potentiometer when employing a hot air reflow method. The temperature of the PC board and the surface temperature of the potentiometer may vary greatly depending on the PC board material, its size and thickness. Ensure that the surface temperature of the potentiometer does not rise to 250°C or greater.
3. Conditions vary to some extent depending on the type of reflow bath used. Be sure to give due consideration to this prior to use.



Компания «ЭлектроПласт» предлагает заключение долгосрочных отношений при поставках импортных электронных компонентов на взаимовыгодных условиях!

Наши преимущества:

- Оперативные поставки широкого спектра электронных компонентов отечественного и импортного производства напрямую от производителей и с крупнейших мировых складов;
- Поставка более 17-ти миллионов наименований электронных компонентов;
- Поставка сложных, дефицитных, либо снятых с производства позиций;
- Оперативные сроки поставки под заказ (от 5 рабочих дней);
- Экспресс доставка в любую точку России;
- Техническая поддержка проекта, помощь в подборе аналогов, поставка прототипов;
- Система менеджмента качества сертифицирована по Международному стандарту ISO 9001;
- Лицензия ФСБ на осуществление работ с использованием сведений, составляющих государственную тайну;
- Поставка специализированных компонентов (Xilinx, Altera, Analog Devices, Intersil, Interpoint, Microsemi, Aeroflex, Peregrine, Syfer, Eurofarad, Texas Instrument, Miteq, Cobham, E2V, MA-COM, Hittite, Mini-Circuits, General Dynamics и др.);

Помимо этого, одним из направлений компании «ЭлектроПласт» является направление «Источники питания». Мы предлагаем Вам помощь Конструкторского отдела:

- Подбор оптимального решения, техническое обоснование при выборе компонента;
- Подбор аналогов;
- Консультации по применению компонента;
- Поставка образцов и прототипов;
- Техническая поддержка проекта;
- Защита от снятия компонента с производства.



Как с нами связаться

Телефон: 8 (812) 309 58 32 (многоканальный)

Факс: 8 (812) 320-02-42

Электронная почта: org@eplast1.ru

Адрес: 198099, г. Санкт-Петербург, ул. Калинина, дом 2, корпус 4, литера А.