



BOURNS®

Features

- Patented (MSP®) Multi-Stage Protection
- Balanced TRIGARD®
- Self-resetting low resistance sneak current protection with Bourns® PPTC resistors
- Patented Switch-Grade Fail-Short device
- Quick response and high energy handling
- UL Listing per UL497 (File E53117)
- Sealed option for harsh environments
- Meets test requirements of GR 974, GR 1361, SBC SR 5165 and RUS PE-80
- Telcordia Analysis report DA-1547
- Ideal for high-speed networks in high-exposure environments
- Solid brass, gold-plated pins
- Test point access option

2430 Series 5-Pin Surge Protector

Bourns® 5-pin Model 2430 is a new generation of Bourns® telecommunications protectors for superior performance and long life. The 2430 series protector provide highly reliable overvoltage and self-resetting sneak current protection for copper pair voice-band and high speed data circuits. The Bourns® MSP® device combines the advantages of gas tube and solid state protection, while integrating three advanced technologies: a proprietary high-efficiency gas discharge tube, precision matched metal oxide varistors and a patented Switch-Grade Fail-Short mechanism. The unique Switch-Grade Fail-Short mechanism ensures superior thermal protection with fast acting, highly reliable response to thermal overload conditions. This combined technology provides lower capacitance, higher reliability and longer life than competitive hybrid technologies. Bourns® Multifuse® PPTCs are used for sneak current protection providing reliable and self-resetting performance with less than four ohms of resistance.

Bourns® 2430 protectors can be used universally for broadband voice and data circuits including ADSL, ADSL2+, VDSL, VDSL2 and high-speed Ethernet. The 2430 series is an innovative, superior choice for 5 pin protection of copper pair circuits.

Characteristics

Test methods per UL 497, CSA C22.2, Telcordia GR 974, 1361 and SBC SR 5165.

DC Breakdown	300-400 V
AC Breakdown @ 60 Hz	300-400 V
Impulse Breakdown	
100 V/ μ s	600 V
1000 V/ μ s	650 V
Insulation Resistance @ 100 Vdc	> 1 G Ω
Insertion Loss @ 100 MHz	< 1.0 dB ¹
Return Loss @ 100 MHz	> 14 dB ¹
Capacitance Tip to Ring @ 1 MHz	12 pF typical
Capacitance Tip or Ring to Ground @ 1 MHz	23 pF typical
Impulse Reset ⁵	
52 V, 260 mA	< 10 ms ²
135 V, 200 mA	< 10 ms ²
150 V, 200 mA	< 150 ms
Impulse Life Characteristics (Tip and Ring to Ground Simultaneously)	
10 A to 100 A, 10/1000 μ s	> 3000 operations ²
300 A, 10/1000 μ s	> 1000 operations ²
500 A, 10/1000 μ s	> 1000 operations ⁴
2,000 A, 10/250 μ s	> 100 operations ²
5,000 A, 20/100 μ s	> 10 operations ²
20,000 A, 8/20 μ s	> 10 operations ⁴
AC Life Characteristics (Tip and Ring to Ground Simultaneously)	
0.5 A rms continuous	> 30 seconds
1 A rms, 1 second, 600 ft. cable	> 60 operations
1 A rms, 1 second, 1 mile cable	> 60 operations
10 A rms, 1 second	> 5 operations
65 A rms, 11 cycles	> 1 operation ³
120 A rms, 0.1 second	1 operation
High Current Capability and Thermal Operation (T/R to Ground)	> 30 Arms, simultaneously
Storage and Operating Temperature	-55 to +85 °C
Sneak Current Characteristics	
Resistance (No Heat Coil Inductance)	< 4 ohms
Transition Current @ -40 °C (800 mA), +20 °C (540 mA), +65 °C (300 mA)	< 210 seconds
Rated Current @ -40 °C (100 mA), +20 °C (100 mA), +65 °C (100 mA)	> 3 hours
Impulse Life 10 x 1000 μ s @ -40 °C, +20 °C, +65 °C	25 A ELTGS

Telcordia analyzed for controlled (non-sealed) and uncontrolled high exposure (sealed) environments per GR 974 and SBC SR 5165. Please refer to Telcordia Analysis Report DA-1547 Volumes 1 and 2.

Notes:

¹ Tested according to Category 5 requirements.

² Exceeds Telcordia (Bellcore) GR 1361.

³ Surpasses Telcordia GR 974.

⁴ RUS (REA) PE-80.

⁵ Network applied.

Line to Line voltage is approximately 1.8 to 2 times the stated Line to Ground breakdown voltage.

2430 Series 5-Pin Surge Protector

BOURNS®

Product Dimensions

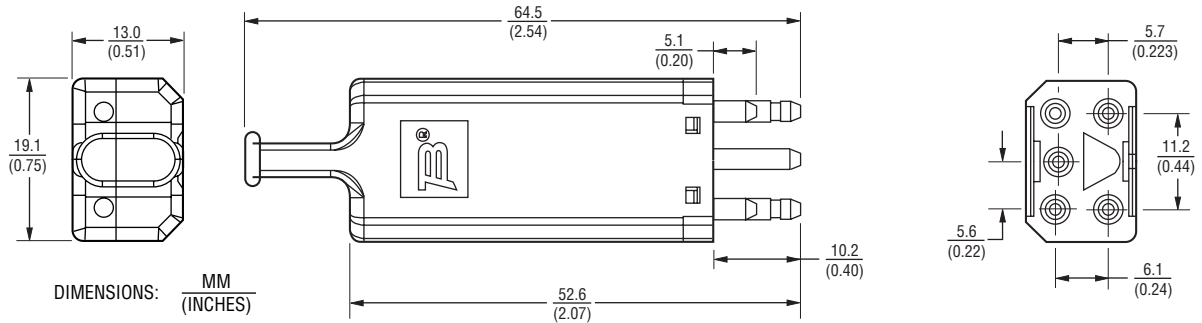

Schematic

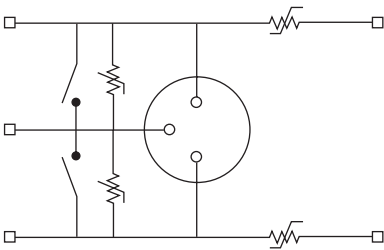

How To Order

2430 - 4 xx - x - xx - xx

Model Number Designator _____

Overcurrent Protection _____

Housing Color _____

- 1 = Black
- 3 = Red
- 6 = Blue
- 7 = Violet
- 9 = Orange
- 10 = Yellow

Pin Plating _____

- G = Gold Plated
- N = Tin Plated (Ground pin is tin plated on all models)

MOV Balance _____

- Blank = Standard MSP®
- BC = Balanced Capacitance*

Housing Options _____

- S = Sealed
- T = Test Points
- ST = Sealed and Test Points

Examples:

2430-41-G-T = Black housing, gold-plated pins, standard MSP®, 4 ohm, test points

2430-43-N-BC = Red housing, tin-plated pins, balanced capacitance MSP®, 4 ohm

*For use on DSL Systems that require balanced capacitance of ≤ 1 pF.

BOURNS®

Asia-Pacific: Tel: +886-2 2562-4117 • Fax: +886-2 2562-4116

Europe: Tel: +41-41 768 5555 • Fax: +41-41 768 5510

The Americas: Tel: +1-951 781-5500 • Fax: +1-951 781-5700

www.bourns.com

REV. I 02/12

Specifications are subject to change without notice.

Customers should verify actual device performance in their specific applications.



Компания «ЭлектроПласт» предлагает заключение долгосрочных отношений при поставках импортных электронных компонентов на взаимовыгодных условиях!

Наши преимущества:

- Оперативные поставки широкого спектра электронных компонентов отечественного и импортного производства напрямую от производителей и с крупнейших мировых складов;
- Поставка более 17-ти миллионов наименований электронных компонентов;
- Поставка сложных, дефицитных, либо снятых с производства позиций;
- Оперативные сроки поставки под заказ (от 5 рабочих дней);
- Экспресс доставка в любую точку России;
- Техническая поддержка проекта, помощь в подборе аналогов, поставка прототипов;
- Система менеджмента качества сертифицирована по Международному стандарту ISO 9001;
- Лицензия ФСБ на осуществление работ с использованием сведений, составляющих государственную тайну;
- Поставка специализированных компонентов (Xilinx, Altera, Analog Devices, Intersil, Interpoint, Microsemi, Aeroflex, Peregrine, Syfer, Eurofarad, Texas Instrument, Miteq, Cobham, E2V, MA-COM, Hittite, Mini-Circuits, General Dynamics и др.);

Помимо этого, одним из направлений компании «ЭлектроПласт» является направление «Источники питания». Мы предлагаем Вам помощь Конструкторского отдела:

- Подбор оптимального решения, техническое обоснование при выборе компонента;
- Подбор аналогов;
- Консультации по применению компонента;
- Поставка образцов и прототипов;
- Техническая поддержка проекта;
- Защита от снятия компонента с производства.



Как с нами связаться

Телефон: 8 (812) 309 58 32 (многоканальный)

Факс: 8 (812) 320-02-42

Электронная почта: org@eplast1.ru

Адрес: 198099, г. Санкт-Петербург, ул. Калинина, дом 2, корпус 4, литера А.