

Quad Channel Ultrasound Echo Multiplexer with T/R Switch

Features

- ▶ Quad channel analog echo signal MUX switches
- ▶ $\pm 130V$ 20ns T/R switch built-in for each channel
- ▶ 17Ω total on-resistance for low insertion loss
- ▶ $0.8nV/rt.Hz$ low RF input noise at 5MHz
- ▶ DC to 100MHz small signal bandwidth
- ▶ $-65dB$ off-Isolation and $-55dB$ crosstalk
- ▶ Single +5V power supply
- ▶ Low power consumption
- ▶ 20MHz serial interface 3.3V CMOS logic
- ▶ $-55dB$ HD2 very low echo signal distortions

Applications

- ▶ Medical imaging ultrasound beamforming receiver
- ▶ Software programmable echo multiplex switching
- ▶ High resolution phase array ultrasound NDT
- ▶ Ultrasonic phase array receiver focusing
- ▶ Array PZT transducer echo phase processing

General Description

The MD0200 is a multi-channel, low voltage, analog multiplex switch with a high voltage T/R switch and diode voltage limiter circuit. It is designed for medical ultrasound image system receive beamforming applications. It also can be used in NDT and other ultrasound applications.

The MD0200 circuit consists of a low voltage CMOS analog switch and digital logic serial interface circuits. This analog switch not only has very low insertion loss and noise and wide frequency response, it also has high isolation and low channel to channel crosstalk. The inputs of the analog switch are connected to the output of the two terminal type of ultrasound T/R switch, and two back-to-back diode voltage limiter circuits.

The shift-register and latch-register serial interface has allowed the IC maximum flexibility to connect a large number of channels together to form the echo multiplexing dynamic-focusing circuit for ultrasound image receive beamforming.

Block Diagram

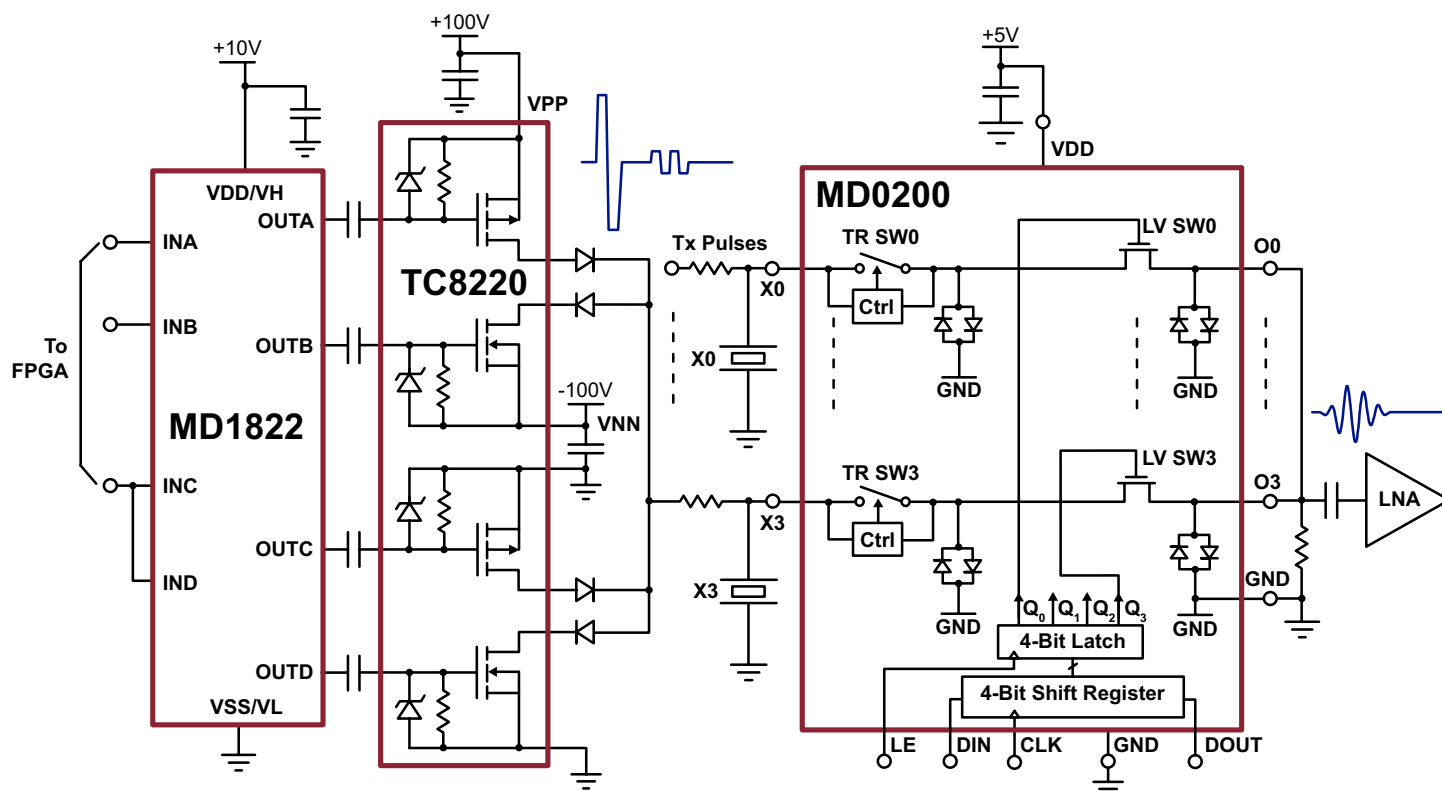

Ordering Information

Part Number	Package Options	Packing
MD0200K6-G	18-Lead DFN (5x5)	490/Tray
MD0200K6-G M932	18-Lead DFN (5x5)	2500/Reel

-G denotes a lead (Pb)-free / RoHS compliant package



ESD Sensitive Device

Pin Configuration

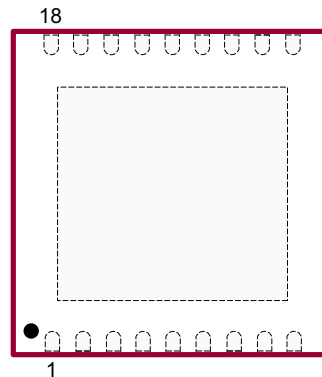

18-Lead DFN
(top view)

Absolute Maximum Ratings¹

Parameter	Value
GND reference voltage	0V
X0~X3 input pins to GND voltage	0 to ±140V
V _{DD} positive supply	-0.5V to +6.5V
All logic input pins	-0.5V to +6.5V
Maximum junction temperature	+125°C
Storage temperature range	-65°C to 150°C

Note:

1. Absolute Maximum Ratings are those values beyond which damage to the device may occur. Functional operation under these conditions is not implied. Continuous operation of the device at the absolute rating level may affect device reliability. All voltages are referenced to device ground.

Product Marking

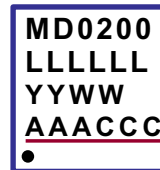

L = Lot Number
YY = Last Digit of Year Sealed
WW = Code for Week Sealed
A = Assembler ID
C = Country of Origin
— = "Green" Packaging

18-Lead DFN

Package may or may not include the following marks: Si or

Typical Thermal Resistance

Package	θ_{ja}
18-Lead DFN	30°C/W

Operating Supply Voltages (Over operating conditions unless otherwise specified, V_{DD} = +5V, T_j = 25°C)

Sym	Parameter	Min	Typ	Max	Unit	Conditions
V _{SIG}	Signal input range (p-p)	-	±400	-	mV	---
V _{DD}	Positive voltage power supply	4.75	5.00	5.25	V	T _A = 0 to 70°C
R _{ON}	Total switch ON-resistance X ₀₋₃ to O ₀₋₃	-	17.5	-	Ω	I _X = ±5.0mA, V _{X0-3} = ±300mV
ΔR _{ON}	Ch to Ch R _{ON} difference	-	±5	-	%	---
V _F	Diode forward voltage	-	0.8	1.0	V	1mA
		-	1.25	1.50		100mA
I _{FM}	Diode forward continuous current	-	100	-	mA	---
I _{DDQ}	V _{DD} supply current 0MHz	-	0.1	0.2	mA	f _{CLK} = 0Hz
I _{DD20}	V _{DD} supply current 20MHz	-	8.0	10	mA	f _{CLK} = 20Hz
HD2	Second harmonic distortion	-	-55	-	dB	5MHz sine wave, ±300mV p-p input

T/R Switch Characteristics (Over operating conditions unless otherwise specified, $V_{DD} = +5V$, $T_j = 25^\circ C$)

Sym	Parameter	Min	Typ	Max	Unit	Conditions
V_X	Max X_{0-3} to GND input voltage	± 130	-	-	V	$I_X = \pm 500\mu A$
R_{TRSW}	Switch ON-resistance of T/R SWX ₀₋₃ to O ₀₋₃	-	15	-	Ω	$I_X = \pm 5.0mA$, $V_{X0-3} = \pm 300mV$
V_{TRIP}	VX ₀₋₃ trip point to turn off	-	± 1.0	± 2.0	V	---
V_{OFF}	T/R switch turn off voltage	-	± 2.0	-	V	$I_{A-B} = \pm 1.0mA$
I_{PEAK}	Peak T/R switch current	-	± 60	-	mA	---
T_{OFF}	Turn-OFF time	-	-	20	ns	---
T_{ON}	Turn-ON time	-	-	20	ns	---
$C_{SW(ON)}$	Switch ON-capacitance	-	15	-	pF	T/R SW = ON
$C_{SW(OFF)}$	Switch OFF-capacitance	-	9.0	-	pF	$V_{(X0-3)} = \pm 25V$
BW	Small signal bandwidth	-	100	-	MHz	$R_{LOAD} = 50\Omega$

Clock and Logic I/O Characteristics (Over operating conditions unless otherwise specified, $V_{DD} = +5V$, $T_j = 25^\circ C$)

V_{IH}	Input logic high voltage	2.5	3.3	5.0	V	Design for 3.3V Logic
V_{IL}	Input logic low voltage	0	-	0.6	V	
I_{IH}	Input logic high current	-	-	1.0	μA	---
I_{IL}	Input logic low current	-1.0	-	-	μA	---
C_{IN}	Input capacitance	-	10	12	pF	---
I_{OH}	Output logic high current	-	-	-2.0	mA	---
I_{OL}	Output logic low current	-	-	2.0	mA	---
V_{OH}	Output logic high voltage	4.5	-	-	V	$I_{OH} = -2.0mA$
V_{OL}	Output logic low voltage	-	-	0.35	V	$I_{OL} = -2.0mA$

AC Electrical Characteristics (Over operating conditions unless otherwise specified, $V_{DD} = +5V$, $T_j = 25^\circ C$)

Q_C	LV SW charge injection	-	3.0	7.0	pC	$V_{(X0-3)} = 0V$, O3~1 to GND 1nF load
BW	Small signal bandwidth	-	100	-	MHz	$R_{LOAD} = 50\Omega$
K_O	OFF-Isolation	-	-60	-	dB	At 10MHz, $R_{LOAD} = 50\Omega$, $\pm 300mVp-p$
K_{CR}	On-channel crosstalk	-	-55	-	dB	
$C_{(ON)}$	On-capacitance output to GND	-	42	45	pF	From O0~O3 to GND
$C_{(OFF)}$	OFF-capacitance output to GND	-	22	25	pF	---
f_{CLK}	Clock frequency	20	25	-	MHz	---
t_{SD}	Setup time before \overline{LE} rises	10	-	-	ns	---
t_H	Data hold time	10	-	-	ns	---
t_r/t_f	CLK rise or fall time	-	-	5.0	ns	---

AC Electrical Characteristics (cont.) (Over operating conditions unless otherwise specified, $V_{DD} = +5V$, $T_j = 25^\circ C$)

Sym	Parameter	Min	Typ	Max	Unit	Conditions
t_{WLE}	Time width of \overline{LE}	10	-		ns	---
t_{SU}	Data setup time	10	-		ns	---
t_{DO}	CLK delay time to data out	-	-		ns	---
dv/dt	Maximum V_x slew rate	-	-		V/ns	---
t_{ON}	ON time delay	-	3.0	5.0	μs	From CLK rise 50% to the switch full on or off time, at $\overline{LE} = 0$
t_{OFF}	OFF time delay	-	3.0	5.0	μs	
V_{SPK}	Spike of LV SW turning ON	-	5.0	10	mV	50 Ω on O0~3 to GND 1k Ω on X0~3 to GND
	Spike of LV SW turning OFF	-	5.0	10		

Logic Timing Waveforms

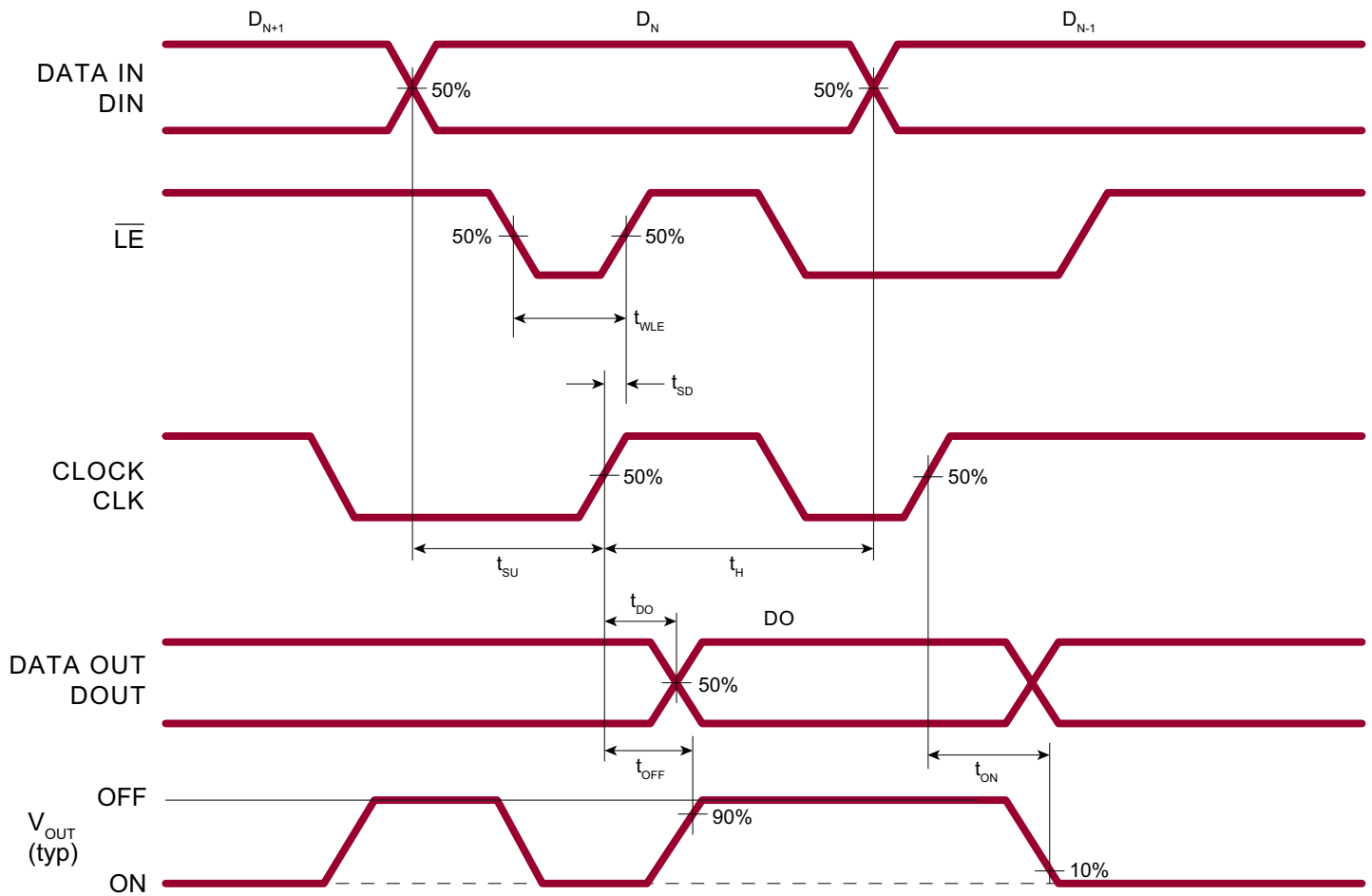

T/R Switch Typical I-V Curve

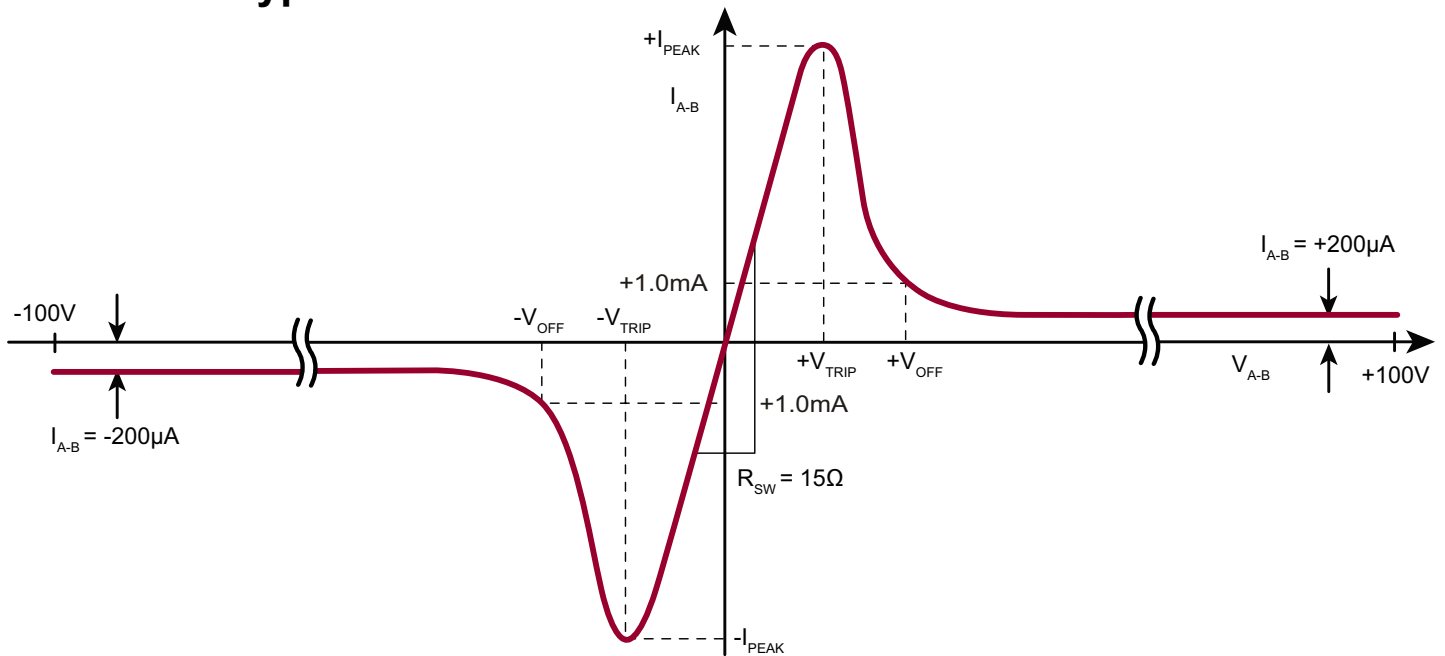

Pin Description

Pin	Name	Description
1	O0	Low voltage analog switch channel 0 output
2	O1	Low voltage analog switch channel 1 output
3	DIN	Serial Data Input
4	CLK	Shift register clock input
5	VDD	Positive voltage power supply +5V
6	\overline{LE}	Latch-Enable input - the switch status latched at the rising edge of \overline{LE} . When \overline{LE} is low the shift registers data flow through the latch
7	DOUT	Serial Data Output
8	O2	Low voltage analog switch channel 2 output
9	O3	Low voltage analog switch channel 3 output
10	NC	No internal connection
11	X3	T/R switch channel 3 high voltage input
12	NC	No internal connection
13	X2	T/R switch channel 2 high voltage input
14	NC	No internal connection
15	X1	T/R switch channel 1 high voltage input
16	NC	No internal connection
17	X0	T/R switch channel 0 high voltage input
18	NC	No internal connection
DAP	GND	The bottom thermal pad of DFN-18, Ground (0V)

Note: DAP must be connected to the ground on the PCB.

18-Lead DFN Package Outline (K6)

5.00x5.00mm body, 1.00mm height (max), 0.50mm pitch

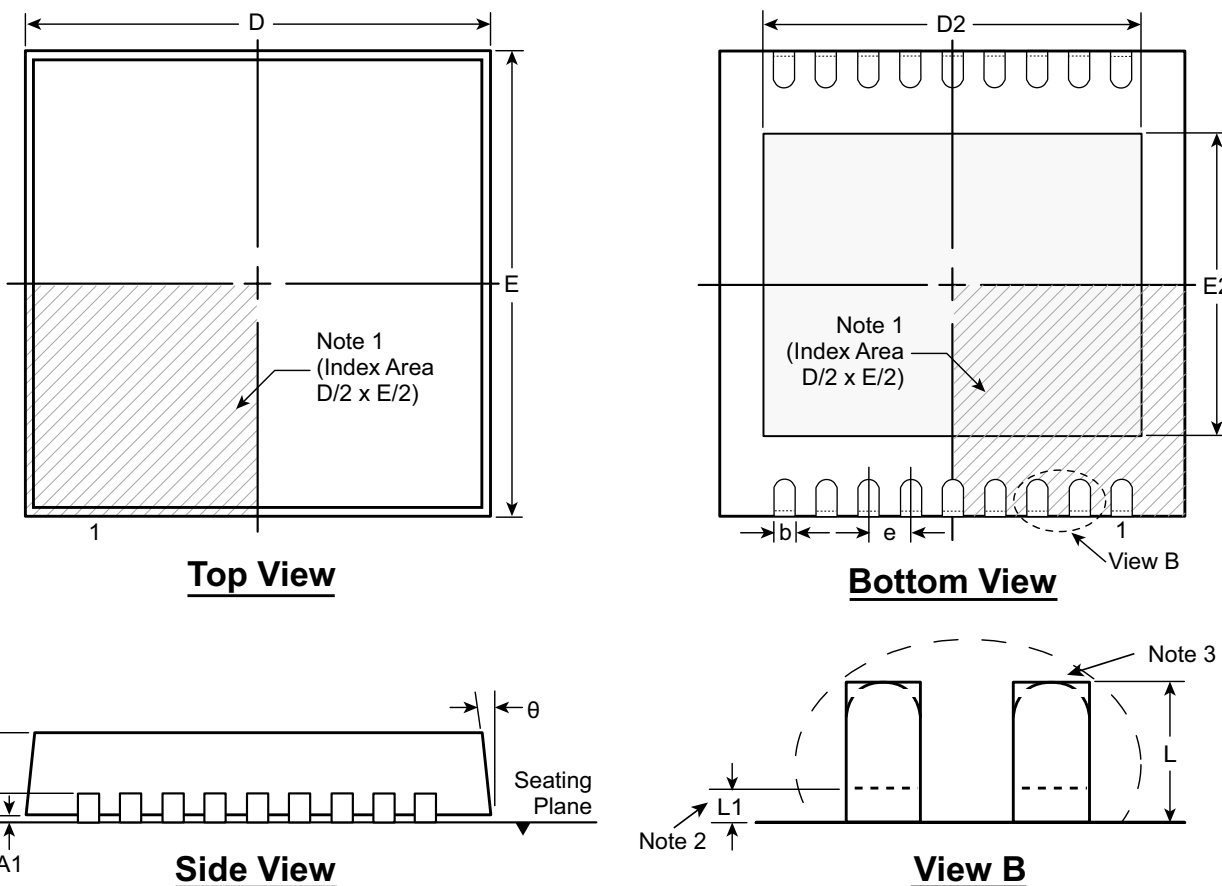

Notes:

1. A Pin 1 identifier must be located in the index area indicated. The Pin 1 identifier can be: a molded mark/identifier; an embedded metal marker; or a printed indicator.
2. Depending on the method of manufacturing, a maximum of 0.15mm pullback (L1) may be present.
3. The inner tip of the lead may be either rounded or square.

Symbol		A	A1	A3	b	D	D2	E	E2	e	L	L1	θ
Dimension (mm)	MIN	0.80	0.00	0.20 REF	0.18	4.85*	4.20 [†]	4.85*	3.50 [†]	0.50 BSC	0.30 [†]	0.00*	0°
	NOM	0.90	0.02		0.25	5.00	4.35 [†]	5.00	3.65 [†]		0.40 [†]	-	-
	MAX	1.00	0.05		0.30	5.15*	4.45 [†]	5.15*	3.75 [†]		0.50 [†]	0.15	14°

JEDEC Registration MO-229, Variation VJJD-2, Issue C, Aug 2003.

* This dimension is not specified in the JEDEC drawing.

† This dimension differs from the JEDEC drawing.

Drawings not to scale.

Supertex Doc. #: DSPD-18DFNK65X5P050, Version A013111.

(The package drawing(s) in this data sheet may not reflect the most current specifications. For the latest package outline information go to <http://www.supertex.com/packaging.html>.)

Supertex inc. does not recommend the use of its products in life support applications, and will not knowingly sell them for use in such applications unless it receives an adequate "product liability indemnification insurance agreement." **Supertex inc.** does not assume responsibility for use of devices described, and limits its liability to the replacement of the devices determined defective due to workmanship. No responsibility is assumed for possible omissions and inaccuracies. Circuitry and specifications are subject to change without notice. For the latest product specifications refer to the **Supertex inc.** (website: <http://www.supertex.com>)



Компания «ЭлектроПласт» предлагает заключение долгосрочных отношений при поставках импортных электронных компонентов на взаимовыгодных условиях!

Наши преимущества:

- Оперативные поставки широкого спектра электронных компонентов отечественного и импортного производства напрямую от производителей и с крупнейших мировых складов;
- Поставка более 17-ти миллионов наименований электронных компонентов;
- Поставка сложных, дефицитных, либо снятых с производства позиций;
- Оперативные сроки поставки под заказ (от 5 рабочих дней);
- Экспресс доставка в любую точку России;
- Техническая поддержка проекта, помощь в подборе аналогов, поставка прототипов;
- Система менеджмента качества сертифицирована по Международному стандарту ISO 9001;
- Лицензия ФСБ на осуществление работ с использованием сведений, составляющих государственную тайну;
- Поставка специализированных компонентов (Xilinx, Altera, Analog Devices, Intersil, Interpoint, Microsemi, Aeroflex, Peregrine, Syfer, Eurofarad, Texas Instrument, Miteq, Cobham, E2V, MA-COM, Hittite, Mini-Circuits, General Dynamics и др.);

Помимо этого, одним из направлений компании «ЭлектроПласт» является направление «Источники питания». Мы предлагаем Вам помощь Конструкторского отдела:

- Подбор оптимального решения, техническое обоснование при выборе компонента;
- Подбор аналогов;
- Консультации по применению компонента;
- Поставка образцов и прототипов;
- Техническая поддержка проекта;
- Защита от снятия компонента с производства.



Как с нами связаться

Телефон: 8 (812) 309 58 32 (многоканальный)

Факс: 8 (812) 320-02-42

Электронная почта: org@eplast1.ru

Адрес: 198099, г. Санкт-Петербург, ул. Калинина, дом 2, корпус 4, литера А.